



PSM3000

Operator's Manual



Phone (800) 464-5030

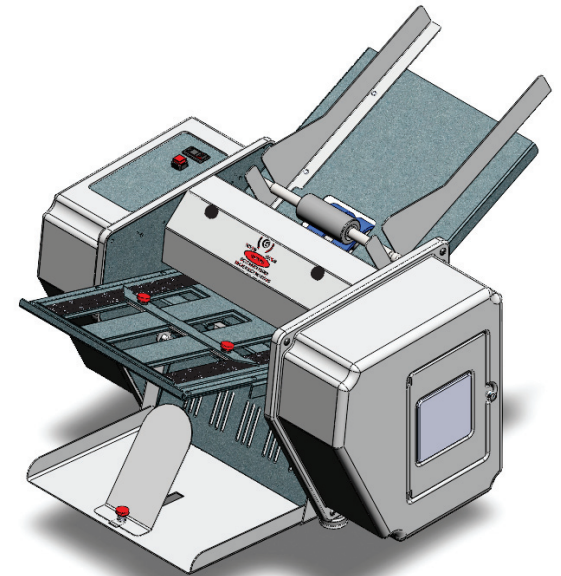

Paper Feed Problems

Double Feeds

If you're having problems feeding two forms at a time occasionally:

1. Turn the **Feed Gauge Adjustment Screw** [see Figure 8] ¼ turn counter-clockwise.
2. Try running the forms again.
3. If the problem persists:
 - a. Try another ¼ turn on the **Feed Gauge Adjustment Screw**.
 - b. Try reducing the size of the paper stack on the **Feed Table**.
 - c. Try resetting the **Feed Gauge**.

Won't Feed

If the **PSM3000** won't feed forms through:

1. Try reducing the size of the paper stack on the **Feed Table**.
2. Try resetting the Feed Gauge.

PSM3000 Won't Run

If the **PSM3000** won't run when the On-Off switch is operated:

1. Check that the **PSM3000 Power Switch Breaker**, located by the power plug, is not in the tripped (out) position. If it is, press it in. If the breaker button will not stay pressed in, wait a minute and try again.
2. Check that the **Access Panel** on the side cover opposite the control panel is properly in place.
3. Make sure the power switch by the power cord is in the On position.
4. Double-check that the power cord is properly connected to the machine and an appropriate socket [see Machine Setup].
5. Check that the wall socket which the machine is connected to is functioning properly.

Table of Contents

Operator Safety	1
Introduction	2
Unpacking and Setup	3
Unpacking	3
Setup	4
PSM3000 Overview	5
PSM3000 Diagram	5
Capabilities	5
PSM3000 Operation	6
Identifying Your Fold	6
Feed Table Setup	6
Setting the Paper Guide Width	6
Setting the Feed Gauge	7
Loading the Feed Table	8
Setting the Fold Plates	9
To Set a Fold Plate	9
Fold Plates	10
Maintenance	11
Troubleshooting	12
Automatically Clearing a Paper Jam	12
Manually Clearing a Paper Jam	12
Diagnosing the Paper Jam	12
Misaligned Folds	13
Paper Feed Problems	14
Double Feeds	14
Won't Feed	14
PSM3000 Won't Run	14

Problem	Double Feed	Buckled Form	FoldSymptom
Symptom	Unfold the form that caused the jam, you will find that it is actually two forms folded together.	There will be an extra fold in form near the correct fold location.	The form which caused the jam will be folded crooked.
Causes	<ul style="list-style-type: none"> • Bad Feed Gauge Setting • Too much paper on the feed table 	<ul style="list-style-type: none"> • Wrong fold plate setting 	<ul style="list-style-type: none"> • Feed Table Paper Guide set improperly • Fold Plates set improperly
Solution	¼ Turn CCW on feed gauge adjust screw	Check both fold plates. Make sure they are set to the correct mark on the scale.	Check both fold plates. Make sure that both paper stops are square.

Table 3: Paper Jam Diagnostics

Misaligned Folds

If your forms are running through the machine OK but they're folding a little bit crooked or are not folding right on the perforation, you need to tweak the fold plate settings. The location of perforations on forms generally fluctuates by about 1/16" in either direction. Forms manufacturers do this to avoid the forms sticking together too much. Because of this fluctuation, it is sometimes necessary to fine tune the placement of the paper stop on one of the fold plates.

The first step is to identify which fold plate is misaligned. Watch the form as it is fed into the machine, and then compare it to the finished form. If you're having trouble visualizing which fold is off, refer to the ***section Loading the Feed Table*** above.

Once you've identified which fold plate needs to be adjusted, remove it from the ***PSM3000***. If the fold is crooked, check to make sure that the paper stop is parallel to the front edge of the fold plate. Check that the indicator points on the paper stop indicate the same reading on the two scales of the fold plate. Also check the feed table to make sure that paper guides are snug against the paper stack. If the fold is just a bit off of the perforation, adjust the paper stop by the amount that the fold is off. If the fold is happening early, then move the paper stop away from the open end of the fold plate. If the fold is happening late, then move the paper stop towards the open end of the fold plate.

Troubleshooting

Automatically Clearing a Paper Jam

If paper becomes jammed in the **PSM3000**:

1. Remove all paper from the Feed Table.
2. If the Breaker Power Switch has tripped (light is off) then flip into the on (lighted) position.
3. Remove the Lower Fold Plate.
4. Press the Reverse button.
5. The paper should exit from the back (where the lower fold plate normally sits). If it does not, try pressing the Reverse button again. If the paper is not moving or you cannot see it, then you need to manually clear the jam [see next section].
6. Replace the Lower Fold Plate.

Manually Clearing a Paper Jam

1. Disconnect the power cord from the **PSM3000**.



Make sure that the power cord has been disconnected before continuing!

2. Remove all paper from the Feed Table.
3. Remove the Lower Fold Plate from the **PSM3000**.
4. Remove the access panel in the side cover.
5. Place the Breaker Bar socket over the hex end of the #3 roller [Figure 14].
6. Rotate the breaker bar clockwise until the jammed form is out of the v.
7. Replace the lower fold plate.
8. Replace the paper on the feed table.
9. Return the breaker bar to the toolkit.
10. Replace the side cover access panel.
11. Make sure that the power switch is in the off position.
12. Connect the power cord to the **PSM3000**.

Diagnosing the Paper Jam

Table 3 outlines the different problems which cause paper jams and the symptoms which will help you to identify the cause.

Operator Safety

- Please review and follow all the safety precautions to ensure safe equipment operation. The user is responsible for safe operating conditions. Read all operating instructions prior to operating the **PSM3000**.



Warning: Do not attempt to handle the equipment alone. It requires two people to handle and lift the equipment out of the packaging.



Warning: This unit contains moving parts. Watch for **Caution**, **Warning**, and **Electrical** stickers detailing proper operating conditions and user safety.

- **Never remove guards or product safety switches.** Removal of guards or switches will cause the unit to run improperly and can result in personal injury.
- **Keep all hands, fingers and objects away from moving parts.** Never attempt to reach into the **PSM3000** while the power is on. Turn off the **PSM3000** and disconnect the power cord before cleaning or servicing the **PSM3000**, and before removing either fold plate. Injury may occur if proper operating procedure is not followed.
- **Plug the power cord into 115 VAC 60 Hz outlet only.** Voltage up to 120 volts will not damage the **PSM3000**.
- The Power Cord and Plug must be accessible at all times for disconnection.
- This unit is equipped with a 3-Wire grounded electrical cord. If the cord becomes damaged and needs to be replaced, it must be replaced with an authorized part available through the manufacturer or an authorized service agent.
- All **PSM3000** maintenance should be performed only by factory authorized service personnel using factory authorized replacement parts. Contact your reseller for more information.
- Keep product away from extreme heat & moisture.
- Never operate **PSM3000** while tired, drowsy, or under the influence of medication, drugs, or alcohol. Failure to do so can result in personal injury.
- Never operate unit with loose clothing or jewelry. Contain all long hair and neck ties prior to operating **PSM3000**. Failure to do so could result in clothing, jewelry, or hair becoming entangled in moving parts.

Introduction

The **PSM3000** is designed to fold and seal up to 3000 documents per hour. Patented folding & sealing technologies ensure a good seal on every form and a clean fold every time whether the paper is perforated or plain. The adjustable fold plates allow the **PSM3000** to meet your changing document processing requirements. Below are the detailed **PSM3000** specs.

Feed System	Bottom Feed Friction Belt	
Drive System	A.C. Fixed	
Electrical	115V AC, 60 Hz, 3A	
Paper Sizes	Length up to 14", width up to 8.5"	
Fold Patterns	11" Half (V) 11" Letter C 11" Z	14" Half (V) 14" C 14" Return Envelope (EC) 14" Z 14" ECC Z
Speed	3000 Documents Per Hour Fixed Continuous	
Dimensions	Height 12", Width 20", Depth 16.5"	
Weight	55 Lbs.	

Maintenance

Regular maintenance on the **PSM3000** will ensure that it continues to function properly and will extend the life of the **PSM3000**. Perform the following steps every 10,000 forms or once a month:

1. Disconnect the power cord from the **PSM3000**.
2. Remove both fold plates.
3. Vacuum any paper dust or toner that has accumulated on the feed table and on the rollers.



Make sure that the power cord has been disconnected before continuing!

4. Open the access panel in the side cover opposite the control panel.
5. Insert the 7/16" socket at the end of the breaker bar over the hex shaped end on the #3 roller [Figure 14]. This bar can now be used to rotate the rollers.
6. Clean the **stainless steel rollers** with a household cleaner such as **Oops** in order to remove any accumulated toner. As you clean, use the breaker bar to rotate the rollers so that the entire roller surface is cleaned.
7. Clean the **rubber rollers** and the **feed belts** using a **rubber roll rejuvenator** [available at your local office supply store]. Use the breaker bar to rotate the rolls and feed belt as you clean so that all the rubber surfaces are cleaned.
8. Return the breaker bar to the toolkit and replace the access panel.
9. Replace the fold plates.
10. Make sure that the **power switch** is in the **Off** position.
11. Connect the power cord to the **PSM3000**.

5. Tighten the thumb screws, being careful that the paper stop does not slide out of square.
6. Return the Fold Plate to the machine, making sure that it is resting properly on the placement pins [see Setup Procedure].
 - a. If you are doing a **V Fold**, replace the **Lower Fold Plate** backwards, so that the flat face is facing in and the slot is facing out.

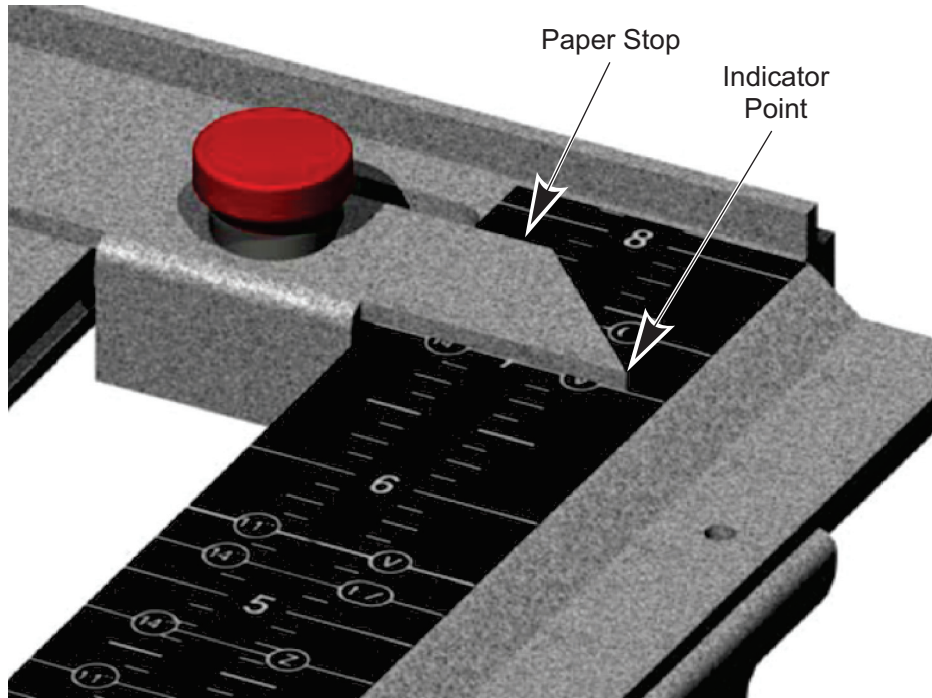

Figure 9: Paper Stop Alignment

For a custom form, the fold plate scales measure distance in inches from the fold, so the paper stop can be set to the appropriate measurement. If you are unclear about the figures to use, you can measure the lengths of the folds on your form (the distance from the perforations or fold marks to the edge of the paper) or contact your form supplier for more information.

Fold Plates

The **PSM3000** is equipped with adjustable fold plates. The red thumb screws can be loosened to allow you to move the paper stop to the correct position for your form and then tightened to hold the stop in place. All standard folds are marked on the scales of both the upper and lower fold plates. Set both fold plates to the desired setting (i.e. 11" Z) in order to perform that fold. See **PSM3000 Operation** for more information.

Unpacking and Setup

Unpacking

When opening the **PSM3000** packaging, inspect it for any shipping damage. The shipper should be notified at once and the packing materials saved if there is any serious damage.



Warning: Do not attempt to remove the equipment from the packaging alone. Two people are required at all times to move the equipment.

Ensure that the following items are

present in the packaging:

1. This manual (1)
2. PSM3000 (1)
3. AC Power Cord (1)
4. Upper & Lower Fold Plates (1 each)
5. Tool Kit
 - a. Breaker bar & 7/16" Socket
 - b. 3/16" T-Handle Hex Driver

If any items are missing please contact your reseller before continuing.

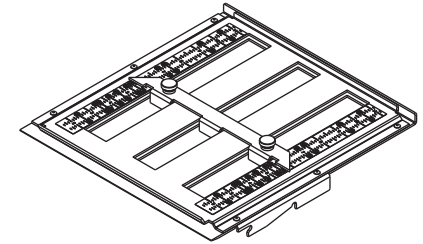

Figure 1: Upper Fold Plate

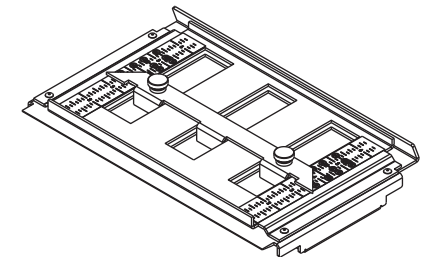

Figure 2: Lower Fold Plate

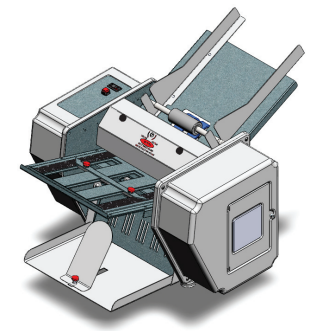



Figure 3: PSM3000

Setup

 **Warning:** Do not attempt to remove the equipment from the packaging alone. Two people are required at all times to move the equipment.

Place the **PSM3000** on a sturdy table or cart. Check to verify that both fold plates are properly installed [see Figures 4 & 5]. Both fold plates should rest snugly on the placement pins

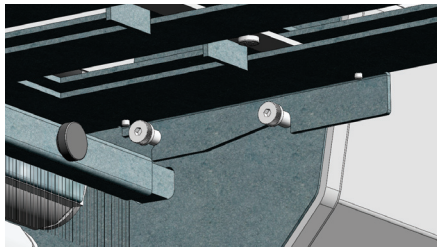



Figure 4: Upper Fold Plate in Proper Position



Figure 5: Lower Fold Plate in Proper Position

Insert the power cord into the **PSM3000** first, and then into a standard 115V AC 60 Hz outlet.

 The power cord must be accessible for disconnect.

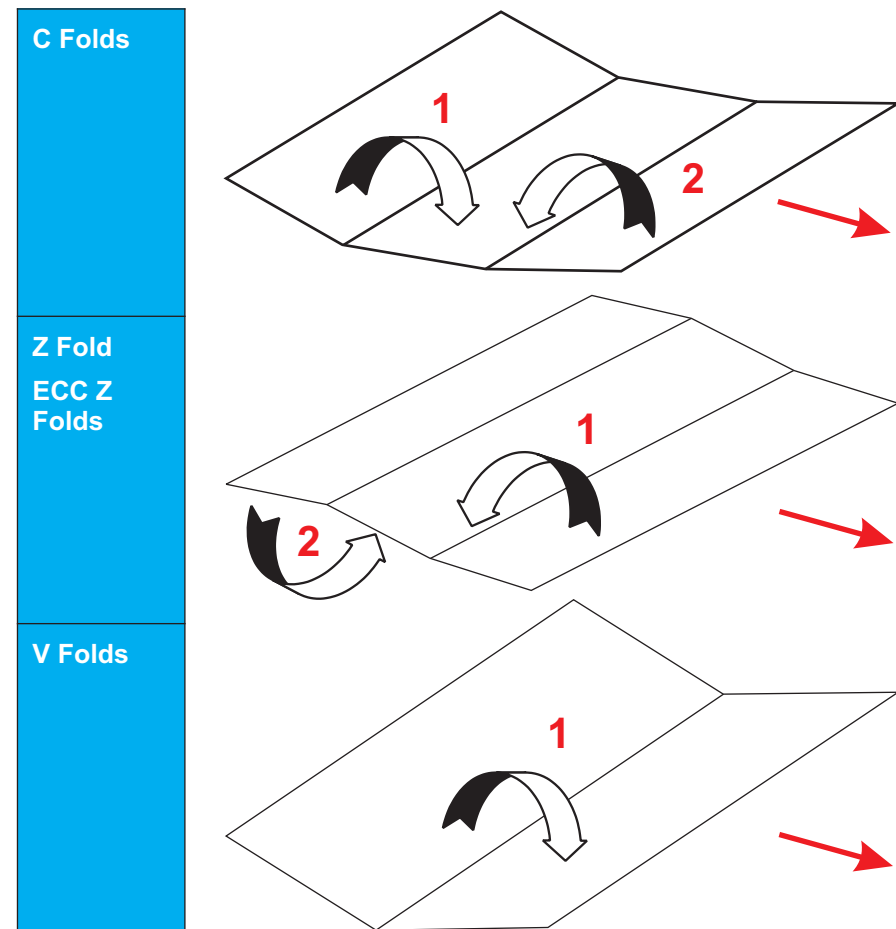

Table 2: Paper Loading & Fold Order

Setting the Fold Plates

To set a fold plate:

1. Remove the fold plate from the machine.
2. Loosen the thumb screws by turning counter-clockwise
3. Line up the tips on both sides of the paper stop with the appropriate line on the scale so that the appropriate white line on the scale is just visible [see Figure 9].
 - a. If you are doing a **V Fold**, you do not have to set the paper stop on the **Lower Fold Plate**.
4. Make sure that the paper stop is setup square by double-checking that the scales on both sides show the same fold selected or the same inch reading.

1. Remove all paper from the feed table.
2. Insert the provided **3/16" T-Handle Hex Driver** into **Feed Gauge Adjustment Screw**.
3. Turn the **T-Handle Hex Driver** ¼ turn clockwise to loosen the **Feed Gauge Roll**.
4. Place one form on the feed table and hand feed the form about 2 inches into the **PSM3000** by moving the feed belt with your hand.
5. Turn the **T-Handle Hex Driver** ¼ turn counter-clockwise.
6. Pull the paper out of the machine. You should feel resistance, but not too much. Repeat steps 4-6 until there is a moderate amount of resistance when pulling the form out. If it feels too tight, turn the T-Handle Hex Driver ¼ turn clockwise.
6. Return the T-Handle Hex Driver to the toolkit.

Loading the Feed Table

Before loading the feed table, square up the stack of paper you are going to load by placing it on edge on a flat surface. Place the stack onto the table so that the front of the stack butts up against the feed gauge cover [do not push hard].

The proper orientation of the paper when loaded onto the feed table depends on the type of fold you are doing and the layout of your form. Table 2 shows the order in which folds will be performed when run through the machine with the right hand paper edge being loaded into the machine first (red arrow shows paper path).

All forms should be loaded with glue on the leading edge facing up (the glue is usually visible as yellow, blue or red stripes around the edge of the form). With **Z & EZ Folds** you have multiple ways to load the form and still have glue on the leading edge facing up, either one will work. With **EZ Folds**, though, care must be taken to ensure that the upper fold plate is set to the proper length for the leading fold (the bottom fold plate setting remains the same either way).

Feed Table Capacities

- 11" Forms: 150 Sheets
- 14" Forms: 100 Sheets

PSM3000 Overview

PSM3000 Diagram

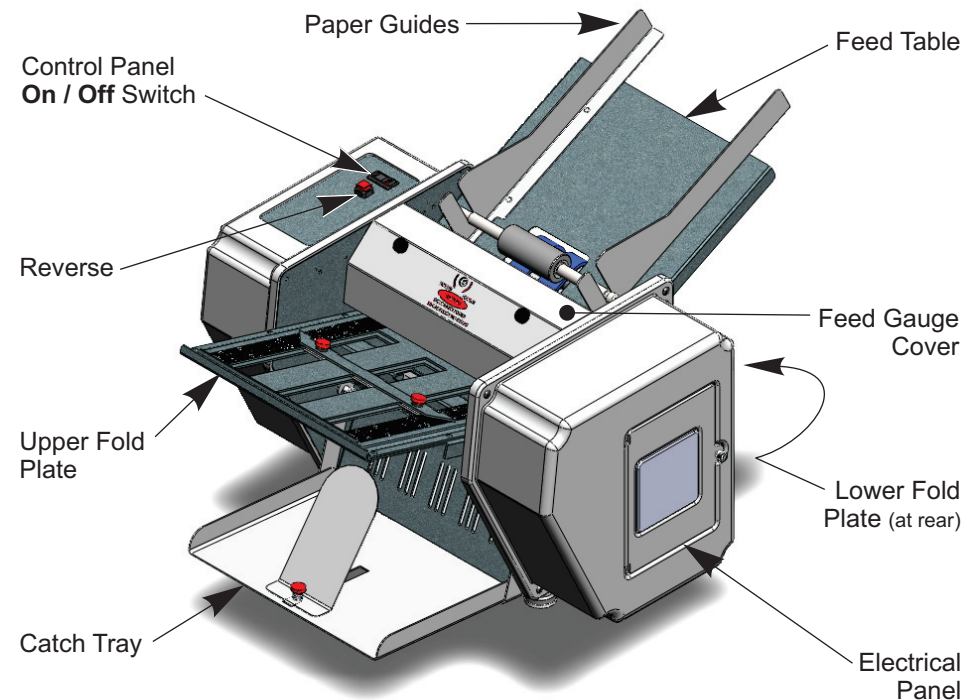

Figure 6: PSM3000 Diagram

Capabilities

- Your **PSM3000** is designed from the ground up to be a versatile folding and sealing **PSM3000**. Its capabilities include:
- Folding plain paper and forms from 20lb paper to 80lb stock.
- Folding all standard fold patterns [see Table 1].
- Single fold capability: when the bottom fold plate is in the half fold position, the upper fold plate can be set to lengths other than the standard **V Fold** depending on your special needs.

PSM3000 Operation

Identifying Your Fold

1. Identify your paper size. 11" forms are the standard letter size; 14" forms are the standard legal size. Measure the form if necessary.
2. Identify the fold shape from Table 1. Note that **ECC Z (EZ) Folds** are a similar shape as the standard **Z Fold**, but the lengths of the folds are not equal.

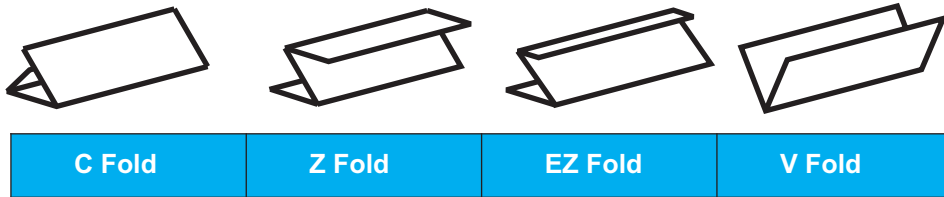
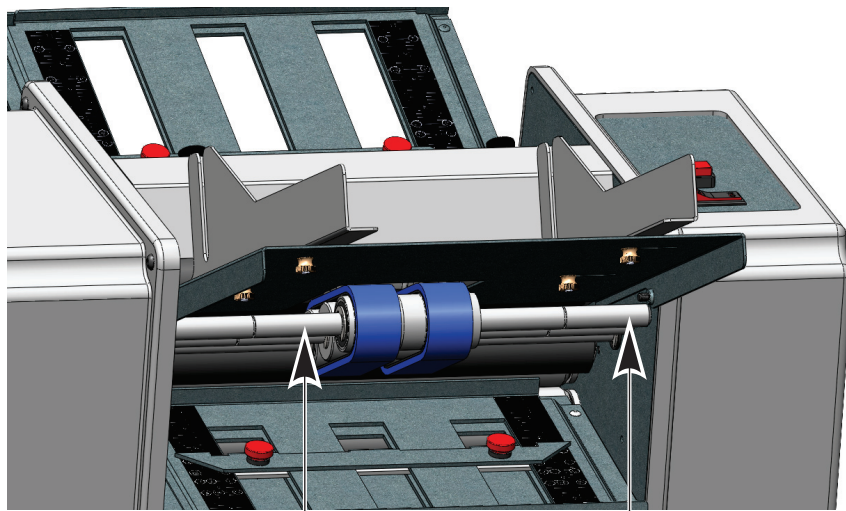

Table 1: Fold Types

Feed Table Setup

Setting the Paper Guide Width



Thumbscrews (4)

Power Switch Breaker
(by power plug)

Figure 9: Feed Table Diagram

To set the width of the **Feed Table Paper Guides** [see Figure 9]:

1. Loosen the red **Paper Guide** adjustment knobs. Don't fully remove them. 1-2 turns clockwise will loosen them.
2. Place a 1/2" stack of the form to be run on the feed table.
3. Line the paper stack up against the stationery paper guide.
4. Push the moveable paper guide up against the paper stack so that all the paper is aligned and the paper guide is snug against the side of the stack.
5. Hold the moveable guide in place with one hand and tighten the adjustment knobs with the other.

Setting the Feed Gauge

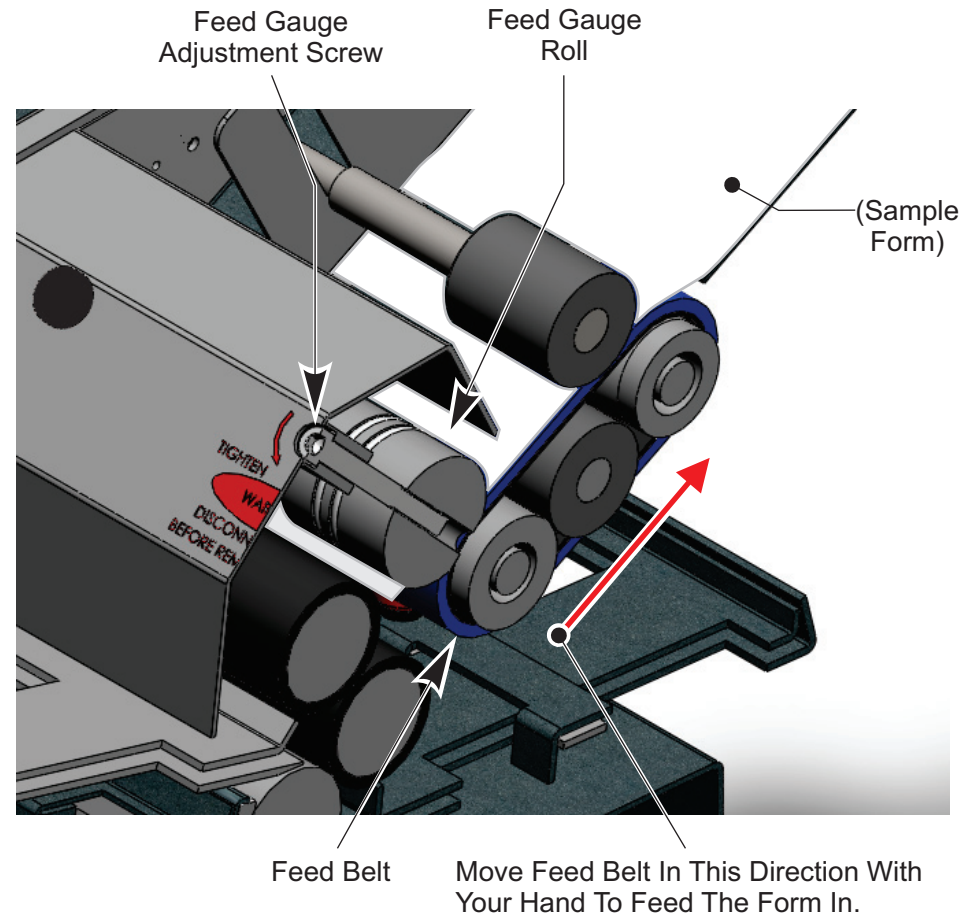

Figure 8: Feed Gauge Cross Section View

To properly set the **Feed Gauge System** [see Figure 8]:



Make sure that the **power switch** is in the **off** position.