

Medium Duty Industrial Cable Reels

Earthing Reels

SIMBAL earthing reels are the ideal solution for a wide range of standard applications. These drums come as an integral unit with pre-fitted green / yellow earth cable and a swiveling wall mounting bracket. They are available with cable sections up to 25mm² and with various payout lengths, for exact specifications please see data on the facing page.

Features:

- Green / Yellow earth cable (H05VV-F)
- Shock resistant plastic external case (Die cast aluminium on series 6000 drums)
- Cable roller guide
- Ratchet stop every 50mm (easily disconnected if not required)
- Double earth contact
- Collector insulating power - 2.5Kv
- Brass sliprings & brushes
- IP42 Protection (IP65 available on some models)
- Working temperature -5 / +40 deg C
- Available with both PVC & Rubber cable



Possible applications

SIMBAL earthing reels provide a convenient solution to a wide range of industrial and domestic applications where a product, or a piece of machinery requires an earth connection.

Optional extras

Standard options which can be fitted to SIMBAL earthing reels include a range of earth clips (including type 723 ATEX clip), IP65 protection seals & fixing bolts to restrict the swivel action of fixing bracket. A range of cable roller guides is also available to compliment the full range of drums. Other drums available in the range include 230V single phase, 400V 3 phase reels and a variety of different drums for special applications such as battery charging and electric vehicle charging.

Technical Data

Please see the following sheets for technical and dimensional data

Technical Data

| | | Cable size | Cable payout | Cable diameter | V | Max power @ 20 deg C | Slip rings | Max voltage | Cable type | Case colour |
|--|----------|-------------------------|--------------|----------------|---|---|------------|-------------|------------|-------------|
| Single core cable (Earth reels) | | | | | | | | | | |
| 5836/XF | 5897/XL | 1c x 2.5mm ² | 15 + 1.5m | 5.5mm | | Green / Yellow cable without thermal protection suitable for earthing | 10A | | H05VV-F | Yellow |
| 9106 | | 1c x 6mm ² | 6 + 1m | 5.5mm | | | 10A | | H05VV-F | Black |
| 5834/XF | 5896/XL | 1c x 6mm ² | 12.5 + 1.5m | 5.5mm | | | 10A | | H05VV-F | Yellow |
| 5832/XF | 5894/XL | 1c x 16mm ² | 8.5 + 1.5m | 8mm | | | 10A | | H05VV-F | Yellow |
| 6198/PRC | 6340/PRL | 1c x 2.5mm ² | 28 + 2m | 5.5mm | | | 10A | | H05VV-F | Silver |
| 6195/PRC | 6386/PRL | 1c x 6mm ² | 24 + 2m | 5.5mm | | | 20A | | H05VV-F | Silver |
| 6193/PRC | 6384/PRL | 1c x 16mm ² | 15 + 2m | 8mm | | | 20A | | H05VV-F | Silver |
| 7116 | | 1c x 16mm ² | 22m | 8mm | | | 10A | | H05VV-F | Grey |
| 1420 | | 1c x 16mm ² | 22m | 8mm | | | 50A | | H05VV-F | Steel+Black |
| 1421 | | 1c x 25mm ² | 20m | 10mm | | | 100A | | H05VV-F | Steel+Black |
| 1711 | | 1c x 16mm ² | 30 x 2m | 8mm | | | 60A | | H05VV-F | Steel+Black |
| 1712 | | 1c x 25mm ² | 30 x 2m | 10mm | | | 100A | | H05VV-F | Steel+Black |
| 4106 | | 1c x 6mm ² | 16m | 5.5mm | | | 10A | | H05VV-F | Yellow |
| 4116 | | 1c x 16mm ² | 11m | 8mm | | | 10A | | H05VV-F | Yellow |

We reserve the right to amend all technical details without prior notification

Medium Duty Industrial Cable Reels

Earthing Reels

Series 9000

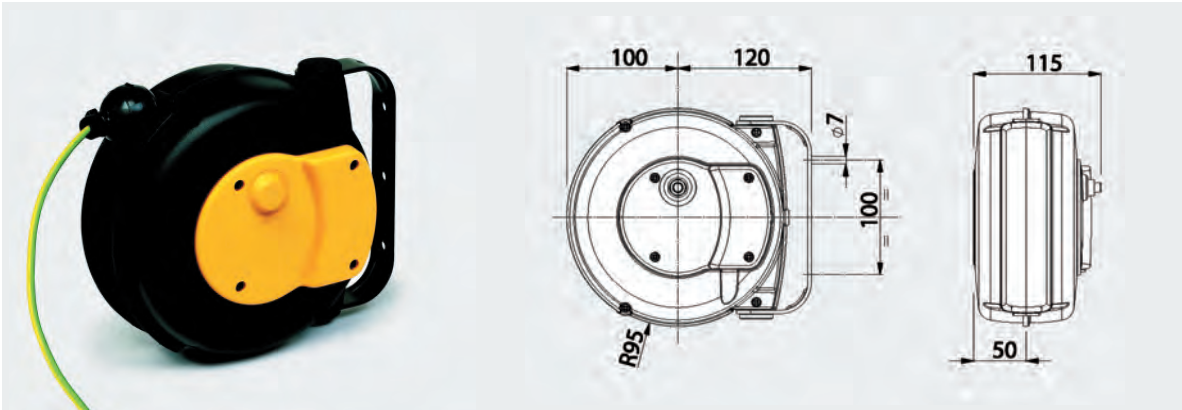

Series 5000/XF

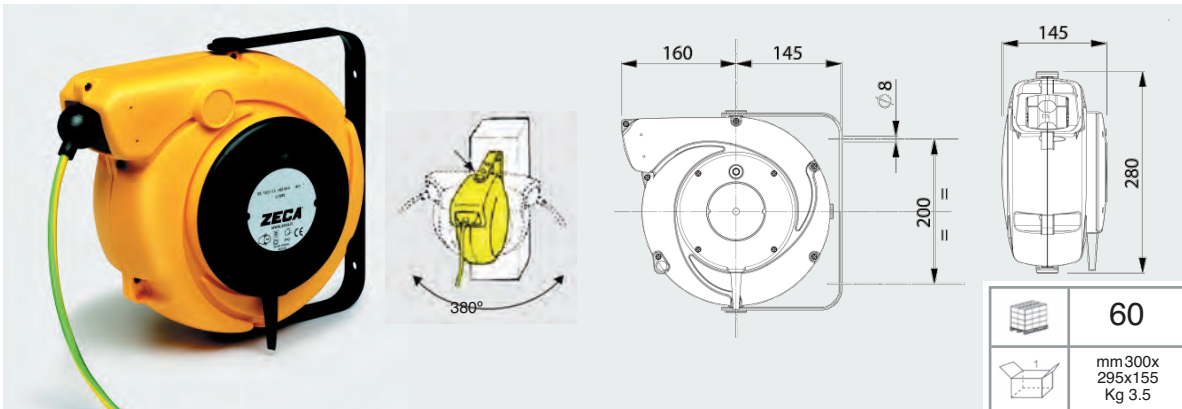

Series 5000/XL

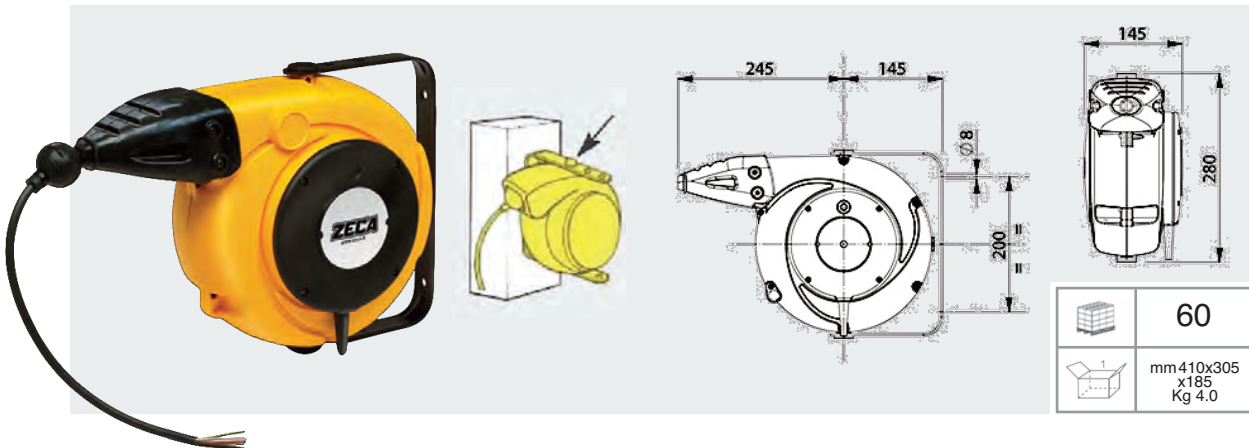



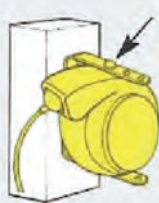
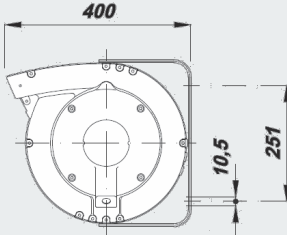
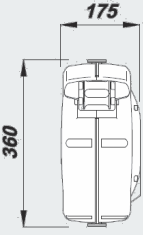

Medium Duty Industrial Cable Reels

Earthing Reels



Series 6000/PRC

| | |
|--|-----------------------------|
|  | 30 |
|  | mm 400x370 x190 Kg 13 |

| | |
|---|-----------------------------|
|  | 24 |
|  | mm 400x390 x290 Kg 13 |

Series 6000/PRL

380°

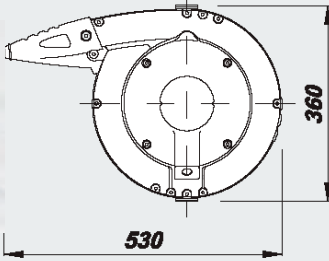
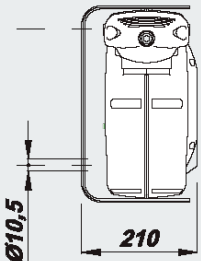
530

360

251

Ø10,5

210

Series 7000

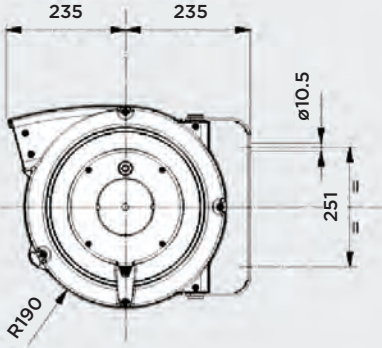
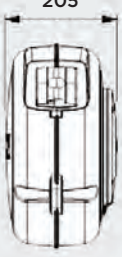
235



235



205

Ø10,5

251

R190

| | |
|--|---|
| Manufactured according to standard: Construit selon norme: EN 61242 EN 60335-1 | |
|  |  |
| These products comply with Directives: Produits conformes aux Directives: 2006/95/CE 2006/42/CE 2002/95/CE | |

| | |
|---|-----------------------------------|
|  | 20 |
|  | mm 430x400 x210 Kg 8.0-10.0 |

Medium Duty Industrial Cable Reels

Earthing Reels

Series 1400

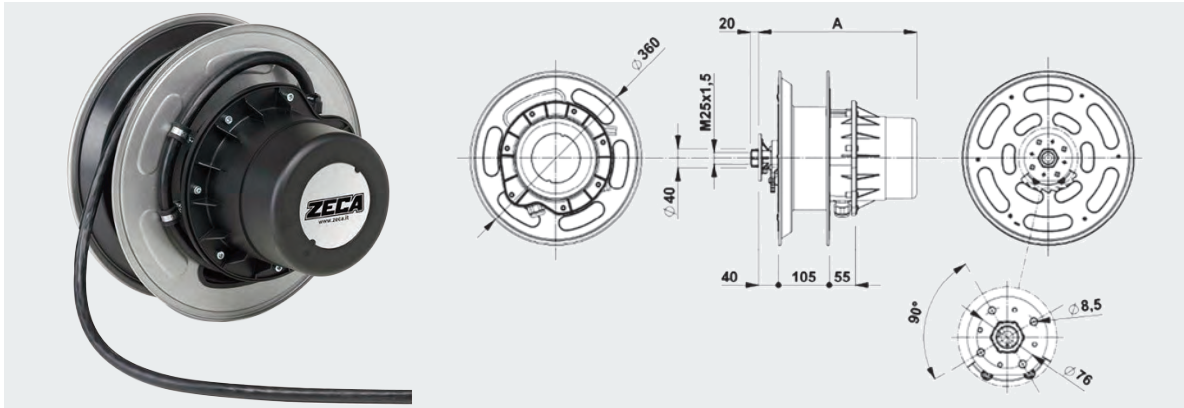

Series 1700

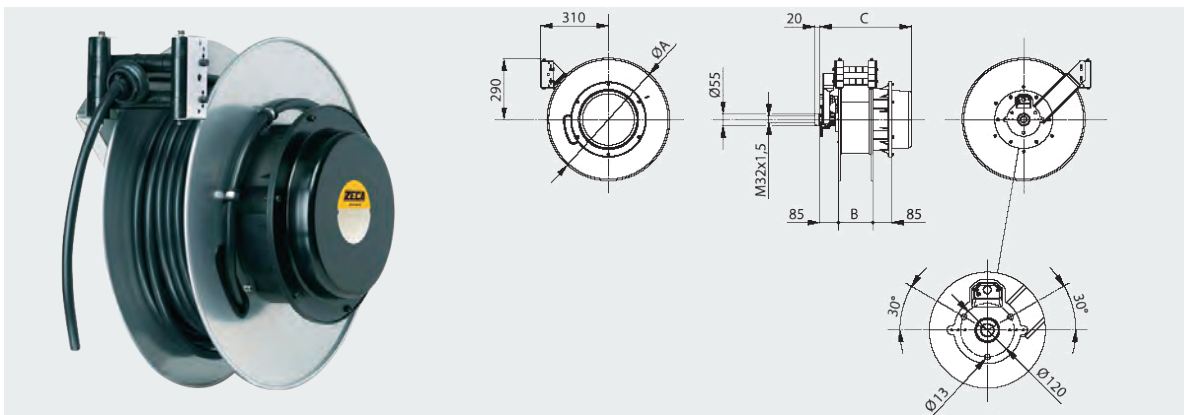

Specification

Working temperature - 5 deg C / +40 deg C

Series 5000 & 7000 Cable Reels have an external case manufactured from shock resistant plastic and are suitable for applications both with cable manually controlled and fitted on machines with automatic cable retraction. This range of drums features a ratchet stop every 50cm which can be easily disconnected if constant traction of cable is required. All springs have brass rings and bushes.

Series 6000 Cable Reels are similar to the above but have an

external case manufactured from die cast aluminum.

Standard Options include:

- 5100- Rubber cable sleeve (conversion from XF to XL)
- 6100- Rubber cable sleeve (conversion from PRC to PRL)
- Please enquire for specials such as rubber cable & IP55 Protection

Also available is a range of roller guides.

Medium Duty Industrial Cable Reels

Earthing Reels

A range of earth clips are available as optional items with SIMBAL earthing reels, details are shown below:-

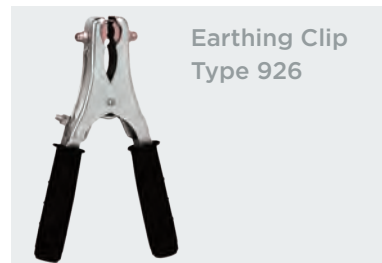
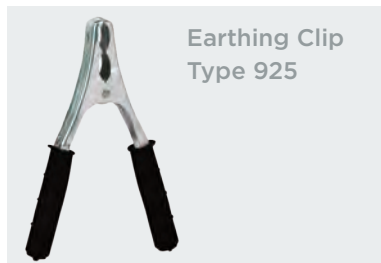
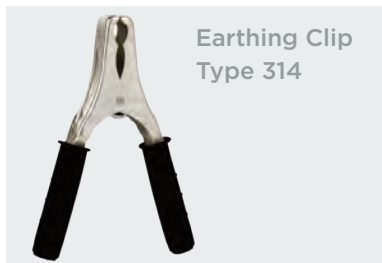

Explosion proof earthing reels



Technical Data

SIMBAL presents a series of ATEX products designed and manufactured for operation in hazardous areas covered by the certification under EC Directive 94/9/EC II 2G / II 2D EC and testing certificate BVS 10 ATEX E 84 type. There are three different size / types as listed alongside.

CR7K Cable Winder

Complete with 10 metre cable 1x10mm² + clamp.
Labelling pursuant to EC Directive 94/9/EC II 2G / II 2D EC and testing certificate BVS 10 ATEX E 84 type. Drum casing from yellow shock resistant plastic.

CRXK Cable Winder

Complete with 20 metre cable 1x10mm² + clamp.
Labelling pursuant to EC Directive 94/9/EC II 2G / II 2D EC and testing certificate BVS 10 ATEX E 84 type. Drum casing from grey shock resistant plastic.

CRXA Cable Winder

Complete with 20 metre cable 1x10mm² + clamp.
Labelling pursuant to EC Directive 94/9/EC II 2G / II 2D EC and testing certificate BVS 10 ATEX E 84 type. Drum casing from silver shock resistant plastic.