

# Medium Duty Industrial Cable Reels

## 400V 3 Phase Cable Reels

SIMBAL 400V 3 phase industrial cable reels are the ideal solution for a wide range of standard applications. These drums come as an integral unit with pre-fitted cable and a swiveling wall mounting bracket. They are available with cable sections up to 5 core x 2.5mm<sup>2</sup> and with various payout lengths, for exact specifications please see data on the facing page.

### Features:

- Shock resistant plastic external case (Die cast aluminium on series 6000 drums)
- Cable roller guide
- Ratchet stop every 50mm (easily disconnected if not required)
- Double earth contact
- Collector insulating power - 2.5Kv
- Brass sliprings & brushes
- IP42 Protection (IP65 available on some models)
- Working temperature -5 / +40 deg C
- Available with both PVC & Rubber cable



### Possible applications

Typical fields of application for our medium duty reels include power feed to monorail hoists, vertical feed from hoist down to grabs and lifting frames, plus many more applications across a wide range of industries.

Other reels in the range include 230V single phase reels, multicore cable reels and a wide variety of reels for special applications such as earthing reels, battery charging and electric vehicle charging. For further information please call our sales team on **01298 813883**, email: [sales@simbal.net](mailto:sales@simbal.net) or visit our website at [www.simbal.net](http://www.simbal.net)

### Optional extras

Standard options which can be fitted to SIMBAL 3 phase cable reels include rubber cables, IP65 protection seals & fixing bolts to restrict the swivel action of fixing bracket. A range of cable roller guides is also available to compliment the full range of drums.

### Technical Data

Please see the following sheets for technical and dimensional data

# Medium Duty Industrial Cable Reels

## 400V 3 Phase Cable Reels

Technical Data												
		Cable size	Cable payout	Cable diameter	V	Max power @ 20 deg C			Slip rings	Max voltage	Cable type	Case colour
<b>4 core cable</b>												
5824/XF	5878/XL	4c x 1.0mm <sup>2</sup>	10.5 + 1.5m	8mm	400V	1100W	400V	1600W	10A	500V	H05VV-F	Yellow
4415		4c x 1.5mm <sup>2</sup>	10 + 1m	8mm	400V	1400W	400V	1900W	10A	500V	H05VV-F	Yellow
5823/XF	5877/XL	4c x 1.5mm <sup>2</sup>	8 + 1.5m	9.5mm	400V	1350W	400V	1900W	10A	500V	H05VV-F	Yellow
7415		4c x 1.5mm <sup>2</sup>	25 + 2m	9.5mm	400V	1100W	400V	1800W	10A	500V	H05VV-F	Grey
5821/XF	5876/XL	4c x 2.5mm <sup>2</sup>	5.5 + 1.5m	11mm	400V	2000W	400V	2700W	10A	500V	H05VV-F	Yellow
5822/XF	5899/XL	4c x 2.5mm <sup>2</sup>	5.5 + 1.5m	11mm	400V	2000W	400V	2700W	20A	500V	H05VV-F	Yellow
4425		4c x 2.5mm <sup>2</sup>	8 + 1m	11mm	400V	2000W	400V	2700W	10A	500V	H05VV-F	Yellow
7425		4c x 2.5mm <sup>2</sup>	18 + 2m	11mm	400V	2000W	400V	3000W	10A	500V	H05VV-F	Grey
6182/PRC	6373/PRL	4c x 1.0mm <sup>2</sup>	24 + 2m	8mm	400V	800W	400V	1400W	10A	500V	H05VV-F	Silver
6181/PRC	6372/PRL	4c x 1.5mm <sup>2</sup>	21 + 2m	9.5mm	400V	1100W	400V	1800W	10A	500V	H05VV-F	Silver
6521/PRC	6525/PRL	4c x 2.5mm <sup>2</sup>	15 + 2m	11mm	400V	2000W	400V	3000W	20A	500V	H05VV-F	Silver
6458/PRC	6396/PRL	4c x 4mm <sup>2</sup>	8 + 2m	14mm	400V	3000W	400V	4000W	20A	500V	H05VV-F	Silver
<b>5 core cable</b>												
5844/XF	5875/XL	5c x 1.0mm <sup>2</sup>	7.5 + 1.5m	9mm	400V	1000W	400V	1500W	10A	500V	H05VV-F	Yellow
5843/XF	5874/XL	5c x 1.5mm <sup>2</sup>	5.5 + 1.5m	11mm	400V	1350W	400V	1900W	10A	500V	H05VV-F	Yellow
4515		5c x 1.5mm <sup>2</sup>	8 + 1m	9.5mm	400V	1400W	400V	1900W	10A	500V	H05VV-F	Yellow
7515		5c x 1.5mm <sup>2</sup>	20 + 2m	9.5mm	400V	1500W	400V	2200W	10A	500V	H05VV-F	Grey
7525		5c x 2.5mm <sup>2</sup>	15 + 2m	13mm	400V	2000W	400V	3000W	10A	500V	H05VV-F	Grey
6063/PRC	6136/PRL	5c x 1.0mm <sup>2</sup>	16 + 2m	9mm	400V	800W	400V	1400W	10A	500V	H05VV-F	Silver
6067/PRC	6140/PRL	5c x 1.5mm <sup>2</sup>	15 + 2m	11mm	400V	1500W	400V	2200W	10A	500V	H05VV-F	Silver
6022/PRC	6154/PRL	5c x 2.5mm <sup>2</sup>	10 + 2m	13mm	400V	2000W	400V	3000W	10A	500V	H05VV-F	Silver
6068/PRC	6156/PRL	5c x 2.5mm <sup>2</sup>	10 + 2m	13mm	400V	2000W	400V	3000W	20A	500V	H05VV-F	Silver

# Medium Duty Industrial Cable Reels

400V 3 Phase Cable Reels

## Series 4000

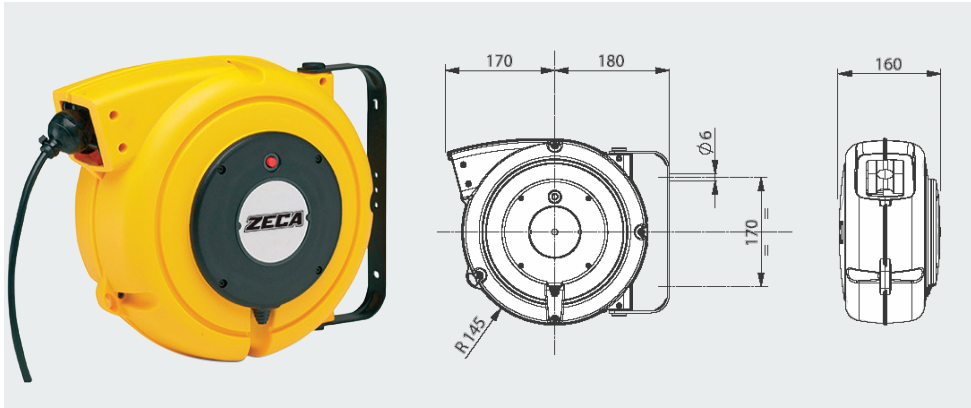

Manufactured according to standard:  
Construit selon norme:  
EN 61242 EN 60335-1



These products comply with Directives:  
Produits conformes aux Directives:  
2006/95/CE 2006/42/CE 2002/95/CE



44



mm335x310  
x185  
Kg 5

## Series 5000/XF

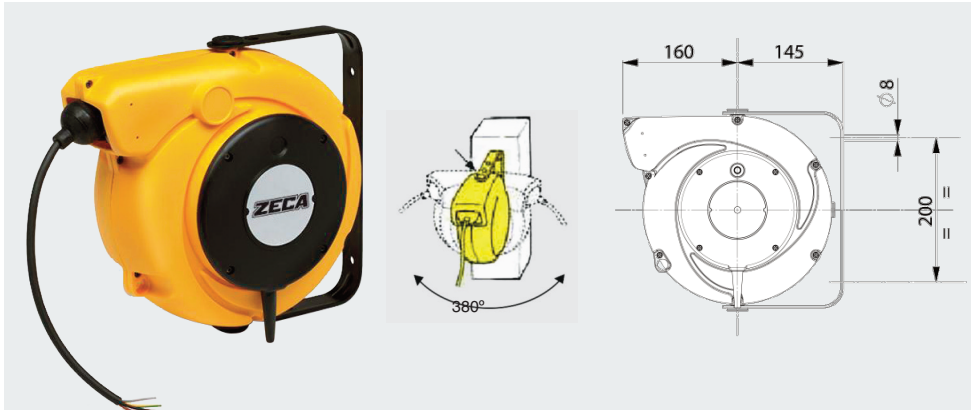

60



mm300x  
295x155  
Kg 3.5

## Series 5000/XL



60



mm410x305  
x185  
Kg 4.0

We reserve the right to amend all technical details without prior notification





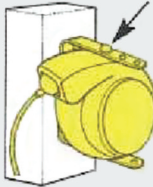
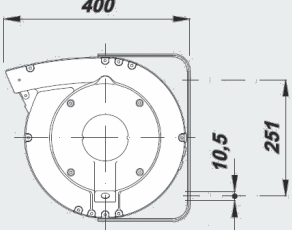
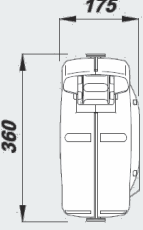

# Medium Duty Industrial Cable Reels

## 400V 3 Phase Cable Reels

### Series 6000/PRC

	<b>30</b>
	mm 400x370 x190 Kg 13



	<b>24</b>
	mm 400x390 x290 Kg 13

### Series 6000/PRL

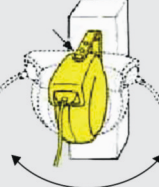
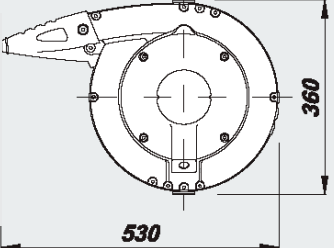
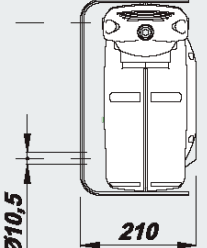

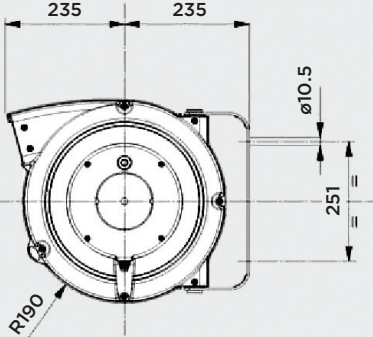
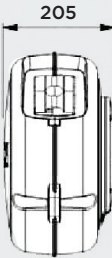



### Series 7000

Manufactured according to standard: Construit selon norme: EN 61242 EN 60335-1	
	

These products comply with Directives: Produits conformes aux Directives: 2006/95/CE 2006/42/CE 2002/95/CE	
--	--

	<b>20</b>
	mm 430x400 x210 Kg 8.0-10.0

### Specification

#### Working temperature - 5 deg C / +40 deg C

Series 5000 & 7000 Cable Reels have an external case manufactured from shock resistant plastic and are suitable for applications both with cable manually controlled and fitted on machines with automatic cable retraction. This range of drums features a ratchet stop every 50cm which can be easily disconnected if constant traction of cable is required. All springs have brass rings and bushes.

Series 6000 Cable Reels are similar to the above but have an external case manufactured from die cast aluminum.

#### Standard Options include:

- 5100- Rubber cable sleeve (conversion from XF to XL)
- 6100- Rubber cable sleeve (conversion from PRC to PRL)
- Please enquire for specials such as rubber cable & IP55 Protection

Also available is a range of roller guides.