

# ATEX Festoon Systems

## ATEX 'Ex' Rated Cable & Hose Carrying Systems



### Application

The festoon systems shown on the following pages are ATEX approved according to the requirements of Directive 94/9/EC and are in full compliance with EX 112GD c T6 T85deg C – INERIS 2010 file number DCE--EQEN No. 023320/10.



**The equipment is valid for use in areas and sites with a risk of explosive atmospheres and is approved for areas classified as Class 1 & 2 (Gas) and Class 21 & 22 (Dust).**

### Where :-

- Ex is the logo which identifies the certified equipment to be used in risk areas with explosive atmospheres.
- Group II covers equipment aimed at all sectors excluding the mining sector
- Category 2 represents equipment designed to provide a 'HIGH LEVEL OF PROTECTION' as interpreted by the equipment manufacturer
- Acronyms 'G' & 'D' signify that the equipment is designed for use in areas where the explosive risk is caused by either Gas (G) or Dust (D)
- Acronym 'c' represents the protection mode used for the design of the device, according to std. UNE-EN 13463-5, non electrical equipment for potentially explosive atmospheres. Part 5 – constructive security protection level 'c'
- The maximum surface temperature of the device i.e. the temperature which shall not be exceeded in any part of the device in any foreseeable failure condition is based on the class temperature T6 for gases and T85degC for powder or dust.
- The second set of characters refers to the identification number of the technical documents placed in custody by the notified body (INERIS)

### System Selection ATEX Approved Festoon Systems – System Type Selection

#### System 2310 Ex

System 2310 Ex is a 'C-Rail' section where trolleys run inside the track, this system is suitable for carrying flat cables in most applications where little or no dust is present and for straight runs only.

#### Trolley carrying capacity:

**System 2310 Ex – max cable stack = 80mm x 30mm, max trolley load = 10kg**

#### System 2336 Ex

System 2336 Ex is a 'C-Rail' section where trolleys run inside the track, this system is suitable for carrying round cables and/or hoses in most applications where little or no dust is present and for straight runs only. **Trolley carrying capacity: System 2336 Ex – max trolley load = 10kg**

#### System 2307 Ex

System 2307 Ex is a Diamond track section where trolleys run on the outside surface of a 'diamond' section' track, this system is suitable for carrying round cables and/or hoses in applications where significant amounts of dust are present, it is also the ideal solution for systems with curved sections.

**Trolley carrying capacity: System 2307 Ex – max trolley load = 10kg**

#### System 2347 Ex

System 2347 Ex trolleys and components are designed for running on standard 'I section beams' – they are suitable for most applications where heavier loads are to be carried.

**Trolley carrying capacity: System 2347 Ex – max trolley load = 30kg**

## ATEX Festoon Systems – System 2347 Ex

ATEX Ex rated Cable Trolleys suitable for carrying cables along Standard i-Beams in applications where heavier loads are to be carried. These trolleys are available for Flat & Round Cables in custom sizes to suit customer requirements.

End Clamp Ref. 2347-2-Ex

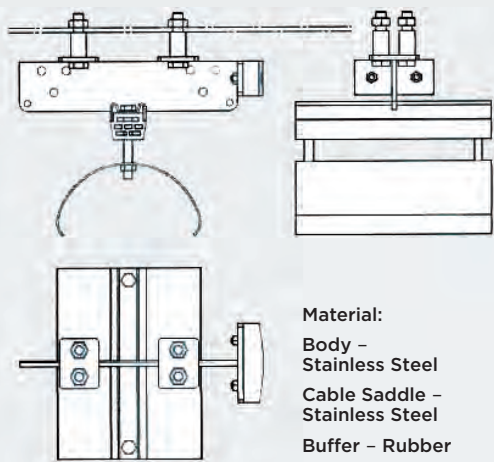

**Material:**

Body –  
Stainless Steel

Cable Saddle –  
Stainless Steel

Buffer – Rubber

Bolts, Nuts &  
Washers –  
Stainless Steel

Trolley capacity: 30kg

Cable Trolley Ref. 2347-5-Ex

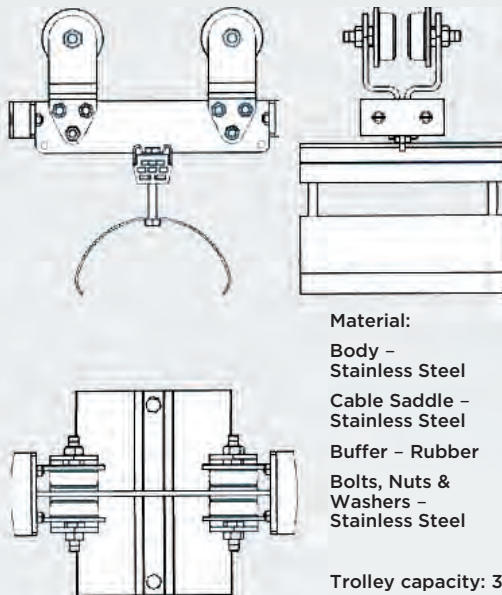

**Material:**

Body –  
Stainless Steel

Cable Saddle –  
Stainless Steel

Buffer – Rubber

Bolts, Nuts &  
Washers –  
Stainless Steel

Trolley capacity: 30kg

Towing Clamp Ref. 2347-6-Ex

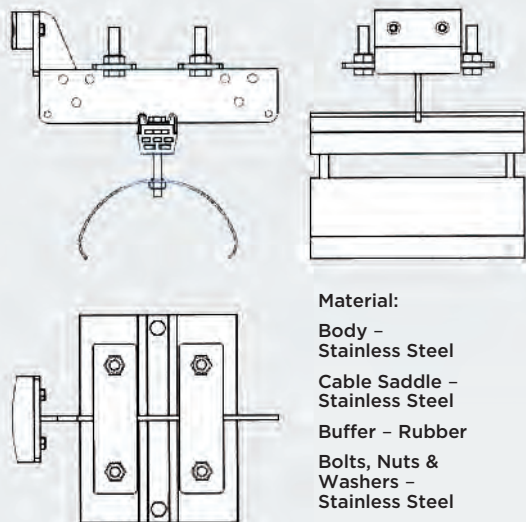

**Material:**

Body –  
Stainless Steel

Cable Saddle –  
Stainless Steel

Buffer – Rubber

Bolts, Nuts &  
Washers –  
Stainless Steel

Trolley capacity: 30kg

Towing Trolley Ref. 2347-6A-Ex

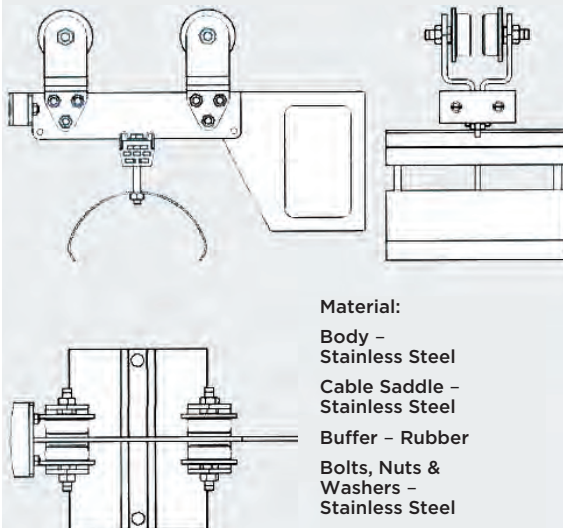

**Material:**

Body –  
Stainless Steel

Cable Saddle –  
Stainless Steel

Buffer – Rubber

Bolts, Nuts &  
Washers –  
Stainless Steel

Trolley capacity: 30kg