

9502AX-9509AX

9520AX-9525AX

	Aluminium	
	2100 mm	9502 AX- 9509AX
	2700 mm	9520 AX- 9525AX
	Stainless Steel	
	12 - 100 kg	

- Ribbed and sealed construction in aluminium alloy
- Stainless steel rope
- Adjustable capacity by worm screw
- Safety suspension
- Safety device against load dropping due to the spring breakage (capacity >3kg)
- Upper rotary suspension with safety hook
- Locking device to block the load at any height
- Adjustable stroke limiting device
- Taper drum rotating on ball bearings
- Cable guide in antifriction material
- Rotary upper hook with ball bearing
- Inert spring drum assembly
- Option F - Brake device - see below for details
- Option RC - Rotary hook

Option F Brake device

The balancer is equipped with a friction/brake which controls the rotation speed of the drum. This option is feasible when placing a new order while it is not possible to assemble this device on balancers already installed.

Option F



Control from the floor BC (7190000004)

Locking-unlocking device.



Option RC (7270000004)

Conductive rotating hook group.

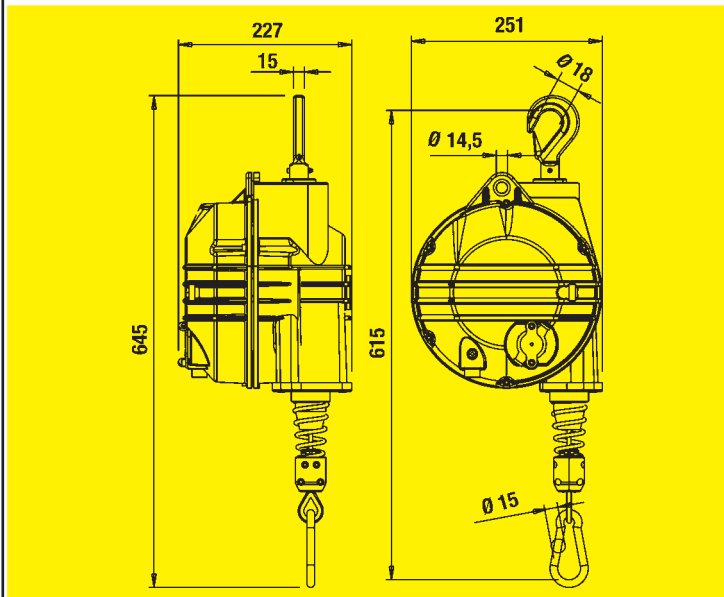

ATEX **COMPLIANT**

Explosive Atmospheres

II 2G Ex h IIA T6 Gb

II 2D Ex h IIIC T85°C Db

Item	9502AX	9503AX	9504AX	9505AX	9506AX	9507AX	9508AX	9509AX	9520AX	9521AX	9522AX	9523AX	9524AX	9525AX
kg	20-30	30-40	40-50	50-60	60-70	70-80	80-90	90-100	12-20	20-30	30-40	40-50	50-60	60-70
kg	12,60	15,20	15,50	16,70	15,50	17,70	16,20	16,80	12,80	12,60	15,80	15,40	16,60	15,70