

## 9354AX-9359AX



	Aluminium
	2000 mm
	Stainless Steel
	4 - 25 kg

- Ribbed and sealed construction in aluminium alloy
- Stainless steel rope
- Adjustable capacity by worm screw
- Safety suspension
- Safety device against load dropping due to the spring breakage (capacity >3kg)
- Upper rotary suspension with safety hook
- Locking device to block the load at any height
- Adjustable stroke limiting device
- Taper drum rotating on ball bearings
- Cable guide in antifriction material
- Rotary upper hook with ball bearing
- Inert spring drum assembly
- Option F - Brake device - see below for details
- Option RC - Rotary hook

### Option F Brake device

The balancer is equipped with a friction/brake which controls the rotation speed of the drum. This option is feasible when placing a new order while it is not possible to assemble this device on balancers already installed.

Option F

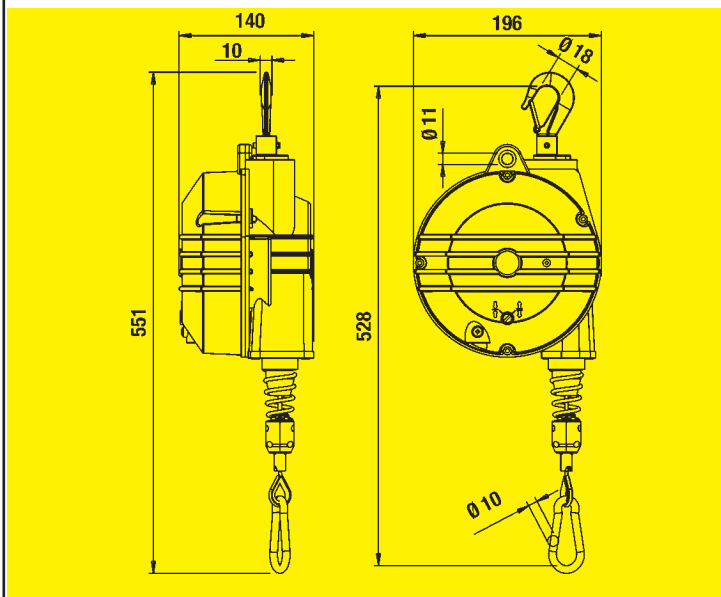

ATEX **Ex** COMPLIANT

Explosive Atmospheres

II 2G Ex h IIB T6 Gb (9354AX/9355AX)

II 2G Ex h IIA T6 Gb (9356AX-9359AX)

II 2D Ex h IIIC T85°C Db

Item	9354AX	9355AX	9356AX	9357AX	9358AX	9359AX
kg	4 - 7	7 - 10	10 - 14	14 - 18	18 - 22	22 - 25
kg	4,94	5,30	5,67	6,26	5,89	6,53