

Addendum No. 1
July 9, 2021

Project: Augustana University Softball Field Improvements
Sioux Falls, SD
#2925

Architect: Architecture Incorporated

Letting: Thursday July 15, 2021
2:00 PM
Augustana University, 2001 S. Summit Avenue

Scope of this Addendum:

To all bidders and all others to whom drawings and specifications have been issued by Architecture Incorporated, this Addendum forms a part of the Contract Documents. Acknowledge receipt of this addendum by listing its number and date in the bidder's Form of Proposal. Failure to do so may subject bidder to disqualification. This addendum modifies the drawings and specifications as follows:

GENERAL ITEMS:

1) PRE-BID MEETING MINUTES

- a) Reference the attached Meeting Minutes from the Pre-Bid Meeting held on 7/6/21.

2) SPECIFICATION SECTION 321817 – EXTERIOR ATHLETIC FIELD PADDING

- a) Padding supplier shall provide a unit price per square foot for custom printing on the outfield fence and backstop wall padding.
- b) Perm-Rail padding to be bid with custom printing the entire length on field side of padding.

3) DRAWING SHEETS 2.20 / 2.40 – EXISTING BLEACHERS

- a) CLARIFICATION: Reference drawing sheet 2.20 for demolition notes 23 / 24 regarding the existing bleachers. It is the responsibility of the contractor to move the existing bleachers during construction. All existing strands will be re-installed for the project.
 - i) The large center section will be installed west of the new grandstands in lieu of the right field location as noted.
 - ii) The two smaller sections (note 23) will be installed on the right field concrete pad (west of the visitor's dugout) in lieu of being salvaged to the owner as noted.

4) DRAWING SHEET 2.40 – SITE PLAN

- a) Omit Reference to Grandstands by Owner. Grandstands are to be provided by the project.

5) DRAWING SHEET 2.43

- a) CLARIFICATION: Under the base bid the contractor shall install salvaged chain link fabric in lieu of new vinyl coated chain link as noted on detail 6/2.43 (Base Bid).

MECHANICAL ITEMS:

NA

ELECTRICAL ITEMS:

1) ELECTRICAL DRAWING SHEET 9.10 – SITE PLAN – ELECTRICAL

- a) Provide (1) additional type “Z” fixture. See below for location (approximately 10’ setback from light pole).

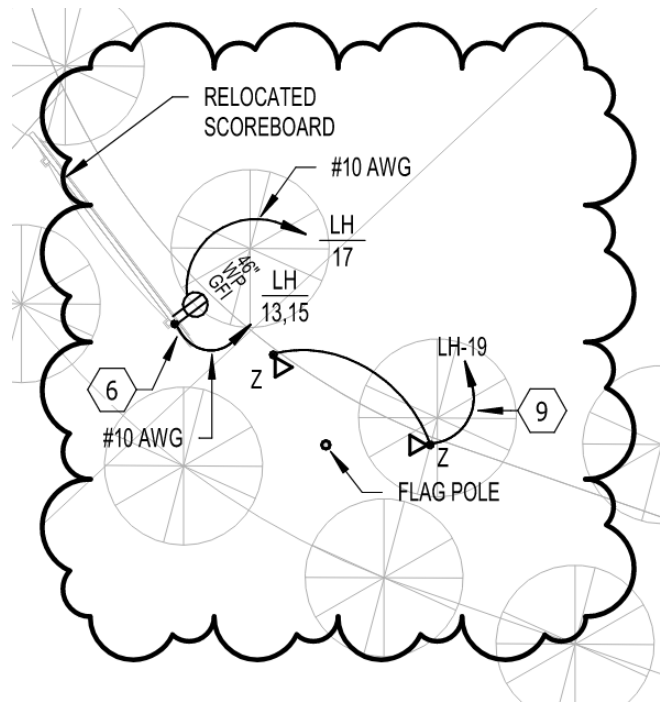

2) ELECTRICAL DRAWING SHEET 9.20 – ELECTRICAL SYMBOLS & ABBREVIATIONS

- a) Transformer Schedule: Transformer “XH” shall be rated at 45KVA in lieu of 30KVA.

3) ELECTRICAL DRAWING SHEET 9.21 – ELECTRICAL SCHEDULES

- a) In reference to the light fixture schedule:

- i. Type “Z” to be equal to NLS CAT#NV-F1 30 16L 45W 40K UNV TM TMS3 STP24 NGC BRZ. Provide fixture base per detail shown below.

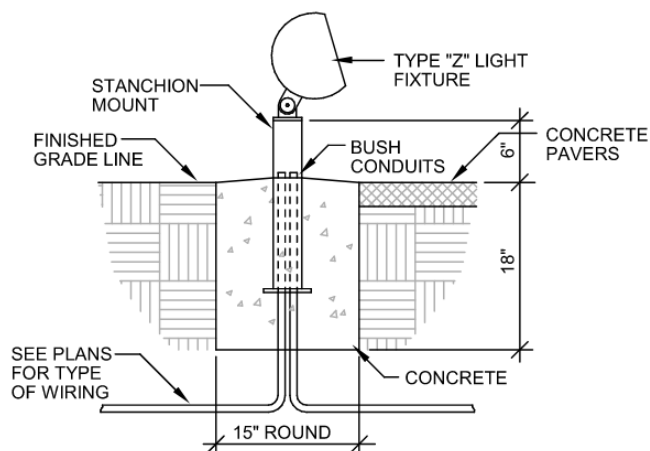

TYPE "Z" FLAG POLE LIGHT MOUNTING DETAIL

NO SCALE

- b) In reference to type "K1", fixture to have an overall projection length of 24" in lieu of standard 12".

GENERAL APPROVALS:

The following material or equipment furnished by the manufacturers listed, may be substituted as equivalent providing that each item, material, and piece of equipment conforms to the design and requirement of the specifications.

<u>SECTION</u>	<u>ITEM</u>	<u>MANUFACTURER</u>
131290	Permanent Grandstands	Hussey Fusion Legend
265110/265210	Interior/Exterior Lighting – Type K1	INSIGHT

END OF ADDENDUM

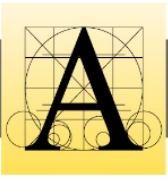

**Augustana University Softball Field Improvements
Pre Bid Meeting**

Architect's Project No.: 2925

Date: 7/6/2021

Present at the project site:

Andrew Eitreim, Architecture Incorporated
Luke Groth, Augustana University Athletics
Talis Johnson, Builders Electric
Jim Norgaard, Builders Electric
Steven Utech, First Rate Excavate
Lucas Fiegen, Fiegen Construction
Marshal Leifheit, Fiegen Construction
Billy Polema, Beck & Hofer Construction
Jordan Smithback, Electric Supply Co.
Merlyn Brockhouse, Alliance Construction
Greg Kunz, Electric Construction Co.
Gregg V., Muth Electric

The purpose of this meeting was to review the scope of work, delivery of bids, schedule, and respond to questions.

1. Introductions

- a. Andrew Eitreim is the Architect.
- b. Luke Groth is representing Augustana University Athletics.

2. Scope of Work

- a. The architect reviewed the scope of work which includes demolition of existing field elements (dugouts, pressbox, concrete sidewalks, fencing, tree stumps, etc), construction of new dugouts and pressbox structures including associated mechanical / electrical work, site concrete (sidewalks and retaining walls), field and perimeter fencing, and grandstands.
- b. There will be concurrent work on the project site under separate contracts with the University which include;
 - i. Field Turf by Mammoth Sports Construction

1. Includes excavation/grading within the footprint of the field, subgrade prep, engineered fill and turf.
 2. Reference Civil drawing sheet 2.30 for extent of field turf system.
- ii. Field Netting / Sports Lighting by Netex Canada Netting, Inc.
 1. Includes installation of netting / lighting poles, installation of netting system and luminaires.
- iii. Scoreboard by Daktronics.
 1. Includes removal of existing scoreboard and reinstallation on new structure.
- iv. Contractors will be expected to coordinate schedules with these scopes of work contracted directly with Augustana University.

3. Contractor Access / Staging / Parking

- a. The contractors will be allowed to utilize the open space east of the existing field for a staging area. Disturbed areas will need to be repaired and seeded.
- b. Contractor parking will be in along Lake Avenue to the west or the football parking lot to the south.
- c. The contractor will be responsible for securing the project site with a temporary construction fence located south of the project site and running from the baseball outfield fence to the chain link fence along Lake Avenue – final location of the fence to be coordinated with the Owner.

4. Bid Alternates

- a. There are four bid alternates described in the documents - reference specification section 012300.
 - i. Add Alternate #1: Add Outfield Fence Padding
 - ii. Add Alternate #2: Add Dugout Cubbies
 - iii. Add Alternate #3: Add Visitor Dugout Restroom
 - iv. Add Alternate #4: Add Performance Bond and Labor and Material Payment Bond

5. Allowances

- a. There are two allowances included in the project – reference specification section 012100.

6. Delivery of Bids

- a. Bids to be submitted to Andrea Smith, Director of Facility Services at 2001 S. Summit Avenue by 2:00 PM on Thursday, July 15, 2021.

7. Project Schedule

- a. Notice to Proceed is anticipated the week of July 19.
- b. Substantial completion: November 5, 2021.
- c. Final Completion: November 19, 2021.

8. Addenda

- a. None out currently.
- b. Addendum #1 planned for 7/9/21.
- c. Final Addendum #2 planned for 7/13/21, if necessary.
- d. If the Contractors have any questions, contact the Architect as soon as possible
 - i. Submit proposed substitutions for review as soon as possible.

9. Existing Bleachers

- a. The responsibility of moving and re-installing the existing bleachers will be clarified via addendum.

10. Questions raised by attendees – *responses in italics.*

- a. Who is responsible for setting the netting / lighting poles? *Netex Canada Netting will install the netting / lighting poles. The contractor will be responsible for installation of the concrete pole bases and the associated electrical work. Netex will provide the anchor cage bolts prior to the installation of the concrete pole bases.*

- b. Are there concerns regarding the availability of metal roof deck? *The dugout and pressbox structures were designed to accommodate 1 ½" or 3" metal deck to help with potential availability concerns. An alternate framing method will be considered if metal deck is not available.*
- c. Is there existing fence that is to be salvaged? *Yes, the documents show salvaging and re-installing the chainlink fabric, fence guard, top rail and mid rail. Existing vertical posts are to be removed and disposed.*

Respectfully submitted,

Andrew Eitreim

cc. Andrea Smith (Augustana University)
Josh Morton (Augustana University)
Luke Groth (Augustana University)
Attendees