

# UL25/UL32/UL40

## PUSH AROUND MAST LIFTS



- Robust push-around mast lifts
- Patented Girder Lock mast design for stable working up to 46ft.
- Compact dimensions
- Passes through a standard doorway
- Easy loader system for flatbed vehicle transport

 **snorkel**  
[www.snorkellifts.com](http://www.snorkellifts.com)

# PUSH AROUND MAST LIFTS

# UL25/UL32/UL40

| DIMENSIONS                   | UL25                   | UL32       | UL40                  |
|------------------------------|------------------------|------------|-----------------------|
| Max. working height          | 30 ft 11 in            | 37 ft 9 in | 46 ft                 |
| Max. platform height (A)     | 24 ft 11 in            | 31 ft 9 in | 40 ft                 |
| Platform length              | 22 in                  | 22 in      | 22 in                 |
| Platform width               | 26 in                  | 26 in      | 26 in                 |
| Stabilizer footprint (B x C) | 6 ft 10 in x 6 ft 6 in |            | 9 ft 8 in x 9 ft 4 in |
| Overall width                | 2 ft 5 in              | 2 ft 5 in  | 2 ft 5 in             |
| Overall length (D)           | 4 ft 2 in              | 4 ft 4 in  | 4 ft 4 in             |
| Stowed height (E)            | 6 ft 6 in              | 8 ft 3 in  | 9 ft 6 in             |
| Tilt back length (F)         | 8 ft 6 in              | 8 ft 8 in  | 9 ft 10 in            |
| Tilt back height (G)         | 6 ft 5 in              | 6 ft 5 in  | 6 ft 7 in             |

| PERFORMANCE  |  |               |               |
|--|--|---------------|---------------|
| Platform capacity (SWL)                                  | 350 lbs                                | 300 lbs       | 300 lbs       |
| Max. wind speed  | 0 mph                                  | 0mph          | 0mph          |
| Raise/lower time   | 43/23 seconds                          | 57/26 seconds | 60/40 seconds |
| Wheels   | 9 in x 2.5 in rear, 6 in casters front |               |               |
| Controls   | push button                            |               |               |
| Wall access<br>(Distance from front of platform to wall) | 14 in                                  | 14 in         | 29 in         |

| POWER             |                       |  |  |
|-------------------|-----------------------|--|--|
| Power source (AC) | 120/220V AC 50HZ      |  |  |
| Power source (DC) | 1 x 12V 105Ah battery |  |  |

| WEIGHT      |         |           |           |
|-------------|---------|-----------|-----------|
| Weight (AC) | 859 lbs | 959 lbs   | 1,036 lbs |
| Weight (DC) | 926 lbs | 1,025 lbs | 1,102 lbs |

## STABILIZER FOOTPRINT

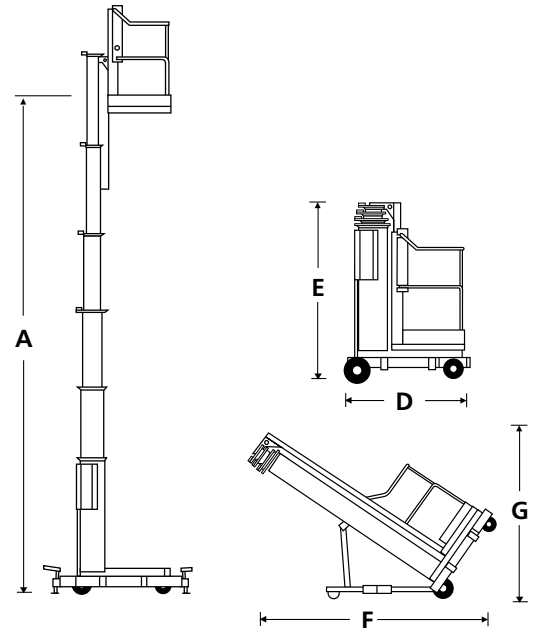
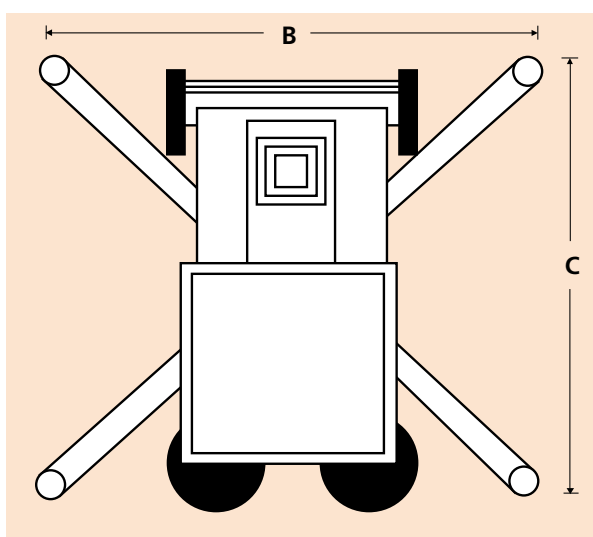

## STANDARD FEATURES

- Patented Girder Lock telescopic mast system
- Integrated tilt-back system
- Ground level entry
- EZ loader system for transport
- Outrigger interlock indicators
- Integrated battery charger (DC only)
- Non-marking wheels & casters
- 2 year parts and labor, 5 year structural warranty
- ANSI compliant

## OPTIONS

- Special paint colors
- Tool tray
- Environmental hydraulic oil
- Laser locator
- CSA compliant

**snorkel** [www.snorkellifts.com](http://www.snorkellifts.com)

P.O. Box 1160  
 St. Joseph, MO 64502-1160, USA  
 Tel: 1 (785) 989-3000  
 Toll-free: 1 (800) 255-0317  
 Fax: 1 (785) 989-3070  
 Email: sales.usa@snorkellifts.com