

Powerful, maintenance-free 3-phase AC technology

Electronically-controlled lift motor for precise lifting and lowering

Shock-absorbing platform with side arms (optional)

Comfortable steering with electrical tiller and curveCONTROL

Flexible design with fork-over or straddle baseleg options to suit virtually every application



ERC 212 / 214 / 216 / 220 **ERC 212b / 214b / 216b / 220b**

Fork-over and straddle stand-on stacker (2,600 - 4,400 lbs.)

The efficient and versatile Jungheinrich® ERC and ERC b electric stackers are particularly well-suited for the economic transport of goods over medium to long distances. They are also ideal for stacking and retrieval operations on higher racking levels up to 19.7'. With a foldable stand-on platform, optional support arm lift and both fork-over and straddle version design, these trucks provide excellent flexibility.

The ERC's and ERC b's ground clearance allows them to effectively travel over ramps or uneven surfaces. The additional support arm lift (optional) allows for the transport of two pallets simultaneously, further increasing productivity and operational throughput.

With fork-over and straddle baseleg options available, customers can handle both Euro pallets and Grocery Manufacturers Association (GMA) pallets effectively and efficiently. The robust and precise lift motor allows for gentle lifting and lowering of loads.

*The product shown may be different than the actual configuration based on market requirements.

**JUNGHEINRICH®**

Technical data

Characteristics				Jungheinrich		Jungheinrich		Jungheinrich		Jungheinrich	
				ERC 212		ERC 212b		ERC 214		ERC 214b	
1.1	Manufacturer			Jungheinrich		Jungheinrich		Jungheinrich		Jungheinrich	
1.2	Model			ERC 212		ERC 212b		ERC 214		ERC 214b	
1.3	Drive			electric		electric		electric		electric	
1.4	Type of operation			pedestrian / ride-on		pedestrian / ride-on		pedestrian / ride-on		pedestrian / ride-on	
1.5	Load capacity / rated load	Q	lb kg	2,600	1,200	2,600	1,200	3,000	1,400	3,000	1,400
1.6	Load center distance	c	in mm	24	600	24	600	24	600	24	600
1.8	Load distance, center of drive axle to fork	x	in mm	37.1	688	37.1	688	26.3	667	26.3	668
1.9	Wheelbase	y	in mm	49.8	1,264	52.7	1,339	49.8	1,264	55.6	1,411
Weights	2.1 Service weight (including battery)			lb kg	2,491 1,130	2,579 1,170	2,579 1,170	2,646 1,200	2,646 1,200	2,679 1,215	2,679 1,215
	2.2 Axle load – with load, front / rear			lb kg	1,962 / 3,175 890 / 1,440	1,984 / 3,241 900 / 1,470	1,984 / 3,241 900 / 1,470	2,116 / 3,616 960 / 1,640	2,116 / 3,616 960 / 1,640	2,028 / 3,814 920 / 1,730	2,028 / 3,814 920 / 1,730
	2.3 Axle load – unloaded, front / rear			lb kg	1,830 / 661 830 / 300	1,830 / 750 830 / 340	1,830 / 750 830 / 340	1,940 / 705 880 / 320	1,940 / 705 880 / 320	1,874 / 882 850 / 400	1,874 / 882 850 / 400
Wheels, Chassis	3.1 Tires			Vulkollan		Vulkollan		Vulkollan		Vulkollan	
	3.2 Tire size, front			Ø 230 x 77		Ø 230 x 77		Ø 230 x 77		Ø 230 x 77	
	3.3 Tire size, rear			Ø 85 x 110 / 85		Ø 85 x 75		Ø 85 x 110 / 85		Ø 85 x 75	
	3.4 Additional wheels (dimensions)			Ø 140 x 54		Ø 140 x 54		Ø 140 x 54		Ø 140 x 54	
	3.5 Wheels – number, front / rear (x=driven)			1x +1/2		1x +1/4		1x +1/2		1x +1/4	
	3.6 Tread width, front			b ₁₀ in mm	20.3 515	20.3 515	20.3 515	20.3 515	20.3 515	20.3 515	20.3 515
	3.7 Tread width, rear			b ₁₁ in mm	15.7 400	39.4 1,000	39.4 1,000	15.7 400	15.7 400	39.4 1,000	39.4 1,000
Dimensions	4.2 Mast height (lowered)			h ₁ in mm	76.8 1,950	76.8 1,950	76.8 1,950	76.8 1,950	76.8 1,950	76.8 1,950	76.8 1,950
	4.3 Free lift			h ₂ in mm	3.9 100	3.9 100	3.9 100	3.9 100	3.9 100	3.9 100	3.9 100
	4.4 Maximum fork height			h ₃ in mm	185 4,699	185 4,699	185 4,699	236 5,994	236 5,994	211 5,359	211 5,359
	4.5 Extended mast height			h ₄ in mm	132.9 3,375	136.6 3,470	136.6 3,470	132.9 3,375	132.9 3,375	136.6 3,470	136.6 3,470
	4.9 Height of tiller in drive position – minimum / maximum			h ₁₄ in mm	46.1 / 54.7 1,170 / 1,390	46.1 / 54.7 1,170 / 1,390	46.1 / 54.7 1,170 / 1,390	46.1 / 54.7 1,170 / 1,390	46.1 / 54.7 1,170 / 1,390	46.1 / 54.7 1,170 / 1,390	46.1 / 54.7 1,170 / 1,390
	4.19 Overall length			l ₁ in mm	77.0 1,955	79.9 2,030	79.9 2,030	77.8 1,976	77.8 1,976	79.9 2,123	79.9 2,123
	4.20 Length – including fork shank			l ₂ in mm	31.7 805	34.6 880	34.6 880	32.5 826	32.5 826	38.3 973	38.3 973
	4.21 Overall width			b ₁ / b ₂ in mm	31.5 800	43.3 1,100	43.3 1,100	31.5 800	31.5 800	43.3 1,100	43.3 1,100
	4.22 Fork dimensions, thickness / width / length			in mm	2.2 / 7.3 56 / 185 45.2 1,150	1.5 / 3.9 40 / 100 45.3 1,150	1.5 / 3.9 40 / 100 45.3 1,150	2.2 / 7.3 56 / 185 45.2 1,150	2.2 / 7.3 56 / 185 45.2 1,150	1.5 / 3.9 40 / 100 45.3 1,150	1.5 / 3.9 40 / 100 45.3 1,150
	4.25 Width across forks			b ₅ in mm	22.4 570	31.5 800	31.5 800	22.4 570	22.4 570	31.5 800	31.5 800
	4.32 Ground clearance, center wheelbase			m ₂ in mm	1.1 28	2.0 50	2.0 50	1.1 28	1.1 28	2.0 50	2.0 50
	4.33 Aisle width for pallets 39.4" x 47.2" sideways			Ast in mm	85.4 2,170	88.7 2,252	88.7 2,252	86.3 2,191	86.3 2,191	91.4 2,322	91.4 2,322
	4.34 Aisle width for pallets 31.5" x 47.2" lengthways			Ast in mm	87.4 2,220	90.6 2,302	90.6 2,302	88.2 2,241	88.2 2,241	93.4 2,372	93.4 2,372
4.35 Turning radius			Wa in mm	59.4 1,508	61.8 1,570	61.8 1,570	59.4 1,508	59.4 1,508	64.6 1,640	64.6 1,640	
Performance	5.1 Travel speed, with / without load			mph km/h	5.6 / 6.8 9 / 11	5.6 / 6.8 9 / 11	5.6 / 6.8 9 / 11	5.6 / 6.8 9 / 11	5.6 / 6.8 9 / 11	5.6 / 6.8 9 / 11	5.6 / 6.8 9 / 11
	5.2 Lift speed, with / without load			f/m m/s	31.5 / 78.7 0.2 / 0.4	31.5 / 78.7 0.2 / 0.4	31.5 / 78.7 0.2 / 0.4	39.4 / 59.1 0.2 / 0.3	39.4 / 59.1 0.2 / 0.3	39.4 / 59.1 0.2 / 0.3	39.4 / 59.1 0.2 / 0.3
	5.3 Lower speed, with / without load			f/m m/s	88.6 / 68.9 0.45 / 0.35	88.6 / 68.9 0.45 / 0.35	88.6 / 68.9 0.45 / 0.35	88.6 / 68.9 0.45 / 0.35	88.6 / 68.9 0.45 / 0.35	88.6 / 68.9 0.45 / 0.35	88.6 / 68.9 0.45 / 0.35
	5.8 Maximum gradeability, with / without load			%	10 / 20	10 / 20	10 / 20	10 / 20	10 / 20	10 / 20	10 / 20
	5.10 Service brake				generative	generative	generative	generative	generative	generative	generative
Electrical	6.1 Drive motor, rating S ₂ 60 minutes			kW	2.8	2.8	2.8	2.8	2.8	2.8	2.8
	6.2 Lift motor, output with S ₃			kW	3	3	3	3	3	3	3
	6.3 Battery according to DIN 43531/35/36				DIN 43535 B	DIN 43535 B	DIN 43535 B	DIN 43535 B	DIN 43535 B	DIN 43535 B	DIN 43535 B
	6.4 Battery voltage / nominal capacity			k _s V Ah	24 / 300	24 / 300	24 / 300	24 / 300	24 / 300	24 / 375	24 / 375
	6.5 Battery weight			lb kg	525 238	525 238	525 238	525 238	525 238	601 273	601 273
	6.6.1 Energy consumption according to EN cycle			kWh/h	0.64	0.64	0.64	0.76	0.76	0.74	0.74
	6.6.2 CO ₂ equivalent as per EN 16796			lb/h kg/h	0.77 0.35	0.77 0.35	0.77 0.35	0.90 0.41	0.90 0.41	0.88 0.40	0.88 0.40
	6.7 Throughput efficiency			t/h	57	57	57	65	65	65	65
	6.8 Energy consumption with maximum throughput			kWh/h	1.65	1.65	1.65	1.64	1.64	1.64	1.64
Other	8.1 Type of drive control				AC speedCONTROL	AC speedCONTROL	AC speedCONTROL	AC speedCONTROL	AC speedCONTROL	AC speedCONTROL	AC speedCONTROL
	8.4 Sound level at driver's ear according to EN 12053			dB(A)	64	64	64	64	64	64	64

- 1) Diagonal in accordance with VDI: + 5.4 in (138 mm)
- 2) Diagonal in accordance with VDI: + 8.5 in (215 mm)
- 3) DZ: x - 1.7 in (42 mm); l₁ + 1.7 in (42 mm); l₂ + 1.7 in (42 mm)
- 4) Other speed versions: 3.6 / 3.6 mph (6.0/6.0 km/h) (standard), and 4.4 / 4.4 mph (7.0/7.0 km/h)
- 5) Tandem Ø 3.3 x 3.3 in (85 x 85 mm)

In accordance with VDI Guideline 2198 this specification sheet provides details of the standard truck only. Non-standard tires, different masts, optional equipment, etc. may result in different values.

ERC 212/214/216 data of battery compartment M-VBE; hoist frame ZT2800/2900; equipment: drivePLUS - 1.8: For DZ-mast: x - 42 mm - 3.3: Tandem: Ø85 x 85 mm - 4.19: For DZ-mast: l₁ + 42 mm; for battery compartment L-VBE or L-SBE: l₁ + 72 mm - 4.20: For DZ-mast: l₂ + 42 mm; for battery compartment L-VBE or L-SBE: l₂ + 72 mm - 4.33: Diagonal as per VDI: Ast + 215 mm; for battery compartment L-VBE or L-SBE: Ast + 72 mm - 4.34: Diagonal as per VDI: Ast + 138 mm; for battery compartment L-VBE or L-SBE: Ast + 72 mm - 5.1: For equipment Efficiency without restraint system: 6.0/6.0 km/h; with restraint system: 7.0/7.0 km/h - 5.8: For equipment Efficiency: ERC 212: 10/16 %; ERC 214: 09/16 %; ERC 216: 08/16 % - 6.6: For equipment Efficiency: ERC 212: 0.63 kWh/h; ERC 214: 0.81 kWh/h; ERC 216: 0.86 kWh/h - 6.7: For equipment Efficiency: ERC 212: 56 t/h; ERC 214: 64 t/h; ERC 216: 71 t/h - 6.8: For equipment Efficiency: ERC 212: 1.63 kWh/h; ERC 214: 1.65 kWh/h; ERC 216: 1.67 kWh/h

This specification sheet only provides technical values for the standard truck. Non-standard tires, different masts, additional equipment, etc., could produce other values. Rights reserved for technical changes and improvements.

Jungheinrich ERC 216 electric		Jungheinrich ERC 216b electric		Jungheinrich ERC 220 electric		Jungheinrich ERC 220b electric	
pedestrian / ride-on		pedestrian / ride-on		pedestrian / ride-on		pedestrian / ride-on	
3,500	1,600	3,500	1,600	4,400	2,000	4,400	2,000
24	600	24	600	24	600	24	600
26.3	667	26.3	668	27.0	687	26.3	668
49.8	1,264	55.6	1,411	52.6	1,336	55.6	1,411
2,690	1,220	2,756	1,250	2,901	1,316	2,901	1,316
2,161 / 4,057	980 / 1,840	2,028 / 4,255	920 / 1,930	2,167 / 5,141	983 / 2,332	2,167 / 5,141	983 / 2,332
1,962 / 728	890 / 330	1,874 / 882	850 / 400	2,037 / 864	924 / 392	2,037 / 864	924 / 392
Vulkollan Ø 230 x 77		Vulkollan Ø 230 x 77		Vulkollan Ø 230 x 77		Vulkollan Ø 230 x 77	
Ø 85 x 110 / 85		Ø 85 x 75		Ø 85 x 85		Ø 85 x 75	
Ø 140 x 54		Ø 140 x 54		Ø 140 x 54		Ø 140 x 54	
1x +1/2		1x +1/4		1x +1/4		1x +1/4	
20.3	515	20.3	515	20.3	515	20.3	515
15.7	400	39.4	1,000	15.7	400	39.4	1,000
76.8	1,950	76.8	1,950	82.7	2,100	82.7	2,100
3.9	100	3.9	100	3.9	100	3.9	100
207	5,245	207	5,245	139	3,531	139	3,531
130.9	3,325	136.6	3,370	136.4	3,465	136.4	3,465
46.1 / 54.7	1,170 / 1,390	46.1 / 54.7	1,170 / 1,390	46.1 / 54.7	1,170 / 1,390	46.1 / 54.7	1,170 / 1,390
77.8	1,976	79.9	2,123	80.6	2,048	79.9	2,123
32.5	826	38.3	973	35.4	898	38.3	973
31.5	800	43.3	1,100	31.5	800	43.3	1,100
2.2 / 7.3 / 45.2	56 / 185 / 1,150	1.6 / 3.9 / 45.3	40 / 100 / 1,150	2.2 / 7.3 / 45.2	56 / 185 / 1,150	2.0 / 5.5 / 45.3	50 / 140 / 1,150
22.4	570	31.5	800	22.4	570	31.5	800
1.1	28	2.0	50	0.7	18	1.5	40
86.3	2,191	91.4	2,322	89.1	2,263	91.4	2,322
88.2	2,241	93.4	2,372	91.1	2,313	93.4	2,372
62.2	1,508	64.6	1,640	62.2	1,580	64.6	1,640
5.6 / 6.8	9 / 11	5.6 / 6.8	9 / 11	5.0 / 6.2	8 / 10	5.0 / 6.8	8 / 11
31.5 / 59.1	0.2 / 0.3	31.5 / 59.1	0.2 / 0.3	19.7 / 35.4	0.1 / 0.2	19.7 / 35.4	0.1 / 0.2
88.6 / 68.9	0.45 / 0.35	88.6 / 68.9	0.45 / 0.35	88.6 / 68.9	0.45 / 0.35	88.6 / 68.9	0.45 / 0.35
10 / 20		10 / 20		6 / 16		6 / 20	
generative		generative		generative		generative	
2.8		2.8		2.8		2.8	
3		3		3		3	
DIN 43535 B		DIN 43535 B		DIN 43535 B		DIN 43535 B	
24 / 300		24 / 375		24 / 375		24 / 375	
525	238	601	273	635	288	635	288
0.83		0.83		—		—	
0.99	0.45	0.99	0.45	—		—	
73		73		—		—	
1.65		1.65		—		—	
AC speedCONTROL		AC speedCONTROL		AC speedCONTROL		AC speedCONTROL	
64		64		64		64	

ERC 212/214/216/220

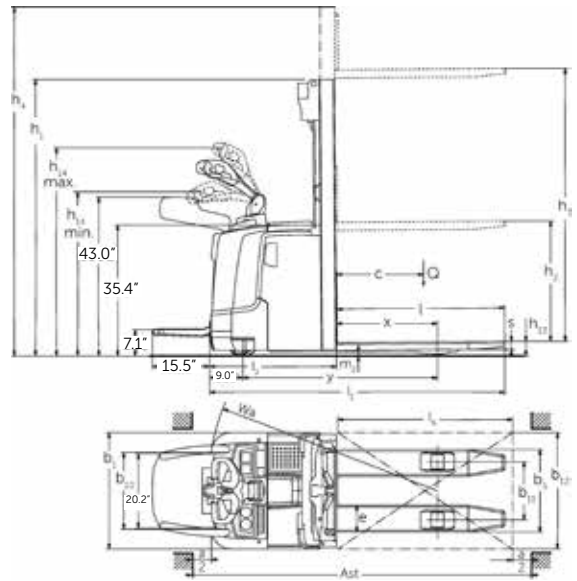

The Jungheinrich Advantage



ERC storage controls and compartment



ERC operator position



Easy-to-operate main connector for on-board charger

'Intelligent' control and advanced drive technology

The ERC and ERC b series are equipped with a modern 3-phase AC drive motor, offering you greater performance while simultaneously reducing operating costs. Advantages:

- High lever of efficiency with excellent energy management
- Powerful acceleration
- Rapid direction change
- Jungheinrich speedCONTROL – different efficiency modes for different performance levels
- No carbon brushes – maintenance-free drive motor
- Increased drive speed and acceleration with drivePLUS and load-dependent driving behavior

Flexible operation

Fork-over and straddle designs available for Euro pallets and GMA pallets respectively. Different models for a whole range of applications. Stand-on platform and side arms can be folded in for use in confined applications.

Version 1:

- 3.7 mph stand-on platform without side-arms

Version 2:

- 4.3 mph (ERC) / 5.6 mph (ERC b except 220b) stand-on platform with side-arms & fixed support wheel

Version 3:

- 6.8 mph stand-on platform with side arms & hydraulic support wheel (except 220 & 220b)

Easy stacking and retrieval

- Intuitive control of all lifting and lowering functions with multifunction tiller head
- Precise and gentle lifting / lowering of loads with speed-controlled hydraulic motor
- Four-wheel concept for excellent load stability

Comfortable and intuitive operation

- The electric tiller steering is precise and allows for easy steering and fatigue-free operation, even in confined spaces. curveCONTROL monitors steer angle and automatically reduces the speed of the truck when cornering
- The shock-absorbing stand-on platform accommodates uneven surfaces, effectively reducing strain on the operator
- Padded side arms (optional) help ensure a comfortable posture when cornering
- The low platform height helps ensure easy entry / exit

Long run times / up time

- Side battery extraction option for multi-shift applications
- Integrated, on-board charger (110/120V-30A) for wet-cell batteries and maintenance-free batteries for easy charging at any 230V main socket (optional)

Robust and productive design

The ERC and ERC b are designed for highly productive applications:

- 0.31" steel chassis
- Enclosed chassis
- Robust mast with high residual capacities
- Additional lift mechanism to raise the support arm lift independently of the forks
- Double-decker transport of 2 pallets simultaneously (optional)

Additional equipment

- Load guard
- Full or half option bar for additional equipment
- Shorter battery compartment from previous generation for better maneuverability
- US chargers
- easyACCESS softkey (2-inch color display)
- Speed display, load display, battery residual time display
- Floor spots, mirrors, additional storage space, etc.

Additional features

- Touch Mode enables order picking without getting on/ off the truck
- Gentle lowering of loads
- Cold store version
- Load backrest options
- Tandem load wheels
- Integrated weighing system
- Power saving functionality
- Lighting/reflector awareness options

Parts when you need them

Jungheinrich's Parts Fast or Parts Free Guarantee ensures next-business-day delivery by 5:00 PM of all Jungheinrich parts in the United States, or they're free, including freight. For customers in Canada and Mexico, the guarantee ensures shipping of parts within 24 hours from the time the order was placed by the dealer. See your local Jungheinrich dealer for program details.

* Programs may be subject to change without notice and may vary by region. Please ask your local Jungheinrich dealer for complete terms and conditions.

**The product shown may be different than the actual configuration based on market requirements.