



ELECTRIC CUSHION TIRE FORKLIFT

3,000-4,000 LB CAPACITY

THE POWER AND EFFICIENCY YOUR BUSINESS NEEDS



COMFORT COMES STANDARD.

STEP INTO THE OPERATOR COMPARTMENT OF AN FBC15N-FBC18LN ELECTRIC FORKLIFT



Spacious Operator Compartment:

From the beginning of the shift to the end, the FBC series electric forklift was designed for optimal comfort. Operators can easily adjust the seat in different ways according to their preferences and have a comfortable ride the entire shift. The narrow steering wheel column design also provides extra space and comfort.

Ergonomic Hydraulic Levers:

Mounted on the dashboard, the hydraulic levers allow the operator to reach the levers in a natural, relaxed position while working.

Convenience On The Go:

An ample storage compartment and optional USB charging port keeps the extra tools they need charged and close at hand.

Redesigned For Reliability And Functionality:

The FBC series is focused on efficiency. It features new controllers to improve energy efficiency and easy to remove panels to allow for easier maintenance. The 4-inch full color display and foot operated parking brake allow for increased productivity during the workday.

- Designed for superior comfort
- Adjustable seating to suit your operators
- Optimized visibility

All come together to create a comfortable forklift you can count on.





Features	Standard	Optional
Multifunction color display	●	
Fully-hydrostatic steer axle	●	
AC motor control system	●	
Regenerative braking system	●	
5 default performance modes	●	
LED forward working lights	●	
Integrated Presence System (IPS)	●	
Full-suspension seat		●
Emergency battery disconnect button	●	



Ask your local dealer about the available options for improved performance, productivity and operator comfort.

POWERFUL EFFICIENCY.

LONGER RUNTIMES AND LESS MAINTENANCE ADD UP TO A BETTER BOTTOM LINE.



Rock-Solid Frame: The all welded box frame and battery edge cover design helps to extend the life of your investment.

Run Longer: On One Battery Charge.

Thanks to the design of the FBC15N-FBC18LN models your operators can deliver the productivity you need to get the job done.

Key Features:

- Advanced AC motors
- Optimized regenerative braking system

Lower Energy Consumption: The two-stage hydraulic system determines the optimum motor speed, resulting in reduced energy consumption and longer run times.





Easy To Service

Easily removable floor and rear access panels, make accessing the motors and major components simple, saving you time and money.

- 500-hour extended service intervals
- Display-based maintenance reminders
- Tool-free access to key service components

With our planned maintenance (PM) program, your local dealer will evaluate your operation to develop a maintenance schedule tailored to your business.



Smart Systems And Options For The Way You Work

Integrated Presence System (IPS)

This integrated, computer-based feedback system uses both audible and visual indicators to alert the operator to potentially hazardous situations, while increasing operator awareness.

Flexible Options

- **Foot directional control**, for hands-free forward and reverse travel control. Ideal for rapid shuttle applications.
- **Sideshifter** for more precise load handling.
- **Lower height overhead guard option** is available to accommodate taller operators, low clearances or special storage racking configurations.

UL ES or EE Ratings are available for applications requiring added protection from potential fire or electrical shock risks.

CHARACTERISTICS			FBC15N		FBC18N		FBC18LN	
1	Capacity at rated load center	lb kg	3,000	1,500	3,500	1,800	4,000	1,800
2	Capacity at load center – distance	in mm	24	500	24	500	24	600
3	Power – diesel, gasoline, LP gas, electric		Electric		Electric		Electric	
4	Tire type – cushion, solid pneumatic		Cushion		Cushion		Cushion	
5	Wheels, number front / rear (x = driven)		2x / 2		2x / 2		2x / 2	
DIMENSIONS								
6	Maximum fork height	in mm	130.7	3,320	130.7	3,320	130.7	3,320
7	Free lift	in mm	4.5	115	4.5	115	4.5	115
8	Fork dimensions – thickness x length x width	in mm	1.4x42x3.9	35x1,070x100	1.4x42x3.9	35x1,070x100	1.4x42x3.9	35x1,070x100
9	Fork spacing – out-to-out minimum / maximum	in mm	9.4 / 32	240 / 818	9.4 / 32	240 / 818	9.4 / 32	240 / 818
10	Tilt forward / backward	deg°	5.0 / 6.0°		5.0 / 6.0°		5.0 / 6.0°	
11	Overall length (with 42" forks)	in mm	120.0	3,050	120.0	3,050	123.0	3,125
12	Length to fork face (includes fork thickness)	in mm	78.0	1,980	78.0	1,980	81.0	2,055
13	Overall width with single drive tires	in mm	37.0	947	37.0	947	39.0	995
14	Overall width with wide stance tires	in mm	39.0	996	39.0	996	41.0	1,045
15	Height to top of lowered mast	in mm	83.1	2,110	83.1	2,110	83.1	2,110
16	Seat height to SIP	in mm	40.3	1,023	40.3	1,023	40.3	1,023
17	Height to top of overhead guard	in mm	86.0	2,180	86.0	2,180	86.0	2,180
18	Height of drawbar pin	in mm	9.2	234	9.2	234	9.2	234
19	Height with mast raised	in mm	179.2	4,550	179.2	4,550	179.2	4,550
20	Minimum outside turning radius	in mm	70.5	1,790	70.5	1,790	72.5	1,840
21	Load distance, axle to fork face (load moment constant)	in mm	14.8	376	14.8	376	14.8	376
22	Minimum aisle – 90° stack – zero clearance without load	in mm	85.0	2,165	85.0	2,165	87.5	2,220
PERFORMANCE								
23	Travel speed, loaded / empty (36 volt)	mph km/h	10.2 / 11.2	16.4 / 18.0	9.3 / 10.8	14.9 / 17.3	9.3 / 10.8	14.9 / 17.3
24	Travel speed, loaded / empty (48 volt)	mph km/h	11.3 / 11.3	18.2 / 18.2	11.3 / 11.3	18.2 / 18.2	11.3 / 11.3	18.2 / 18.2
25	Lift speed, loaded / empty (36 volt)	fpm mm/s	78.7 / 110.2	0.40 / 0.56	74.8 / 110.2	0.38 / 0.56	70.9 / 110.2	0.36 / 0.56
26	Lift speed, loaded / empty (48 volt)	fpm m/s	98.4 / 129.9	0.50 / 0.66	94.5 / 129.9	0.48 / 0.66	90.6 / 129.9	0.46 / 0.66
27	Lowering speed, loaded / empty	fpm m/s	98.4 / 80.7	0.50 / 0.41	98.4 / 80.7	0.50 / 0.41	98.4 / 80.7	0.50 / 0.41
28	Gradeability loaded at 1 mph (1.6 km) (36 volt)	%	24		21		21	
29	Gradeability loaded at 1 mph (1.6 km) (48 volt)	%	25		22		22	
30	Gradeability maximum, loaded / empty	%	15 / 23		15 / 19		15 / 18	
WEIGHT								
31	Empty with minimum weight battery	lb kg	6,270	2,845	6,790	3,085	7,370	3,345
32	Axle load with rated load, front / rear	lb kg	8,030 / 1,240	3,750 / 595	8,770 / 1,520	4,200 / 685	9,445 / 1,925	4,250 / 895
33	Axle load without load, front / rear	lb kg	2,500 / 3,770	1,125 / 1,720	2,320 / 4,470	1,050 / 2,035	2,070 / 5,300	950 / 2,395
CHASSIS								
34	Tire size – front (standard duals)	in mm	18.0x6.0x12.2	457x152x308	18.0x6.0x12.2	457x152x308	18.0x7.0x12.2	457x178x308
35	Tire size – rear	in mm	14.0x5.0x10.0	356x127x254	14.0x5.0x10.0	356x127x254	14.0x5.0x10.0	356x127x254
36	Wheelbase	in mm	46.0	1,170	46.0	1,170	46.0	1,170
37	Track width – front (standard tires)	in mm	31.0	793	31.0	793	32.0	818
38	Track width – rear	in mm	32.3	820	32.3	820	32.3	820
39	Ground clearance at lowest point of mast	in mm	3.0	75.0	3.0	75.0	3.0	75.0
40	Ground clearance at center of wheelbase	in mm	3.9	100	3.9	100	3.9	100
41	Service brakes	type	foot-operated, hydraulic		foot-operated, hydraulic		foot-operated, hydraulic	
42	Parking brakes	type	foot-operated, mechanical		foot-operated, mechanical		foot-operated, mechanical	
ELECTRICAL								
43	Battery type		lead-acid		lead-acid		lead-acid	
44	Battery capacity at 6 hr. discharge rate (36 volt)	Ah kWh	880	31.7	880	31.7	880	31.7
45	Battery capacity at 6 hr. discharge rate (48 volt)	Ah kWh	770	37.0	770	37.0	770	37.0
46	Battery weight, minimum	lb kg	1,650	750	1,650	750	1,650	750
47	Battery weight, maximum	lb kg	2,650	1,200	2,650	1,200	2,650	1,200
48	Battery compartment size, maximum	in mm	27.8x35.8x23.3	708x906x592	27.8x35.8x23.3	708x906x592	27.8x35.8x23.3	708x906x592
49	Drive motor capacity (60 min. rating) 36v / 48v	HP kW	8.3 / 9.1	6.2 / 6.8	8.3 / 9.1	6.2 / 6.8	8.3 / 9.1	6.2 / 6.8
50	Lift output (15% rating) 36v / 48v	HP kW	15.4	11.5	15.4	11.5	15.4	11.5
51	Drive controls /hydraulic controls	type	AC transistor		AC transistor		AC transistor	
52	Relief pressure for attachments	PSI Mpa	2,277	15.7	2,277	15.7	2,277	15.7
53	Flow rate for attachments	gpm lpm	14.5	55	14.5	55	14.5	55

NOTE: These specifications assume the use of drive axles, tires and tilt angles specified. Maximum converted value to gradeability at maximum torque of the traction motor. Any modification to specifications, or any other combination of specifications made after the shipment of the truck, requires prior written approval from Mitsubishi Caterpillar Forklift America Inc. (MCFA). (See ANSI/ITSDF B56.1.) Also be advised that overall operating visibility may be affected by the mast configuration and mast options of your truck. Therefore, you may need to add ancillary [auxiliary] devices or modify your operating practices. Consult your dealer for further information.

Call-out numbers shown in the diagram below correspond to the first column of the specifications chart.

FBC15N- FBC18LN

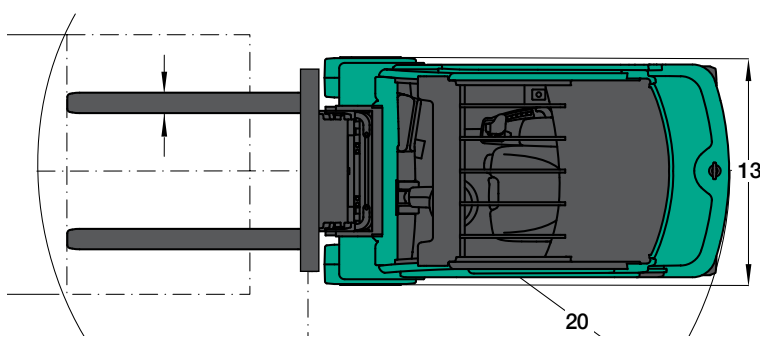
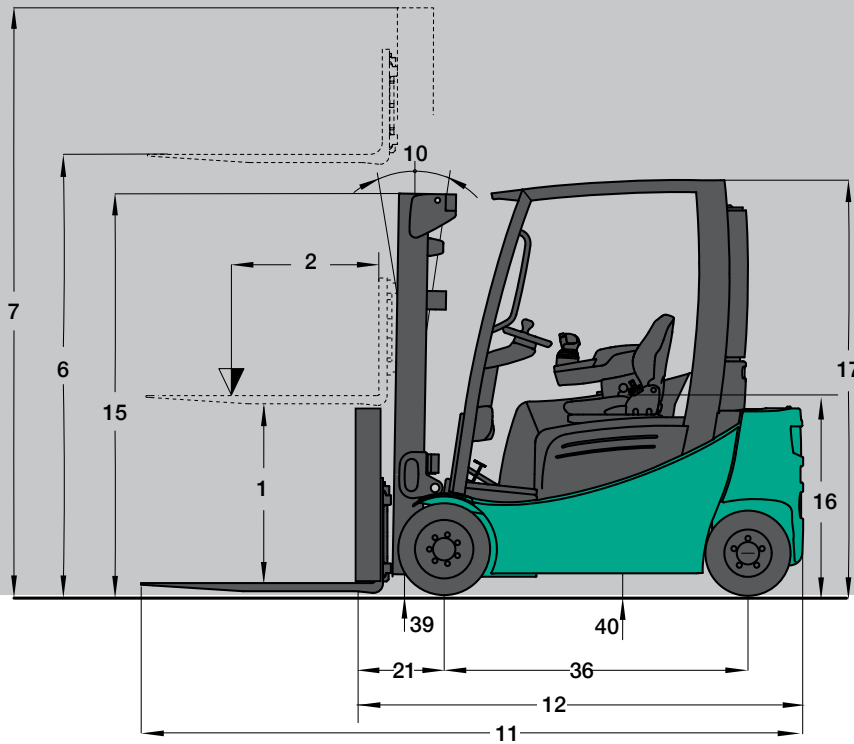

SAFETY STANDARDS

These trucks meet American National Standards Institute/Industrial Truck Standards Development Foundation, ANSI/ITSDF B56.1. UL-Classified by Underwriters Laboratories, Inc., as to fire and electric shock hazard only; Type E, EE (optional), Industrial Trucks. Users should be aware of, and adhere to, applicable codes and regulations regarding operator training, use, operation and maintenance of powered industrial trucks, including:

- ANSI/ITSDF B56.1.
- NFPA 505, fire safety standard for powered industrial trucks -type designations, areas of use, maintenance and operation.
- Occupational Safety and Health Administration (OSHA) regulations that may apply.

Specifications, equipment, technical data, photos and illustrations based on information at time of printing and subject to change without notice. Some products may be shown with optional equipment.

FBC15N-FBC18LN

3,000-4,000 LB CAPACITY ELECTRIC CUSHION TIRE FORKLIFT

Delivering Exceptional Value

More Than 296,000 Parts To Keep You Running

Mitsubishi Forklift Trucks offers several parts programs, all designed to bring you top performance and convenience for your material handling needs. Contact your local dealer to put our services to work for you.

Support To Fit Your Operation

Find out why more companies are relying on Mitsubishi forklift truck dealers to keep their fleet operating at top performance. Our efficiency provides customers with a better return on investment, and qualified service technicians, diverse parts inventory and unparalleled selection of service options can help reduce your total cost of ownership.

Extensive Dealer Network

The Mitsubishi forklift truck dealer network is dedicated to finding the right forklift solution for your business. With more than 300 dealer locations, you can rely on your local dealer to provide the service you need when you need it most.



Manufactured with superior quality and exceptional value, Mitsubishi forklift trucks are supported by an extensive dealer and field support network located throughout North and South America. Don't forget to ask your local Mitsubishi forklift truck dealer about details on factory retail programs, financing plans and additional options and dealer services like planned maintenance and operator training.