



CLASSIC II

— NO BODY BETTER —



STEEL & ALUMINUM SERVICE BODIES

MADE FOR MORE



A product of the USA



SERVICE BODIES

We introduced the concept of service and utility truck bodies to the construction industry over 60 years ago, and have never looked back. Our flagship Classic II service bodies keep tools, materials, parts and equipment organized for field service, installation and maintenance work of all types and for many miles down the road.

Aluminum Classic II
Steel Classic II



The Aluminum Service Body Leader

We created the first and most rugged aluminum service body over 35 years ago, and have been testing it on the job ever since. It's made for more payloads – and to withstand the harshest conditions and hardest work imaginable.

The difference is in the numbers:

- Industry-leading 10-year warranty
- Up to 10% fuel savings
- Up to 50% lighter than steel

INCREASED payload capacity

LESS WEAR and tear on chassis

INHERENTLY corrosion resistant

GREATER residual value at the end of life cycle

EASILY recycled



Aluminum or Steel **CLASSIC II**

STANDARD FEATURES

1 Hidden Hinges

Patented design resists forcible entry, and provides protection against corrosion without requiring frequent lubrication or maintenance. Fully adjustable and easily replaced without damage to body or door.

2 Frame-Mounted Bumper

Prevents body damage and provides a slip-resistant surface. Galvanized steel construction with an e-coat prime and white powder coat finish.

3 E-Coat Prime & Powder Coat Finish

Resistant to corrosion, chemicals, humidity, scratches, chips, and impact. E-Coat only applied to steel.

4 Slam Action Tailgate

Double-panel construction, stainless steel locking rods, hinge rods, striker channels, and a polished stainless steel handle.

5 Nitrogen Gas Door Struts

Controls opening and closing of all vertical compartment doors.



6 Exclusive Dual-Pro® Door Seal System

Automotive quality bubble-type seal and mechanical seals provide a dual line of defense against weather. Patented design increases clear door openings in every compartment.

7 Galvanized Shelves

Designed with 2" dividers for small item storage. Full access between horizontal and rear vertical compartment for longer tool storage.

8 Heavy-Duty Compartment Doors

Double-panel construction with internal reinforcement for added strength.

9 Stainless Steel Rotary Locks

Rust resistant with no exposed fasteners. Features a double-bitted, high quality locking cylinder, adjustable striker pins and an O-ring seal to prevent water intrusion.

10 LED Combination Lights

Bright, water-resistant lights with automotive grade sealed connectors, include stop, tail, turn and reverse.

Aluminum or Steel

CLASSIC II

Known for its premium construction, quality components, and innovative features, the Classic II is our premier service body. Whether you choose high strength aluminum or A60 galvanized steel, you're guaranteed a service body that meets the demands of your work, and stays on the road for the long haul.



POPULAR OPTIONS

All-Aluminum Construction

- Backed by an industry-leading 10 year warranty
- Up to 50% lighter than steel for increased payload capacity
- Corrosion-resistant
- Up to 10% more fuel efficient

Latch-Matic™ Keyless Entry

- One-touch locking and unlocking for all compartments
- Two key fob transmitters with 25' range
- Optional audible alarm is enabled by locking doors with the key fob transmitter
- Automotive quality components with concealed wiring and hardware
- Compartment doors can be locked individually with keys (provided)

LED Compartment Lighting

- Flex strip lighting and dome lights work in conjunction with the Latch-Matic system, activating lights when compartment doors are locked and unlocked
- Programmed to go off automatically after 10 minutes
- Impact resistant lenses
- Additional light for cargo bed also available

Spray-On Bedliner

- Available as a factory installed option
- Offers watertight and airtight truck bed protection
- Resists rust, corrosion and surface abrasion while providing a slip resistant surface

Master Locking

- Steel slide bar simultaneously locks all side compartment doors
- Spring loaded for easy manual operation



Aluminum or Steel **CLASSIC II**

The C2-60 Options Package

This Classic II can be equipped with the C2-60 package, a group of our most popular and most exclusive options.



Latch-Matic™ C2-60

Remote locking system with audible confirmation and security alarm also activates lighting.



Aluminum Treadplate

Protective guards on front of body panels and on top of tailgate.



LED Lighting

Compartment and cargo bed lighting activated by the security system.



Ergo Glide-N-Lock Drawers™

Modular compartment drawer system provides easy pull-out access to contents.

BUMPERS

Reading bumpers are constructed of heavy-duty A60 coating weight steel and are protected by E-Coat priming. They are offered in a wide array of styles and feature deck plate, poached, or all-weather slip resistant surfaces. Available only on certain models.

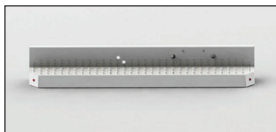

Single Wheel Bumper with LED lights



Dual Wheel Bumper with LED lights



Single Wheel Recessed Bumper with LED lights



Dual Wheel Recessed Bumper with LED Lights

STEEL EQUIPMENT RACKS

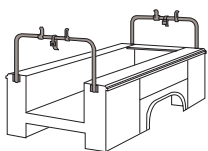

Removable Overhead Ladder Rack

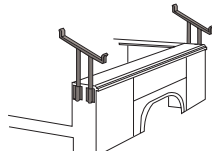

Removable Side Mount Ladder Rack (Angular Rack Shown, Flat Rack Also Available)

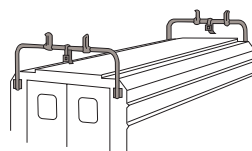

Removable Overhead Ladder Rack for Panel Body

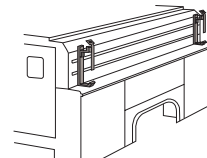

Side Mount Ladder Rack for Panel Body

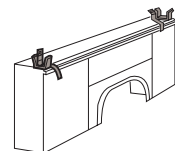

Pipe Vise Rack





CLASS-LEADING WARRANTIES

Your truck is the heart of your business. When it doesn't perform, you can't perform. That's why we back our work truck bodies with the best warranties in the business. To ensure that you get fast service when you need it, be sure to register your Reading truck body within 30 days of purchase and contact us anytime with any concerns you may have.



CLASSIC II MODEL

Standard Service Bodies

- Single and dual wheel configurations
- Available in 78", 82", 98", 108", and 132" sizes
- Protected by E-Coat priming and powder coat finish on steel models

Standard Service Body
108DW - "A" compartment layout shown

STANDARD BODIES

Model	Approx. Wt.		Cab-to-Axle	A	B	C	D	Approx. Compartment Clear Door Openings					J	K	L	M
	Steel	Alum.						E	F	G	H	I				
**78-SWs	882 lbs.	498 lbs.	40"	18"	42"	18"	78"	12-1/2" x 33-3/8"	40-1/2" x 11-7/8"	12-1/2" x 33-3/8"	56-1/2" x 11-7/8"	12-1/2" x 16-1/4"	11"	18-5/8"	24"	40"
*82-SWs	969 lbs.	522 lbs.	40"	17"	42"	23"	82"	11-1/2" x 33-3/8"	40-1/2" x 11-7/8"	17-1/2" x 33-3/8"	61-1/2" x 11-7/8"	17-1/2" x 16-1/4"	11"	18-5/8"	24"	40"
U98-SWs	1046 lbs.	600 lbs.	56"	28"	47"	23"	98"	22-1/2" x 33-3/8"	45-1/2" x 11-7/8"	17-1/2" x 33-3/8"	66-1/2" x 11-7/8"	17-1/2" x 16-1/4"	11"	18-5/8"	24"	40"
98-DWs	1164 lbs.	672 lbs.	56"	28"	47"	23"	98"	22-1/2" x 33-3/8"	45-1/2" x 11-7/8"	17-1/2" x 33-3/8"	66-1/2" x 11-7/8"	17-1/2" x 16-1/4"	11"	18-5/8"	24"	40"
U108-SWs	1158 lbs.	658 lbs.	60"	33"	47"	28"	108"	27-1/2" x 33-3/8"	45-1/2" x 11-7/8"	22-1/2" x 33-3/8"	71-1/2" x 11-7/8"	22-1/2" x 16-1/4"	11"	18-5/8"	24"	40"
U108-DW	1251 lbs.	730 lbs.	60"	33"	47"	28"	108"	27-1/2" x 33-3/8"	45-1/2" x 11-7/8"	22-1/2" x 33-3/8"	71-1/2" x 11-7/8"	22-1/2" x 16-1/4"	11"	18-5/8"	24"	40"

Installers Notes:

* 2017 Ford Super Duty chassis only | **E-Z mounting installation not available on these models
s Equipped with spring shackle offsets. Dimensions are 12 3/4" h x 4" deep.

STANDARD BODY DIAGRAMS

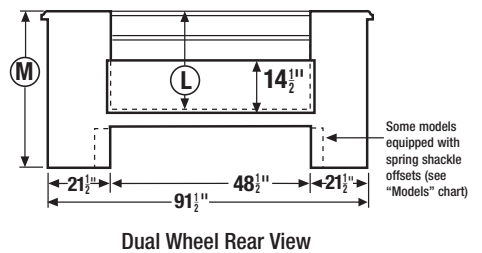
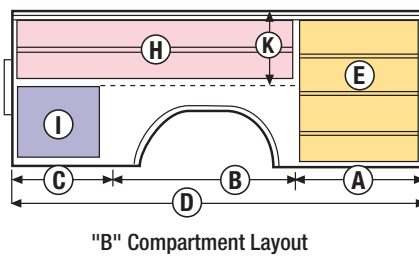
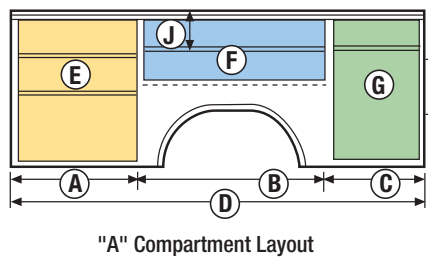
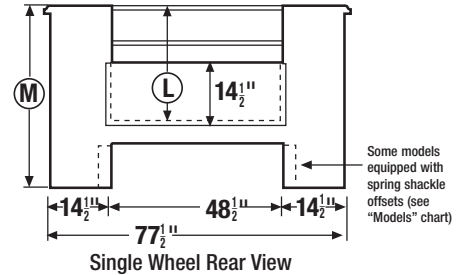
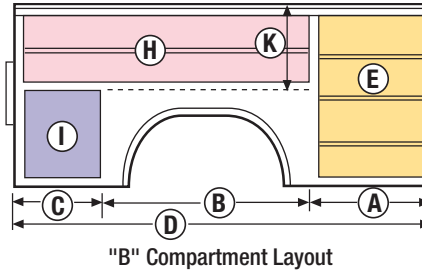
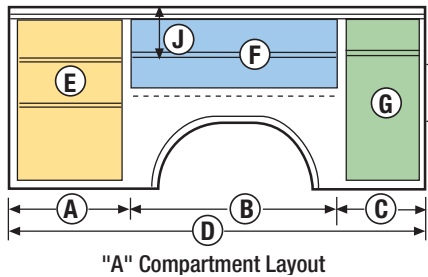

Standard Shelf and Divider Equipment

All shelves removable, all dividers removable and adjustable. Dividers interchangeable on most shelves. All Models Available With: "A" compartment layout both sides. Combination "AB" with "A" layout on roadside and "B" layout on curbside. Bumpers are optional at additional cost





CLASSIC II SPACEMAKER® MODEL

Spacemaker® Service Bodies

- Feature top-opening compartments that provide 15% more storage space
- Reinforced lids feature two pneumatic props and rotary catches with push button release
- Protected by E-Coat priming and powder coat finish on steel models
- Available in same configurations and sizes as standard bodies

SPACEMAKER® BODIES

Model	Approx. Wt.		Cab-to-Axle	A	B	C	D	Approx. Compartment Clear Door Openings					J	K	L	M
	Steel	Alum.						E	F	G	H	I				
**S78-SWs	992 lbs.	546 lbs.	40"	18"	42"	18"	78"	12-1/2" x 33-3/8"	40-1/2" x 11-7/8"	12-1/2" x 33-3/8"	56-1/2" x 11-7/8"	12-1/2" x 16-1/4"	7-3/8"	14-3/4"	24"	41-1/2"
*S82-SW	1084 lbs.	574 lbs.	40"	17"	42"	23"	82"	11-1/2" x 33-3/8"	40-1/2" x 11-7/8"	17-1/2" x 33-3/8"	61-1/2" x 11-7/8"	17-1/2" x 16-1/4"	7-3/8"	14-3/4"	24"	41-1/2"
S98-SWs	1182 lbs.	657 lbs.	56"	28"	47"	23"	98"	22-1/2" x 33-3/8"	45-1/2" x 11-7/8"	17-1/2" x 33-3/8"	66-1/2" x 11-7/8"	17-1/2" x 16-1/4"	7-3/8"	14-3/4"	24"	41-1/2"
S98-DWs	1336 lbs.	731 lbs.	56"	28"	47"	23"	98"	22-1/2" x 33-3/8"	45-1/2" x 11-7/8"	17-1/2" x 33-3/8"	66-1/2" x 11-7/8"	17-1/2" x 16-1/4"	7-3/8"	14-3/4"	24"	41-1/2"
US108-SWs	1308lbs.	721 lbs.	60"	33"	47"	28"	108"	27-1/2" x 33-3/8"	45-1/2" x 11-7/8"	22-1/2" x 33-3/8"	71-1/2" x 11-7/8"	22-1/2" x 16-1/4"	7-3/8"	14-3/4"	24"	41-1/2"
US108-DW	1437 lbs.	831 lbs.	60"	33"	47"	28"	108"	27-1/2" x 33-3/8"	45-1/2" x 11-7/8"	22-1/2" x 33-3/8"	71-1/2" x 11-7/8"	22-1/2" x 16-1/4"	7-3/8"	14-3/4"	24"	41-1/2"

Installers Notes:

* 2017 Ford Super Duty chassis only | ** E-Z mounting installation not available on these models
s Equipped with spring shackle offsets. Dimensions are 12 3/4" h x 4" deep.

SPACEMAKER® BODY DIAGRAMS

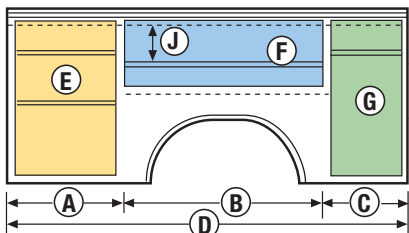

"A" Compartment Layout

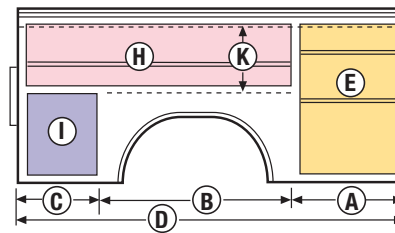

"B" Compartment Layout

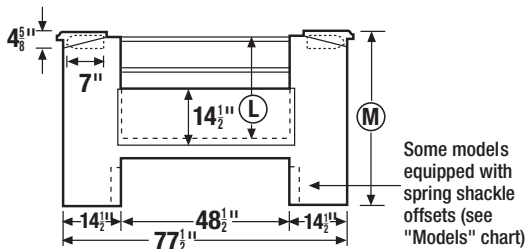

Single Wheel Rear View

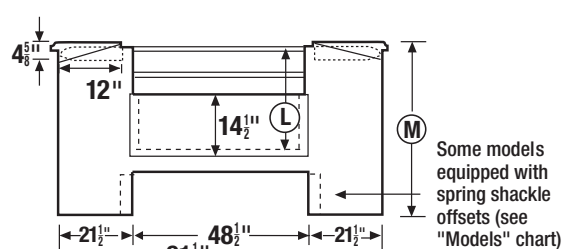

Dual Wheel Rear View

132 BODIES

Model	Approx. Wt.		Cab-to-Axle	Approx. Compartment Clear Door Openings					
	Steel	Alum.		A	B	C	D	E	F
U132-DW	1502 lbs.	893 lbs.	84"	27-1/2"x33-3/8"	17-1/2"x33-3/8"	45-1/2"x11-7/8"	22-1/2"x33-3/8"	22-1/2"x16-1/4"	71-1/2"x11-7/8"
SPACEMAKER MODEL									
US132-DW	1736 lbs.	997 lbs.	84"	27-1/2"x33-3/8"	17-1/2"x33-3/8"	45-1/2"x11-7/8"	22-1/2"x33-3/8"	22-1/2"x16-1/4"	71-1/2"x11-7/8"

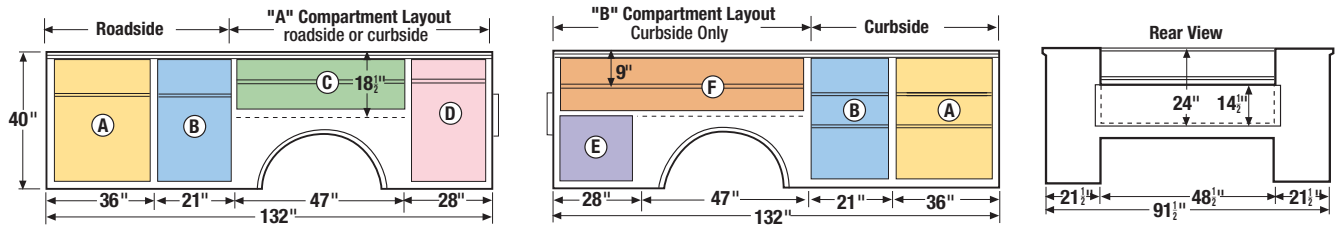

Optional crane reinforcement available at added cost upon request. Reading also manufactures "Cranemaster" bodies which are specifically engineered for crane use. Capacity restrictions may apply.

Standard Shelf and Divider Equipment

All shelves and dividers removable and adjustable.

STEEL SLIDING TOPS

Model	For Body	Approx. Wt.		A	B	C	D	E
		Steel	Alum.					
ST-78	78SW	145 lbs.	80 lbs.	40-1/4"	37-1/4"	—	77-1/2"	50-7/8"
ST-98	98SW/DW	155 lbs.	86 lbs.	49-3/4"	47-3/4"	—	102"	50-7/8"
ST-108	108SW/DW	170 lbs.	95 lbs.	55-1/4"	52-1/4"	—	107-1/2"	50-7/8"
ST-108HD	HD-108	225 lbs.	—	55-1/4"	53-7/8"	—	107-1/2"	52-3/8"
ST-120HD	HD-120	350 lbs.	—	40-3/4"	40-3/4"	40"	119-3/4"	52-3/8"
ST-132HD	HD-132	370 lbs.	—	44-3/4"	44-3/4"	44"	131-3/4"	52-3/8"
ST-150HD	HD-150	410 lbs.	—	50-3/4"	50-3/4"	50"	149-3/4"	52-3/8"

- Available in two or three sections (depending on body size)
- Slides on full-length galvanized steel tracks
- Secured with a two-point positive action stainless steel T-handle lock

Models ST78 – ST108HD with Teflon Sliders

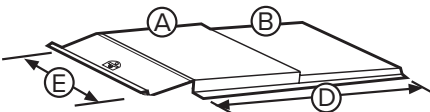

Models ST120HD – ST150HD with Roller Bearings

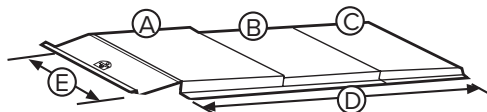

HEAVY-DUTY BODIES

Model	Approx. Wt.	Cab-to-axle	Approx. Compartment Clear Door Openings						
			A	B	C	D	E	F	G
HD108	1414 lbs.	60"	29-1/4"x38-1/2"	45-1/2"x14"	20-3/4"x38-1/2"	69-3/4"x14"	20-3/4"x21-3/8"	—	—
HD120	1761 lbs.	72"	36-1/2"x38-1/2"	48-1/2"x14"	20-3/4"x38-1/2"	72-1/2"x14"	20-3/4"x21-3/8"	—	—
HD132	2182 lbs.	84"	22-1/2"x38-1/2"	48-1/4"x14"	20-3/4"x38-1/2"	72-1/2"x14"	20-3/4"x21-3/8"	35"x38-1/2"	11-1/2"x38-1/2"
HD150	2536 lbs.	102"	20-1/2"x38-1/2"	48-1/4"x14"	20-3/4"x38-1/2"	72-1/2"x14"	20-3/4"x21-3/8"	—	—

Heavy-duty bodies are designed for chassis 1½ ton and over with dual rear wheels

HD108

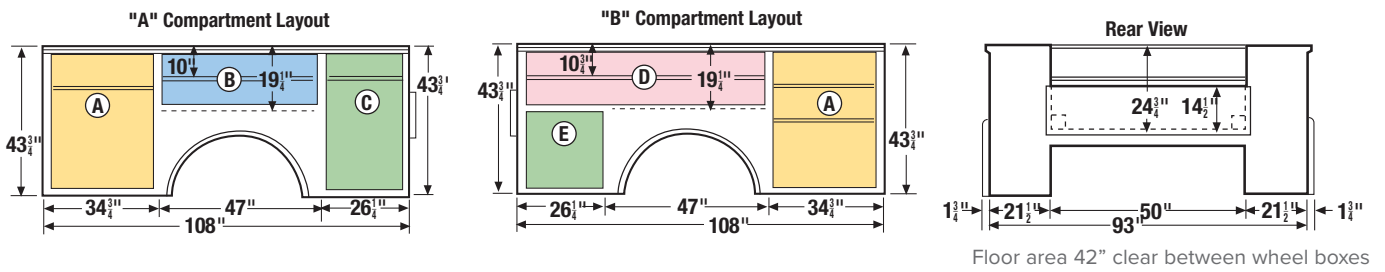

HD120

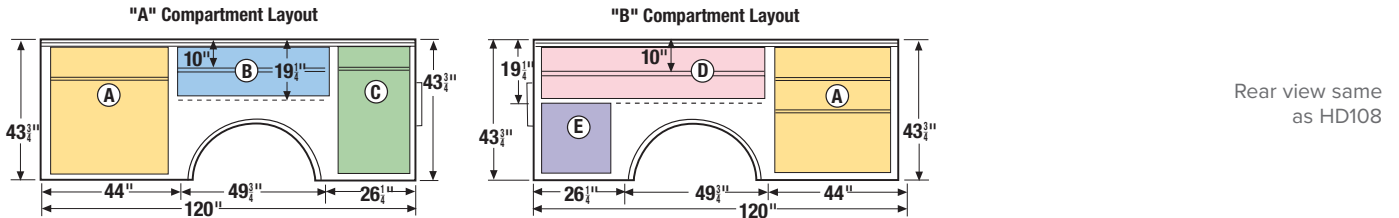

HD132

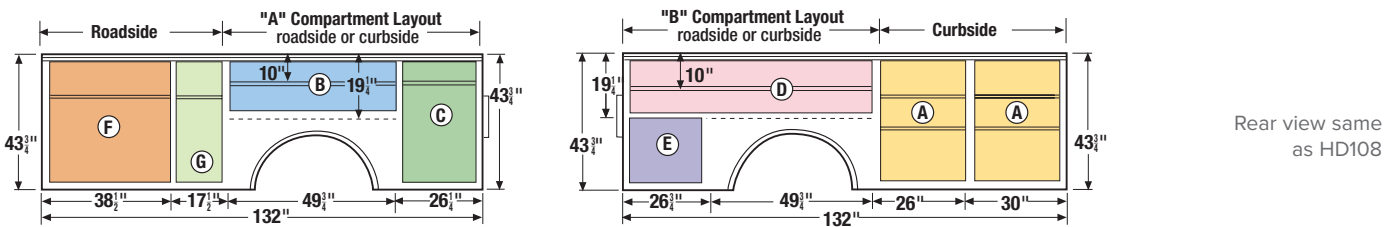

HD150

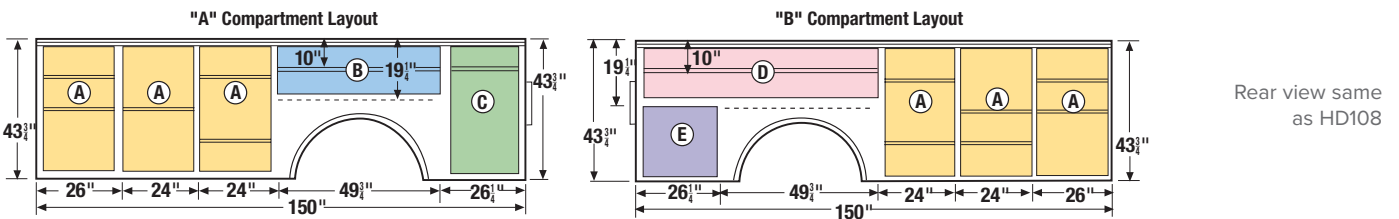

ENCLOSURES FOR CLASSIC II™ BODIES

Need a service body with an enclosed work space? Reading Enclosed Bodies are the answer. Equipped with spacious outside storage compartments and featuring a completely enclosed cargo and work area, Reading enclosed bodies offer the best of both worlds.

Panel Bodies

- Rear doors close and lock securely with 2-point locking system
- Available in galvanized steel or high-strength aluminum
- Protected by E-Coat priming and powder coat finish
- Enclosed area has full length shelves on each side to provide carrying space for long-handled tools and equipment



108SW Tapered Panel Body 60 Series
(Ladder rack, grab handle and foot step are optional)

PANEL BODIES

50 Series – 50" inside head clearance						
Model	Approx. Wt.*		Dimensions			
	Steel	Alum.	A	B	C	Length
TAPERED PANEL TOPS						
TPA50-98SW**	565 lbs.	291 lbs.	63-1/2"	6-1/4"	48-1/2"	98"
TPA50-108SW**	602 lbs.	310 lbs.	63-1/2"	6-1/4"	48-1/2"	108"
TPA50-108DW	595 lbs.	287 lbs.	73-1/2"	11-1/4"	48-1/2"	108"
STRAIGHT PANEL TOPS						
PA50-98SW	503 lbs.	271 lbs.	64"	6-1/2"	48-1/2"	98"
PA50-108SW	535 lbs.	290 lbs.	64"	6-1/2"	48-1/2"	108"
PA50-108DW	697lbs.	—	75"	12"	48-1/2"	108"

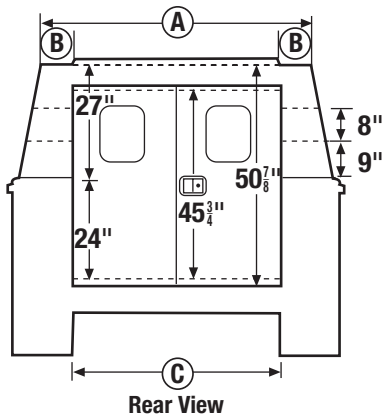

50 Series (TPA)

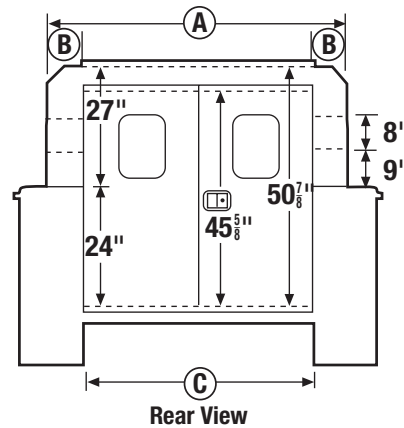

50 Series (PA)

60 Series – 60" inside head clearance						
Model	Approx. Wt.*		Dimensions			
	Steel	Alum.	A	B	C	Length
TAPERED PANEL TOPS						
TPA60-98SW**	643 lbs.	330 lbs.	63-1/2"	6-1/4"	48-1/2"	98"
TPA60-98DW	735 lbs.	—	73-1/2"	11-1/4"	48-1/2"	98"
TPA60-108SW**	684 lbs.	357 lbs.	63-1/2"	6-1/4"	48-1/2"	108"
TPA60-108DW	783 lbs.	396 lbs.	73-1/2"	11-1/4"	48-1/2"	108"
TPA60-132DW	938 lbs.	466 lbs.	73-1/2"	11-1/4"	48-1/2"	132"
STRAIGHT PANEL TOPS						
PA60-98SW	581 lbs.	311 lbs.	64"	6-1/2"	48-1/2"	98"
PA60-98-DW	678 lbs.	—	75"	12"	48-1/2"	98"
PA60-108SW	617 lbs.	330 lbs.	64"	6-1/2"	48-1/2"	108"
PA60-108DW	723 lbs.	380 lbs.	75"	12"	48-1/2"	108"
PA60-132	871 lbs.	445 lbs.	75"	12"	48-1/2"	132"

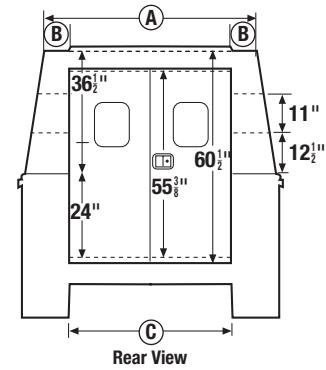

60 Series (TPA)

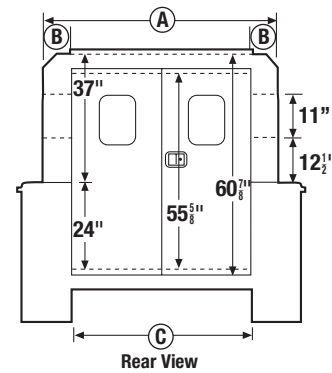

60 Series (PA)

72 Series – 72" inside head clearance						
Model	Approx. Wt.*		Dimensions			
	Steel	Alum.	A	B	C	Length
TAPERED PANEL TOPS						
TPA72-108DW	986 lbs.	—	73-7/8"	11-1/2"	48-1/2"	108"
TPA72-132DW	1178 lbs.	590 lbs.	75"	12"	48-1/2"	132"
STRAIGHT PANEL TOPS						
PA72-108DW	903 lbs.	—	75"	12"	48-1/2"	108"
PA72-132DW	1078 lbs.	552 lbs.	75"	12"	48-1/2"	132"

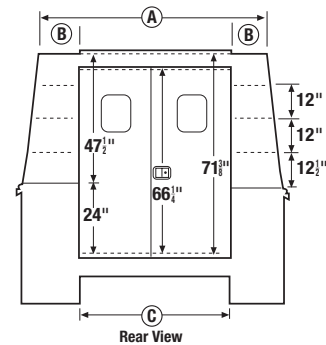

72 Series (TPA)

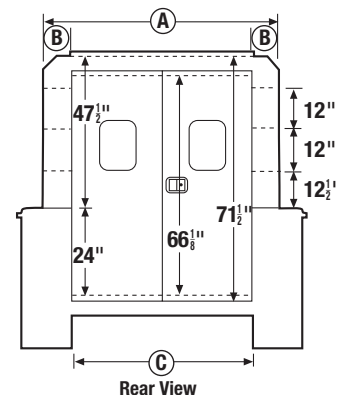

72 Series (PA)

ENCLOSURES FOR CLASSIC II™ BODIES

Spacemaster Bodies

- Enclosed work area, plus four lift-up doors
 - Upper roadside compartments permit direct access to the interior
 - Upper exterior doors feature pneumatic struts and T-handle locks
- Available in galvanized steel
- Protected by E-Coat priming and powder coat finish



108DW Tapered Panel Body 60 Series
(Ladder rack, grab handle and foot step are optional)

SPACEMASTER TOPS

Model	Approx. Wt.*	Cab-to-axle	A	B	F	G	H	I	J	K
	Steel									
SPM57-98DW	761 lbs.	56"	98"	49"	73"	18"	48-1/2"	11"	84-3/4"	12" x 42-3/4"
SPM57-U108SW**	745 lbs.	60"	108"	54"	62-7/8"	13"	48-1/2"	9"	74-5/8"	12" x 48-3/4"
SPM48-U108DW	696 lbs.	60"	108"	54"	72-1/2"	18"	48-1/2"	11"	84-3/4"	7-7/8" x 48-3/4"
SPM57-U108DW	815 lbs.	60"	108"	54"	73"	18"	48-1/2"	11"	84-3/4"	12-1/2" x 48-3/4"
SPM57-UR132DW	978 lbs.	84"	132"	44"	73"	18"	48-1/2"	11"	84-3/4"	11-3/4" x 39"

48 Series

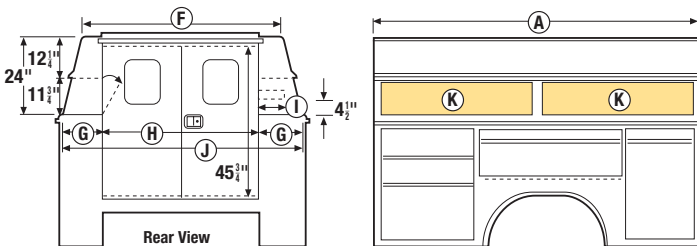

57 Series

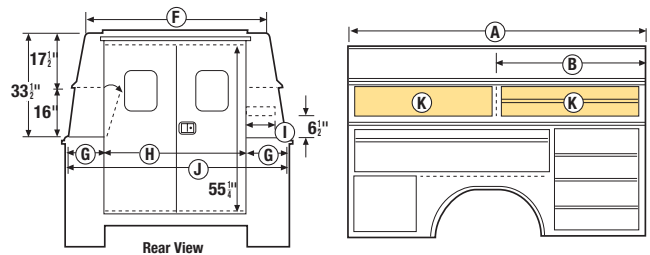

Installers Notes:

*Denotes Spacemaster top weight only. **Available factory installed only.
NOTE: SPM57-UR132 has (3) "K" compartments each side, equally spaced

Standard Shelf and Divider Equipment

All models feature 1 shelf and 4 dividers in curbside front compartment only. Shelves are removable and dividers are adjustable and removable

Dimensions and specifications for lower compartment areas correspond to Reading service bodies with equivalent model numbers (minus prefix SPM48 or SPM57) shown above



READING HAS A FULL LINE OF TRUCK BODIES TO CHOOSE FROM



Classic II Service Body – Steel



Classic II Service Body – Aluminum



Marauder Dump Body



Redi-Dek Body



SL Service Body



Classic Service Van - Aluminum



Platform Body



Landscaper SL Body



Panel Body



Ready Van SL – Steel



Marauder SL Dump Body



Drop Side Dump Body



Master Mechanic™ Crane Body



Master Mechanic™ Service Body



Stake Body



Custom Body



MADE FOR MORE

At Reading Truck, our work is our life. And we know it's yours, too. That's why our truck bodies have always been made with your work in mind. We created the first all-aluminum truck body over 35 years ago, and continue to make innovation a priority in every durable, worry-free design we create. Our customers put our products to work in some of the harshest environments and toughest sites imaginable. They know the difference is in the Reading details: better hinges, lighter aluminum frames, and easier opening latches. These details make our truck bodies unlike any other. They're made to handle bigger payloads, extra miles, and harder work. Reading Truck Body. Made for more.



|

CLASSIC II

READINGBODY.COM





— NO BODY BETTER —

CORPORATE HEADQUARTERS:

825 E. Wyomissing Blvd.
Reading, PA 19611

READINGBODY.COM

Sold and Serviced Locally by



© 2018 Reading Truck Group. All rights reserved.

Version Number RTG18-CII-03

All dimensions subject to plus or minus tolerance of 1/4" and all dimensions and specifications are subject to change without notice. Some items displayed in photographs are optional. Aluma-Fill, Aluma-Chock, Dual-Pro, Extend-A-Shelf, Grip-'n-Glide, Latch-Matic, Marauder, Reading, Redi-Dek, Rhino Linings, Rugged American, S.M.A.R.T Racks, Spacemaker, Tool-Mates, and TUFF STUFF are registered trademarks of Reading Truck Group, LLC in the United States and some foreign countries.