

MAX LIFT CAPACITY

RET: 50,000 lbs.

EXT: 16,000 lbs.

MAX BOOM EXTENSION

RECOVERY: 112"

UNDERLIFT: 122"

MAX WORKING HEIGHT

202"

JERR-DAN®



ENGINEERED TO EXCEED

25-TON JFB WRECKER

Our newest addition to the family — all the bells and whistles you've come to expect from Jerr-Dan — in a more compact package.

Engineered with Jerr-Dan's exclusive Incident Management-Driven design methodology, this hardworking wrecker features:

- Roll-up storage doors – enhance ability to see and be seen road side
- Boom, winch and underlift control access from both sides of the vehicle for efficient, reliable operation
- An independent isolated body design which flexes with chassis movement to reduce the wear associated with extreme-use conditions
- Advanced LED lighting kit for high visibility



ENGINEERED TO EXCEED

The JFB polypropylene co-polymer constructed body is weather-tight, low maintenance and highly impact-resistant, with both rear and top access.

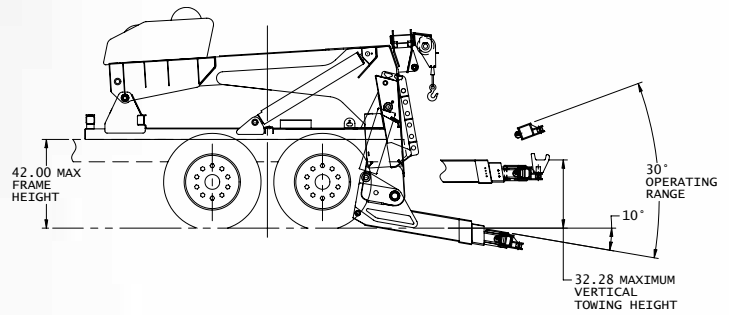

25-Ton Integrated	Single Axle	Tandem Axle
Recommended Chassis GVWR	33,000 lbs.	50,000 lbs.
Min Cab	To Axle (Clear CA): 157"	To Drive Tandem (Clear CT): 129"
Min Frame RBM (each rail)**	2,250,000 in-lbs.	2,250,000 in-lbs.
Min FAWR**	10,000 lbs.	12,000 lbs.
Min RAWR	21,000 lbs.	38,000 lbs.
Max Unloaded Frame Height	42"	42"
Min Frame Length Behind Rearmost Axle	43"	43"

**Higher minimums are required if mounting in combination with a Side Recovery System (SRS). Refer to SRS sales literature for requirements.

MORE TOW IN EVERY TON

Available in single and tandem body configurations, it boasts a 50,000 lb. two-stage wrecker boom with dual 25,000 lb. planetary winches.

Feature Dimensions*	Reach	Rating
A ¹ . Centerline of Rear Axle to Tailboard	40"	—
A ² . Centerline of Rear Tandem to Tailboard	67"	—
B. 350 Coach U/L Retracted Reach w/Forks	56"	28,000 lbs.
280 U/L Retracted Reach w/Forks	56"	28,000 lbs.
C. 350 Coach U/L Extended Reach w/Forks	122"	14,000 lbs.
280 U/L Extended Reach w/Forks	113"	14,000 lbs.
D. Recovery Boom Retracted Reach at 3°	12"	—
Recovery Boom Retracted Reach at 30°	-14"	50,000 lbs.
Recovery Boom Retracted Reach at 40°	-30"	—
Recovery Boom Extended Reach at 3°	112"	—
Recovery Boom Extended Reach at 30°	73"	16,000 lbs.
Recovery Boom Extended Reach at 40°	48"	—
E. Boom Working Height to Hook at 30°	171"	—
Boom Working Height to Hook at 40°	202"	—
F. Boom Max Height at 40° (Max)	234"	—
G. 350 Coach U/L Max Towing Height	32"	—
280 U/L Max Towing Height	32"	—

Note: All values based on a 42" truck frame height and are rounded to the nearest inch. Values are subject to change without notice.

*All dimensions are approximate.

Recovery Boom	Rating
Boom Retracted at 30°	50,000 lbs.
Boom Extended at 30°	16,000 lbs.

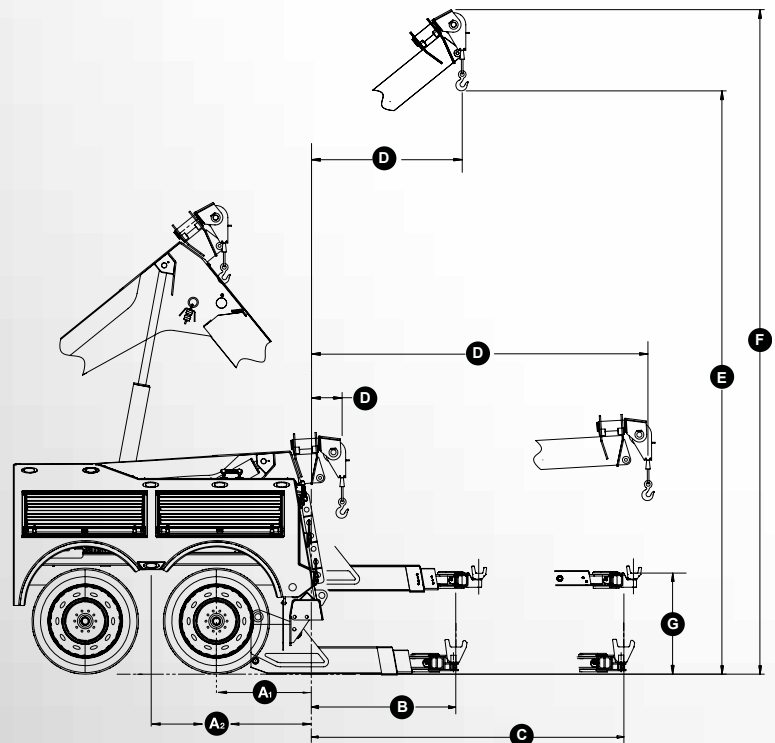

The Jerr-Dan name and Jerr-Dan logo are registered trademarks of Jerr-Dan Corporation. ©2019 Jerr-Dan Corporation. Some equipment shown may be optional. Specifications subject to change without notice or obligation. All ratings specified are based on structural factors only, not vehicle capacities or capabilities.

Part Number: 11100