

Guaranteed to run 16 hours on one battery charge\*

A great solution for applications demanding tight aisle racking, extensive product shuttling or frequent maneuvering in and out of trailers

Tight turning radius utilizing full traction control and dual drive motors for improved maneuverability

Adjustable suspended anti-fatigue floorboard

Electric adjustable armrest and backrest for improved operator comfort

Industry-leading 1,000 hour service intervals



## ETG 214-318

### Stand-Up Counterbalanced Lift Truck (3,000 - 4,000 lbs.)

The ETG 214-318 series of stand-up counterbalanced lift trucks from Jungheinrich® is an ideal material handling solution across a wide range of heavy-duty industrial applications. From shuttling goods to loading trailers, this lift truck has the flexibility to move large loads in confined spaces.

#### The key advantages:

- **Precise handling** - The ETG features a heavy-duty mast with durable rollers and mast rails designed to meet the most demanding applications. Combined with hydraulic cushioning in the mast staging functions, customize tilt speed and have electric tilt cushioning, operators can precisely and securely position loads at all lift heights.

- **Higher performance** due to advanced 3-phase AC technology. AC motors require no carbon brushes, which eliminates the cost of replacements, reduces the need for servicing and allows for longer operating times.

- **Space-saving** design for greater productivity. This means the forklift can work in smaller aisles where space is a premium versus the traditional sit-down counterbalanced truck, leaving more space available for product. Its design, plus one of the best turning radius in the industry (50.8"), means the truck can stack and retrieve goods efficiently. Operators can also customize the drive and hydraulic settings to suit their specific application and their level of experience.

- **Improved operator awareness** - The 4" HD full color display shows all the information needed to perform the task at hand. Operators have the flexibility to select a number of pre-programmed drive and hydraulic settings to customize the forklift for their particular application or operator skill level – all add up to increased confidence and a more productive work environment.

- **Industry-leading ergonomics** - Operators are more relaxed and productive largely due to the ergonomic compartment that helps minimize operator fatigue. The suspended anti-fatigue floor board helps to improve the ride experience adjusting the floor board based on the operators weight. Also the armrest and backrest are adjustable together to better fit the operators size, providing full comfort during the entire shift.

 **JUNGHEINRICH®**

# Technical data

Characteristics	0	Model		ETG 214		ETG 216		
	1	Load capacity at rated load center	lb	kg	3,000	1,364	3,400	1,591
	2	Rated load center – distance from fork face	in	mm	24	600	24	600
	3	Power voltage			36V AC electric		36V AC electric	
	4	Tire type – drive / steer			solid rubber / poly		solid rubber / poly	
5	Wheels – number front / rear (x=driven)			2x / 2		2x / 2		
Dimensions	6	Maximum fork height – standard triplex mast	in	mm	188	4,775	188	4,775
	7	Free fork height – standard triplex mast	in	mm	35	889	35	889
	8	Fork width	in	mm	3.9	100	3.9	100
	9	Fork thickness	in	mm	1.4	35	1.4	35
	10	Fork spacing – out-to-out (min. / max.)	in	mm	9.5 / 36.5	240 / 920	9.5 / 36.5	240 / 920
	11	Tilt angle – forward / backward	degree		3 / 5		3 / 5	
	12	Mast width	in	mm	22	570	22	570
	13	Length to fork face	in	mm	63.0	1,601	65.0	1,652
	14	Overall chassis width	in	mm	41	1,041	41	1,041
	15	Overall lowered height (mast)	in	mm	82.9	2,105	82.9	2,105
	16	Overall lowered height to top of overhead guard	in	mm	88.0	2,240	88.0	2,240
	17	Overall height with extended mast	in	mm	236.6	6,009	236.6	6,009
	18	Step height	in	mm	9.4	240	9.4	240
	19	Battery roller height	in	mm	7.0	178	7.0	178
20	Load moment constant <sup>2)</sup>	in	mm	12.2	310	12.2	310	
21	Minimum outside turning radius <sup>3)</sup>	in	mm	50.8	1,291	52.8	1,342	
22	Minimum aisle width 90° stack – zero clearance <sup>1)</sup>	in	mm	turning radius + load moment constant + load length + aisle clearance				
Performance	23	Travel speed – loaded / empty	mph	km/h	8 / 8	12.9 / 12.9	8 / 8	12.9 / 12.9
	24	Lift speed – loaded (triplex) (mast lift)	fpm	m/s	83	0.42	83	0.42
	25	Lift speed – empty (triplex) (mast lift)	fpm	m/s	118	0.60	118	0.60
	26	Lower speed – loaded (triplex)	fpm	m/s	102	0.52	102	0.52
	27	Lower speed – empty (triplex)	fpm	m/s	98	0.50	98	0.50
	28	Gradeability – loaded (maximum) at 1 mph / 1.6 km/h	%		15		15	
	29	Gradeability – empty (maximum) at 1 mph / 1.6 km/h	%		15		15	
Weights	30	Truck weight – empty with minimum weight battery	lb	kg	8,424	3,829	8,424	3,829
	31	Battery weight (minimum)	lb	kg	1,700	773	2,000	909
	32	Battery weight (maximum)	lb	kg	2,000	909	2,300	1,045
Wheels, Chassis	33	Chassis type (stand / sit)			stand-up		stand-up	
	34	Wheelbase <sup>4)</sup>	in	mm	41.7	1,059	43.7	1,110
	35	Ground clearance – center of wheelbase	in	mm	4.0	102	4.0	102
	36	Ground clearance – lowest point at mast	in	mm	3.0	76	3.0	76
	37	Tire size – drive	inches		16 x 7 x 10.5		16 x 7 x 10.5	
	38	Tire size – steer	inches		10 x 5 x 6.5		10 x 5 x 6.5	
	39	Brake type			electromagnetic disc		electromagnetic disc	
Electrical	40	Traction motor type			AC induction		AC induction	
	41	Traction motor output kW (60 minutes rating)	HP	kW	5.4 (x2)	4.0 (x2)	5.4 (x2)	4.0 (x2)
	42	Pump motor type			AC induction		AC induction	
	43	Pump motor output kW (15% rating)	HP	kW	17.4	13.0	17.4	13.0
	44	Steer motor type			AC induction		AC induction	
	45	Steer motor output kW (60 minutes rating)	HP	kW	0.9	0.7	0.9	0.7
	46	Battery – maximum capacity – A/H (6 hour rating)	Ah		1,240		1,240	
	47	Battery compartment length (front - back)	in	mm	14.25	362	16.25	413
	48	Battery compartment width (side - side)	in	mm	38.50	978	38.50	978
	49	Battery compartment height	in	mm	32.00	813	32.00	813

1) Add load length and operator clearance.  
2) Add 2.25" (57.0 mm) for quad masts; add 2.50" (63.5 mm) for hang-on side shift / hang-on shift fork positioner options; Add 1.00" (25.4 mm) for integrated side shift  
3) Turning Radius: battery compartment 14.25" = 50.8" (1291mm); battery compartment 16.25" = 52.8" (1342mm); battery compartment 18.25" = 54.8" (1393mm); battery compartment 21.25" = 57.8" (1469mm);  
4) Wheelbase: battery compartment 14.25" = 41.7" (1059 mm); battery compartment 16.25" = 43.7" (1110 mm); battery compartment 18.25" = 45.7" (1161 mm); battery compartment 21.25" = 48.7" (1237 mm);

This specification sheet only provides technical values for the standard truck. Non-standard tires, different masts, additional equipment, etc., could produce other values. Rights reserved for technical changes and improvements.

# ETG 214-318

0	ETG 318	
1	4,000	1,818
2	24	600
3	36V AC electric	
4	solid rubber / poly	
5	2x / 2	
6	188	4,775
7	35	889
8	3.9	100
9	1.6	40
10	9.5 / 36.5	240 / 920
11	3 / 5	
12	22	570
13	70	1,778
14	41	1,041
15	82.9	2,105
16	88.0	2,240
17	236.6	6,009
18	9.4	240
19	7.0	178
20	12.2	315
21	57.8	1,469
22	turning radius + load moment constant +load length + aisle clearance	
23	8 / 8	12.9 / 12.9
24	83	0.42
25	118	0.60
26	102	0.52
27	98	0.50
28	15	
29	15	
30	9,244	4,202
31	2,600	1,182
32	2,900	1,318
33	stand-up	
34	48.7	1,237
35	4.0	102
36	3.0	76
37	16 x 7 x 10.5	
38	10 x 5 x 6.5	
39	electromagnetic disc	
40	AC induction	
41	5.4 (x2)	4.0 (x2)
42	AC induction	
43	17.4	13.0
44	AC induction	
45	0.9	0.7
46	1,240	
47	21.25	540
48	38.50	978
49	32.00	813

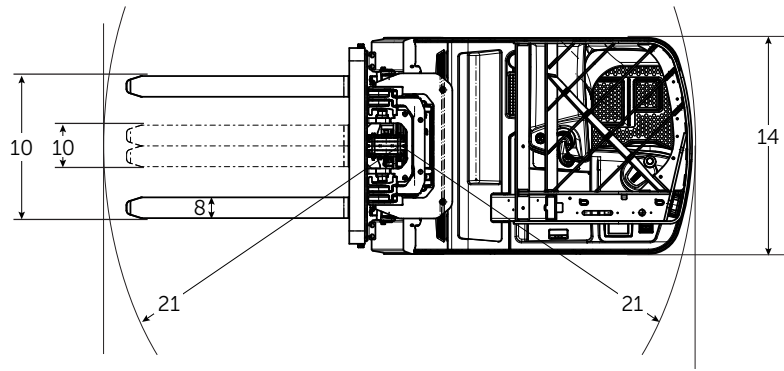
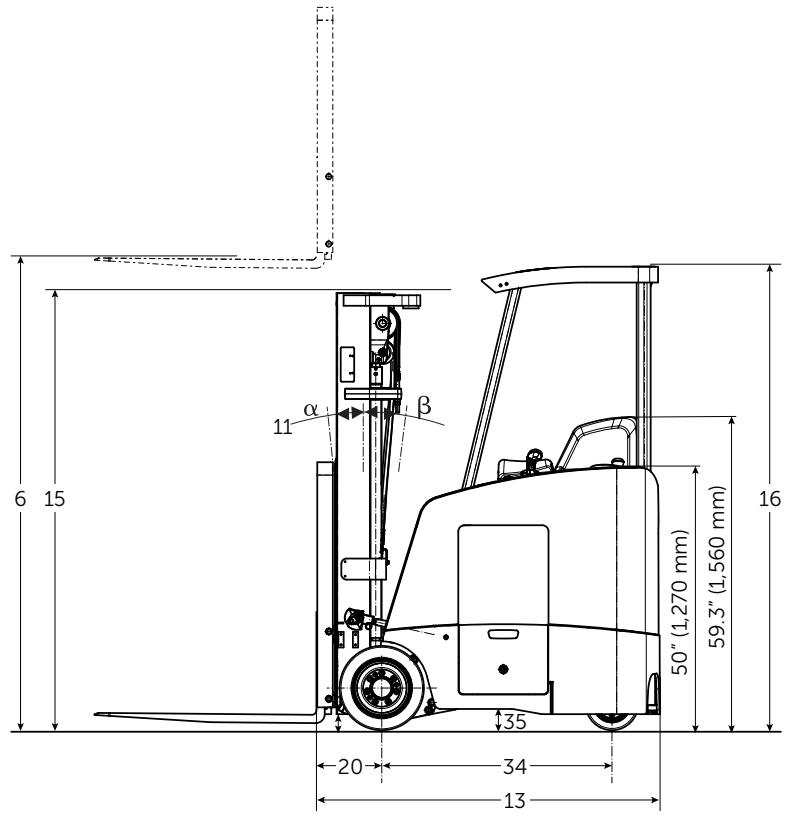

# The Jungheinrich Advantage



Multifunction Control Handle

## Spacious and ergonomic operator compartment

The spacious operator compartment combines comfort and functionality to improve operator efficiency.

- Location of operator controls allows for a flexible side stance position within the compartment.
- Low hood for excellent visibility to the fork tips.
- Up-to two USB ports (optional).
- Low-effort electric power steering for precise control with minimal effort.
- 4" HD full color informative and intuitive display.
- Electric actuated adjustable armrest.
- Backrest adjustable with the armrest.
- Intuitive multifunction control handle.
- Anti-fatigue suspended floor board adjustable and generous padding for knees, hips, back and armrest.
- Dual pedal design requires the operator to have their right foot on the presence pedal for all drive and hydraulic functions to operate. Additionally, the operator must have their left foot on the traction pedal to induce travel.
- Storage space for operator's equipment.
- Battery compartment rollers.
- Side gates.

## Efficient steering and maneuverability

Capable of handling maximum load capacities while remaining exceptionally maneuverable, the stand-up counterbalance is designed for extensive shuttling, frequent entering and exiting of trailers and tight turns in narrow spaces. The large, dual drive tires are independently controlled for improved lift truck maneuvering.



Anti-Fatigue Suspended Floorboard

## Optimal visibility / dependable hydraulics

The Jungheinrich hybrid mast offers optimal visibility between and around the overhead guard legs. This allows for increased efficiency in trailers and during travel and pick-up as well as in drive-in rack applications. Key features:

- AC-powered transistor hydraulic control.
- Industry-leading lift speeds with smooth and precise load control.
- Advanced pump motor, drive motor and control panel feature individual thermal protection systems to guard against overheating.
- Fork heights up to 276 inches.

## Operator display

The easy-to-read control panel displays the information needed to perform daily tasks, including:

- Travel speed.
- 360° steer direction indicator.
- Battery discharge indicator with lift interrupt.
- Event message indicator.
- Informational and warning icons.
- Language options.
- Parking brake indicator.
- Time display.
- Hour meter.
- Crawl speed indicator.
- Thermal limit indicator.
- Performance mode selector (1 To 3).
- Maintenance interval reminder.

## Customized programming

Performance profiling allows you to customize drive and hydraulic settings based on the specific application, individual operator experience level and personal preferences. All performance requests, information queries and display-based programming can be performed with easily accessible buttons.



Low-effort Electric Power Steering

## Powerful 3-phase AC technology

3-phase AC technology for drive, lift and steering offers several advantages over traditional direct current motors, including:

- Rapid acceleration and precise speed control.
- Smooth directional changes.
- Greater uptime due to maintenance-free motors without carbon brushes.
- Longer operating times due to energy reclamation during braking.

## Multifunction control handle

The intuitive, multifunction control handle is centrally positioned for easy access to key lift truck functions.

- Maximum efficiency through simultaneous operation of travel, lift and one auxiliary function.
- Rounded palm rest helps reduce operator fatigue over long shifts.

## Parts when you need them

Jungheinrich's Parts Fast or Parts Free Guarantee ensures next-business-day delivery by 5:00 PM of all Jungheinrich parts in the United States, or they're free, including freight. For customers in Canada and Mexico, the guarantee ensures shipping of parts within 24 hours from the time the order was placed by the dealer. See your local Jungheinrich dealer for program details.

\* Programs may be subject to change without notice and may vary by region. Please ask your local Jungheinrich dealer for complete terms and conditions. See 2-Shift Guarantee program terms and conditions document for complete details.