



Solo Ryzer & Economy Ryzer Tabletops

Sizes Include 42"x30", 48"x30", 60"x30", 72"x30"

Surface Material	Bottom Material	9 X[Y Material	Core Material
Laminate	Laminate	PVC	MDF

Seamless Corner Ryzer & V Ryzer Tabletops

Sizes Include 59"x59" & 55"x96"

Surface Material	Bottom Material	9 X[Y Material	Core Material
Laminate	Laminate	ÚXÔ	Particle Board

All 6 Ua Vcc Tabletops

Sizes Include 42"x30", 48"x30", 60"x30", 72"x30"

Surface Material	Bottom Material	9 X[Y Material	Core Material
Natural Óæ à[[Natural Óæ à[[Natural Óæ à[[Natural Óæ à[[

Economy & Solo Ryzer

(Dimensions in inches)

42" x 30"

(Pre-drilled holes and hardware provided)

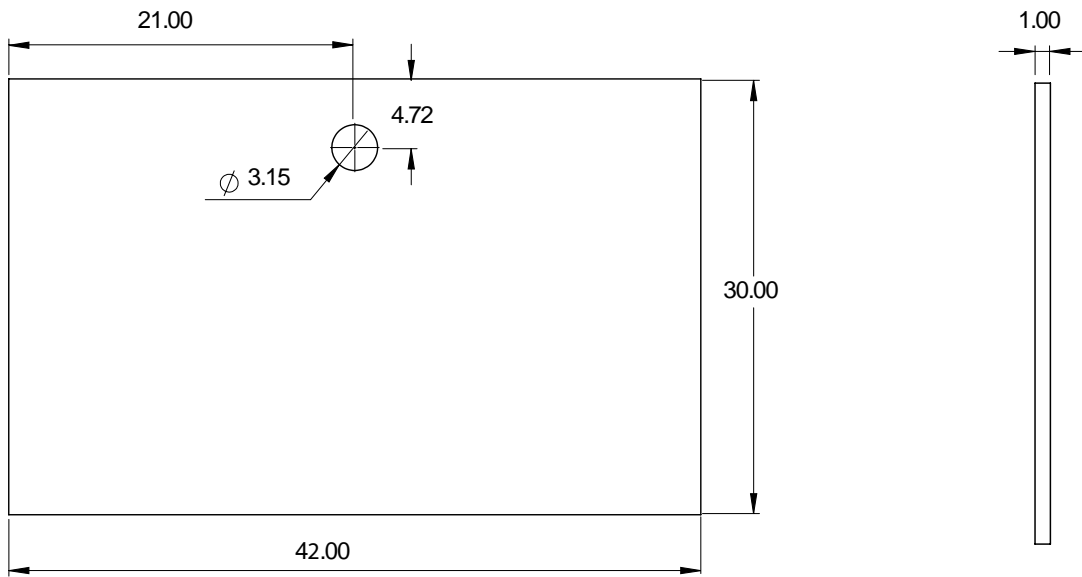

48" x 30"

(Pre-drilled holes and hardware provided)

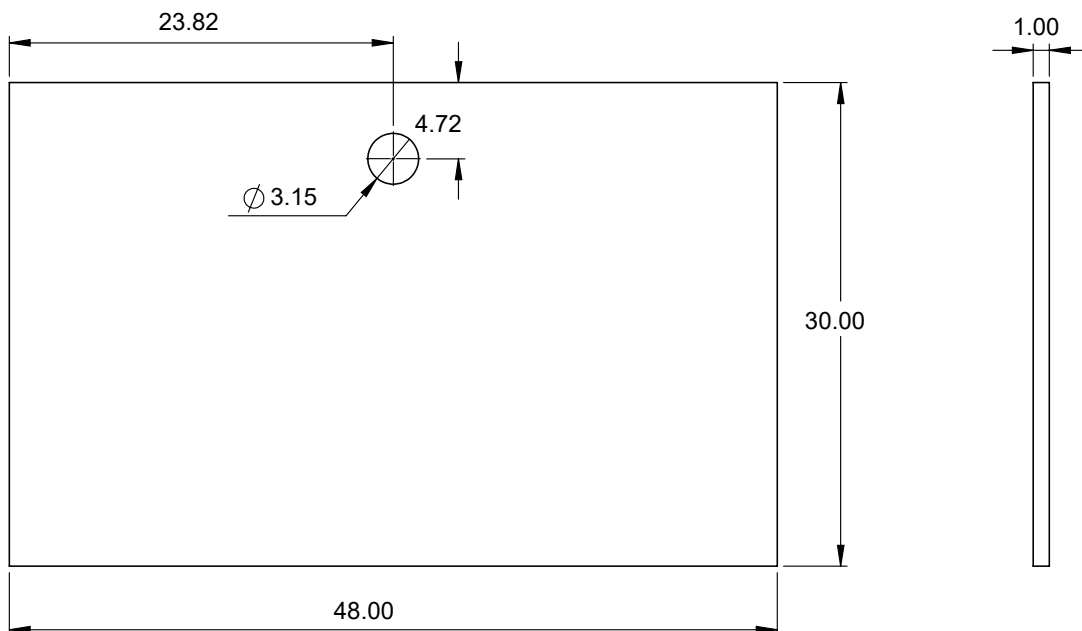

60" x 30"

(Pre-drilled holes and hardware provided)

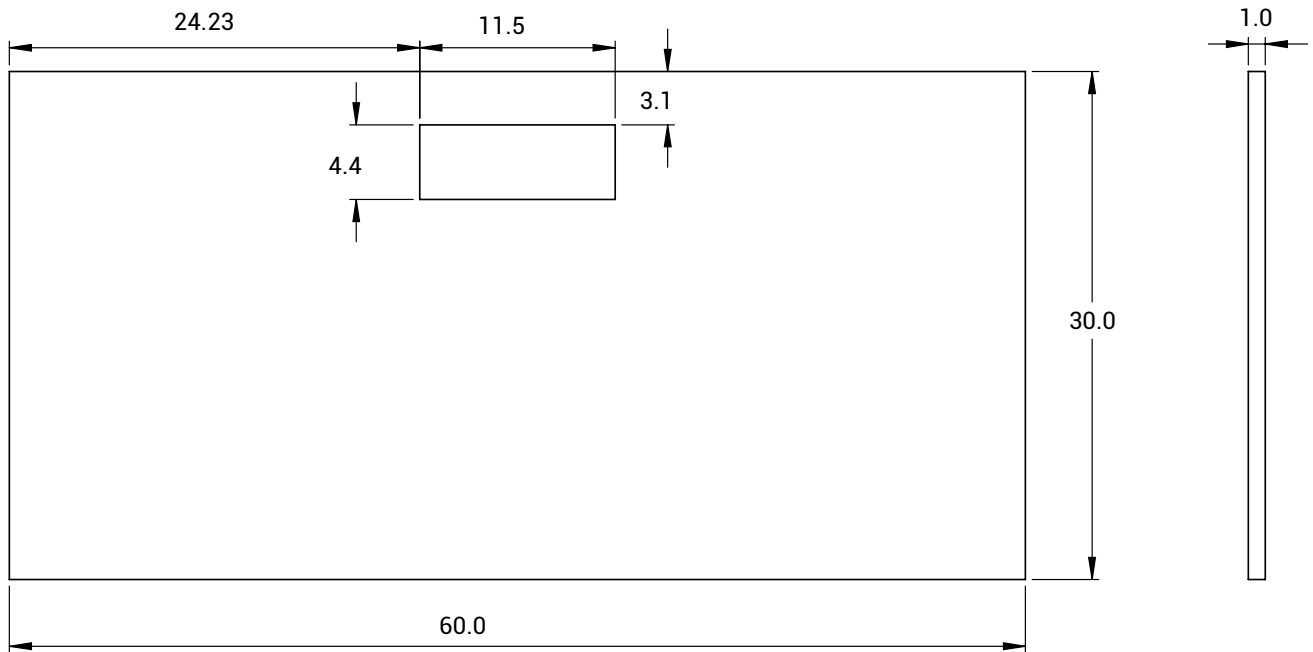
**72" x 30"**

(Pre-installed threaded screw inserts and hardware included.)

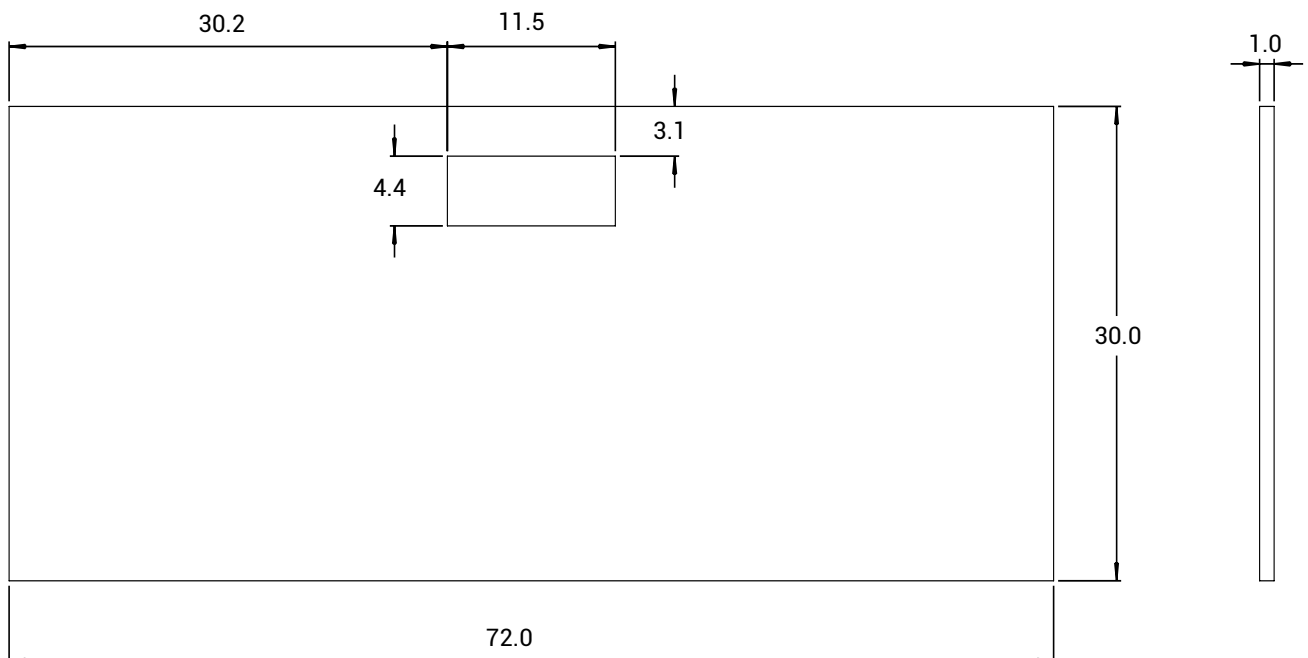

Corner Ryzer

(Dimensions in inches)

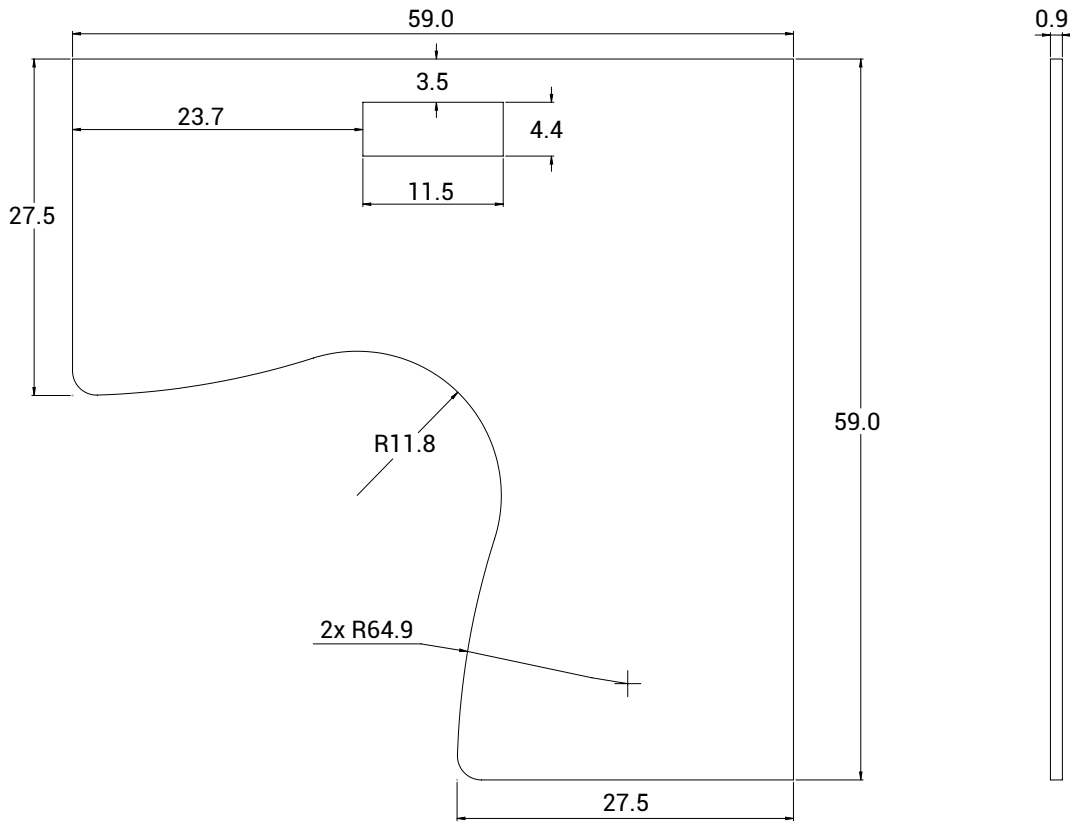

77.6" x 47.6"

(Pre-drilled holes and hardware provided)

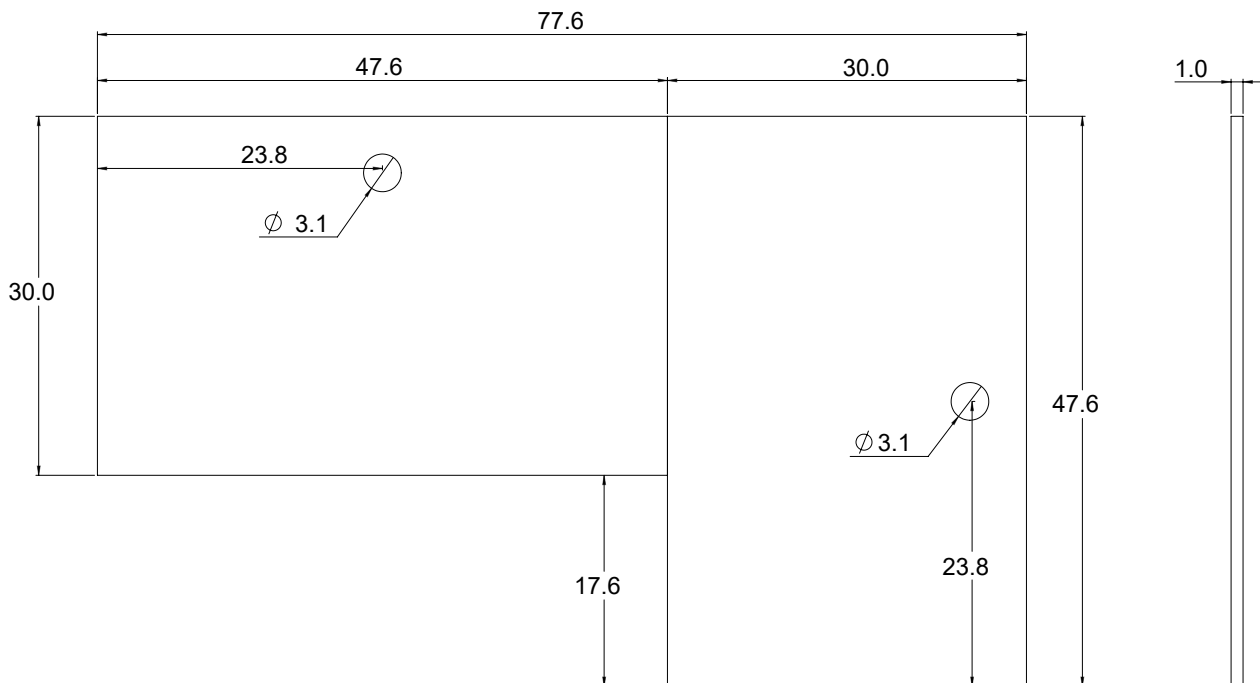

77.6" x 60.0"

(Pre-drilled holes and hardware provided)

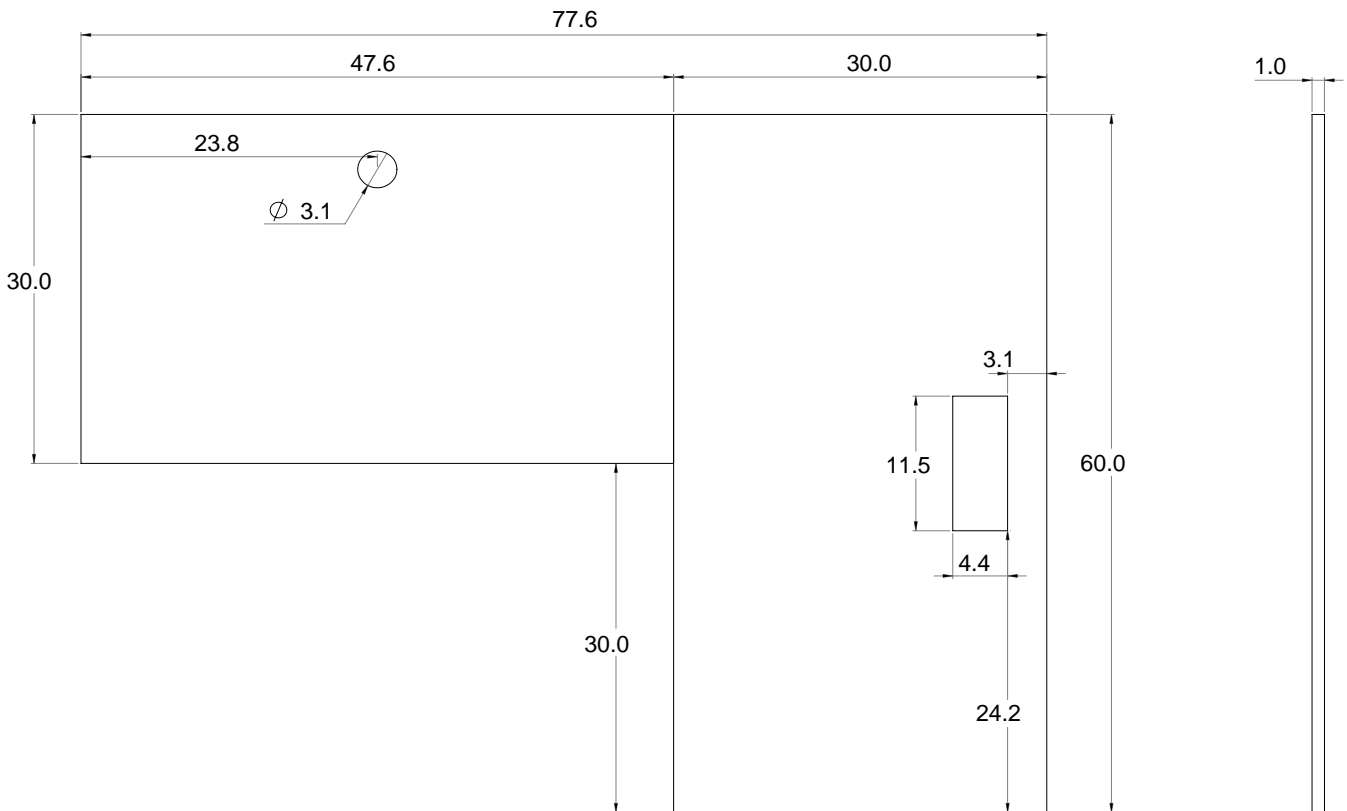
**90.0" x 60.0"**

(Pre-drilled holes and hardware provided)

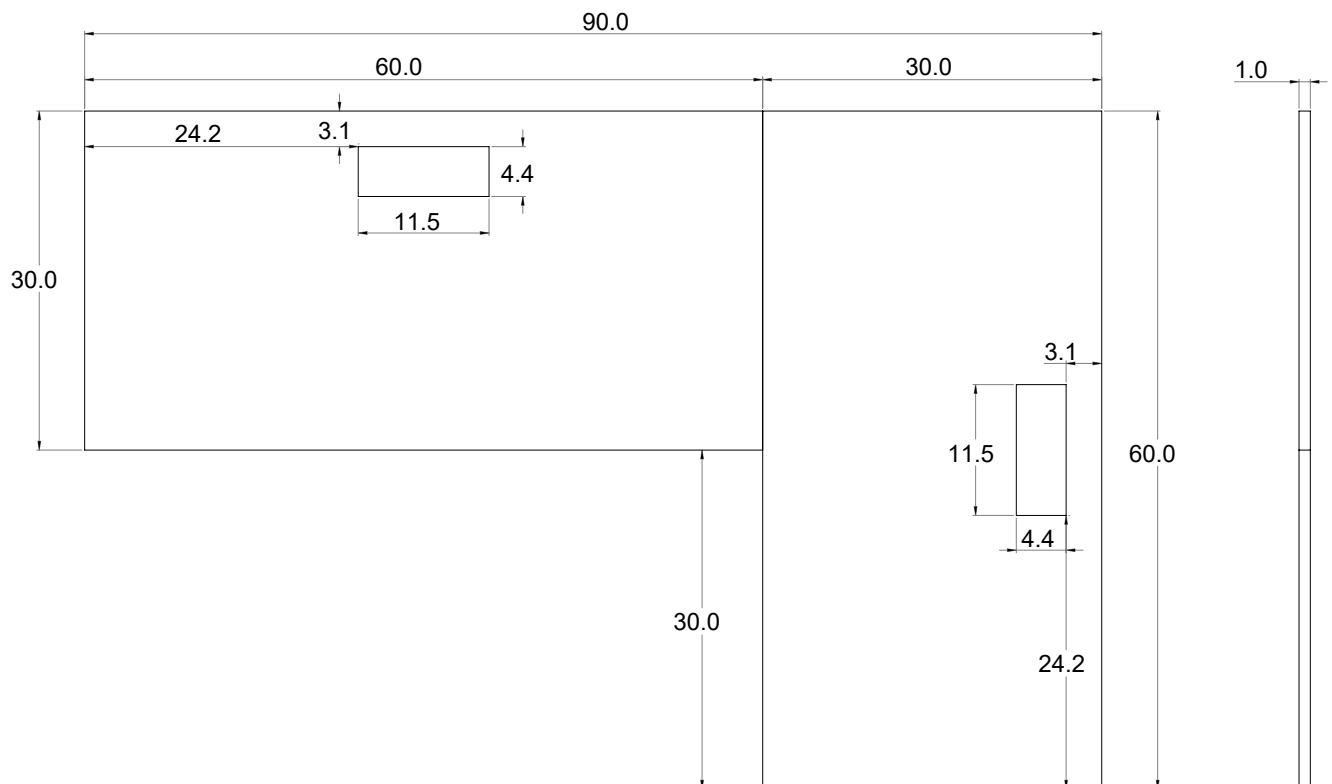

V Ryzer

(Dimensions in inches)

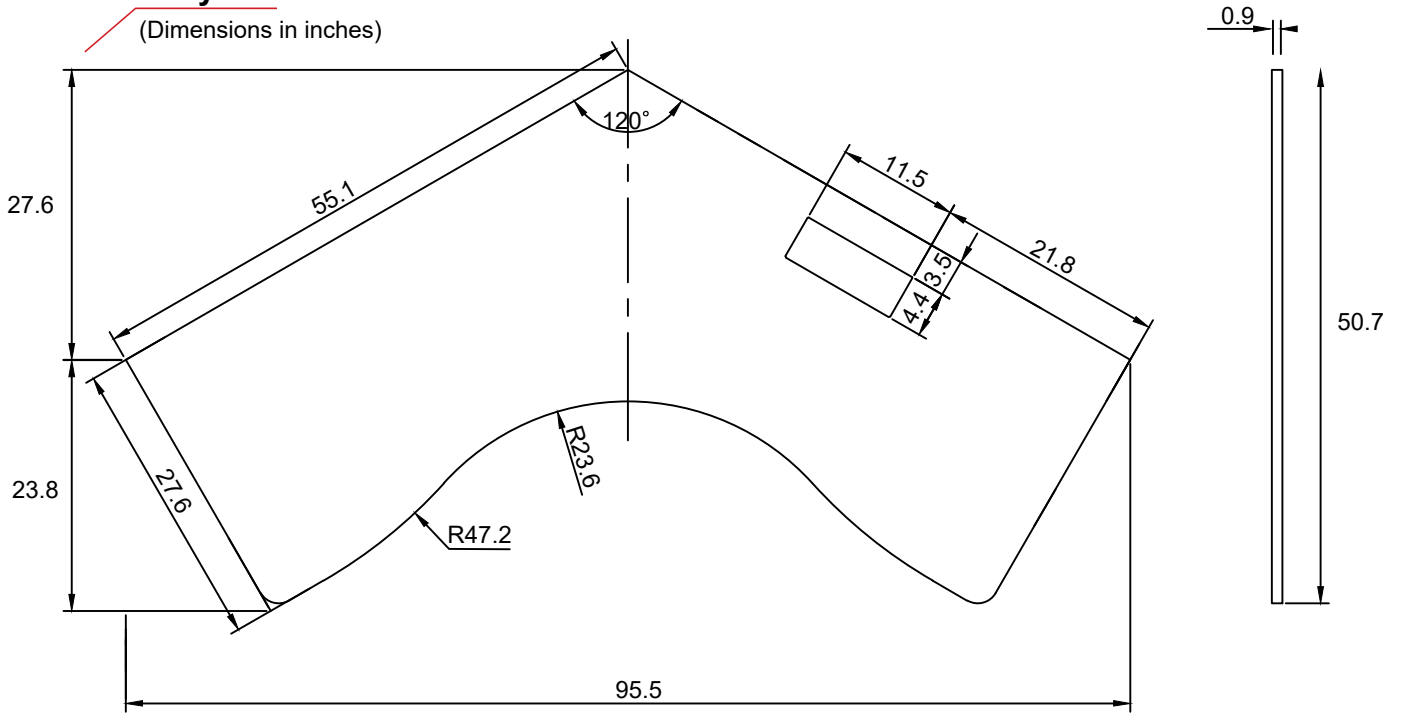

We provide additional peace of mind to all of our customers with our standard eight-year warranty. This warranty applies to all of our high quality standing desks. It is extremely rare for any issues to occur with our products, but you can rest assured if something goes wrong with any part of your desk, you can usually get a replacement under our eight-year warranty.

What is Covered?

Under our 15-year guarantee, Progressive Desk will send a replacement product to your home or office if you experience issues with the following components:

- Tabletops
- Desk Frame
- Desk Remotes

If a problem occurs, simply email us at sales@progressivedesk.com with your original order number and a brief description of the particular issue you are experiencing with the standing desk. Once our engineers assess the issue and determine that you require a replacement desk we will be happy to ship a new product immediately. We will also cover any ground shipping costs, so all you need to do is await the arrival of your replacement standing desk.

What is not Covered?

If you or your staff have made any type of modification to the desk this may make the item ineligible for replacement under the eight-year warranty. Other factors such as improper use and exposure to normal wear and tear at the workplace are also not covered by our warranty. Lastly, we are unable to cover items that have been lost or damaged due to an unavoidable accident like flooding or a hurricane.

Outside Warranty Coverage

Maintaining strong relationships with our existing customers is important to us at Progressive Desk. That is why we are pleased to offer special discounts on newer desk models to replace out of warranty items. If you're looking to update your existing standing desks, be sure to contact us and ask about our discounts.

Contact Us

PROGRESSIVE DESK CANADA

160-6691 Elmbridge Way
Richmond, British Columbia
V7C 4N1, Canada

PROGRESSIVE DESK USA

6015 180th Street, NE Ste #103
Arlington, Washington
98223, United States

MAILING & BILLING ADDRESS

11388 Steveston Hwy
PO Box 96007
Richmond, British Columbia
V7A 5J5, Canada

Toll Free: 1-800-828-9414

Toll Free Fax: 1-800-828-9414

Email: sales@progressivedesk.com