



Scan for more information

PA-18

User Manual

Table of Contents

Specifications.....	3
Dimensions.....	4
Load vs Speed/Current.....	5
Connectors & Feedback.....	6
Mounting Brackets.....	7
Internal Components.....	8
Internal Descriptions.....	9

Have any queries? Our expert engineers are here to help!



sales@progressiveautomations.com



1-800-676-6123



progressiveautomations.com

Specifications

Load (LBS)		No Load Current (A)		Full Load Current (A)		Speed (inch/sec)	
Dynamic	Static	12VDC	24VDC	12VDC	24VDC	No Load	Full Load
150	100	2.5	1.2	8.0	4.0	1.50	0.98
225	225	2.5	1.2	8.0	4.0	1.18	0.91
337	337	2.5	1.2	8.0	4.5	0.79	0.51
450	450	2.5	1.2	8.0	4.0	0.51	0.31
675	675	2.5	1.2	8.0	4.0	0.39	0.28
900	900	2.5	1.2	8.0	4.0	0.25	0.12

Stroke	1" to 40" (150lbs, 225lbs, 337lbs available up to 60")
Limit Switch	Internal - Non-Adjustable
Limit Switch Feedback	N/A
Screw Type	ACME Screw
Motor Type	Brushed DC Motor
Connector Type	See Page 6
Wire Length	60" (customizable)
Housing Material	Aluminum Alloy
Rod Material	Polyformaldehyde
Gear Material	Polyformaldehyde
Color (Shaft)	Silver
Color (Motor End)	Black
Noise	<48dB
Duty Cycle	20% (4 minutes on, 16 minutes off)
Operational Temperature	5°C to 40°C (23°F to 104°F)
Protection Class	IP20
Feedback Options	Hall Effect (optional)
Certifications	CE/RoHS
Mounting Brackets	See Page 7
Mounting Ends	Standard, Non-Customizable
Rear Mounting Hole Size	0.40"

Dimensions

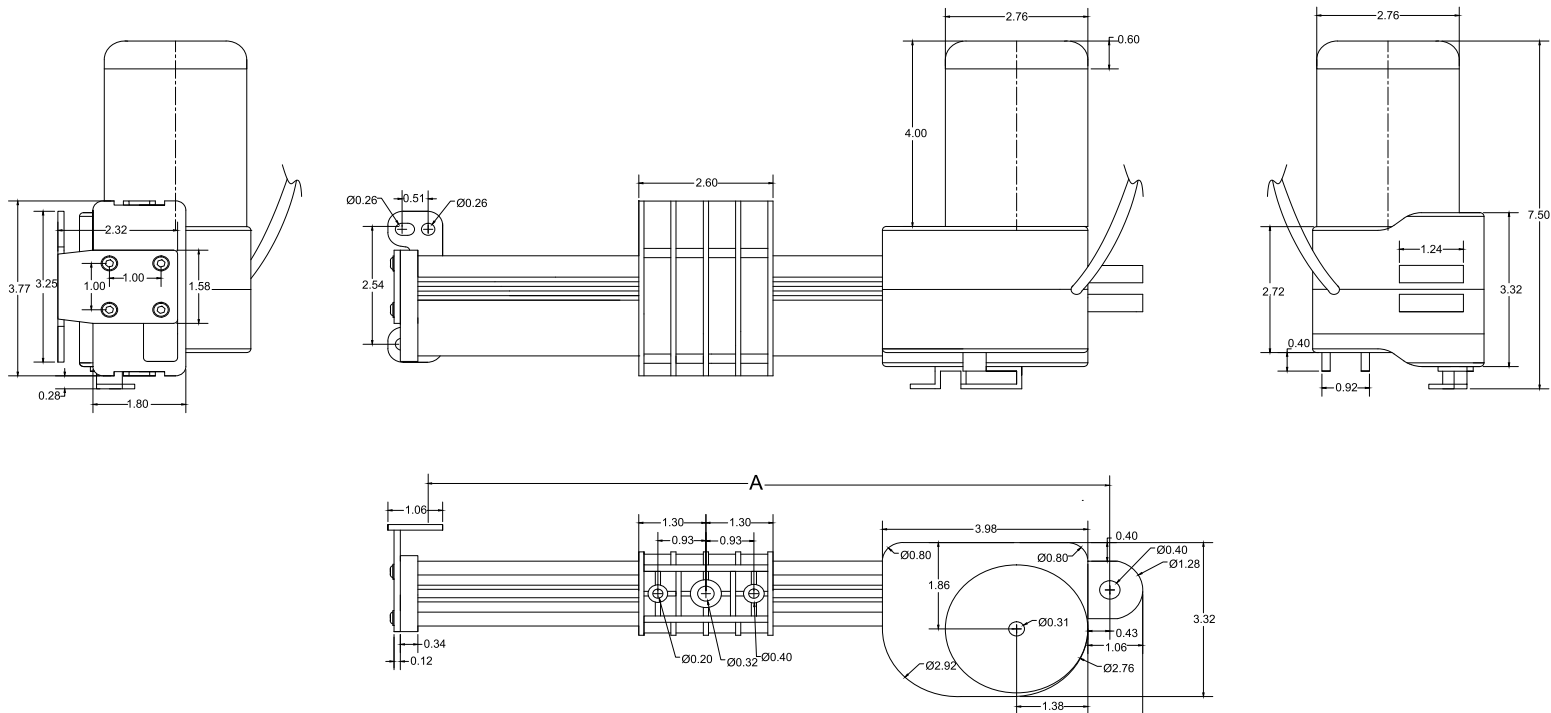

Hole to Hole

Stroke	1	2	3	4	6	8	9	10	12	14	16	18	20	22	24	30	40	50	60	
PA-18																				
A	8.68	9.68	10.68	11.68	13.68	15.68	16.68	17.68	19.68	21.68	23.68	25.68	27.68	29.68	31.68	37.68	47.68	57.68	67.68	

For Stroke Length

A = Stroke Length + 7.68"

Speed vs Load

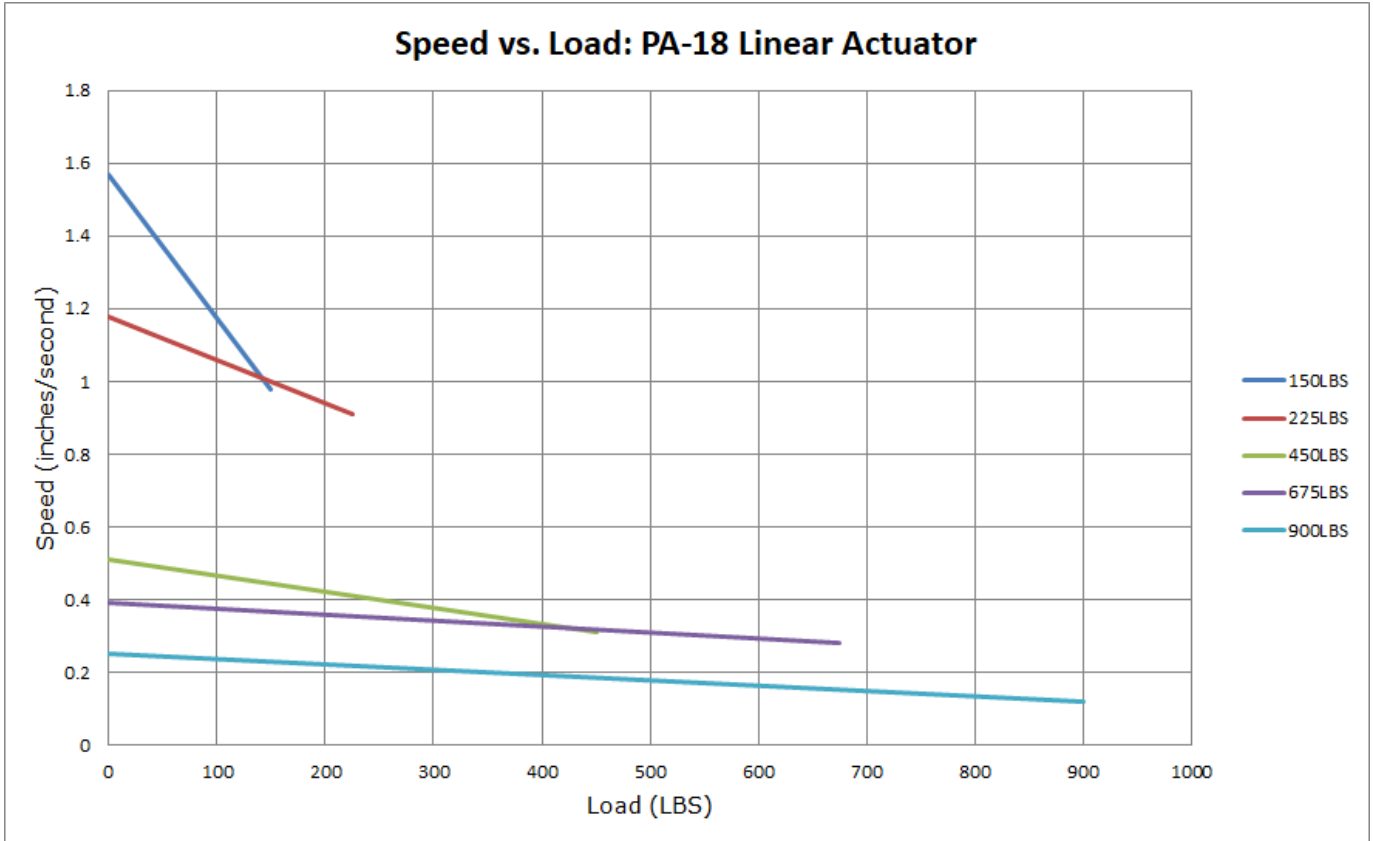

Current vs Load

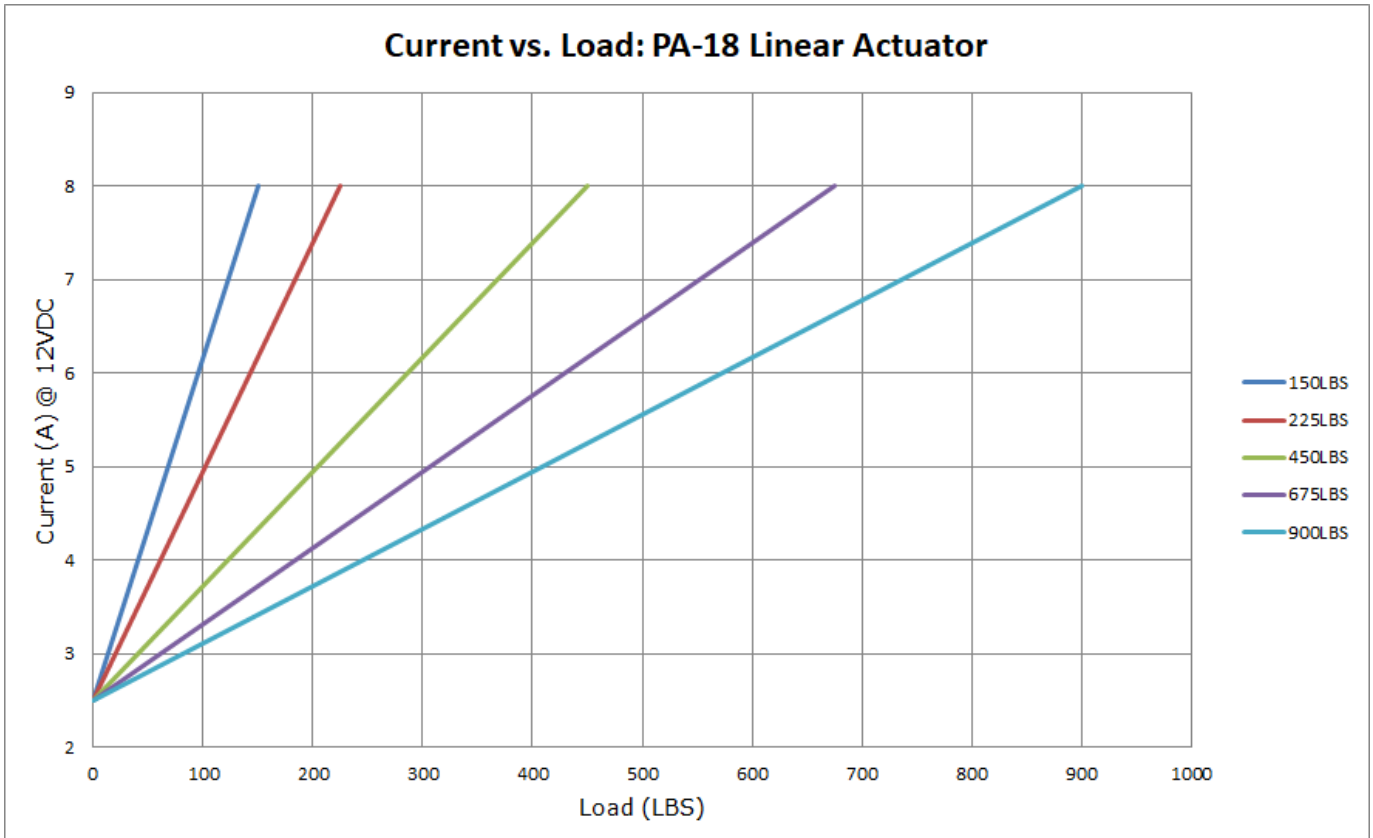

Connectors

2-Pin Connector (Standard)

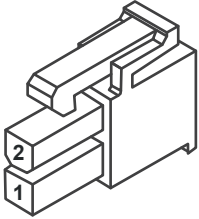

Motor	
1	2
M-	M+

Component	Part Name	Part Number	Mating Part Number
Housing	Molex Mini Fit Jr 2-Pin Receptacle	39-01-2025	39-01-2029 /39-01-2026

6-Pin Hall Effect Connector (Standard)

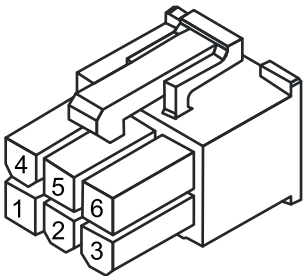

Motor		Hall Sensor			
4	5	2	3	1	6
M+ (Extend)	M- (Retract)	GND	+5VDC	Signal 2 Leads when Extending	Signal 1 Leads when Retracting

Component	Part Name	Part Number	Mating Part Number
Housing	Molex Mini-Fit Jr. 6-Pin Receptacle	39-01-2065	39-01-2069/ 39-01-2066

Output Signal Extending		Output Signal Retracting	
Hall Effect 1 Signal		Hall Effect 1 Signal	
Hall Effect 2 Signal		Hall Effect 2 Signal	

Mounting Brackets

(Dimensions in inches)

BRK-19

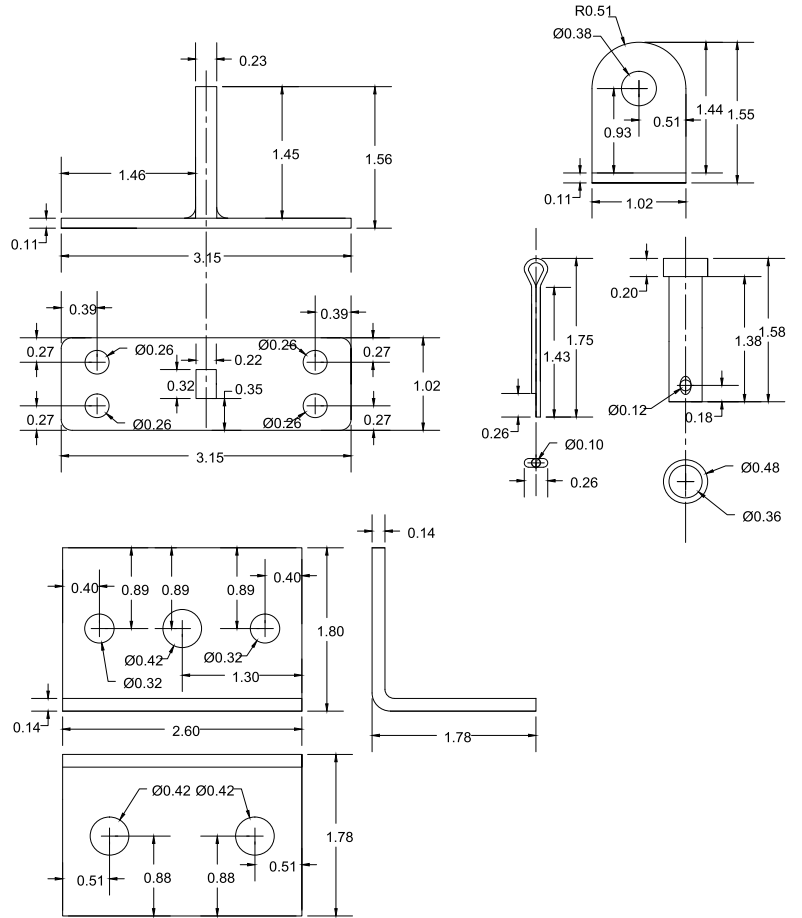

Bolt M10 x 1.5

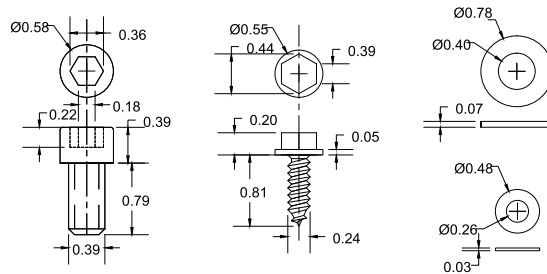

Bolt M6 x 1.0

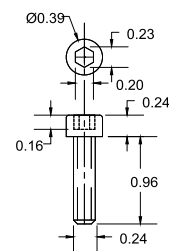

Internal Components

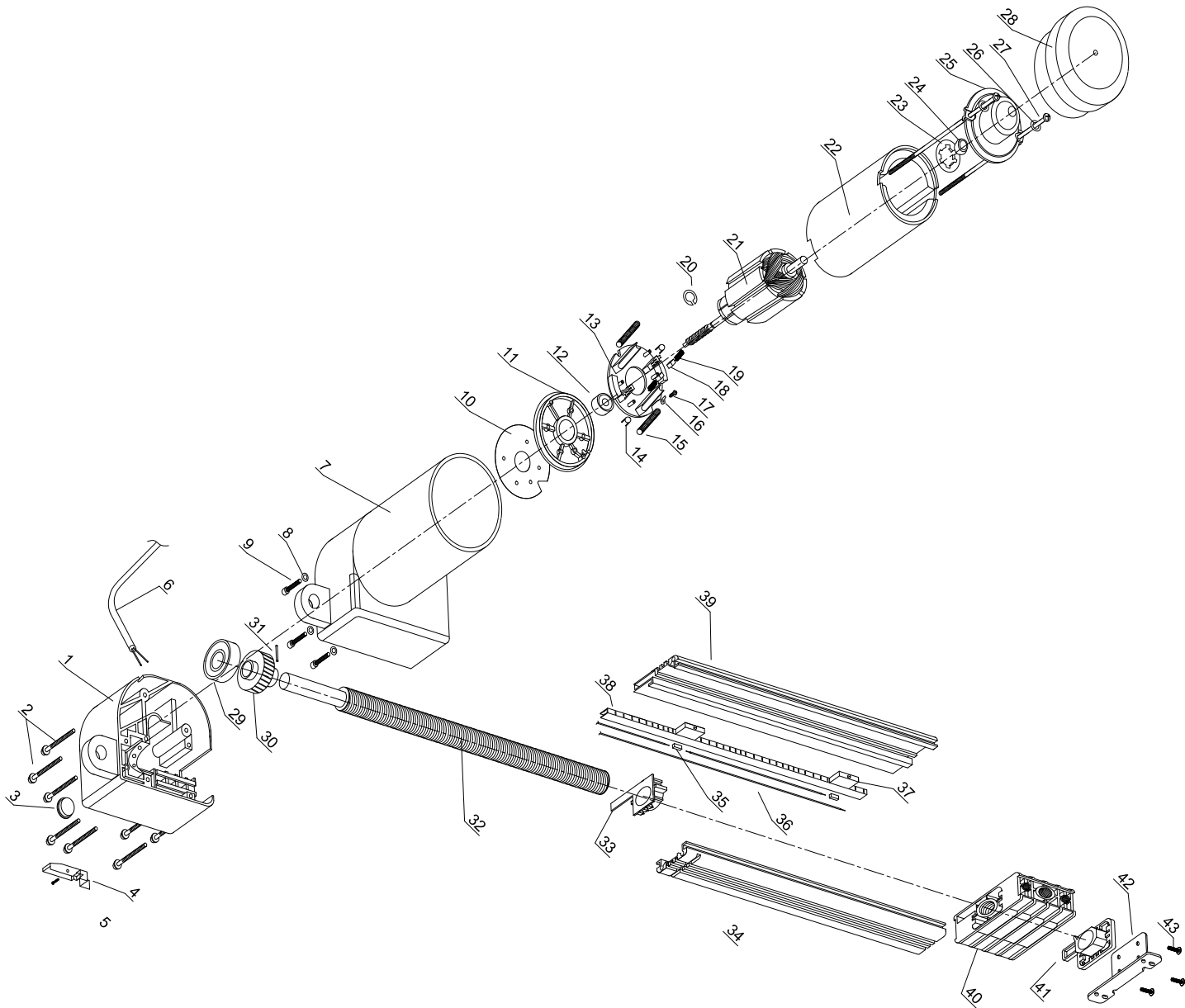

Internal Descriptions

Item	Description	Qty
1	Actuator Bottom Enclosure	1
2	Enclosure Screw	8
3	Maintenance Hole Cap	1
4	Mounting Bracket	1
5	Mounting Bracket Screw	1
6	Power Cable	1
7	Actuator Top Enclosure	1
8	Motor Washer	3
9	Motor Screw	3
10	Gasket	1
11	Motor Base	1
12	Motor Lower Bearing	1
13	Brush Holder PCB	1
14	Capacitor	2
15	Inductor	2
16	Cable Lock	1
17	Cable Lock Screw	1
18	Electric Motor Brush	2
19	Brush Spring	2
20	Locking Washer	1
21	Electric Motor Rotor	1
22	Electric Motor Enclosure With Stator	1

Item	Description	Qty
23	Top Bearing Holder	1
24	Top Bearing	1
25	Motor Top Enclosure	1
26	Motor Screw Washer	2
27	Motor Screw	2
28	Actuator Top Cap	1
29	Drive Bearing	1
30	Drive Gear Wheel	1
31	Drive Gear Wheel Pin	1
32	Drive	1
33	Drive Bottom Holder	1
34	Shaft Right Glider	1
35	Diode	2
36	Wire	1
37	Limit Switch	2
38	Limit Switch Base	1
39	Shaft Left Glider	1
40	Shaft	1
41	Drive Top Holder	1
42	Bracket	1
43	Bracket Screw	3