

White Paper

Saving energy and lowering product cost with multi speed fan motors in beverage merchandisers

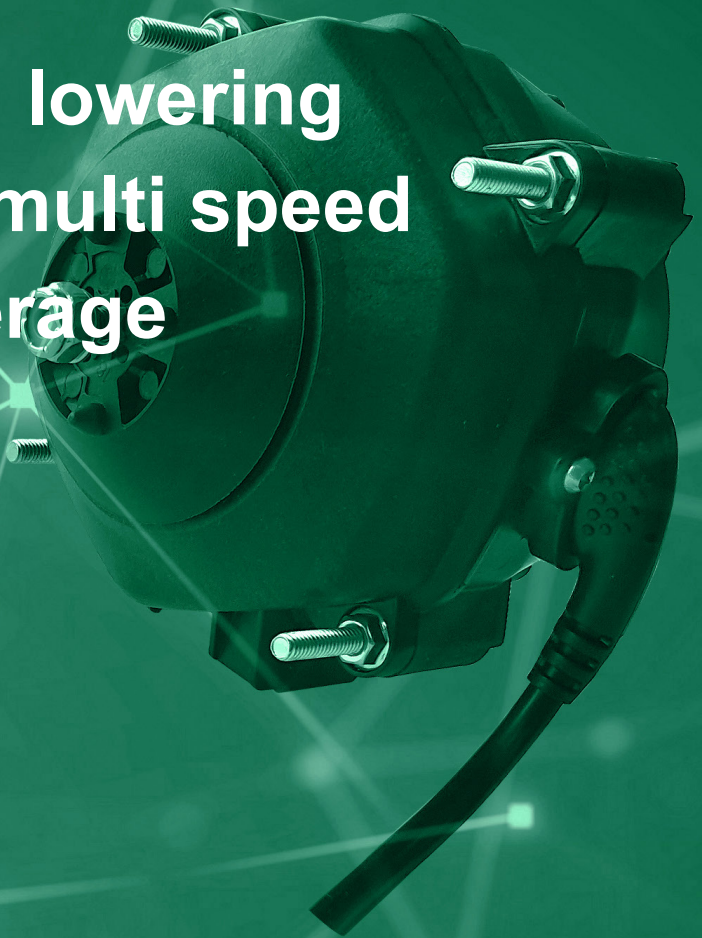

ECR[®] 2 motors reduce power consumption and thermal losses in beverage coolers and vending machines by switching the fan to low speed when the compressor is not operating. This is done by wiring the motor's control wire (black wire) directly into the compressor circuit. This eliminates the need and expense of a system controller with fan control outputs.

Most beverage merchandisers use an evaporator fan driven by a shaded pole or EC motor capable of operating at one speed. Usually this fan runs continuously. Continuous operation wastes energy because:

- When the compressor is off, no heat is being extracted from the cooler, so no airflow is required. Operating the motor during this time wastes energy. Additionally, all this power is being dissipated as heat inside the cooler, so even more power must be used by the compressor to extract this heat.
- Unnecessary airflow during the time when the compressor is off increases heat transfer through the cooler walls. This results in faster warming, shorter compressor-off periods, and more wasted energy.

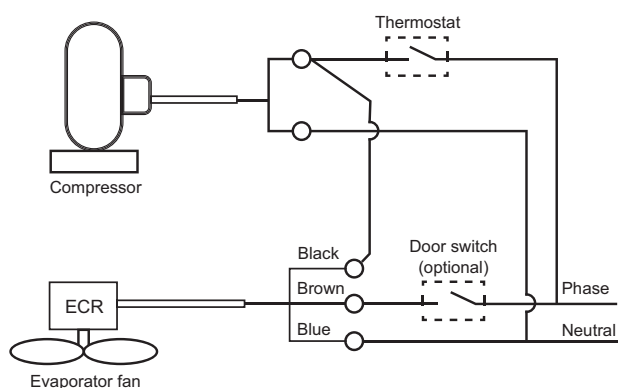

In coolers with system controllers, the evaporator fan runs continuously when the compressor is on. When the compressor is off, the fan is cycled on and off to reduce stratification of warm and cold air. This reduces wasted power, but several problems remain:

- Some power is still wasted due to the fan running at full power during the "on" part of the cycle.
- Some stratification still occurs during the off period, increasing the temperature variation of product, and often decreasing the products' quality.

- A system controller capable of independently controlling the evaporator fan is required.
- At fan turn-on, a pulse of warm air from the evaporator is circulated around the cooler, potentially causing false readings from the temperature sensor and reducing control effectiveness.

If a three speed ECR 2 is used, the evaporator fan may be switched to lower speed when the compressor is off. The advantages of this approach are:

- Air is circulated continuously, so stratification and false temperature readings are eliminated.
- The fan's energy consumption is proportional to fan speed cubed. So, during compressor-off periods a fan running continuously at part speed uses less power than one running intermittently at full speed, and significantly less power than one running continuously at full speed. For example, a fan operating at half speed uses about 1/8th the energy as a fan operating at full speed. That's an energy savings of over 87%!

- No system control connection is required. If a system controller is used, a low-cost unit without a fan control output is suitable.

For best results, the ECR 2 motor should be connected so that the motor runs at full speed when the compressor is on, at reduced speed when the compressor is off, and stops when the door switch is open.

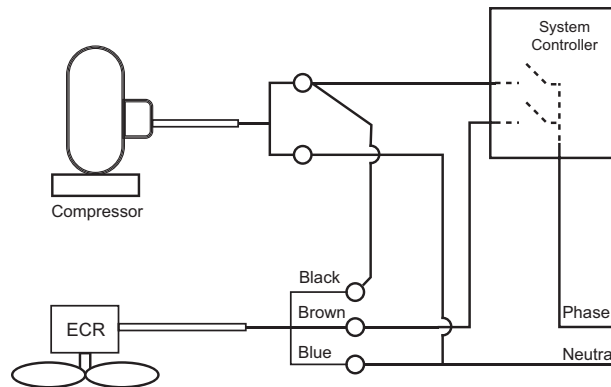

Let's make the world better

From protecting the food supply to ensuring medicines remain safe, refrigeration systems are critical for modern life as we know it. Wellington exists to deliver trusted technology for the real world that solves our customers unique problems. We believe that by collaborating with our OEM partners and placing our technology in every location, we will ensure a sustainable future with safe foods, beverages, and medicines for our families and future generations. We invite you to learn more about how Wellington can partner with you and build a better world together.

Authors:

Sue Sieben, *Application Engineer*, Wellington Drive Technologies US, Inc.

Michael Young, *Regional Director*, Wellington Drive Technologies US, Inc.

About Wellington Drive Technologies Limited:

Wellington is a leading provider of IoT solutions, cloud-based fleet management platforms, energy-efficient electronic motors and connected refrigeration control solutions. It serves some of the world's leading food and beverage brands and refrigerator manufacturers and offers proximity-based marketing for Smart Cities to the Australian market. Wellington's services and products improve sales, decrease costs and reduce energy consumption. Headquartered in Auckland with a global reach, Wellington is listed on the New Zealand stock exchange under the ticker symbol NZ: WDT

©2020 Wellington Drive Technologies Limited.

Trademarks are (as applicable) 'TM' and © of Wellington Drive Technologies Limited. While all information in this document is believed by Wellington Drive Technologies Limited to be accurate and reliable, Wellington Drive Technologies Limited and its subsidiaries and affiliates and their directors, officers and employees are not responsible for any errors or omissions of any kind whatsoever, and to the maximum extent permitted at law, have no liability in tort, contract, or otherwise to any user and/or any third party.

E: info@wdtl.com www.wdtl.com



Saving energy and lowering product
cost with multi speed fan motors in
beverage merchandisers

www.wdtl.com

WT9428_i2 07/20