

White Paper

Saving energy and lowering product cost with multi speed fan motors in closed-front supermarket and food service display cases

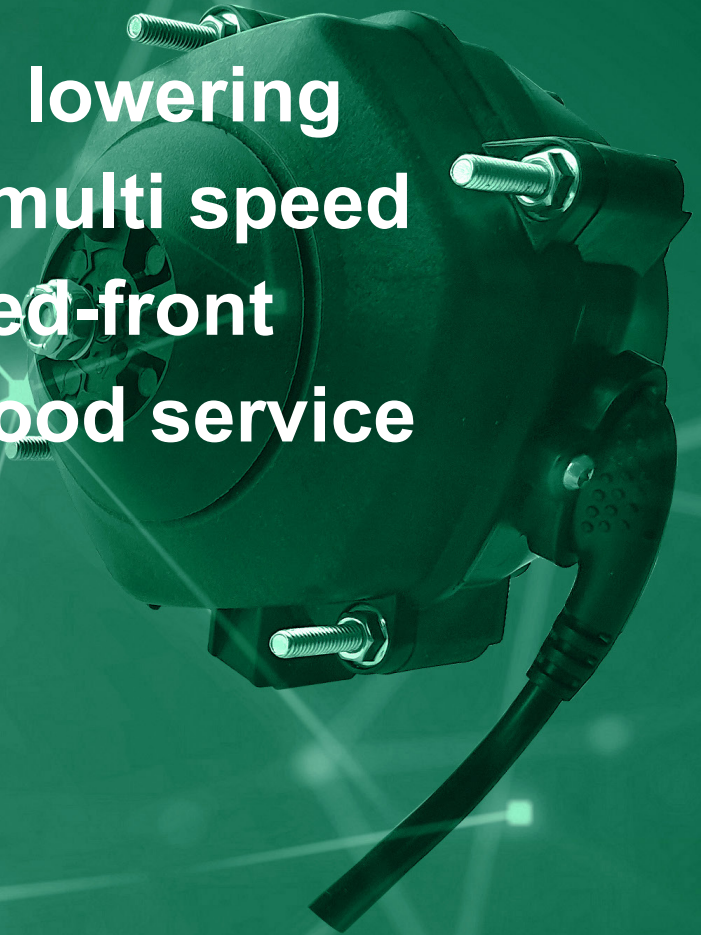

Three speed motors, like the Wellington **ECR[®] 2**, reduce power consumption and thermal losses in display cases. In closed-door cases, this is achieved by switching the fan to a lower speed when the evaporator is not in a cooling cycle.

In many closed-door display cases, the evaporator and condenser fans run continuously irrespective of the system's cooling cycle. This continuous operation is wasteful because:

- When the system is not cooling, no heat is being extracted from the case, so no airflow is required. Operating the motor during this time wastes energy. Additionally, all this power is being dissipated as heat inside the case, so even more power must be used by the compressor to extract it.
- Un-needed airflow during the non-cooling period increases heat transfer through the case walls. This results in faster warming, shorter compressor-off periods, and wasted energy.
- Unnecessary airflow during the non-cooling period increases drying out of exposed perishable products.

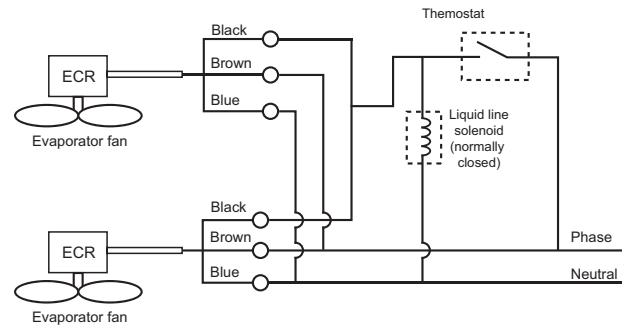

In other cases, the evaporator and condenser fans are switched off when the system is not cooling. This saves power but still leads to air stratification inside the case, allowing the temperature of products inside to vary unacceptably.

By using the ECR 2's three speed capability to reduce fan speed without turning it off, energy is saved while maintaining good temperature control. The ECR 2 is setup to run at reduced speed when not cooling, providing just enough airflow to prevent stratification.

ECR 2 three speed motor in a display case without a case controller. Fan speed is controlled by wiring the black control wire either into the liquid line solenoid (if a line power solenoid is present) or into the fan motor output of the case controller.

To do this, the ECR 2 motor should be wired so that the blue and brown wires are permanently connected to phase and neutral, and the black wire is connected to phase when the system is cooling and disconnected or connected to neutral when the system is not cooling.

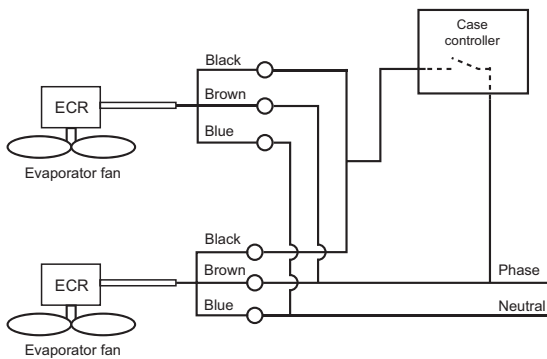

ECR 2 three speed motor in a display case with a case controller. The controller should be programmed for "fan off" when not in cooling cycle, so the motor can operate at a minimum speed.



Let's make the world better

From protecting the food supply to ensuring medicines remain safe, refrigeration systems are critical for modern life as we know it. Wellington exists to deliver trusted technology for the real world that solves our customers unique problems. We believe that by collaborating with our OEM partners and placing our technology in every location, we will ensure a sustainable future with safe foods, beverages, and medicines for our families and future generations. We invite you to learn more about how Wellington can partner with you and build a better world together.

Authors:

Sue Sieben, *Application Engineer*, Wellington Drive Technologies US, Inc.

Michael Young, *Regional Director*, Wellington Drive Technologies US, Inc.

About Wellington Drive Technologies Limited:

Wellington is a leading provider of IoT solutions, cloud-based fleet management platforms, energy-efficient electronic motors and connected refrigeration control solutions. It serves some of the world's leading food and beverage brands and refrigerator manufacturers and offers proximity-based marketing for Smart Cities to the Australian market. Wellington's services and products improve sales, decrease costs and reduce energy consumption. Headquartered in Auckland with a global reach, Wellington is listed on the New Zealand stock exchange under the ticker symbol NZ: WDT

©2020 Wellington Drive Technologies Limited.

Trademarks are (as applicable) 'TM' and © of Wellington Drive Technologies Limited. While all information in this document is believed by Wellington Drive Technologies Limited to be accurate and reliable, Wellington Drive Technologies Limited and its subsidiaries and affiliates and their directors, officers and employees are not responsible for any errors or omissions of any kind whatsoever, and to the maximum extent permitted at law, have no liability in tort, contract, or otherwise to any user and/or any third party.

E: info@wdtl.com www.wdtl.com



Saving energy and lowering product cost
with multi speed fan motors in
closed-front supermarket and food
service display cases

www.wdtl.com

WT9426_i3 07/20