

## Senturion PRI04 Proximity Probe



- Proximity Probe with built in driver.
- Fully compatible with API 670 systems.
- 2.5mm measurement range.
- Excellent linearity and stability.
- Suitable for operation up to +90 °C.
- Suitable for relative vibration and shaft position measurements.

Proximity probe systems are usually made up of a calibrated probe, extension cable and driver. The PRI04 proximity probe system is a fully integrated probe with all these elements contained in the probe body. Utilising the eddy current principle, this combination forms a tuned circuit with the target material and variations in probe face to target distance are detected in this circuit by the driver. This provides a linearised voltage output proportional to target gap with a nominal sensitivity of 7.87 mV/um and a range of up to 2.5 mm. This type of measurement system provides highly accurate (resolution typically less than one micro-meter) vibration and relative positional measurements, for harsh environments up to 90 °C.

The probe temperature range is limited to 90°C due to the integrated electronics and is therefore also suitable for most pumps, fans and hydroelectric generator vibration monitoring applications. Removing the need for the separate driver and associated housing provides a significant cost saving with no compromises in measurement accuracy. The fully integrated assembly also offers increased immunity to signal interference with the removal of the probe to driver connecting cable.

The probe offers cable lengths of 5 m or 10 m for connecting locally to the machine with the capability of driving up to 500m of cable to the connecting system without loss of accuracy.

**Specification**

Measurement Range: Standard Option	0.0 mm to 2.5 mm	Cable type:	3-wire 16/02 PE outer jacket 3.2 mm outer diameter
Linearity: (% of FS)	± 2%, -1.0 V to -19.0 V ± 5%, 0 °C to +90 °C @ -10.0V	Armoured option:	Stainless Steel Overbraid
Std Sensitivity:	7.87 V/mm (200 mV/mil) ± 1 %	Operating Temp Range:	-30 °C to +90 °C
Linear voltage range: Standard Option	-1.0 V to -19.0 V for 0.254 mm (10 mil) to 2.54 mm (100 mil)	Storage Temp Range:	-40 °C to +90 °C
Resolution:	<0.001 mm	Minimum target diameter:	16 mm
Frequency Response:	DC to 10 kHz	Effect of target curvature:	+2 % for shaft diameter 150 mm +5 % for shaft diameter 25 mm
Maximum Cable Length:	330 m based on 120 pF/m at <10 kHz and 500 um pk-pk. 3000 m based on 120 pF/m at <1 kHz and 500 um pk-pk.	Magnetic field effect:	<1 % at 110 mT
Reference Target Material:	ANSI 4140	Power supply range:	-16.0 Vdc to -28.0 Vdc Note: Output voltage is limited to 2.0 V below supply voltage when supply is < -21.5 V.
Probe tip diameter:	8.0 mm	Power supply: sensitivity	< 0.3 mVout / Vsupply
Probe tip material:	PPS 40 % Glass Filled	Power consumption:	3 mA typ, 7 mA max
Probe body material:	Stainless steel	Output impedance:	75 Ohms
Available probe body lengths:	70 mm to 150 mm M10 x 1.0 2.8 in to 5.9 in 3/8 UNF		

**Probe Mechanical Configuration**

**Straight Mount**

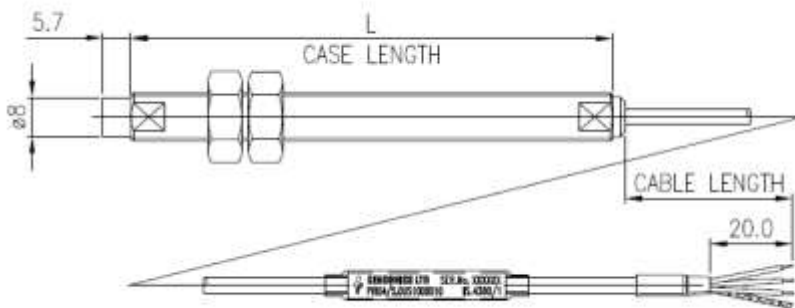

**Reverse Mount**

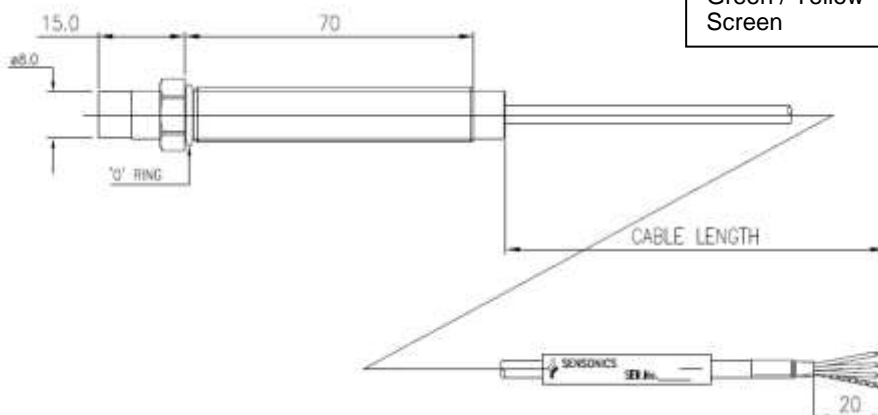

<b>Cable Connections</b>	
Red	-24.0 Vdc Supply
Blue	Signal Hi O/P
Green / Yellow	Signal Lo O/P
Screen	Isolated from case

**Probe Ordering Information**

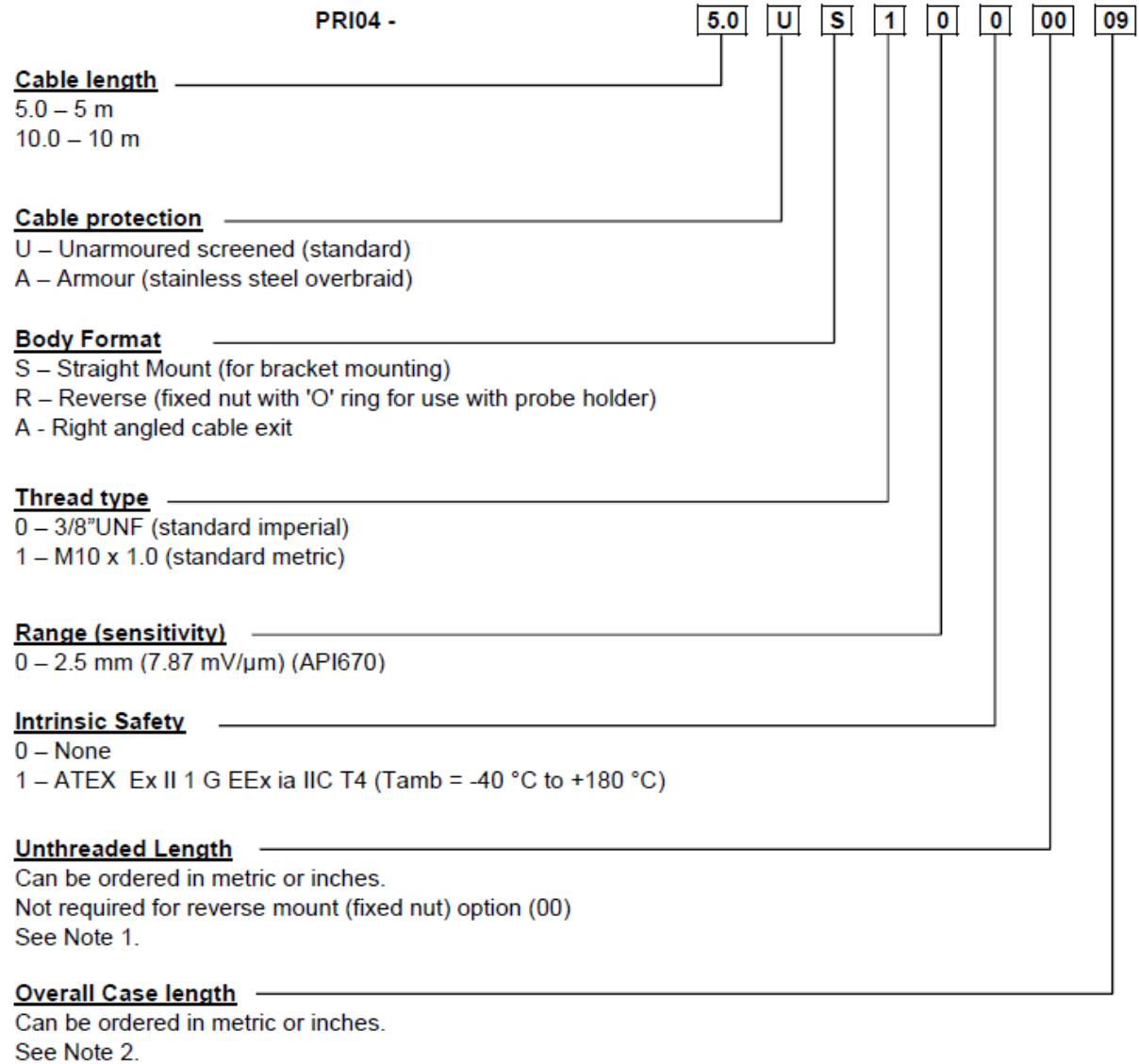

**Note 1 - Unthreaded Length Option**

**Imperial Case**

Unthreaded length must be at least 0.8 inches less than the case length. Order in increments of 0.1 in.  
Maximum unthreaded length: 5.1 in.  
Minimum unthreaded length: 0.0 in.  
Example: 04 = 0.4 in.

**Metric Case**

Unthreaded length must be at least 20 mm less than the case length. Order in increments of 10 mm.  
Maximum unthreaded length: 130 mm.  
Minimum unthreaded length: 0 mm.  
Example: 06 = 60 mm.

**Note 2 - Overall Case Length Option**

**Imperial Case**

Order in increments of 0.1 in.  
Maximum case length: 5.9 in  
Minimum case length: 2.8 in  
Example: 44 = 4.4 in

**Metric Case**

Order in increments of 10 mm.  
Maximum length: 150 mm.  
Minimum length: 70 mm.  
Example: 09 = 90 mm.



**SENSONICS**

**Sensonics Ltd**  
Northbridge Road  
Berkhamsted  
Herts, HP4 1EF  
United Kingdom  
Tel: +44 (0)1442 876833  
Fax: +44 (0)1442 876477  
[www.sensonics.co.uk](http://www.sensonics.co.uk)