

COMBINED



PELICAN 6 P



A
R
N
E
G



EFFICIENCY COMBINED WITH STYLE.

Characterised by exceptional energy efficiency and extremely reliable technology, the **Pelican 6P** combined cabinet for frozen foods fully satisfies the needs of all kinds of store. Versatile and customisable, it provides a solution that adapts perfectly to all settings.

- **Energy efficiency**
- **Reduced consumption**
- **Advanced performance**
- **Top-quality, reliable technology**





MAXIMUM PRODUCT VISIBILITY.

Design, lighting and the distribution of internal space have all been chosen to optimise product visibility and enhance presentation. Excellent ergonomics ensure easy access to the products on display while offering customers a premium shopping experience and facilitating the work of store personnel.

FREEDOM TO CUSTOMISE.

In addition to its modern, linear styling, Pelican 6P also offers extensive customisation options thanks to a range of front panels with painted, laminated or wood finishes. Every store can therefore find the ideal style solution for its own interior décor.





- Excellent load capacity
- Large display surface
- Different lengths available

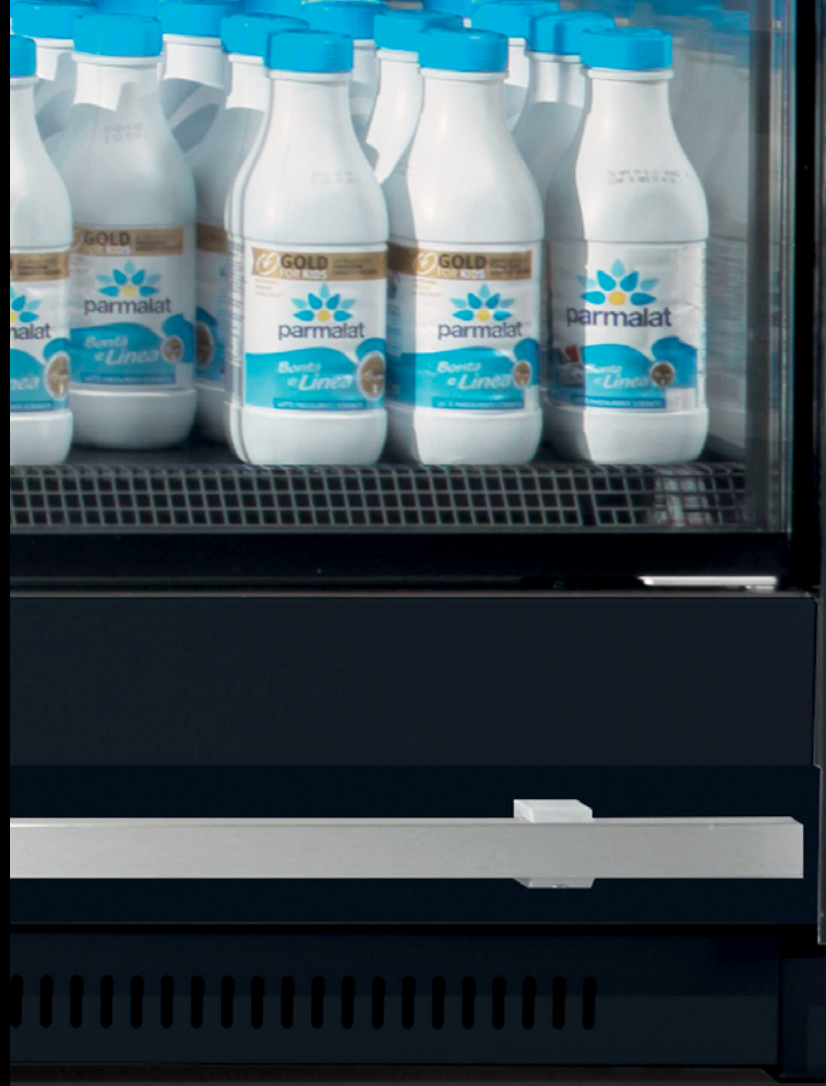

1



2



3



4

ACCESSORIES

1 - Rectangular bumper

2 - PVC bumper

3 - LED light

4 - Bottom grilles

PELICAN 6P COMB-C BT-BT V1E LINEARE R

| | | | | | | | | | | | | |
|---------------------------------|------------------|-----------|------------|-----------|------------------|-----------|------------|-----------|------------------|-----------|------------|-----------|
| Length without side panels (mm) | 1875 | | | | 2500 | | | | 3750 | | | |
| Height (cm) | 205 | | 216 | | 205 | | 216 | | 205 | | 216 | |
| Height of glass front | G3 | G4 | G3 | G4 | G3 | G4 | G3 | G4 | G3 | G4 | G3 | G4 |
| Temperature class | 3L1 | | | | • | | | | • | | | |
| Preservation temperature (°C) | -22/-25 | | | | • | | | | • | | | |
| Horizontal display area* (m²) | 4,53 | | | | 6,05 | | | | 9,07 | | | |
| Energy class** | A T G D | | | | A T G D | | | | A T G D | | | |

*Value referred to illustrated configurations.

**The energy class may vary depending on the product configuration.

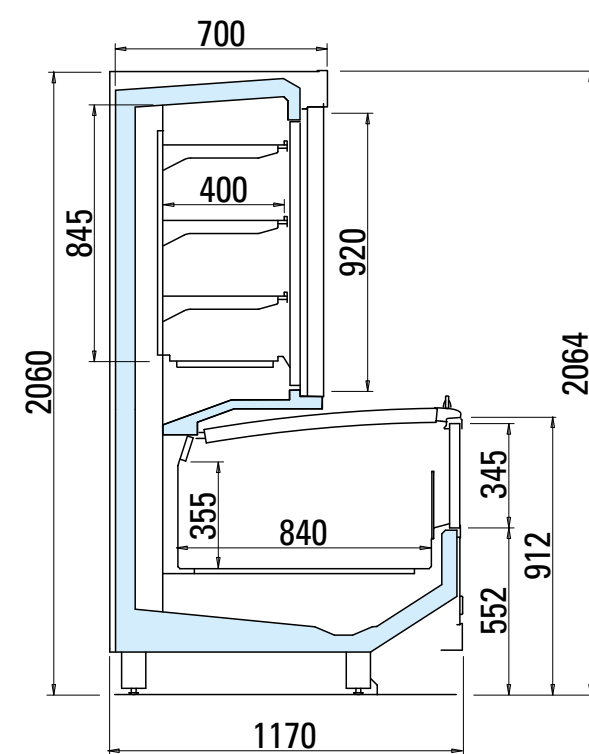

H205 G3

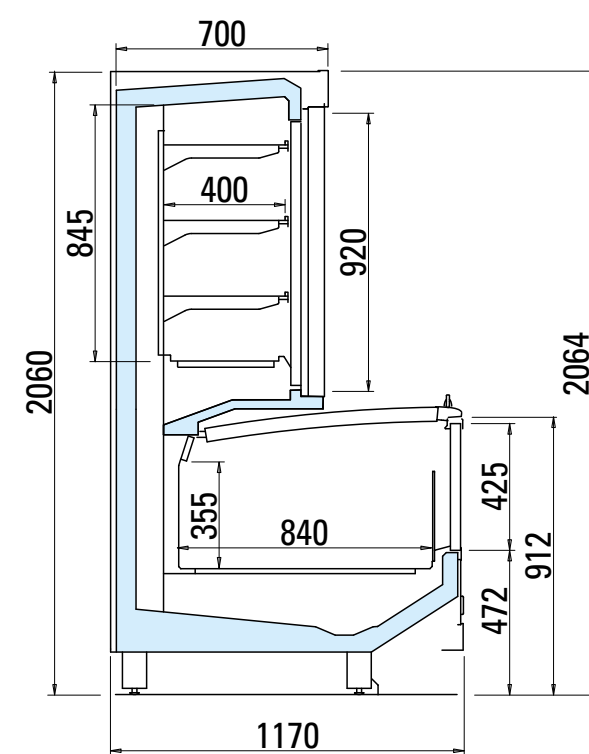

H205 G4

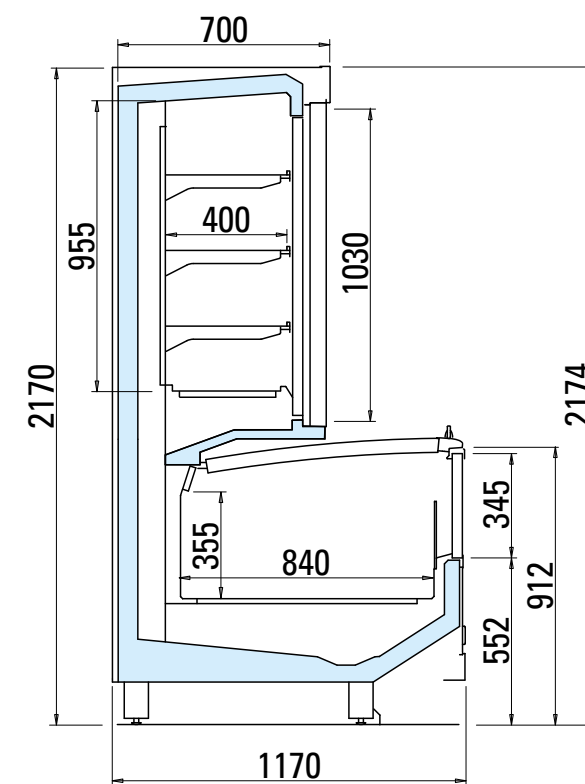

H216 G3

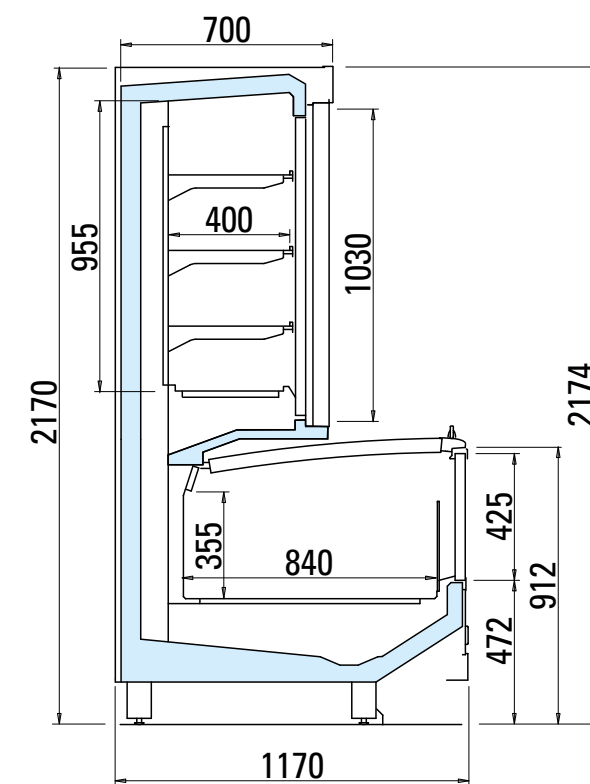

H216 G4

PELICAN 6P COMB-C BT-BT V2E LINEARE R

| | | | | | | | | | | | | |
|---------------------------------|-------------------------|-----------|------------|-----------|-------------------------|-----------|------------|-----------|-------------------------|-----------|------------|-----------|
| Length without side panels (mm) | 1875 | | | | 2500 | | | | 3750 | | | |
| Height (cm) | 205 | | 216 | | 205 | | 216 | | 205 | | 216 | |
| Height of glass front | G3 | G4 | G3 | G4 | G3 | G4 | G3 | G4 | G3 | G4 | G3 | G4 |
| Temperature class | 3L1 | | | | • | | | | • | | | |
| Preservation temperature (°C) | -22/-25 | | | | • | | | | • | | | |
| Horizontal display area* (m²) | 4,53 | | | | 6,05 | | | | 9,07 | | | |
| Energy class** | A T G E | | | | A T G E | | | | A T G E | | | |

*Value referred to illustrated configurations.

**The energy class may vary depending on the product configuration.

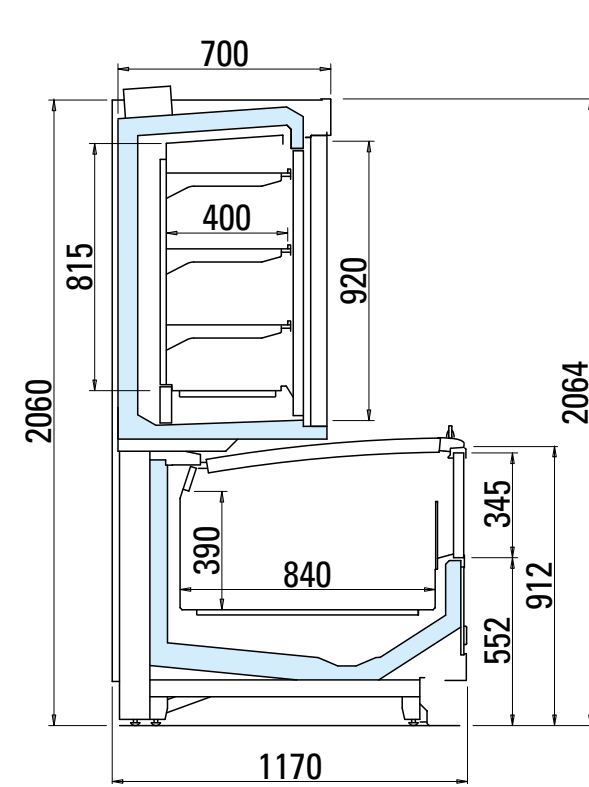

H205 G3

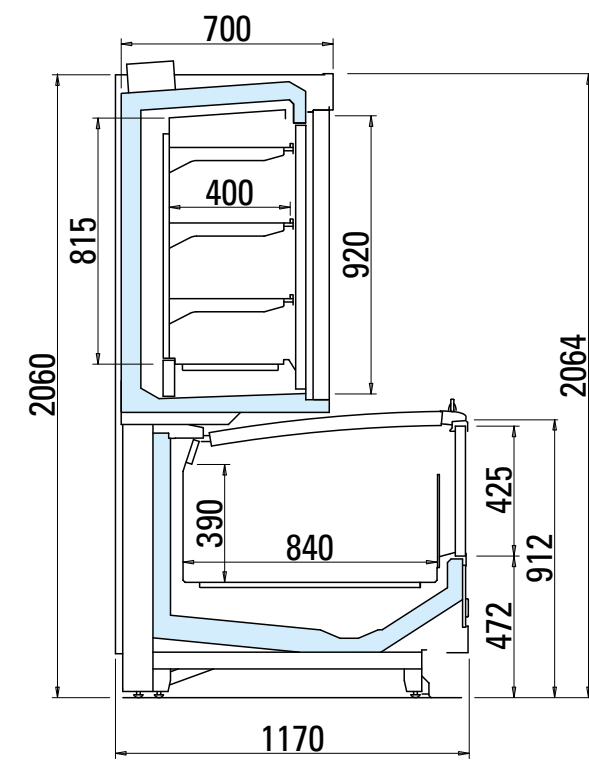

H205 G4

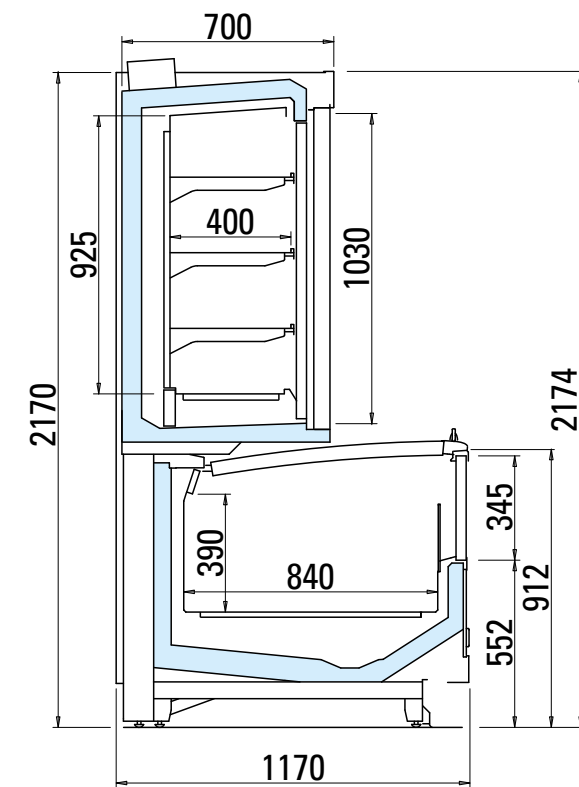

H216 G3

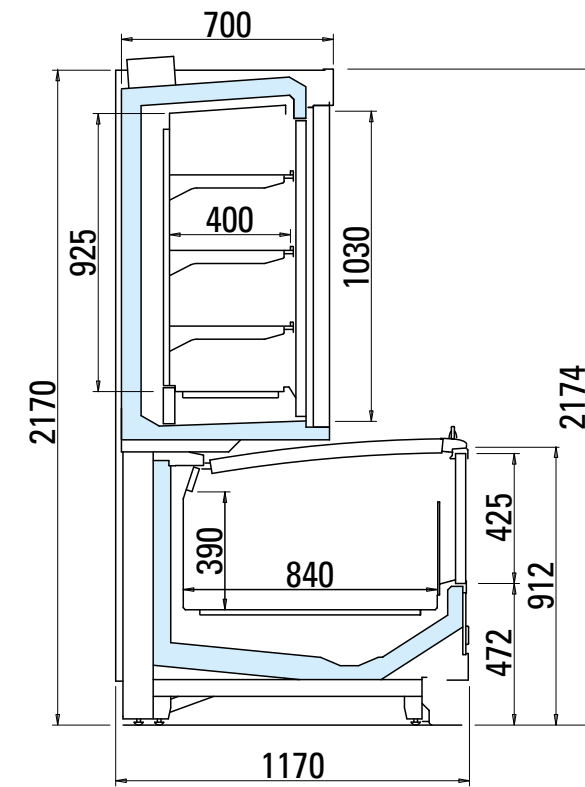

H216 G4

PELICAN 6P COMB-C BT-BT V2E TESTATA R

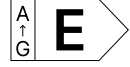
| | | | | | |
|-------------------------------|---------|-------------------------------------------------------------------------------------|-----------|------------|-----------|
| Overall length (mm) | | 2352 | | | |
| Height (cm) | | 205 | | 216 | |
| Height of glass front | | G3 | G4 | G3 | G4 |
| Temperature class | 3L1 | • | | | |
| Preservation temperature (°C) | -22/-25 | • | | | |
| Horizontal display area* (m²) | | 3,83 | | | |
| Energy class** | |  | | | |

*Value referred to illustrated configurations. **The energy class may vary depending on the product configuration.

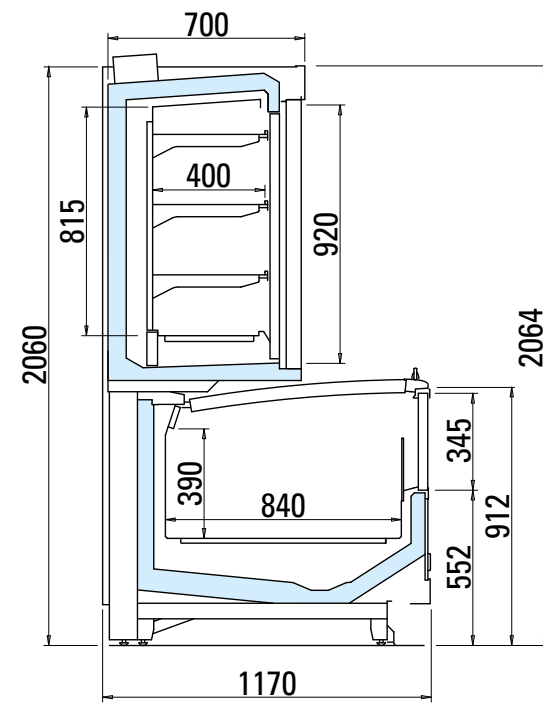
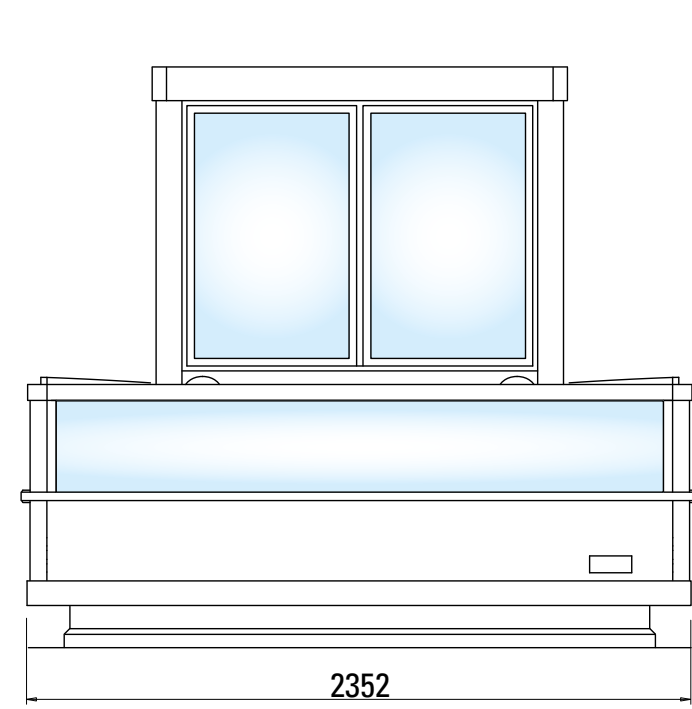

H205 G3

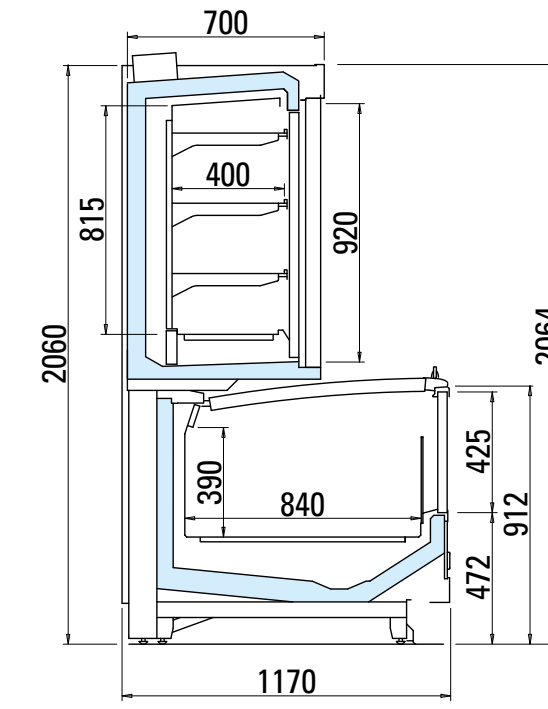
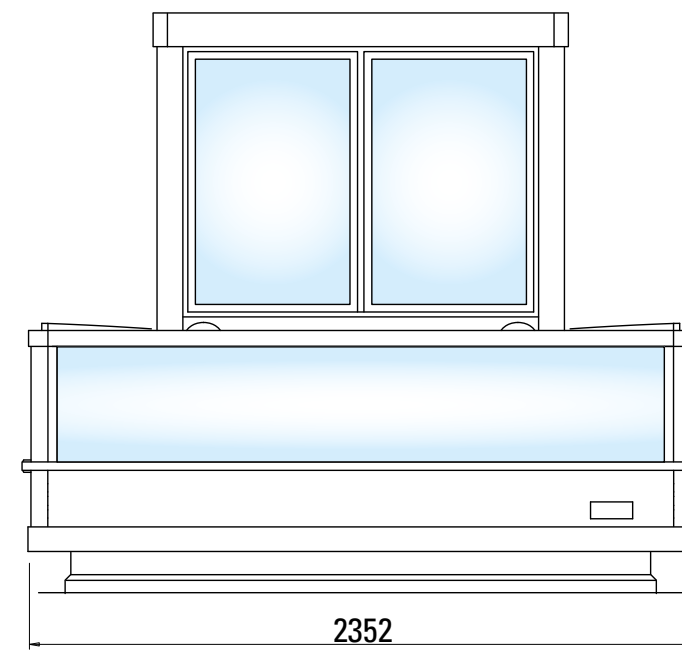

H205 G4

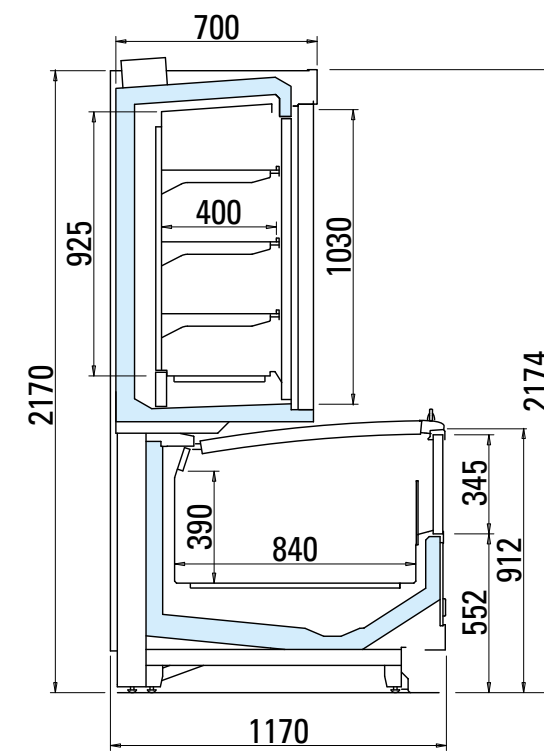
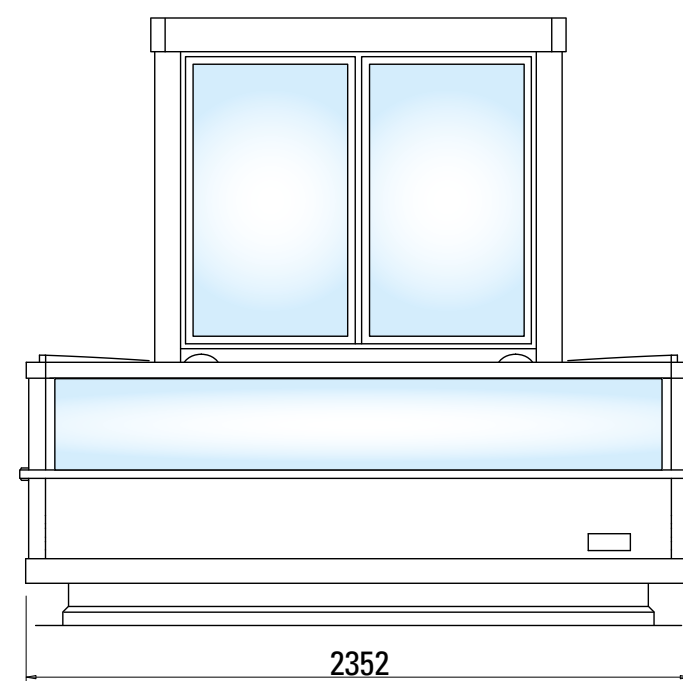

H216 G3

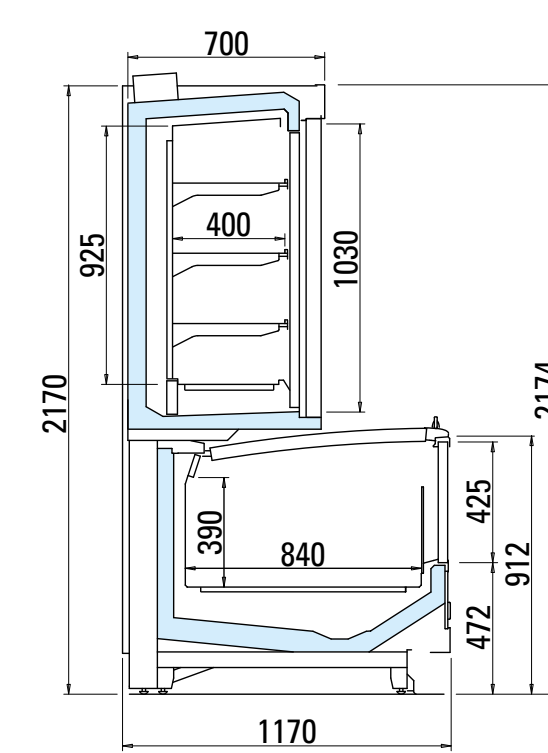
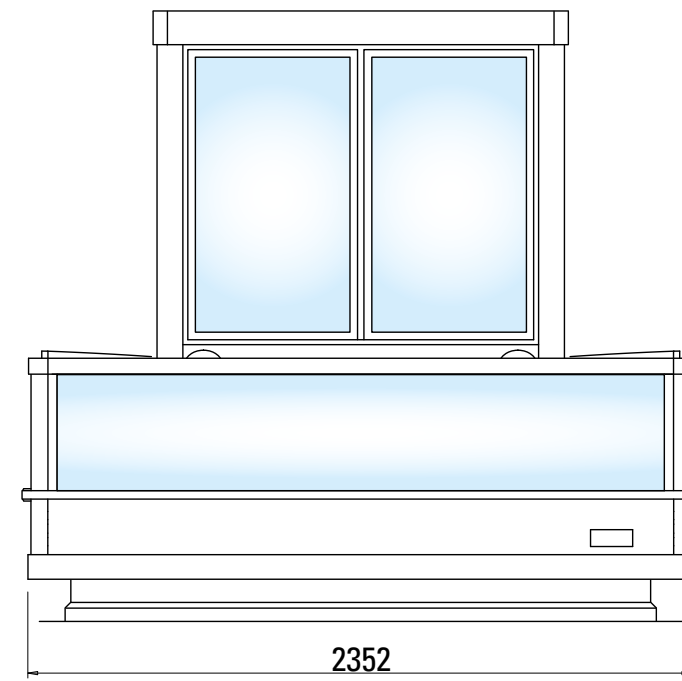

H216 G4

ED. 01 - 31/07/2024

arneg

WWW.ARNEG.COM



Arneg follows a policy of continuous improvement and reserves the right to update this document at any time without prior notice.