

SERVE-OVER COUNTER



# LAGUNA



A  
R  
N  
E  
G

# THE DESIGN OF FRESHNESS.

Freshness, hygiene and versatility.

**Laguna** is the counter that showcases product quality and adapts to the demands of each individual store, from large supermarkets to fish shops with smaller spaces. Flexible and attractive, Laguna displays and stores all kinds of fish perfectly.



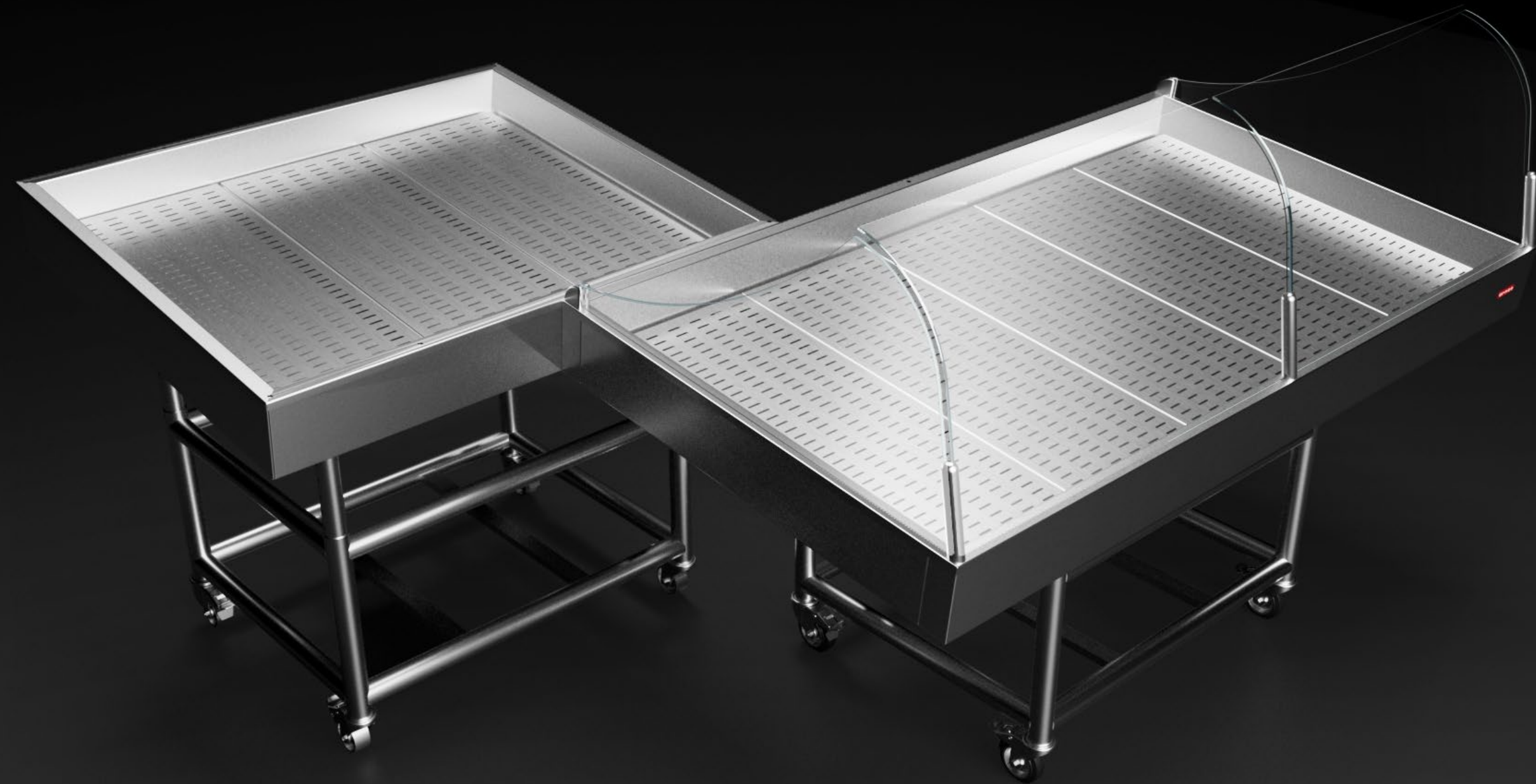

# QUALITY PLUS VERSATILITY.

Available in unrefrigerated ice bed or ice bed with basin cooling coil, with evaporator and stainless steel tray versions, this modular structure counter can be customised and installed alongside other Arneg solutions.

- Large display surface
- Maximum transparency
- Modern, minimalist design



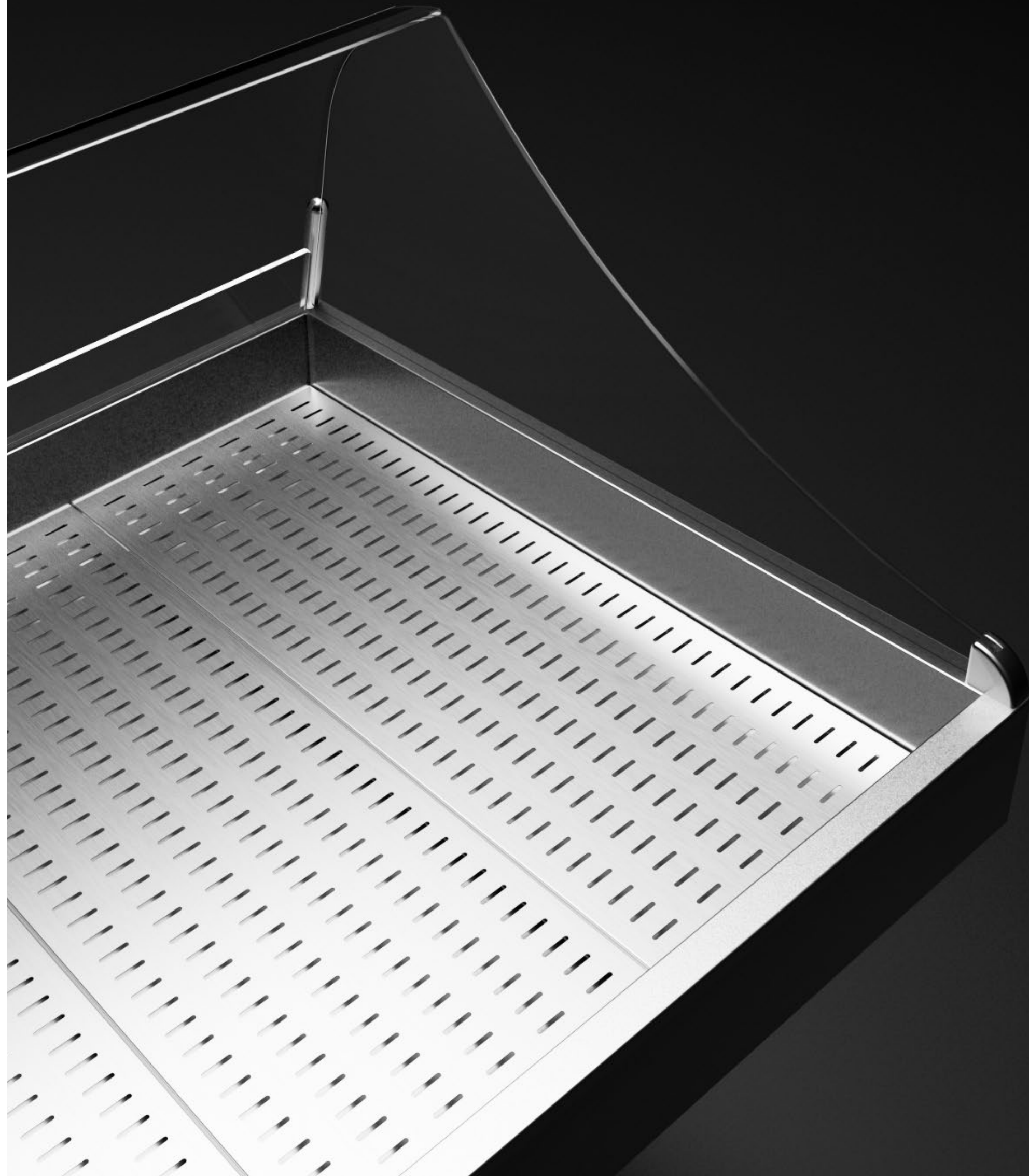

The choice of the finest materials on the market is a distinctive feature of all Arneg displays. In particular, the choice of AISI 316 stainless steel is proof of a constant commitment to creating products that assure the highest standards of durability, hygiene and food safety.

**STAINLESS-STEEL  
HYGIENE.**

# ERGONOMICS AT WORK.

With a variable tilt, variable height basin, the counter adapts to display requirements and operator tasks. Rubber wheels make moving the counter around easy, while removable tempered glass panels make cleaning inside simpler.



LAGUNA VETR-FH TN S LINEARE R

Length without side panels (mm)		<b>625</b>	<b>937</b>	<b>1250</b>	<b>1875</b>	<b>2500</b>
Temperature class	<b>3 M1</b>	•	•	•	•	•
Preservation temperature (°C)	<b>0 / +2</b>	•	•	•	•	•
Horizontal display area* (m <sup>2</sup> )		0,44	0,66	0,88	1,32	1,76

\*Model not subject to energy labelling.

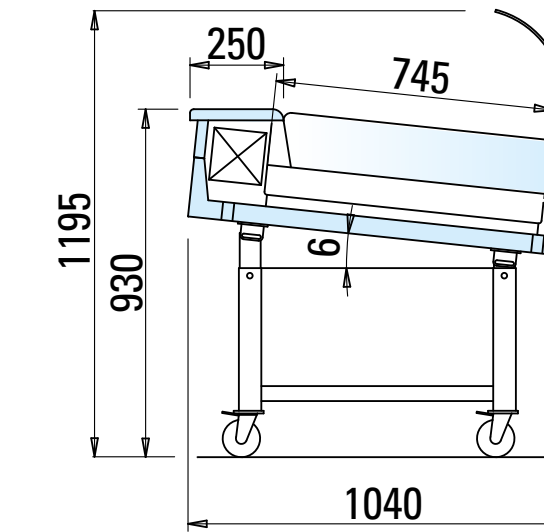

LAGUNA VETR-FH TN SCC LINEARE R

Length without side panels (mm)		<b>625</b>	<b>1250</b>	<b>1875</b>	<b>2500</b>
Temperature class	<b>3 M1</b>	•	•	•	•
Preservation temperature (°C)	<b>0 / +2</b>	•	•	•	•
Horizontal display area* (m <sup>2</sup> )		0,58	1,15	1,73	2,3

\*Model not subject to energy labelling.

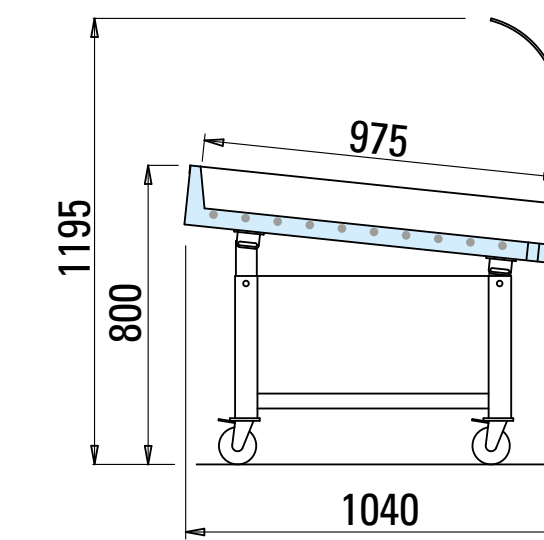

## LAGUNA VETR-FH TN S LINEARE I

Length without side panels (mm)		<b>625</b>	<b>937</b>	<b>1250</b>	<b>1875</b>	<b>2500</b>
Temperature class	<b>3 M1</b>	•	•	•	•	•
Preservation temperature (°C)	<b>0 / +2</b>	•	•	•	•	•
Refrigerant	<b>R290</b>	•	•	•	•	•
Horizontal display area* (m <sup>2</sup> )		0,44	0,66	0,88	1,32	1,76

\*Model not subject to energy labelling.

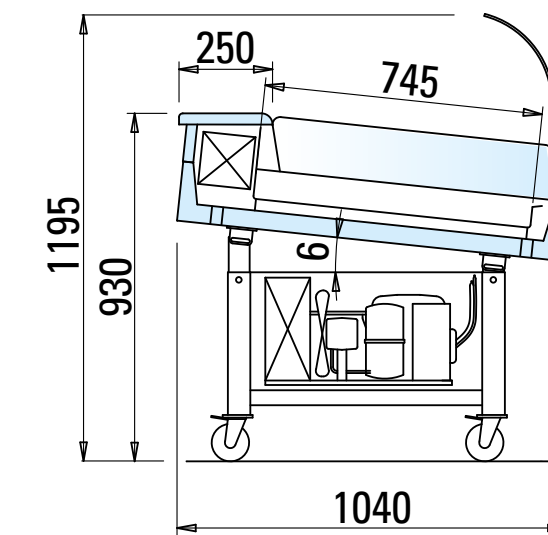

## LAGUNA VETR-FH TN SCC LINEARE I

Length without side panels (mm)		<b>1250</b>	<b>1875</b>	<b>2500</b>
Temperature class	<b>3 M1</b>	•	•	•
Preservation temperature (°C)	<b>0 / +2</b>	•	•	•
Refrigerant	<b>R290</b>	•	•	•
Horizontal display area* (m <sup>2</sup> )		1,15	1,73	2,3

\*Model not subject to energy labelling.

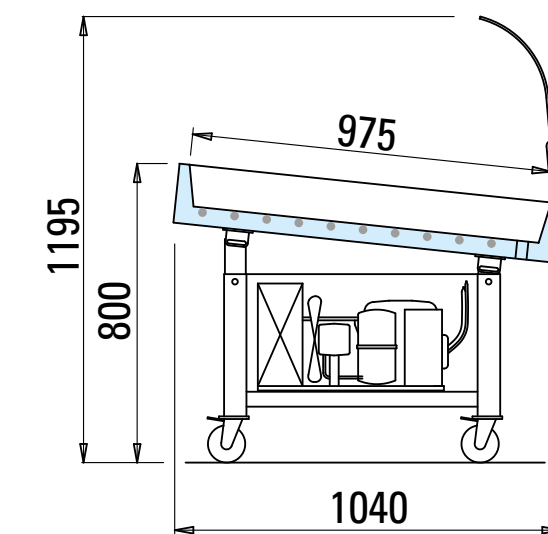



ED. 00 -20/10/2023

**arneg**<sup>®</sup>

[WWW.ARNEG.COM](http://WWW.ARNEG.COM)



Arneg follows a policy of continuous improvement and reserves the right to update this document at any time without prior notice.