

SERVE-OVER



HALIFAX



A
R
N
E
G

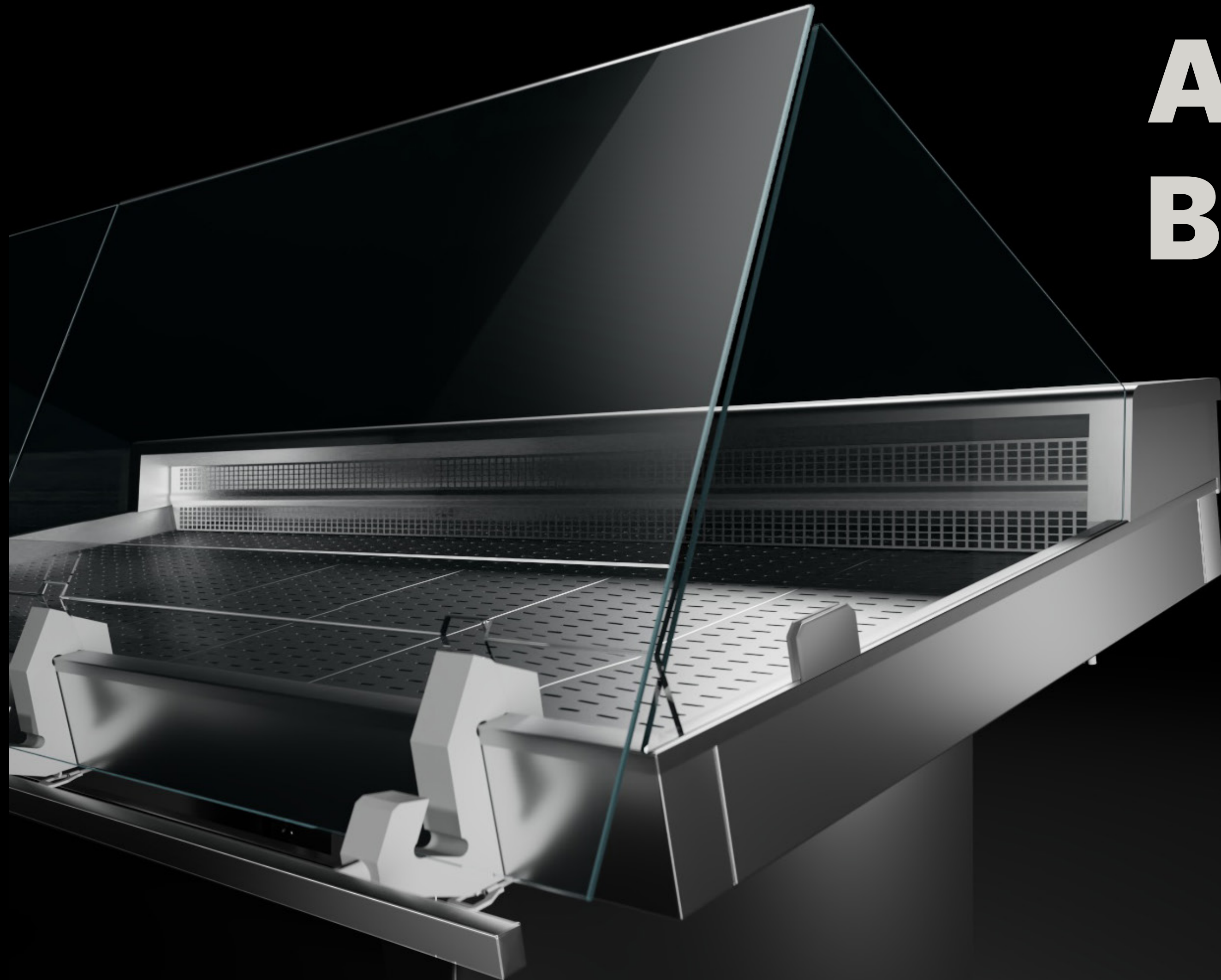

FRESHNESS AS NEVER SEEN BEFORE.

Specially designed to present fish in all its freshness, the **Halifax** fish counter combines minimalist form with maximum visibility to offer customers a shopping experience like never before.

High performance, ergonomic design and amazing versatility come together in this counter to add value to medium and large stores alike.

QUALITY THAT STANDS OUT.

Thanks to careful design and the elimination of all visual barriers, Halifax counters boast excellent product presentation as well as a high level of protection for the fish on display. All-round visibility adds to the attraction of these counters, focusing attention on the quality of the offering and facilitating customer choice.





Halifax counters come with a non-refrigerated ice bed, an ice bed with basin cooling coil or in a refrigerated version with evaporator.

They therefore respond to all functional requirements and are the perfect choice for selling all varieties of fresh fish, shellfish and seafood.

**ICY
VERSATILITY.**

STAINLESS-STEEL HYGIENE.

Special materials like AISI 316 stainless steel guarantee the hygienic conditions necessary for the sale of highly perishable food products. In addition to conforming to the strictest technical standards, this design solution demonstrates close attention to food safety and human health.

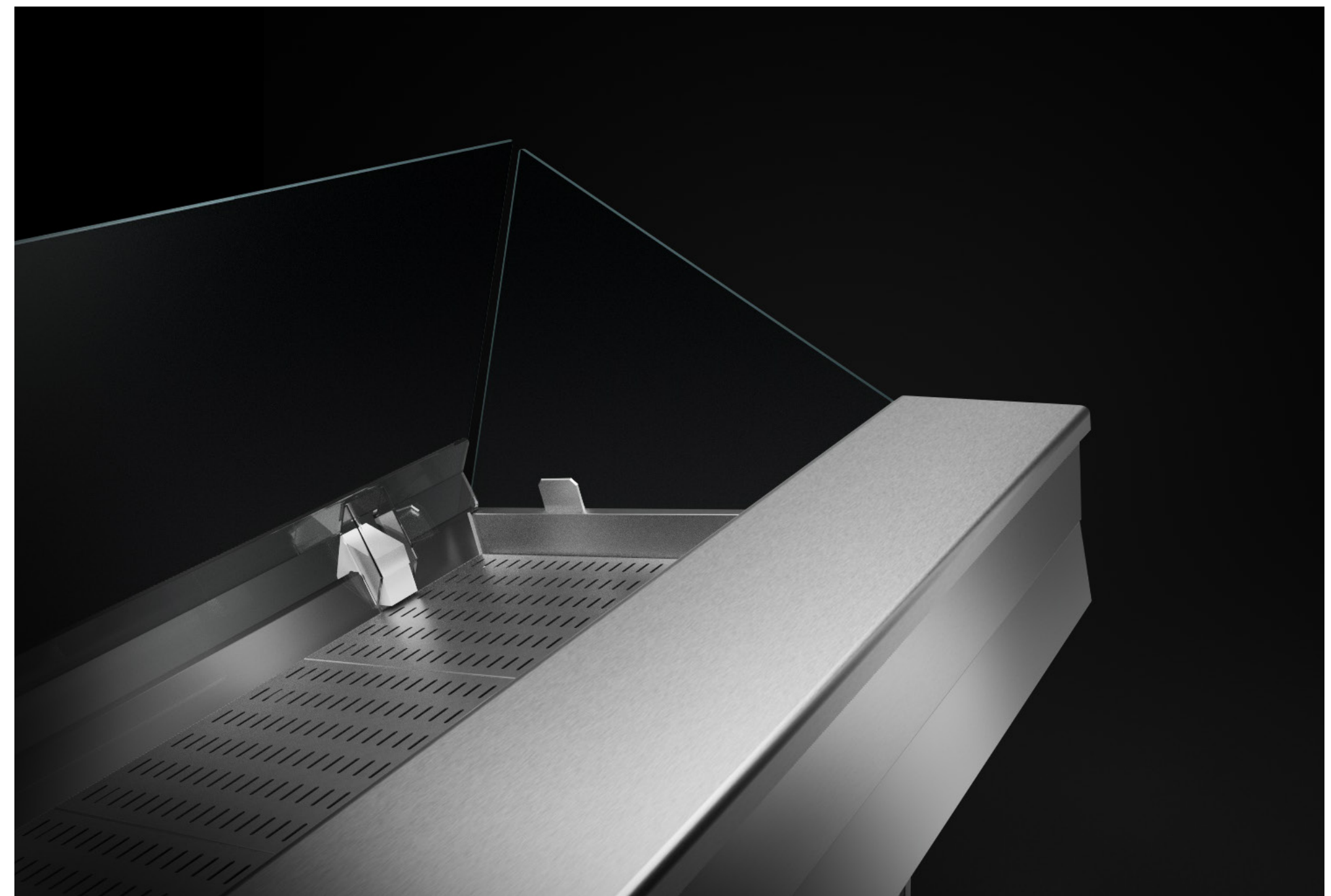
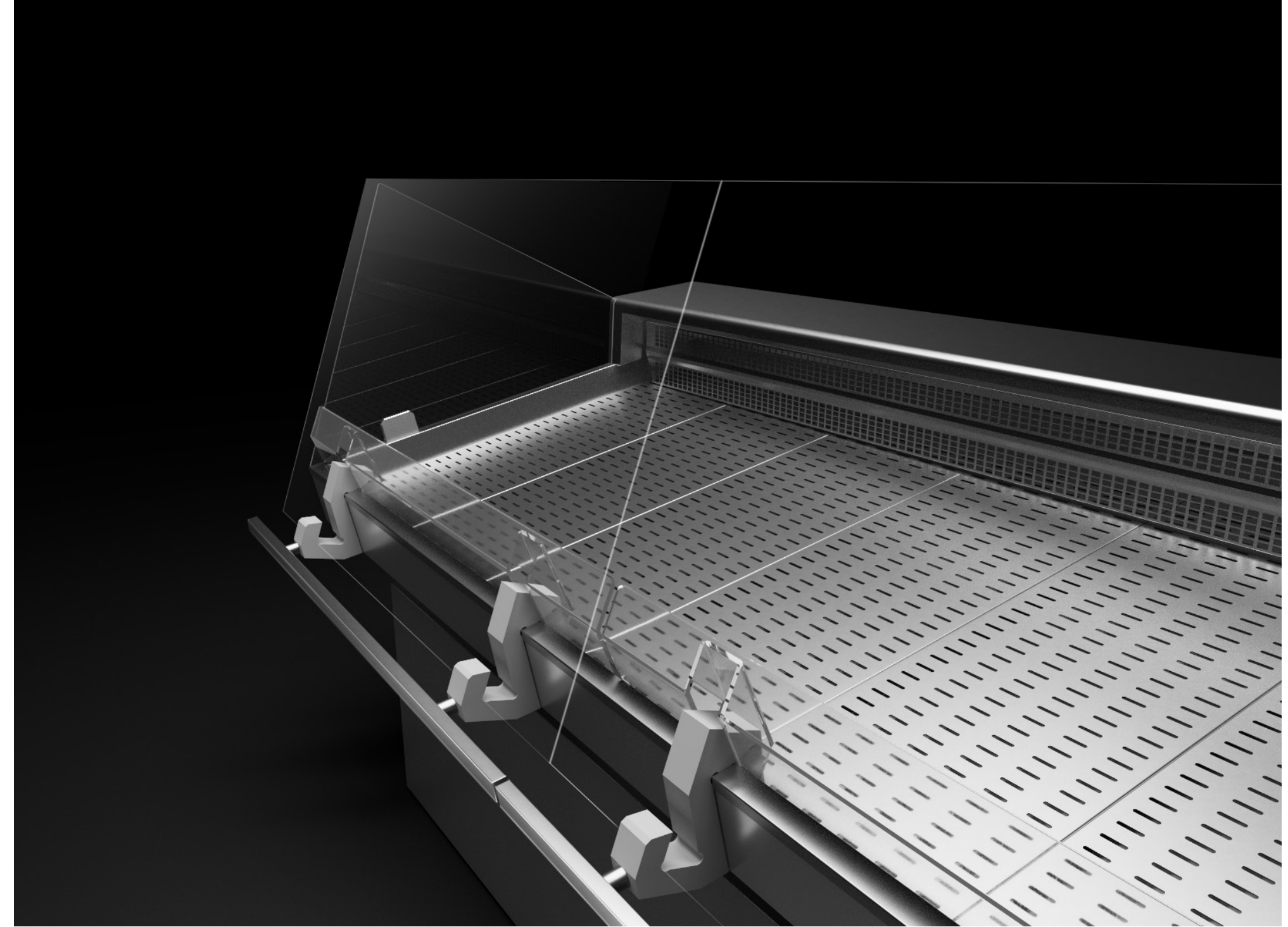

SMARTER CLEANING.

Ergonomics is central to Arneg research and to the development of counters that make operators' lives easier.

The front and side glasses of Halifax counters can be removed easily and safely to speed up the cleaning of internal parts.

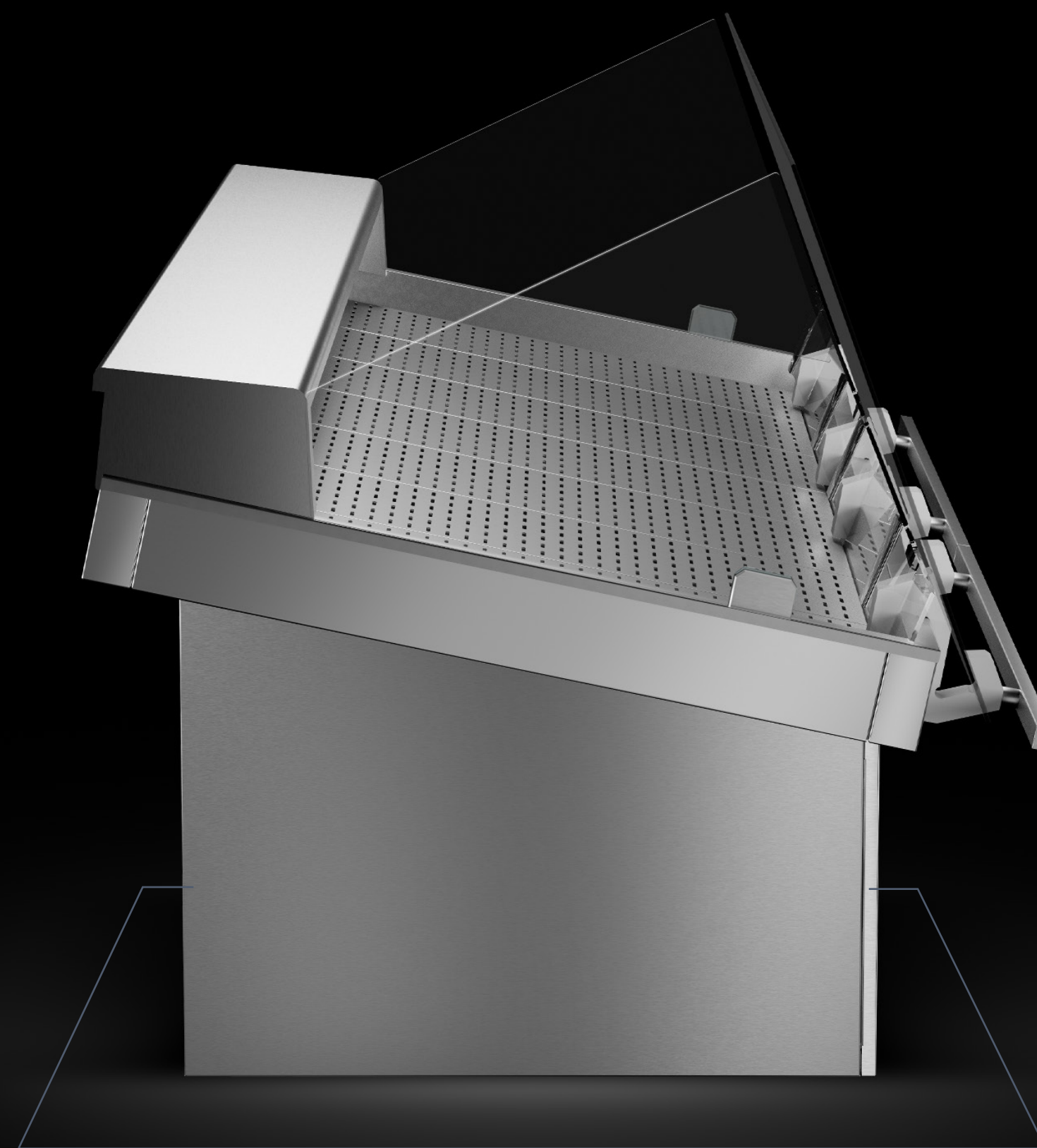

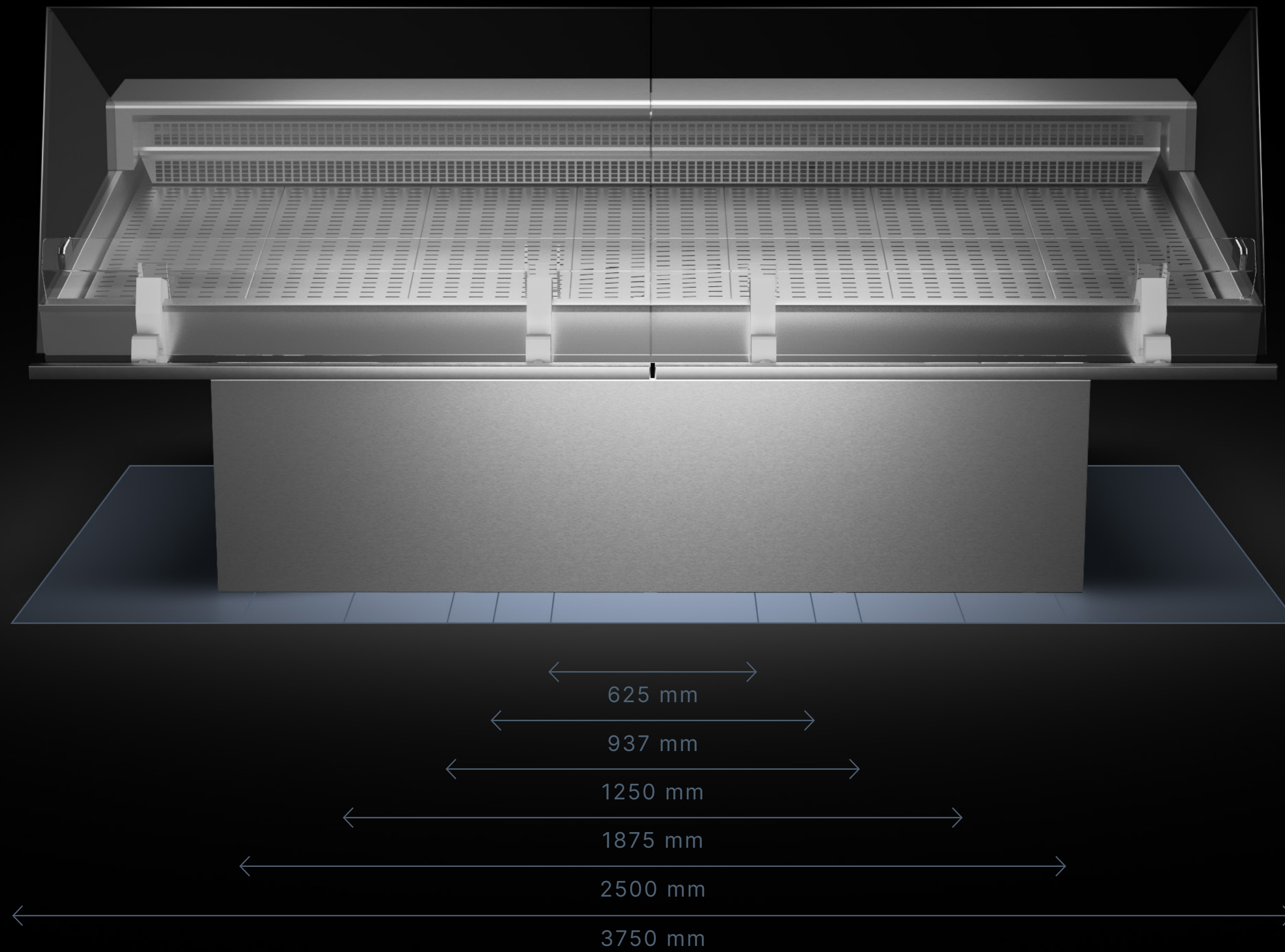

This specialist fresh fish counter adapts to the needs of all stores thanks to a range of lengths between 625 and 3750 mm.

HALIFAX VETR-FH TN S LINEARE R

Length without side panels (mm)		625	937	1250	1875	2500	3750
Temperature class	3 M1	•	•	•	•	•	•
Preservation temperature (°C)	0/+2	•	•	•	•	•	•
Horizontal display area (m ²)		0,37	0,59	0,81	1,29	1,7	2,58

Model not subject to energy labelling.

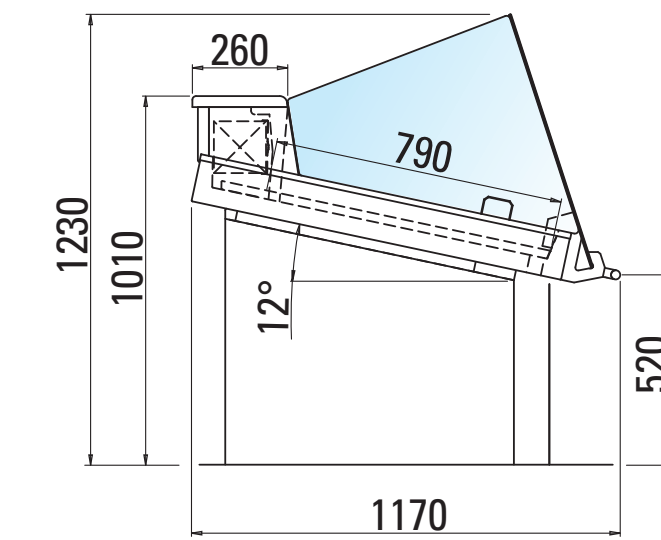

HALIFAX VETR-FH TN SCC LINEARE R

Length without side panels (mm)		625	937	1250	1875	2500	3750
Temperature class	3 M1	•	•	•	•	•	•
Preservation temperature (°C)	0/+2	•	•	•	•	•	•
Horizontal display area (m ²)		0,48	0,76	1,05	1,62	2,19	3,33

Modèle non soumis à l'étiquetage énergétique.

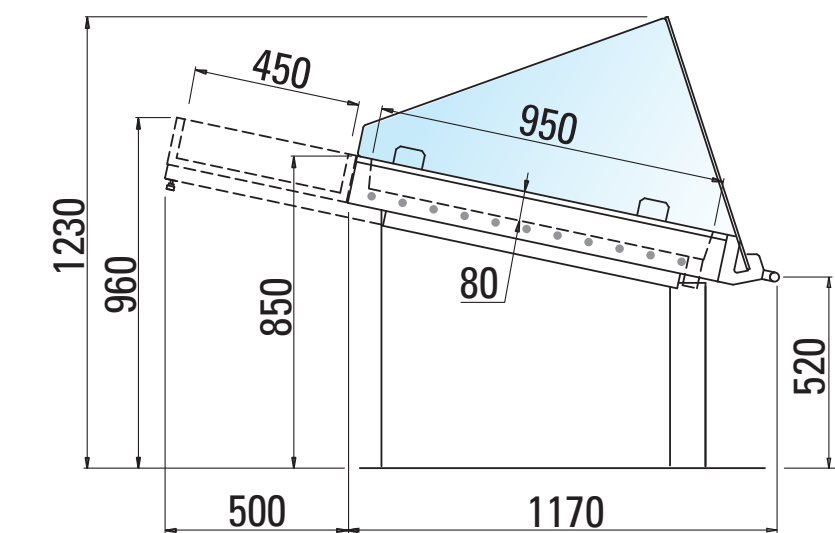

ED. 01 - 28/07/2023



WWW.ARNEG.COM



Arneg follows a policy of continuous improvement and reserves the right to update this document at any time without prior notice.