

The Planet

SAN JOSE

The Planet

A Cosmic Observatory Hovering in an Idyllic Park

The PLANET sculpture is a 109 foot diameter spherical mirror representing the Earth.

It reflects hundreds of square miles, creating a microcosm of land, rivers, ocean, sky, stars and city lights. The large Earth sphere is supported 15 feet overhead by a 30 foot diameter spherical mirror representing the Moon in true proportion.

The sculpture's total height is 124 feet. It's footprint is just 12 feet diameter.



Looking down from an airplane you see the reflection of your plane flying through the sky.

EARTH : MOON

SUN : EARTH

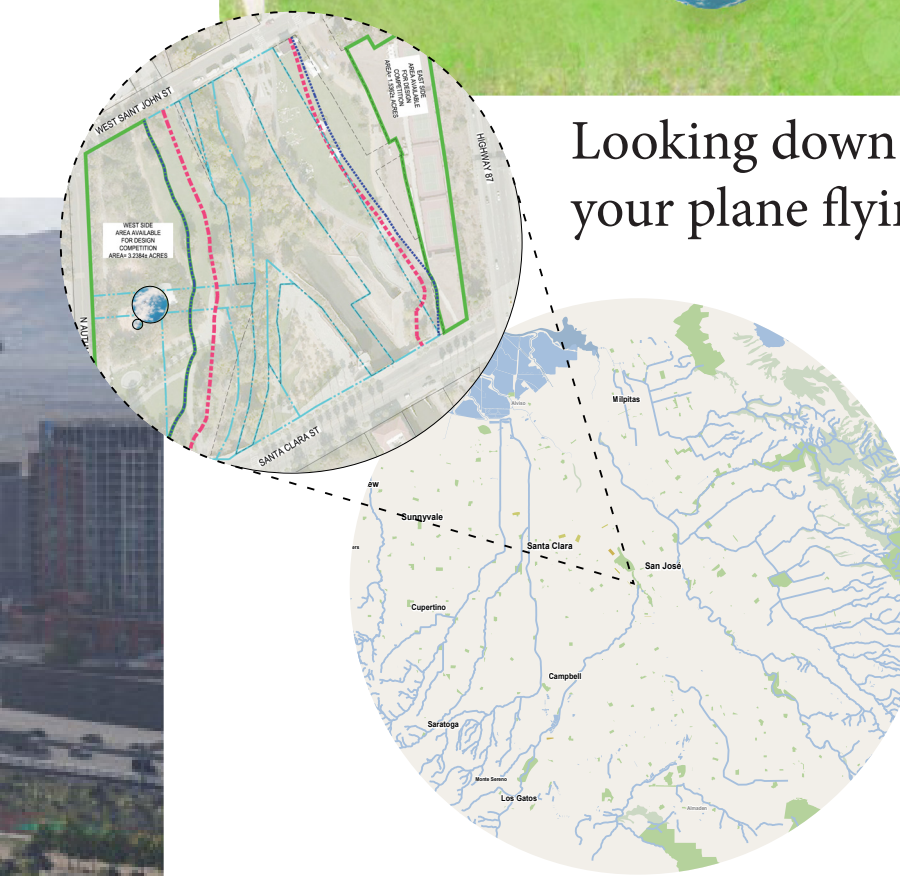
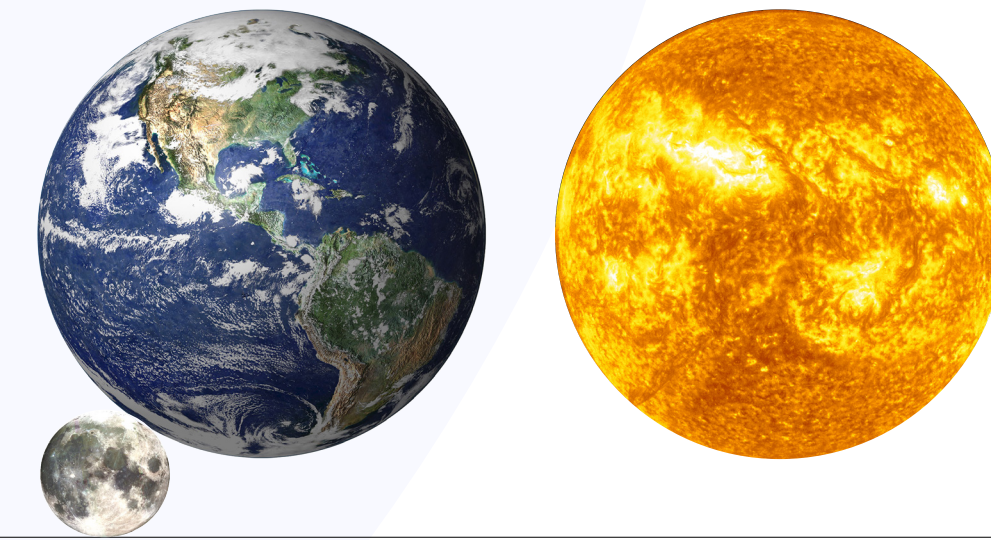

The panoramic image in the PLANET is optically high-resolution and deeply three-dimensional.

To enhance the beauty of its reflection the sculpture is set in an open lawn, a glade in a forest of many tree species. The setting is a living exhibition of the diversity of nature.

The 109 foot sphere has a dual identity, it also represents the Sun in true proportion to a 1 foot diameter spherical mirror Earth resting on the lawn.



EARTH

MOON

EARTH

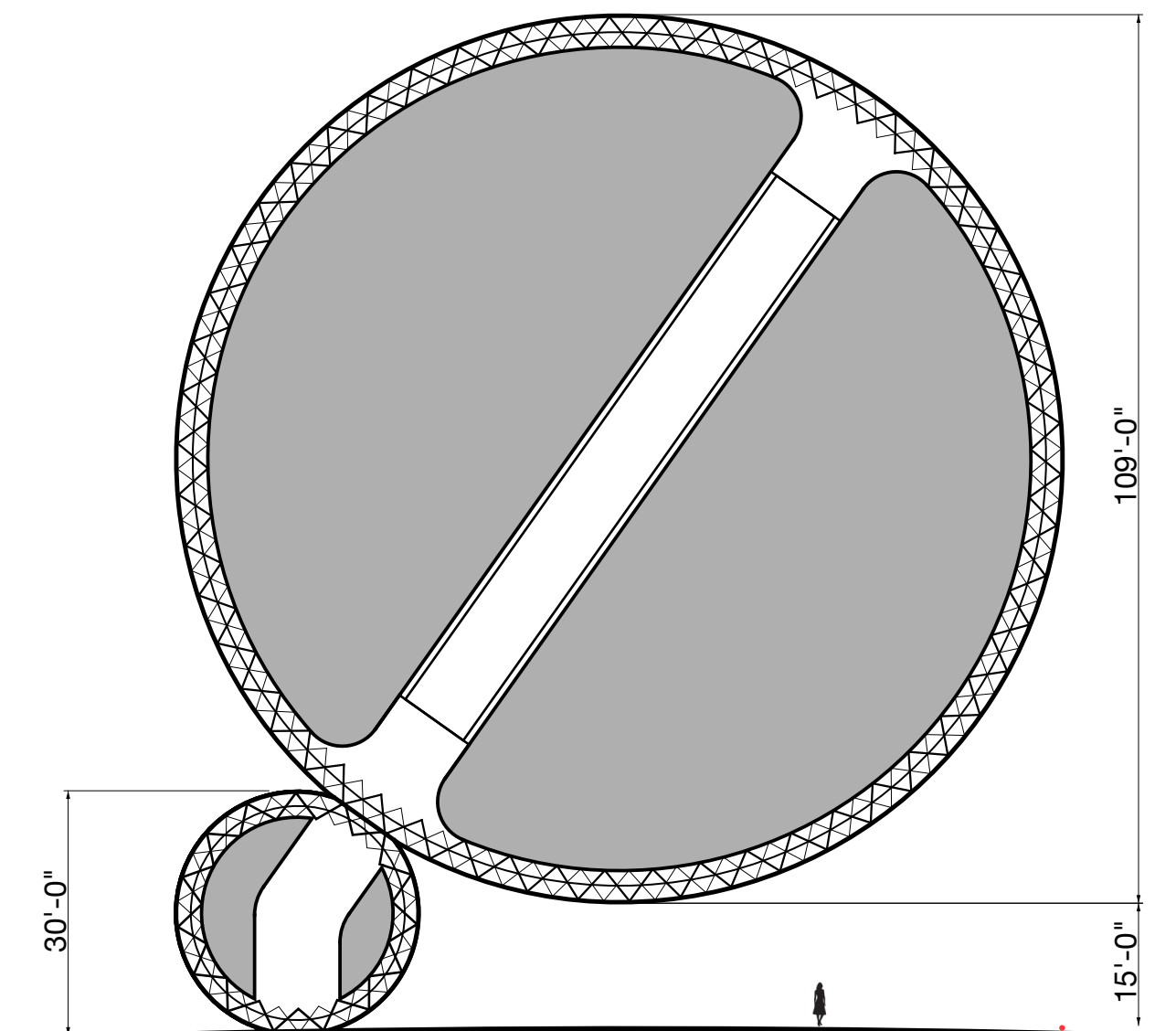

The two large spheres are made of curved stainless steel hexagons attached to a geodesic-like frame structure. The structure is supported by a robust core that is, in turn, anchored to a massive foundation hidden underground. The one foot diameter sphere is solid stainless steel and secured by a shaft in the ground.