

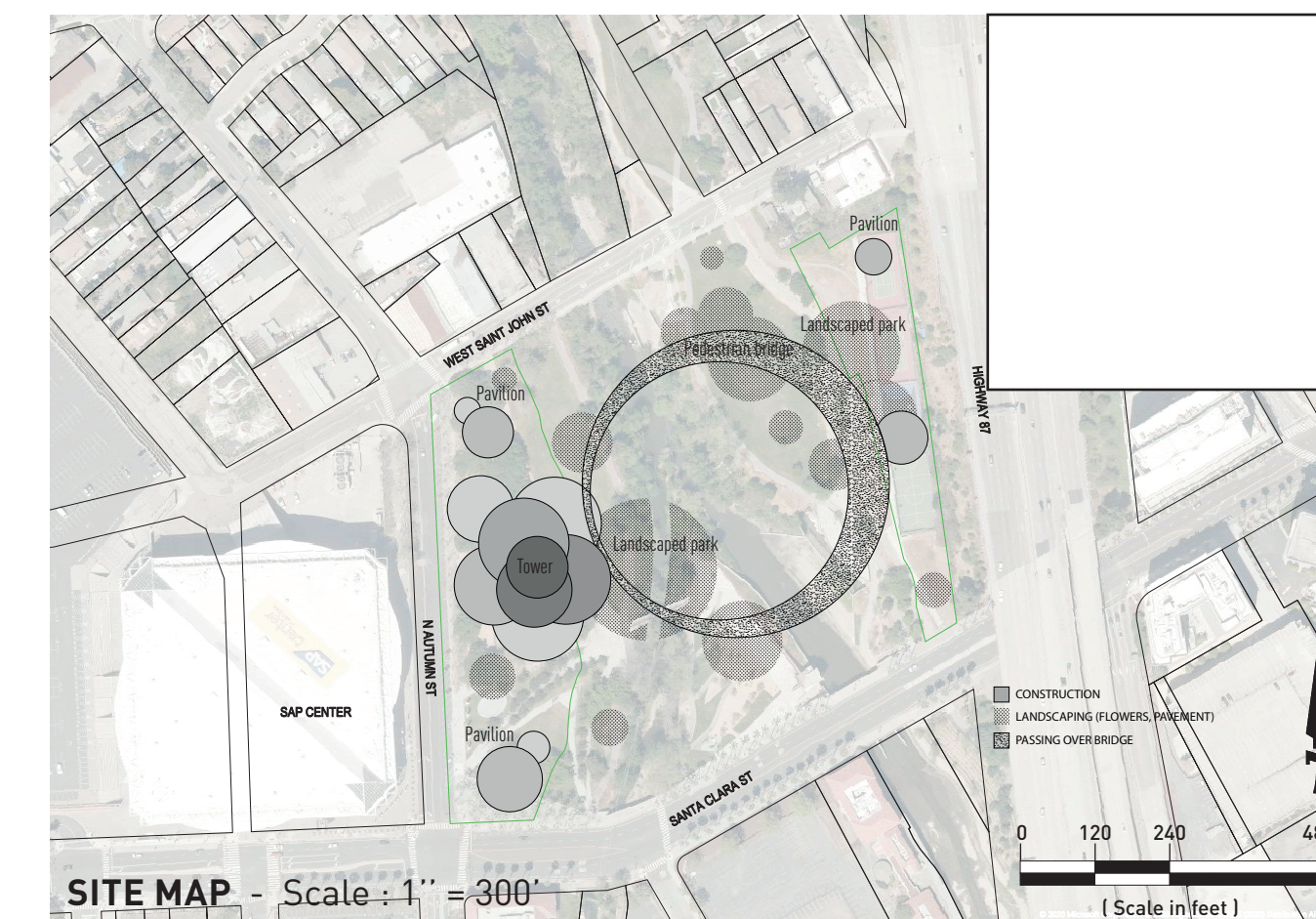

SITE PLAN - Scale : 1" = 80'

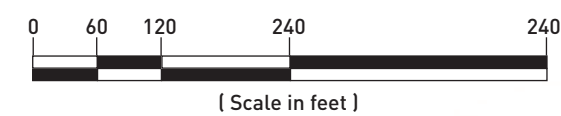

## KALEIDOSCOPE OF SAN JOSE

Probably the main characteristics of this project is its organic connection with the nature. Its identity thrives from the codes of nature, such as growth, blossom or unforced yet obvious order of elements, defining its beauty at the same time. One can find this colorful, dynamic composition refreshing and spontaneous. Perhaps even unique in the long list of landmarks, monuments and iconic forms. Its vivid presence creates the joyful feeling of happiness and evokes the sensation of harmonious interaction between the human and the nature.

Therefore, it becomes welcoming and accessible to the public. Once inside one has many choices between cultural activities, sports, leisure etc. in the ascending mode of its structure. Nature is planted everywhere, inside as well as on its platforms. Like a huge arboretum, the inner and outer spaces are changing seasonally. It is not imposing its presence as an artefact in some rigid shape, in fact it adapts and communicates with the surrounding and with various human activities.

Its façade's porosity and shiny transparency reflect the inner event around it and vice versa, thus becomes an agglomeration of spaces with merging and overlapping events. It is like a constant surprise. During the night, its skin acts like an emissive lighthouse and during the day it interacts with sunrays in kaleidoscopic manner.

The park is imagined as a whole, a one united experience; in order to avoid the separation of two sides, the project develops gentle landscape treatments in similar circular shapes as the main tower, only without the built structure, zones with colored pavement, monochromatic plants, playgrounds etc. Only the pedestrian bridge is directly connecting the main tower with the other side of the river, bringing some sort of a multifunctional 'high line' structure passing over the park and through the trees.

Future development of urban tissue will only accentuate this space as an exclusive 'empty space of the city', a main gathering space and a focal point of the future San Jose.

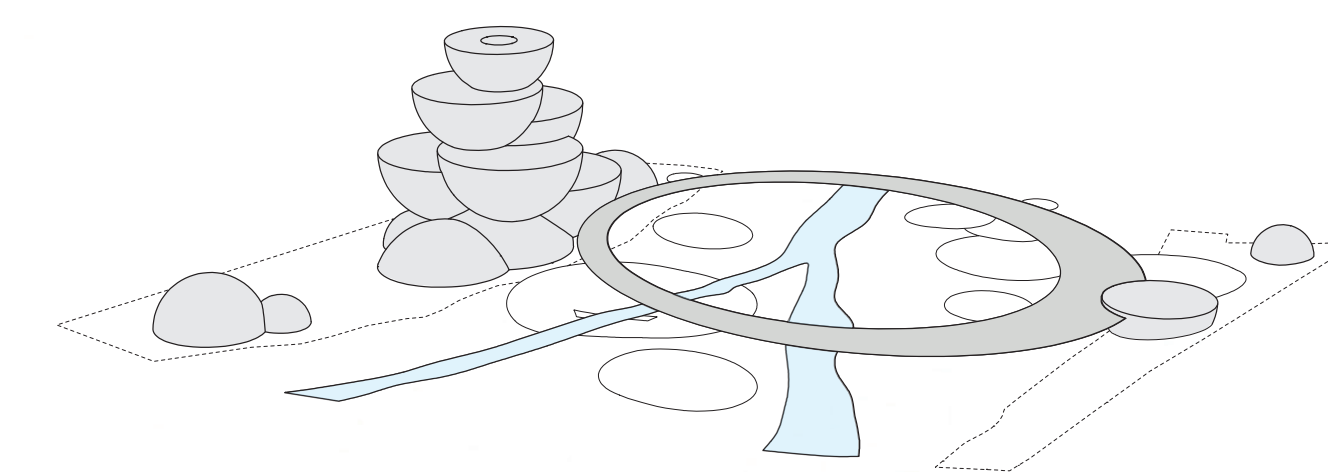

ELEVATION - Scale : 1" = 20'

