



Liebert[®] SRC[™]

Mini-Split Cooling System

Installer/User Guide

Technical Support Site

If you encounter any installation or operational issues with your product, check the pertinent section of this manual to see if the issue can be resolved by following outlined procedures. For additional assistance, visit <https://www.VertivCo.com/en-us/support/>

TABLE OF CONTENTS

1 Important Safety Instructions	7
2 Model Number Nomenclature	13
2.1 Model-number Nomenclature Detail	13
3 Product Introduction	15
3.1 Electrical Data	21
3.2 R-410A Refrigerant	22
4 Pre-installation Preparation and Guidelines	23
4.1 Selecting the Location for the Outdoor Unit	23
4.1.1 Ambient-air Conditions	24
4.1.2 Oceanside Applications	24
4.2 Clearance Requirements	26
4.2.1 Outdoor Unit Clearance	27
4.2.2 Indoor Unit Clearance	29
5 Installation	31
5.1 Mounting the Outdoor Unit	31
5.1.1 Mounting-platform Guidelines	31
5.1.2 Tie-down and Wind-restraint Guidelines	32
5.1.3 Considerations for Snow and Ice Conditions	32
5.2 Installing a Wind Baffle on the Outdoor Unit	32
5.2.1 Precautions for Wind Baffle Installation	32
5.2.2 Wind-baffle Assembly Inspection and Installation	32
5.3 Installing the Indoor Unit	34
5.3.1 Mounting the Installation Plate to the Wall (SRC18)	34
5.3.2 Mounting the Installation Plate to the Wall (SRC24 and SRC36)	36
5.3.3 Drilling a Piping Hole in the Wall	38
5.3.4 Installing the Optional Condensate Pump	39
5.3.5 Mounting the Indoor Unit to the Plate	43
5.3.6 Prepare for Piping/Electrical Connection	45
5.4 Pump Down Procedure	46
6 Installation Checklist	49
7 Piping Requirements	51
7.1 Creating a Flare Fitting	51
7.2 Tightening Flare Nuts	53
7.2.1 Loosening Flare Nuts	54
7.3 Piping Materials and Handling	54
7.3.1 Brazing Practices	56
7.3.2 Refrigerant-piping Insulation Guidelines	56
7.3.3 Selecting Field-supplied Copper Tubing	57
7.3.4 No Pipe Size Substitutions	58
7.3.5 Obstacles	58

7.3.6	Copper Expansion and Contraction	59
7.3.7	Pipe Bends	62
7.3.8	In-line Refrigeration Components	62
7.3.9	Field-provided Isolation Ball Valves	62
7.3.10	Using Elbows	62
7.3.11	Pipe Supports	62
7.3.12	Pipe Sleeves at Penetrations	64
7.3.13	Underground Refrigerant Piping	65
7.4	Piping Connections	66
7.4.1	Connection Limitations	66
7.4.2	Piping Connections Layout	66
7.4.3	Routing the Drain Hose for Indoor Unit	70
7.4.4	Installing a Drain Hose on the Outdoor Unit	72
7.4.5	Connecting Piping on the Outdoor Unit	73
7.4.6	Connecting Piping on the Indoor Unit	75
7.5	Insulating Refrigeration Piping	79
7.5.1	Minimum Requirements for Wall Thickness of Ethylene Propylene Diene Methylene (EPDM) Pipe Insulation	81
7.6	Air Purging	82
7.6.1	Piping Leak Test	84
7.6.2	Evacuation	86
7.6.3	Removing Purge and Test Equipment	87
8	Electrical Connections	89
8.1	Power-supply and Power-wiring Specifications	89
8.2	Communication-cable Specifications	92
8.3	Communication Cables between the Unit and Controller	92
8.4	Connecting Outdoor Unit Electrical Wiring	92
8.5	Thermostat Installation and Wiring	94
9	Installation Set-up and System Start-up	101
9.1	Accessing Installer Set-up Mode	101
9.2	Running Test Mode	103
9.3	Setting the Address of Central Control	103
9.4	Setting E.S.P.	104
9.5	Setting the Thermistor	104
9.6	Setting the Ceiling Height	105
9.7	Setting Fahrenheit/Celsius	106
9.8	Setting Optional Functions	106
9.9	Setting Temperature Range	106
10	Operation	109
10.1	Operating the Unit	109
10.2	Automatic Unit Restart	109
10.3	Enabling Cooling-only Mode	110
10.4	Disabling Cooling-only Mode	110

10.5 Standard Operation	111
10.5.1 Selecting Cooling Mode	111
10.5.2 Selecting Power Cooling	111
10.5.3 Selecting Heating Mode	111
10.5.4 Selecting Dehumidification Mode	112
10.5.5 Selecting Fan Mode	112
10.5.6 Selecting Auto Mode	112
10.5.7 Selecting Timed Override	113
10.5.8 Selecting Set Back	113
10.5.9 Setting the Temperature	113
10.5.10 Adjusting Air Flow	113
10.5.11 Selecting Energy-saving Cooling	114
10.5.12 Selecting Automatic Drying	114
10.5.13 Selecting Fan Auto	114
10.6 Function Settings	114
10.6.1 Setting Louver Angle Control	114
10.6.2 Locking the Display	115
10.6.3 Setting the Minimum Difference between the Cooling and Heating Setpoints	115
10.6.4 Setting Current Time	115
10.6.5 Setting Override Time	115
10.6.6 Setting Set-back Temperature	116
10.6.7 Clearing the “Clean Filter” Alarm	116
10.7 Schedule Set-up	116
10.7.1 Simple Schedule	116
10.7.2 Setting a Sleep Schedule	116
10.7.3 Setting a Weekly Schedule	117
10.7.4 Copying/Pasting a Schedule	117
10.7.5 Scheduling a Holiday	118
10.7.6 Delete all Schedules	118
11 Maintenance	119
11.1 Cleaning the Air Filter	120
11.1.1 Cleaning the Air Filter on Type 1 Units	120
11.1.2 Cleaning the Air Filter on Type 2 Units	121
11.2 Cleaning the Optional 3M or Triple Filter	122
12 Troubleshooting	125
12.1 Self-diagnosis at the Indoor Unit	125
12.2 Before Calling for Service	125
12.3 Self-diagnosis at the Thermostat	125
12.4 Troubleshooting Error Codes at the Indoor and Outdoor Units	126
12.4.1 Decoding Error Display for SRC18	126
12.5 Troubleshooting Table	128
12.6 Refrigerant Leaks	130

Appendices	133
Appendix A: Technical Support and Contacts	133

1 IMPORTANT SAFETY INSTRUCTIONS

SAVE THESE INSTRUCTIONS

This manual contains important safety instructions that should be followed during the installation and maintenance of the Liebert SRC. Read this manual thoroughly before attempting to install or operate this unit.

Only qualified personnel should move, install or service this equipment.

Adhere to all warnings, cautions, notices and installation, operating and safety instructions on the unit and in this manual. Follow all installation, operation and maintenance instructions and all applicable national and local building, electrical and plumbing codes.



WARNING! Arc flash and electric shock hazard. Open all local and remote electric power-supply disconnect switches, verify with a voltmeter that power is Off and wear personal protective equipment (PPE) per NFPA 70E before working within the electric control enclosure. Failure to comply can cause serious injury or death. Customer must provide earth ground to unit, per NEC, CEC and local codes, as applicable. Before proceeding with installation, read all instructions, verify that all the parts are included and check the nameplate to be sure the voltage matches available utility power. The Liebert controller does not isolate power from the unit, even in the “Unit Off” mode. Some internal components require and receive power even during the “Unit Off” mode of the controller. The only way to ensure that there is NO voltage inside the unit is to install and open a remote disconnect switch. Refer to unit electrical schematic. Follow all local codes.



WARNING! Risk of over-pressurization of the refrigeration system and explosive discharge of high-pressure refrigerant. Can cause loss of refrigerant, environmental pollution, equipment damage, injury or death. This unit contains fluids and gases under high pressure. Use extreme caution when charging the refrigerant system. Do not pressurize the system higher than the design pressure marked on the unit's nameplate.





WARNING! Risk of improper installation. Can cause equipment and building damage, injury or death. Utilize a structural engineer to evaluate the mounting surface and environmental risks and recommend the safest fastening method.





WARNING! Risk of protective safety devices not operating properly. Can cause electrical short circuit, electric shock, explosion, fire, injury or death. Do not change the settings of the protection devices and only use replacement parts that are specified by Vertiv™.

 **WARNING!** Risk of electric shock. Can cause equipment damage, injury or death. Open all local and remote electric power supply disconnect switches and verify with a voltmeter that power is off before working within any electric connection enclosures. Service and maintenance work must be performed only by properly trained and qualified personnel and in accordance with applicable regulations and manufacturers' specifications. Opening or removing the covers to any equipment may expose personnel to lethal voltages within the unit even when it is apparently not operating and the input wiring is disconnected from the electrical source.

 **WARNING!** Risk of contact with high-speed moving parts. Can cause injury or death. Open all local and remote electric power-supply disconnect switches, verify with a voltmeter that power is off, and verify that all the fan blades have stopped moving before working in the unit.

 **WARNING!** Risk of unit mounting base deterioration and collapse. Can cause building and equipment damage, injury or death. Periodically verify the equipment mounts have not deteriorated.

 **CAUTION:** Risk of contact with sharp edges, splinters, and exposed fasteners. Can cause injury. Only properly trained and qualified personnel wearing appropriate, OSHA-approved PPE should attempt to move, lift, remove packaging from or prepare the unit for installation.

 **CAUTION:** Risk of contact with extremely hot and/or cold surfaces. Can cause injury. Verify that all components have reached a temperature that is safe for human contact or wear appropriate, OSHA-approved PPE before working within the electric connection enclosures or unit cabinet. Perform maintenance only when the system is de-energized and component temperatures have become safe for human contact.

 **CAUTION:** Risk of improper lifting and moving of a heavy unit. Can cause building and equipment damage and injury. Be very careful when transporting the product. Do not attempt to carry the product without assistance. Some products use polypropylene bands for packaging. Do not use polypropylene bands to lift the unit. Suspend the unit from the base at specified positions. Support the unit a minimum of four points to avoid slippage from rigging apparatus. Verify that all lifting apparatus is rated for the weight of the unit.

NOTICE

Risk of release of hazardous substances into the environment. Can cause environmental pollution and violation of environmental regulations.

The Liebert SRC contains substances and components hazardous for the environment (electronic components, refrigerating gases and oils). At the end of its useful life, the Liebert SRC must be dismantled by specialized refrigerating technicians. The unit must be delivered to suitable centers specializing in the collection and disposal of equipment containing hazardous substances.

NOTICE

Risk of exposure to corrosive environments. Can cause equipment damage. Don't install the unit where it's directly exposed to ocean winds.

Ocean winds may cause corrosion, particularly on the condenser and evaporator fins, which, in turn could cause product malfunction or inefficient performance.

NOTICE

Risk of water damage and abnormal vibration. Can cause equipment damage

When installing the unit in a low-lying area, or a location that is not level, use a raised concrete pad or concrete blocks to provide a solid, level foundation.

NOTICE

Risk of excessive condensation. Can cause building and equipment damage.

Properly insulate all cold surfaces to prevent "sweating." Cold surfaces such as uninsulated piping can generate condensate that may drip and cause a slippery floor condition and/or water damage to walls.

NOTICE

Risk of exposure to excessive Electro-Magnetic Interference. Can cause equipment malfunction.

When installing the unit in a hospital, mechanical room, or similar electromagnetic field (EMF) sensitive environment, provide sufficient protection against electrical noise.

Inverter equipment, power generators, high-frequency medical equipment, or radio communication equipment may cause the unit to operate improperly. The unit may also affect such equipment by creating electrical noise that disturbs medical treatment or image broadcasting.

NOTICE

Risk of using the wrong refrigerant. Can cause equipment damage

Do not make refrigerant substitutions. Use R-410A only.

If a different refrigerant is used, or air mixes with original refrigerant, the unit will malfunction and be damaged.

NOTICE

Risk of excessive vibration and water leakage. Can cause building and equipment damage

Keep the unit upright during installation to avoid compressor, piping and component damage.

NOTICE

Risk of improper refrigerant piping practices. Can cause refrigerant leaks resulting in building and equipment damage

When connecting refrigerant tubing, remember to allow for pipe expansion. Improper piping may cause refrigerant leaks and system malfunction.

NOTICE

Risk of an improper installation location. Can cause equipment damage

Install the unit in a safe location where nobody can step on or fall onto it. Do not install the unit on a defective stand. Periodically check that the outdoor frame is not damaged

NOTICE

Risk of leaking water. Can cause building and equipment damage.

Install the drain hose as specified in this manual to ensure adequate drainage and periodically check for damage, obstruction and leaks.

NOTICE

Risk of leaking refrigerant. Can cause equipment malfunction and damage.

Always check for system refrigerant leaks after the unit has been installed or serviced. Low refrigerant levels may cause product failure.

NOTICE

Risk of cold compressor at startup. Can cause equipment damage.

Provide power to the compressor crankcase heaters at least six (6) hours before operation begins.

Starting operation with a cold compressor sump(s) may result in severe bearing damage to the compressor(s). Keep the power switch on during the operational season.

NOTICE

Risk of blocked inlet and outlet air vents. Can cause equipment malfunction and damage. Do not block the inlet or outlet. Unit may malfunction.

NOTE: Do not install the unit in a noise sensitive area.

NOTE: Take appropriate actions at the end of HVAC equipment life to recover, recycle, reclaim or destroy R-410A refrigerant according to applicable U.S. Environmental Protection Agency (EPA) rules.

NOTE: Don't store or use flammable gas / combustibles near the unit. There is risk of product failure.

NOTE: Clean up the site after installation is finished, and check that no metal scraps, screws, or bits of wiring have been left inside or surrounding the unit.

NOTE: Do not use this equipment in mission critical or special purpose applications such as preserving foods, works of art, wine coolers or refrigeration. The equipment is designed to provide cooling and heating for electronic and telecommunications equipment. Oil, steam, sulfuric smoke, etc., can significantly reduce the performance of the unit, or damage its parts.

NOTE: If the leaking battery fluid has been swallowed, wash off the inside of the mouth thoroughly and consult a doctor.

NOTE: Do not drink the water drained from the unit.

NOTE: Do not use the product for special purposes, such as preserving foods, works of art, and etc. It is an unit for consumer purposes, not a precision refrigeration system. There is risk of damage or loss of property.







NOTE: Do not recharge or disassemble the batteries.

NOTE: Maintenance:

- Never touch the metal parts of the unit when removing the air filter.
- Use a sturdy stool or ladder when cleaning, maintaining, or repairing the unit at a height.
- Never use strong cleaning agents or solvents when cleaning the unit or spray water.
- Use a smooth cloth.

Table 1.1 below, describes symbols may appear within the documentation or on the product.

Table 1.1 Safety Symbols

SYMBOL	MEANING
	High temperature—Alerts the user where the enclosure temperature may exceed 158°F (70°C) while operating under high-ambient temperature and at maximally rated load.
	Instructions—Signifies the presence of important operating and maintenance (servicing) instructions in the literature accompanying the appliance.
	Dangerous voltage—Warns about the presence of uninsulated dangerous voltage within the product’s enclosure that may be of sufficient magnitude to constitute a risk of electric shock to persons.
	Power on—Indicates the principal On/Off switch is in the On position.
	Power off—Indicates the principal On/Off switch is in the Off position.
	Protective grounding terminal—Indicates a terminal that must be connected to earth ground before any other connections to the equipment may be made.

This page intentionally left blank.

2 MODEL NUMBER NOMENCLATURE

This section describes the model-number configuration for Liebert SRC units and components.

2.1 Model-number Nomenclature Detail

Table 2.2 below describes each digit of the model number.

Table 2.1 Liebert SRC Model Number Example

1	2	3	4	5	6	7	8	9	10	11
S	R	C	2	4	H	P	N	0	0	0

Table 2.2 SRC Model-number Digit Definitions

DIGIT	DESCRIPTION
Digits 1 - 3	Unit Family SRC = Liebert SRC
Digits 4 - 5	Nominal Capacity Btu/h 18 = 18,000 24 = 24,000 36 = 36,000
Digit 6	AHRI Type H = Heat pump
Digit 7	Voltage P = 208 - 230/1/60
Digit 8	Unit Type N = Indoor evaporator C = Outdoor condensing unit
Digit 9	Placeholder
Digit 10	Placeholder
Digit 11	Revision number

This page intentionally left blank.

3 PRODUCT INTRODUCTION

Suggestions for Energy Saving when Operating the Liebert SRC:

- Do not cool excessively indoors. This may be harmful for your health and may consume more electricity.
- Block sunlight with blinds or curtains while you are operating the unit.
- Keep doors or windows closed tightly while you are operating the unit.
- Adjust the direction of the air flow vertically or horizontally to circulate indoor air.
- Speed up the fan to cool or warm indoor air quickly, within a short period of time.
- Open windows regularly for ventilation. The indoor air quality may deteriorate if the unit is used for long durations.
- Clean the air filter once every 2 weeks. Dust and impurities collected in the air filter may block the air flow or weaken the cooling / dehumidifying functions.

Figure 3.1 Indoor Unit Parts and Functions

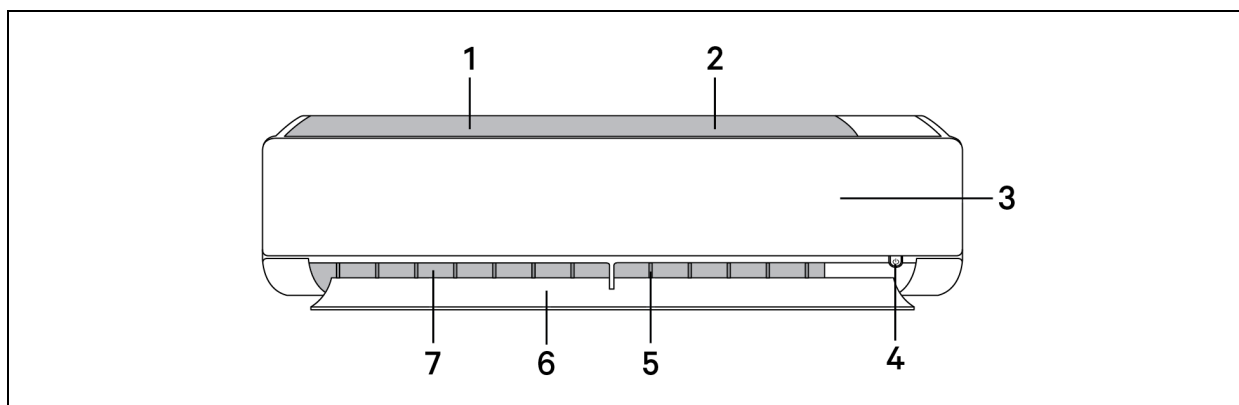

ITEM	DESCRIPTION	ITEM	DESCRIPTION
1	Air filter (under the panel)	5	Air deflector (vertical louver)
2	Air intake	6	Air deflector (horizontal vane)
3	Front cover	7	Air outlet
4	On/Off button		

NOTE: The number and location of operation lamps may vary by unit model. The features may vary by model.

Figure 3.2 Outdoor Unit Parts and Functions

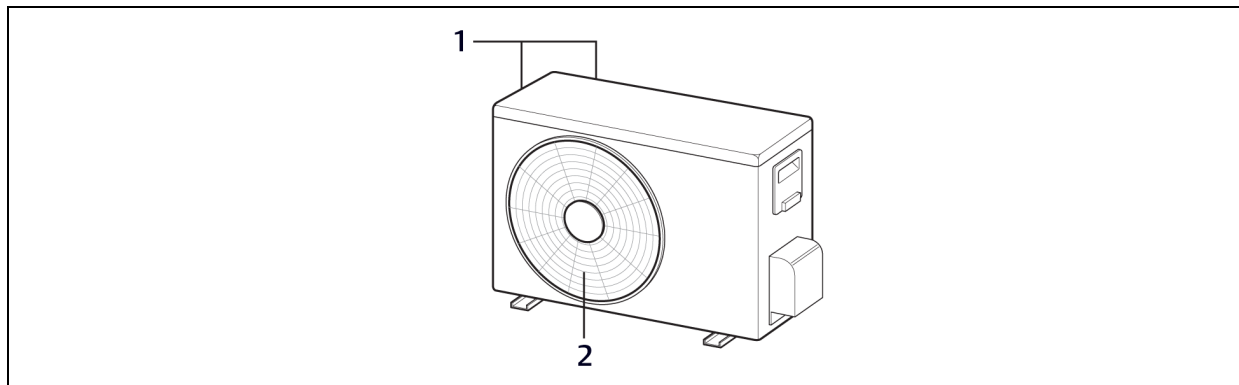

ITEM	DESCRIPTION
1	Air intake vents
2	Air outlet vents

NOTE: Some functions may not be available or displayed depending on unit type.

Figure 3.3 Thermostat parts and functions

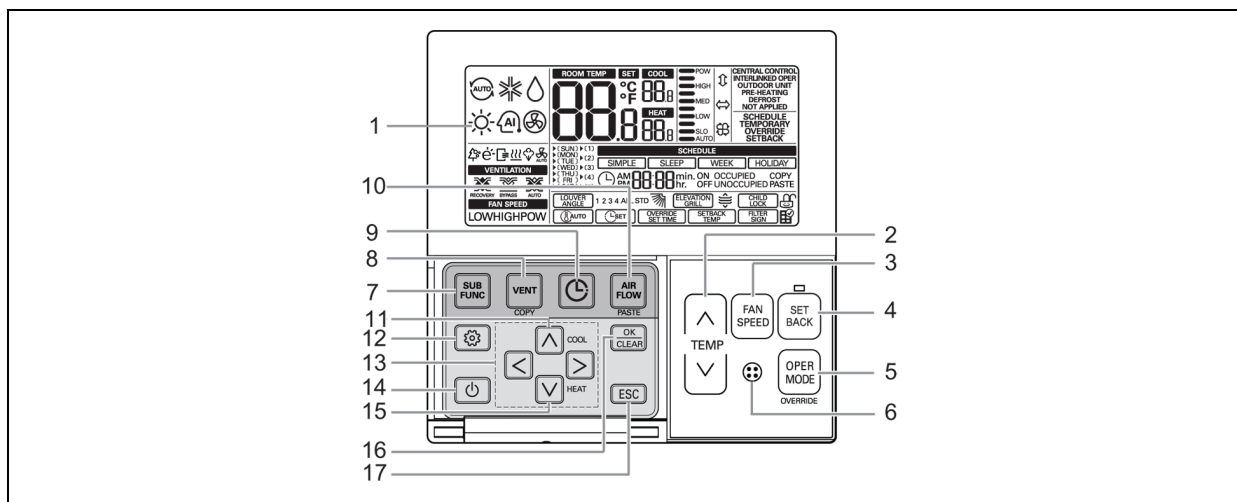

ITEM	DESCRIPTION	ITEM	DESCRIPTION
1	Operation indication	10	Air-flow button
2	Set temperature button	11	Cooling temperature setpoint
3	Fan speed button	12	Function setting button
4	Set back button	13	Up, down, left and right buttons
5	Operation-mode select button	14	On/Off button
6	Wireless thermostat receiver (not included on some models)	15	Heating temperature setpoint
7	Sub function button	16	Set/Cancel button
8	Ventilation button	17	Exit button
9	Reservation button		

Figure 3.4 Accessories

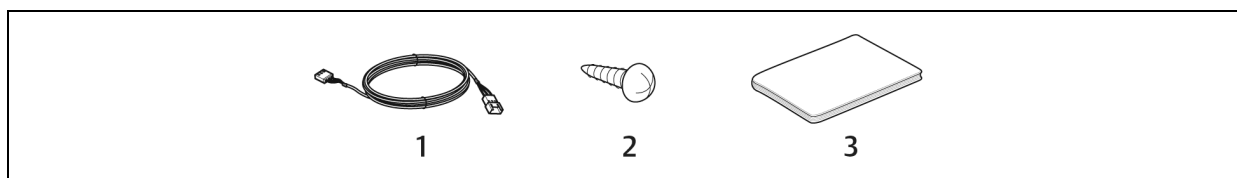

ITEM	DESCRIPTION	ITEM	DESCRIPTION
1	Connection cable, 1 each, 32 ft (10 m)	3	User Manual
2	Screw, 4 each		

NOTE: Some options and functions may not be displayed or the menu name may be different depending on your system and model.

Figure 3.5 Icon descriptions and functions

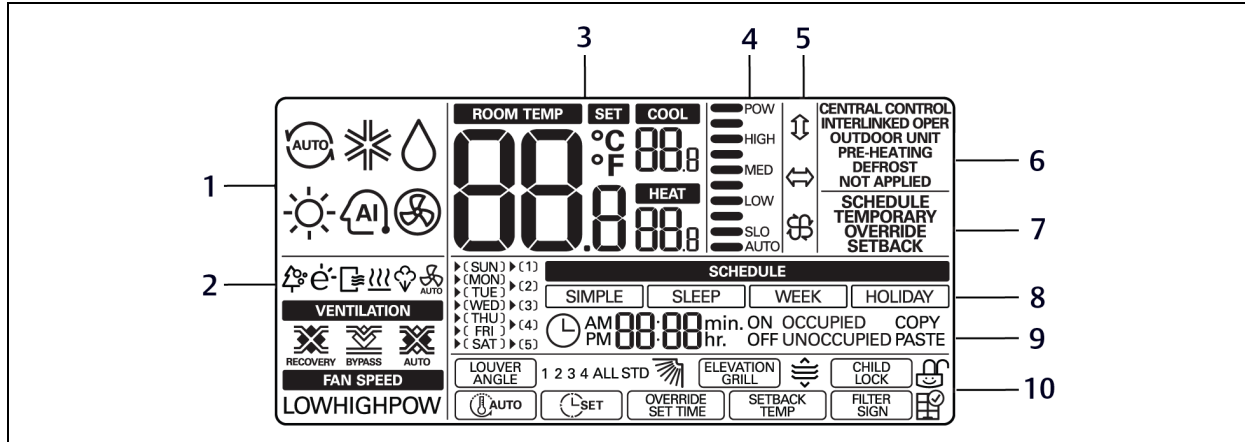

Table 3.1 Icon Descriptions

ITEM	SECTION	ICON	DESCRIPTION
1	Operating Mode		Auto—change to cooling or heating mode automatically.
			Operating in cooling mode.
			Operating in dehumidification mode.
			Operating in heating mode.
			Operating in fan-only mode.

Table 3.1 Icon Descriptions (continued)

ITEM	SECTION	ICON	DESCRIPTION
2	Sub functions		Plasma purification filter is operating.
			Energy-saving cooling mode, operating in limited temperature range.
			Automatic drying is operating.
			Electric heater is operating in heater mode.
			Humidifier is operating.
		 AUTO	Automatic fan function on indoor unit. The fan doesn't operate in the indoor unit when the compressor is off.
3	Temperature		Current temperature.
			Cooling temperature setpoint.
			Heating temperature setpoint.
4	Fan Speed	 POW HIGH MED LOW SLO AUTO	Fan-speed settings.
5	Air-flow/Louvers		Swing louvers up/down.
			Swing louvers left/right.
			Swing louvers for "swirl" (paired, opened cross swing).
6	Controller Modes		Operate in schedule mode.
			Temporarily operate in a mode.
			Override schedule (occupied/unoccupied).
			Operate in set-back mode.

Table 3.1 Icon Descriptions (continued)

ITEM	SECTION	ICON	DESCRIPTION
7	State Monitoring	CENTRAL CONTROL	Command received from central controller or outdoor unit.
		INTERLINKED OPE	Slave indoor unit to a heat-pump system. Prevents changing to a mode that is incompatible with the current mode of the outdoor unit.
		OUTDOOR UNIT	Outdoor unit is operating.
		PRE-HEATING	Indoor unit is pre-heating.
		DEFROST	Defrost is operating.
		NOT APPLIED	Function is not applied.
8	Schedule	SIMPLE	Simple schedule is in use.
		SLEEP	Sleep schedule is in use.
		WEEK	Weekly schedule is in use.
		HOLIDAY	Holiday schedule is in use.
		SUN MON TUE WED THU FRI SAT	Day of Week: SUN = Sunday MON = Monday TUE = Tuesday WED = Wednesday THU = Thursday FRI = Friday SAT = Saturday
9	Schedule Set-up	1 2 3 4 5	Number of the weekly-schedule event.
		AM PM	Schedule time AM/PM.
		0000	Schedule time hour/minute.
		min. hr.	min. = minute. hr. = hour.
		OCCUPIED UNOCCUPIED	Weekly schedule occupied/un-occupied state.
		COPY PASTE	Copy/Paste schedule data.

Table 3.1 Icon Descriptions (continued)

ITEM	SECTION	ICON	DESCRIPTION
10	Function Settings		Louver set-up.
		1 2 3 4 ALL STD	1, 2, 3, 4, All = louver number. STD = standard louver angle setting.
			Angle of the louver.
			Elevation grill set-up.
			Grill up.
			Grill closed.
			Grill down.
			Display lock set-up
			Display is locked.
			Display is not locked.
			Set-up minimum-difference value between cooling and heating setpoints.
			Set current time.
			Set timer for schedule override.
			Set-up default setback for cooling/heating temperature setpoints.
	Clear the air-filter cleaning alarm.		
	Check the indoor-unit air filter and clean if necessary.		

3.1 Electrical Data

Table 3.2 Unit Electrical Data

MODEL	NOM. TONS	COMPRESSOR QTY.	COMPRESSOR (A) COOL/HEAT	FAN QTY.	ODU FAN (A)	IDU FAN (A)	MCA (A)	MOP (A)
SRC18	1-1/2	1	14.6/14.6	1	0.25	0.40	19	25
SRC24	1-3/4	1	17.3/17.3	1	0.25	0.5	23	35
SRC36	2-3/4	1	17.3/17.3	1	0.25	0.5	23	35

3.2 R-410A Refrigerant

R-410A refrigerant has a higher operating pressure in comparison to R22 refrigerant and, therefore, all piping-system materials installed must have a higher resisting pressure than the materials traditionally used in R22 systems.

R-410A refrigerant is an azeotrope of R32 and R125, mixed at 50:50, so the ozone depletion potential (ODP) is zero. Many countries have approved-of and encouraged R-410A for use as an alternate refrigerant.



WARNING! Risk of piping ruptures and refrigerant leaks. Can cause equipment damage, illness, serious injury and death from suffocation. Do not use piping that is not approved for use in high-pressure refrigerant systems. Refrigerant leaks in non-ventilated spaces could cause oxygen depletion levels that are dangerous to discharging and charging.

NOTE: Piping wall thickness must comply with the applicable local, state, and federal codes for the 551-psi design pressure of R-410A. Because R-410A is a combination of R32 and R125, the required additional refrigerant must be charged in its liquid state. If the refrigerant is charged in its gaseous state, its composition changes and the system will not work properly.

4 PRE-INSTALLATION PREPARATION AND GUIDELINES

NOTE: Before installing unit, determine whether any building alterations are required to run piping, wiring and duct work.

4.1 Selecting the Location for the Outdoor Unit



WARNING! Risk of improper installation. Can cause serious injury or death. To avoid the possibility of fire, do not install the unit in an area where combustible gas may generate, flow, stagnate, or leak. Do not install the unit in a location where acidic solution and spray (sulfur) are often used. Do not use the unit in environments where oil, steam, or sulfuric gas are present.

NOTICE

Risk of unauthorized access to the unit. Can cause equipment malfunction or damage.

Install a fence to prevent vermin from crawling into the unit or unauthorized individuals from accessing it.

Select a location for installing the outdoor unit that will meet the following conditions:

- Where the unit will not be subjected to direct thermal radiation from other heat sources.
- Where operating sound from the unit will not disturb inhabitants of surrounding buildings.
- Where the unit will not be exposed to direct, strong winds.
- Where there is enough strength to bear the weight of the unit.
- Include space for drainage to ensure condensate flows properly out of the unit when it is in heating mode.
- Include enough space for air flow and for service access.

To ensure that the outdoor unit operates properly, certain measures are required in locations where there is a possibility of heavy snowfall or severe wind chill or cold.

1. Prepare for severe winter wind chills and heavy snowfall, even in areas of the country where these are unusual phenomena.
2. Position the outdoor unit so that its airflow fans are not buried by direct, heavy snowfall. If snow piles up and blocks the airflow, the system may malfunction.
3. Remove any snow that has accumulated 3-15/16 inches or more on the top of the outdoor unit.
4. Place the outdoor unit on a raised platform at least 19-11/16 inches higher than the average annual snowfall for the area. In environments where there is a possibility of heavy snow, the frame height must be more than 2 times the amount of average annual snowfall, and should not exceed the width of the outdoor unit. If the frame width is wider than the outdoor unit, snow may accumulate.
5. Install a snow-protection hood.

6. To prevent snow and heavy rain from entering the outdoor unit, install the suction and discharge ducts facing away from direct winds.
7. Additionally, the following conditions should be taken into consideration when the unit operates in defrost mode:
 - If the outdoor unit is installed in a highly-humid environment (near an ocean, lake, etc.), ensure that the site is well-ventilated and has a lot of natural light. (For example: Install on a rooftop.)
 - Sidewalks or parking lots near the outdoor unit may accumulate moisture after unit operates in defrost mode that can turn into ice.

Installation location of the outdoor unit can affect indoor-unit operation. The indoor unit may take longer to provide heat, or heating performance will be reduced in winter in the outdoor unit is installed:

- In a narrow, shady location.
- Near a location that has a lot of ground moisture.
- In a highly-humid environment.
- In an area in which condensate does not drain properly.

4.1.1 Ambient-air Conditions

NOTICE

Risk of exposure to improper environmental conditions. Can cause equipment damage.

- Avoid exposing the outdoor unit to steam, combustible gases, or other corrosive elements.
- Avoid exposing the unit to discharge from boiler stacks, chimneys, steam relief ports, other air-conditioning units, kitchen vents, plumbing vents, or substances that may degrade performance or cause damage to the unit.
- When installing multiple outdoor units, avoid placing the units where discharge of one outdoor unit will blow into the inlet side of an adjacent unit.

4.1.2 Oceanside Applications

Using a Windbreak to Shield the Unit from Sea Wind

NOTE: Ocean winds may cause corrosion, particularly on the condenser and evaporator fins, which, in turn could cause product malfunction or inefficient performance.

- Avoid installing the unit where it would be directly exposed to ocean winds.
- Install the outdoor unit on the side of the building opposite from direct ocean winds.
- Select a location with good drainage.
- Periodically clean dust or salt particles off of the heat exchanger with water.
- If the outdoor unit must be placed in a location where it would be subjected to direct ocean winds, install a concrete windbreak strong enough to block any winds, see Figure 4.1 on the facing page for windbreak location.
- The windbreak should be more than 150% of the outdoor unit's height. There must be 2 to 3-1/2 inches of clearance between the outdoor unit and the windbreak for purposes of flow.

Figure 4.1 Oceanside placement using a windbreak

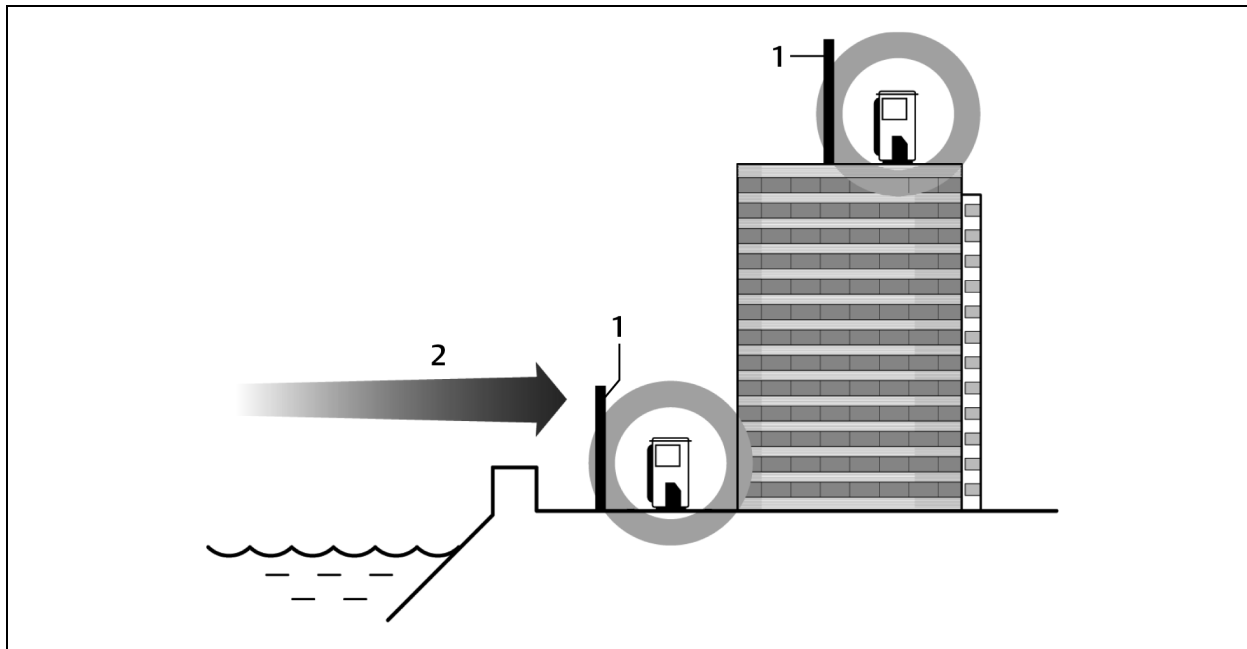

ITEM	DESCRIPTION
1	Windbreak
2	Sea wind

Using a Building to Shield the Unit from Sea Wind

If a windbreak is not possible, a building or larger structure must be used to shield the outdoor unit from direct exposure to the sea wind. The unit should be placed on the side of the building directly opposite to the direction of the wind as shown in Figure 4.2 below.

Figure 4.2 Oceanside placement using a building

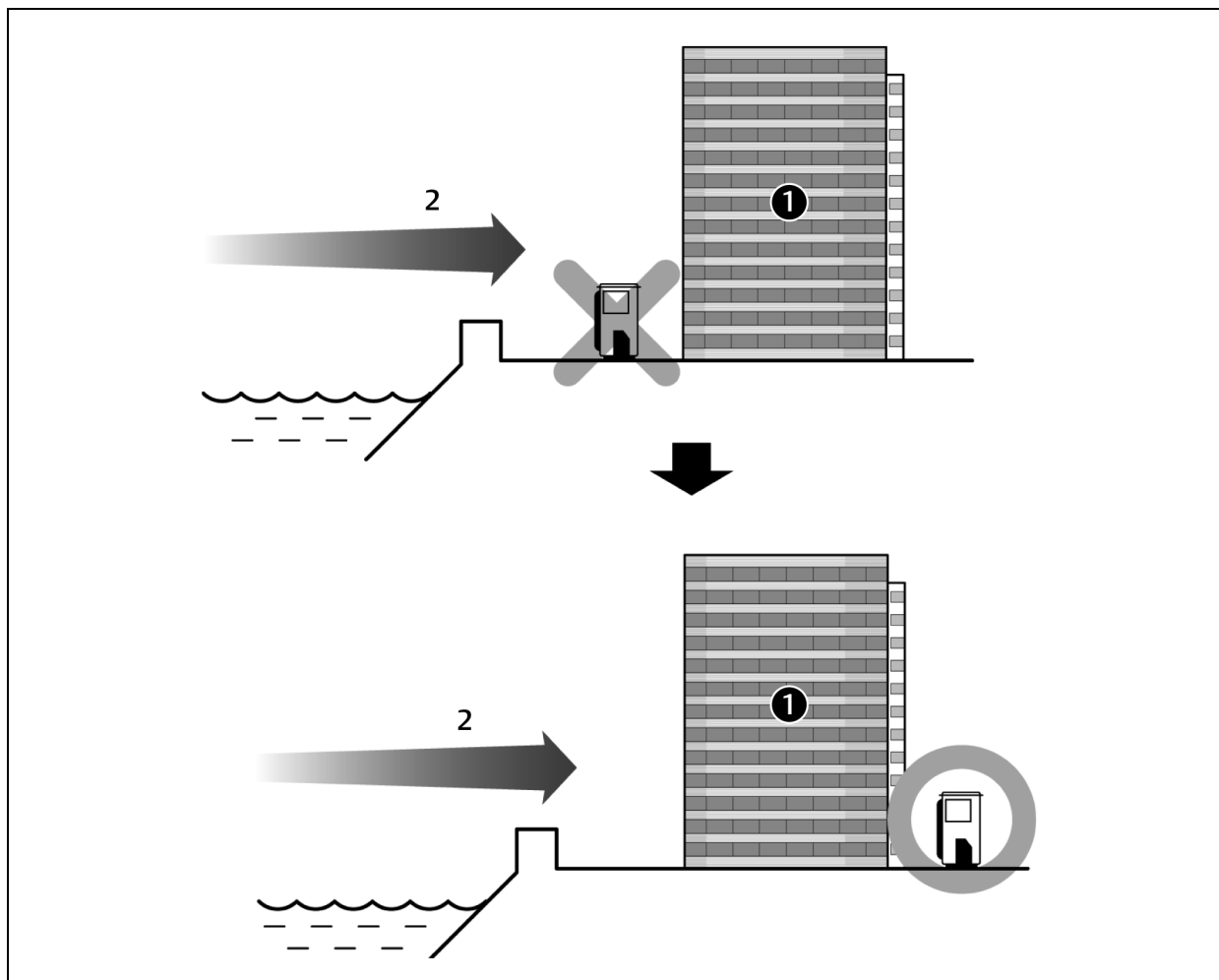

ITEM	DESCRIPTION
1	Building
2	Sea wind

4.2 Clearance Requirements

Proper airflow through the outdoor unit coil is critical for correct unit operation. When installing, consider service, inlet and outlet, and minimum allowable space requirements as illustrated in Figure 4.3 on the facing page.

4.2.1 Outdoor Unit Clearance

Specific clearance requirements are for the wall-mount systems. Figure 4.3 below shows the overall minimum clearances that must be observed for safe operation and adequate airflow around the outdoor unit.

Figure 4.3 Outdoor-unit clearances

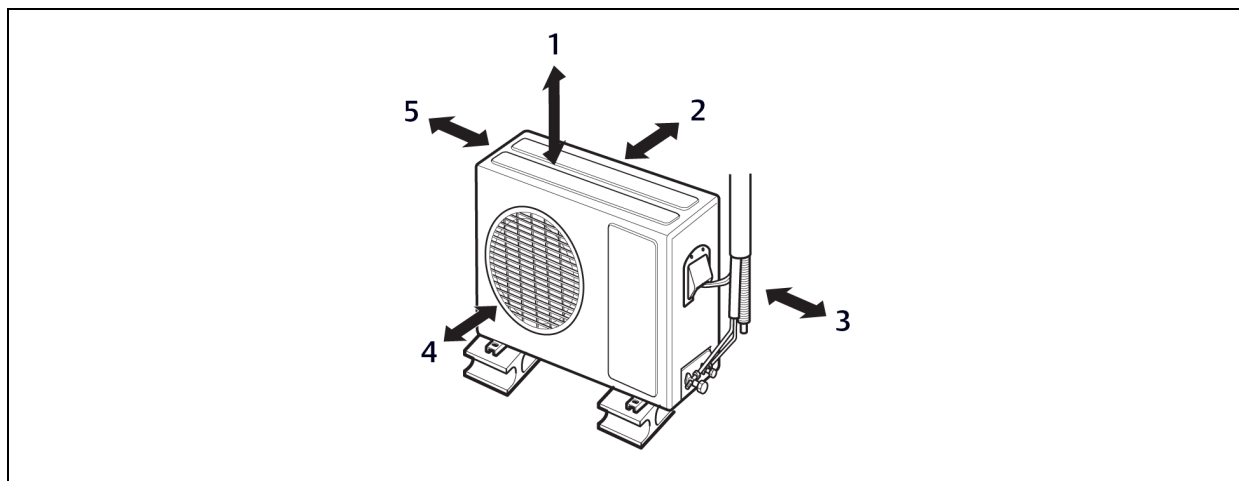

ITEM	DESCRIPTION	ITEM	DESCRIPTION
1	More than 24 inches.	4	More than 28 inches.
2	More than 12 inches.	5	More than 12 inches.
3	More than 24 inches.		

When placing the outdoor unit under an overhang, awning, sunroof or other “roof-like” structure, observe the clearance requirements (as shown in Figure 4.4 on the next page) for height in relation to the unit. This clearance ensures that heat radiation from the condenser is not restricted around the unit. See Figure 4.5 on the next page and Figure 4.6 on page 29 for recommendations when other obstacles are present.

Adhere to all clearance requirements if installing the unit on a roof. Be sure to level the unit and ensure that the unit is adequately anchored. Consult local codes for roof-top mounting requirements.

NOTE: Do not place the unit where animals and/or plants will be in the path of the warm air, or where the warm air and/or noise will disturb neighbors.

Figure 4.4 Outdoor-unit sunroof/awning clearances

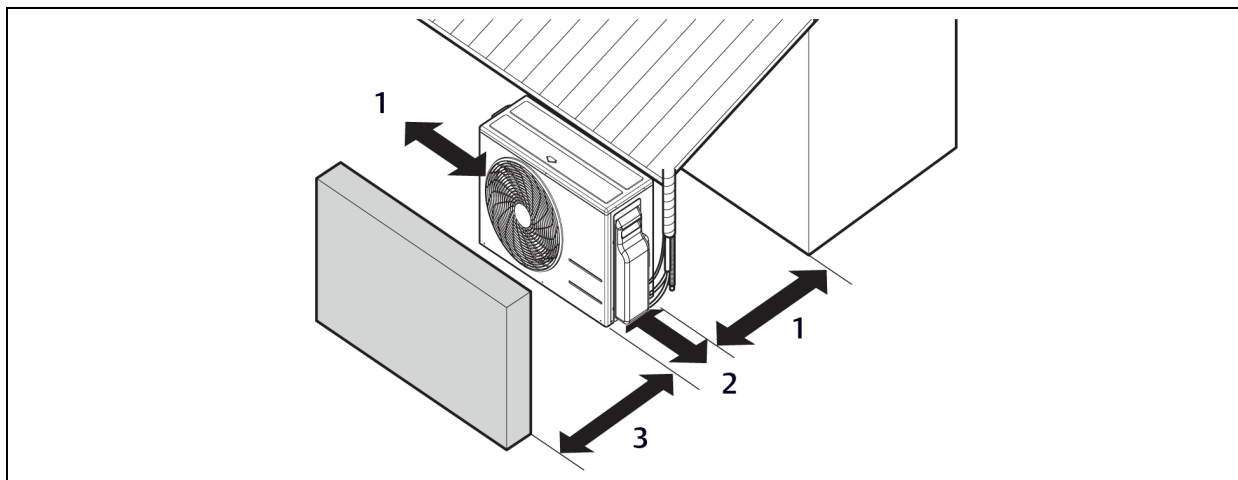

ITEM	DESCRIPTION
1	More than 12 inches.
2	More than 24 inches.
3	More than 28 inches.

Figure 4.5 Clearances when there are obstacles on both air-inlet and air-outlet sides

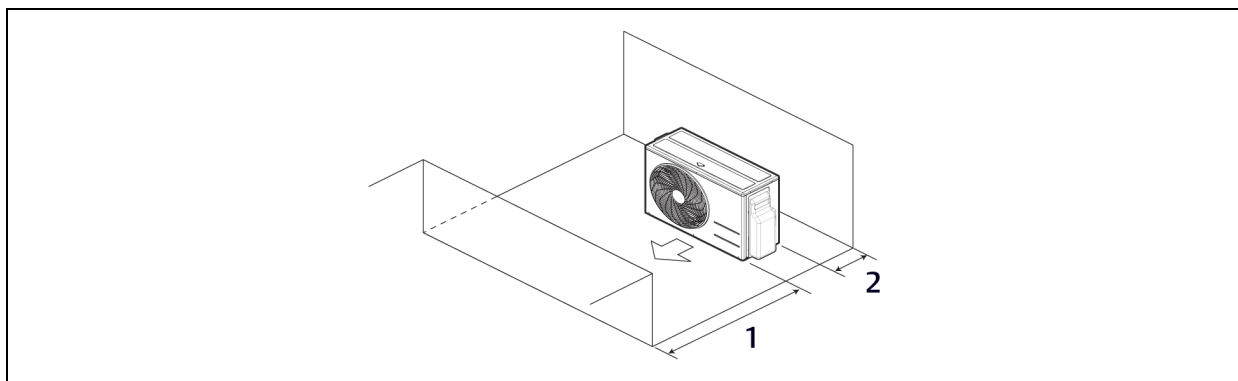

ITEM	DESCRIPTION
1	More than 28 inches.
2	More than 12 inches.

NOTE: In Figure 4.5 above and Figure 4.6 on the facing page, the obstacle on the outlet side is lower than the outdoor unit.

Figure 4.6 Clearances when there are obstacles above and on both air-inlet and air-outlet sides

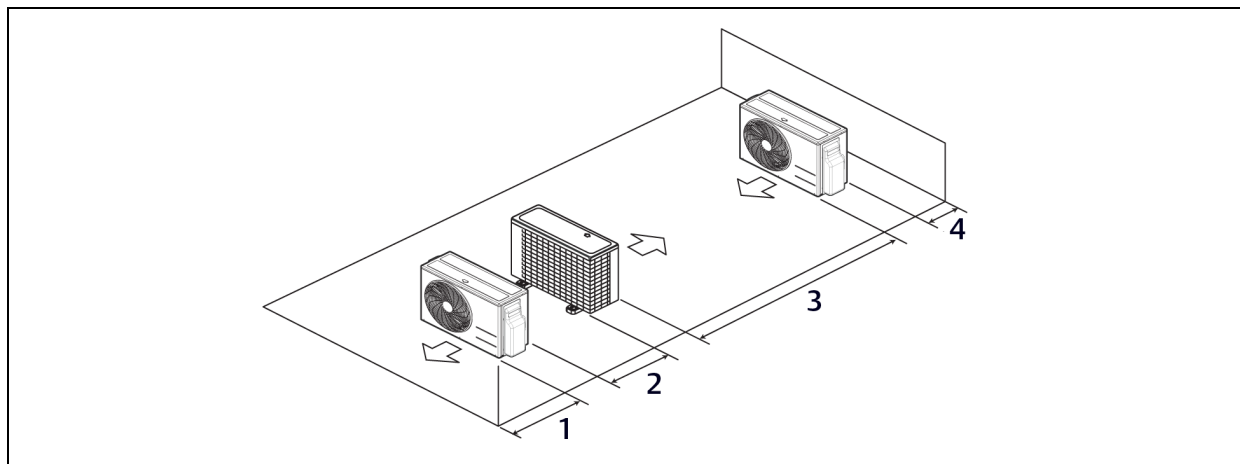

ITEM	DESCRIPTION	ITEM	DESCRIPTION
1	More than 28 inches.	3	79 inches
2	24 inches	4	More than 12 inches.

4.2.2 Indoor Unit Clearance

Follow recommended practices when choosing an indoor location for the wall-mounted indoor unit.

- Keep unit away from any indoor steam or excessive heat.
- No obstacles should be placed around the unit.
- Condensation drain (leakage piping) should be routed away from the unit.
- Do not install near a doorway.
- Clearance gap between any wall or enclosure and the left or right side of the unit must be greater than 4 inches, Figure 4.7 on the next page.
- From the top of the unit to the ceiling, there must be greater 8 inches of clearance, see Figure 4.7 on the next page.
- Unit should be at least 6.5 feet from the floor for adequate clearance.

Figure 4.7 Indoor unit clearance requirements

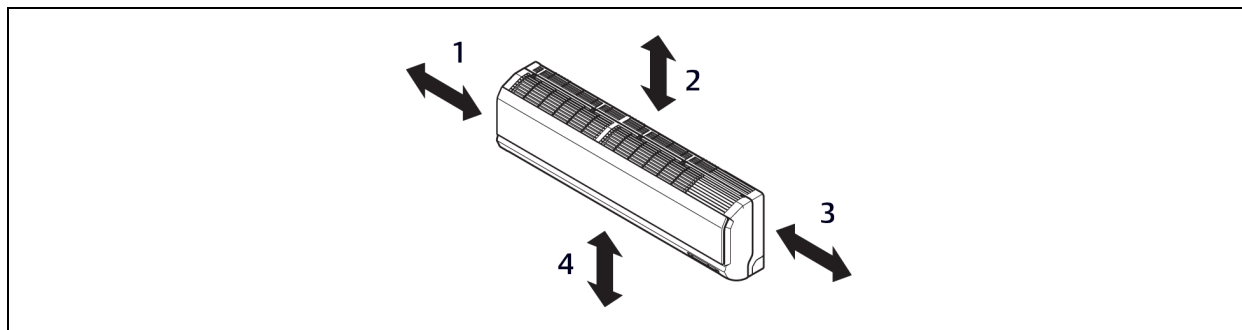

ITEM	DESCRIPTION	ITEM	DESCRIPTION
1	More than 4 inches.	3	More than 4 inches.
2	Minimum clearance from ceiling - 6 in.	4	At least 6.5 feet from floor.

5 INSTALLATION

5.1 Mounting the Outdoor Unit

Securely attach the outdoor unit to a condenser pad, base rails, or another mounting platform that is securely anchored to the ground or building structure. Attach the outdoor unit with a bolt and nut on a concrete or rigid mount. See Figure 5.1 below. Follow applicable local codes for clearance, mounting, anchor and vibrations attenuation requirements.

NOTE: All referenced materials are field-supplied. Images are not to scale.

Figure 5.1 Outdoor unit mounting methods

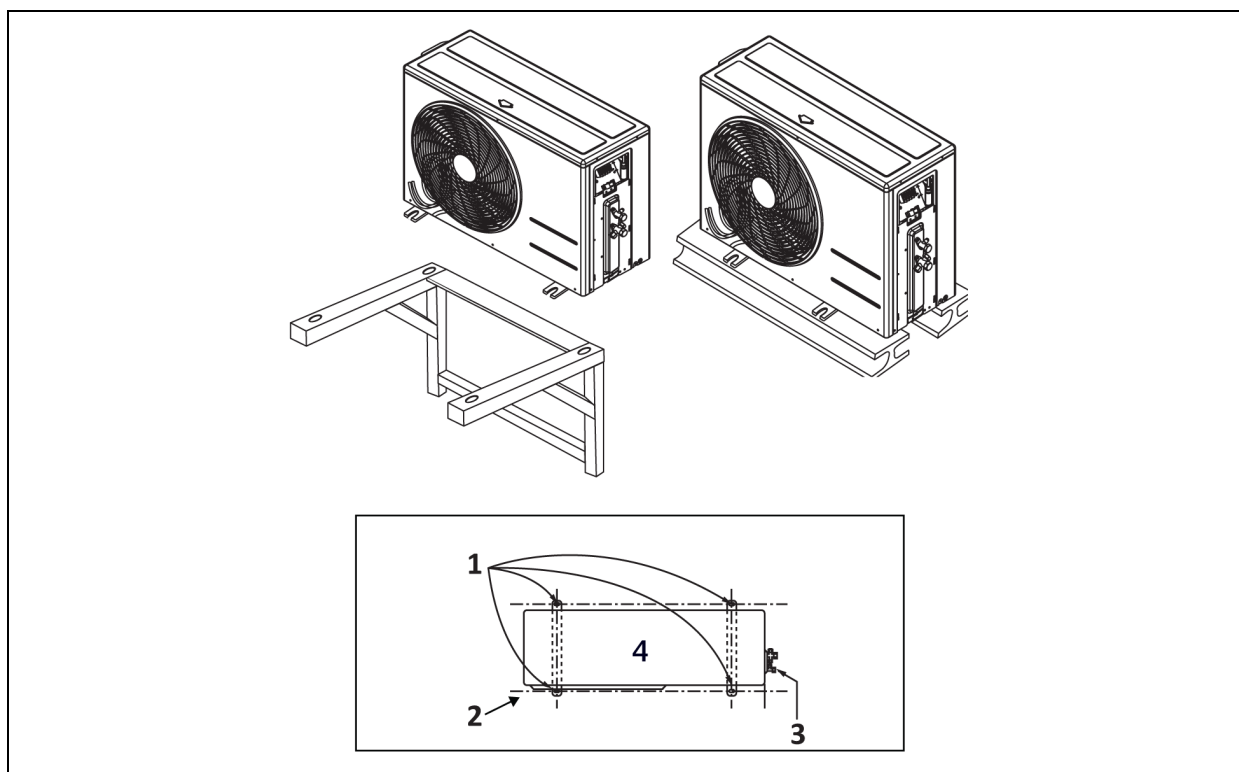

ITEM	DESCRIPTION	ITEM	DESCRIPTION
1	Bolt placement and Anti-vibration pad	3	Piping connection
2	Foundation	4	Top of unit

5.1.1 Mounting-platform Guidelines

The underlying structure or foundation must be designed to support the weight of the unit. Avoid placing the unit in a low-lying area where water may accumulate. When installing the outdoor unit on the wall or roof top, anchor the mounting base securely to account for wind, earthquake or vibration.

5.1.2 Tie-down and Wind-restraint Guidelines

The strength of the inverter system frame is adequate to be used with field-provided wind restraint tie-downs. The overall tie-down configuration must be approved by a local, professional engineer.

NOTE: Always refer to local code when designing a wind-restraint system.

5.1.3 Considerations for Snow and Ice Conditions

In climates that experience snow build-up, place the unit on a raised platform to ensure condenser air flow. The raised support platform must be high enough to allow the unit to remain above possible snow drifts. Mount the unit on a field-provided snow stand at a minimum height that is equal to the average annual snowfall plus 20 inches. Design the mount base to prevent snow accumulation on the platform in front or back of the unit case. If necessary, provide a field fabricated hood to keep snow and ice and/or drifting snow from accumulating on the coil surfaces. Use inlet and discharge duct or hoods to prevent snow or rain from accumulating on the fan inlet and outlet guards. Best practice prevents snow from accumulating on top of the unit. Consider the tie-down requirements in case of high winds or where required by local codes.



CAUTION: Risk of run-off water freezing on sidewalks and driveways. Can cause falls and injuries. When selecting the location for the outdoor unit, be sure to choose an area where run-off from defrost will not accumulate and freeze on sidewalks or driveways.

5.2 Installing a Wind Baffle on the Outdoor Unit

A wind baffle allows cooling-mode operation at lower ambient outdoor temperatures.

Read all instructions before installing wind baffles.



CAUTION: Risk of contact with sharp edges and exposed fasteners. Can cause injury. Wear appropriate, OSHA-approved personal protective equipment (PPE) when installing the component.

5.2.1 Precautions for Wind Baffle Installation

Consider the following when installing the wind baffle:

- Be sure not to damage the painted surface.
- Carefully drill holes so that no damage occurs to external or internal parts of the unit.
- Make sure that drill chips do not enter the unit.

5.2.2 Wind-baffle Assembly Inspection and Installation

1. Inspect all items for visible or concealed damage. Immediately report any damage to the carrier and file a damage claim, sending a copy of the claim to your local sales representative.
2. Remove items from packaging and refer to Table 5.1 on the facing page to verify that the assembly number is correct by SRC model to which it will be installed and that all parts are present.

Table 5.1 Wind-baffle assembly numbers, kit parts, and dimension

WIND-BAFFLE PART NUMBER	COMPATIBLE OUTDOOR UNIT	SELF-TAPPING SCREW TYPE	SELF-TAPPING SCREW QUANTITY	BAFFLE DIMENSIONS (W X H X D), IN. (MM)
327135P1	SRC18	#8 x 1/2 in.	6	19-11/16 x 19-11/16 x 7-15/16 (500 x 500 x 202)
327135P2	SRC24 SRC36		8	23-5/8 x 23-5/8 x 7-15/16 (600 x 600 x 202)

- Referring to Figure 5.2 below, center the baffle both vertically and horizontally over the fan cover. Make sure that the baffle does not cover the access panel.

Figure 5.2 Wind-baffle installation

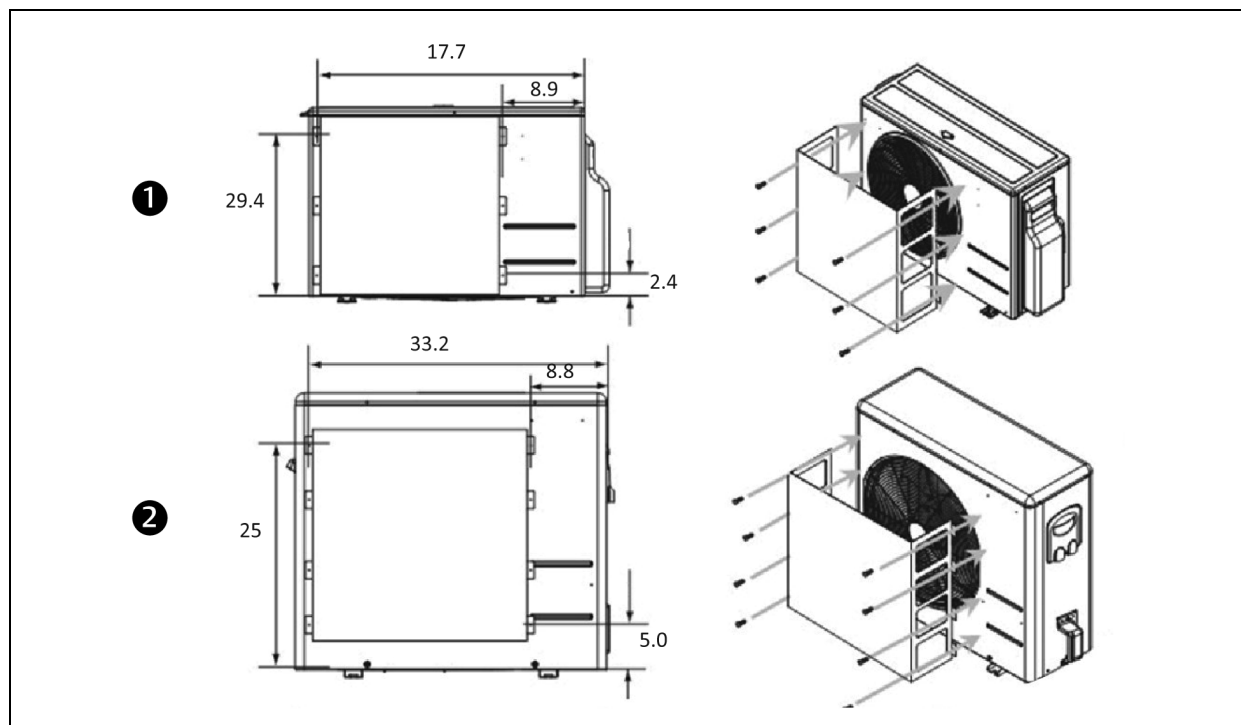

ITEM	DESCRIPTION	ITEM	DESCRIPTION
1	327135P1 (for SRC18)	2	327135P2 (for SRC24, SRC36)

- Using the drill, mark the screw-hole positions.
- Using the provided screws, connect the baffle flanges to the unit at the marked holes. Do not over-tighten the screws.
- Once the baffle is secure, check to see if the unit and baffle are working properly.

5.3 Installing the Indoor Unit

5.3.1 Mounting the Installation Plate to the Wall (SRC18)



WARNING! Risk of electric shock. Can cause equipment damage, injury or death. Open all local and remote electric power supply disconnect switches and verify with a voltmeter that power is off before working within any electric connection enclosures. Service and maintenance work must be performed only by properly trained and qualified personnel and in accordance with applicable regulations and manufacturers' specifications. Opening or removing the covers to any equipment may expose personnel to lethal voltages within the unit even when it is apparently not operating and the input wiring is disconnected from the electrical source.



WARNING! Risk of improper installation. Can cause equipment and building damage, injury or death. Utilize a structural engineer to evaluate the mounting surface and environmental risks and recommend the safest fastening method.

Observe the following guidelines when installing the mounting plate:

- When choosing a location for the wall-mount plate, be sure to take into consideration routing of wiring for power outlets within the wall.
- Use caution when drilling holes through the walls for the purposes of piping connections.
- Refer to [Drilling a Piping Hole in the Wall](#) on page 38, as you follow the plate-installation procedure.
- Unit must be anchored tightly to a wall that has sufficient strength to support the unit during operation to prevent the unit from falling or creating excessive, unnecessary vibration during operation.
- Use best practices when mounting the indoor unit's plate to a wall.

To install the indoor unit:

1. Before installation of the plate, confirm the position of the screw types (A or B) between the chassis and the installation plate, Figure 5.3 on the facing page.

Figure 5.3 Installation-plate screws for SRC18

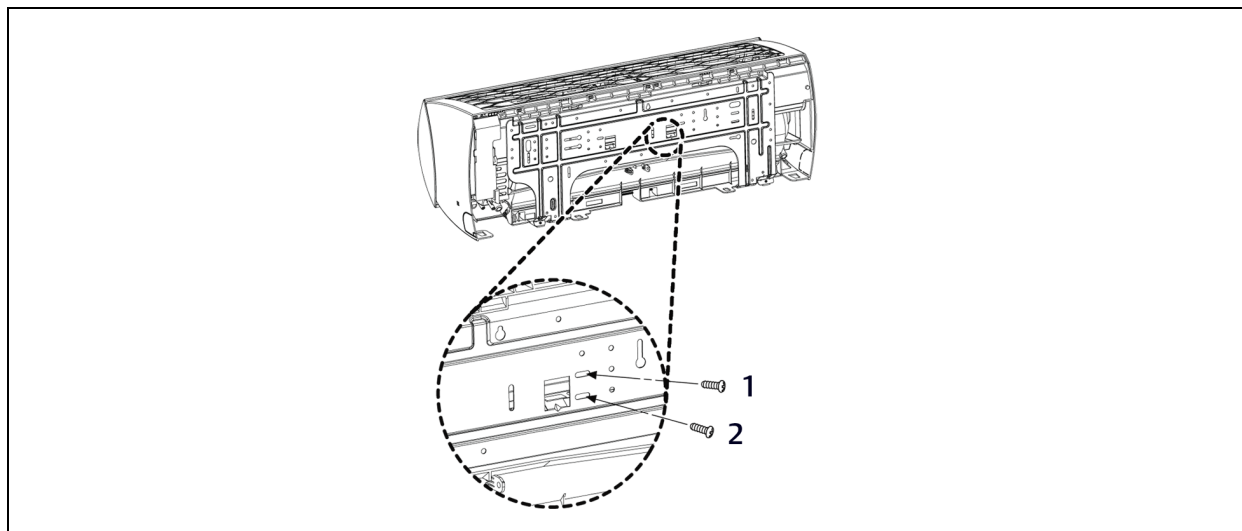

ITEM	DESCRIPTION
1	A-Type
2	B-Type

2. Depending on indoor-unit model refer to Figure 5.4 below and mount the plate as follows:
 - Use the provided screws and mount the installation plate horizontally by aligning the centerline using a leveling tool.
 - Observe the left and right rear piping clearance when drilling into the wall.

Figure 5.4 Piping clearance for SRC18 plate

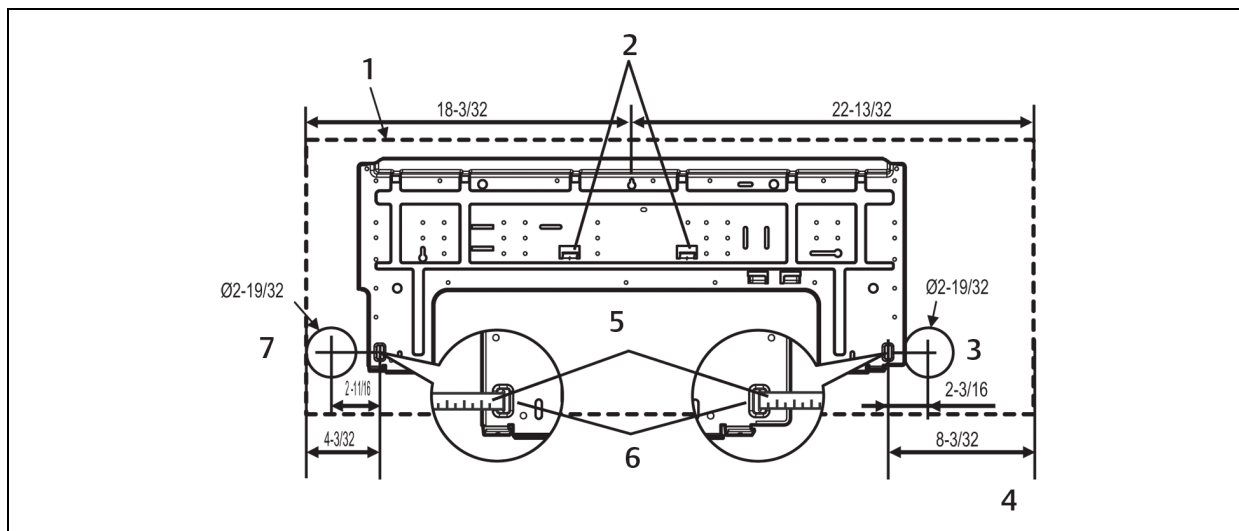

ITEM	DESCRIPTION	ITEM	DESCRIPTION
1	Unit outline.	5	Installation-plate measuring tape.
2	Place a level on raised tabs.	6	Measuring tape hanger.
3	Right rear piping.	7	Left rear piping.
4	Units = Inches		

5.3.2 Mounting the Installation Plate to the Wall (SRC24 and SRC36)

! WARNING! Risk of electric shock. Can cause equipment damage, injury or death. Open all local and remote electric power supply disconnect switches and verify with a voltmeter that power is off before working within any electric connection enclosures. Service and maintenance work must be performed only by properly trained and qualified personnel and in accordance with applicable regulations and manufacturers' specifications. Opening or removing the covers to any equipment may expose personnel to lethal voltages within the unit even when it is apparently not operating and the input wiring is disconnected from the electrical source.

! WARNING! Risk of improper installation. Can cause equipment and building damage, injury or death. Utilize a structural engineer to evaluate the mounting surface and environmental risks and recommend the safest fastening method.

Observe the following guidelines when installing the mounting plate:

- When choosing a location for the wall-mount plate, be sure to take into consideration routing of wiring for power outlets within the wall.
- Use caution when drilling holes through the walls for the purposes of piping connections.
- Refer to Figure 5.5 below, as you follow the plate-installation procedure.
- Unit must be anchored tightly to a wall that has sufficient strength to support the unit during operation to prevent the unit from falling or creating excessive, unnecessary vibration during operation.
- Use best practices when mounting the indoor unit’s plate to a wall.

To install the indoor unit:

1. Use the provided screws, mount the installation plate horizontally by aligning the centerline using a leveling tool, Figure 5.5 below.

Figure 5.5 Installation-plate screws for SRC24 and SRC36

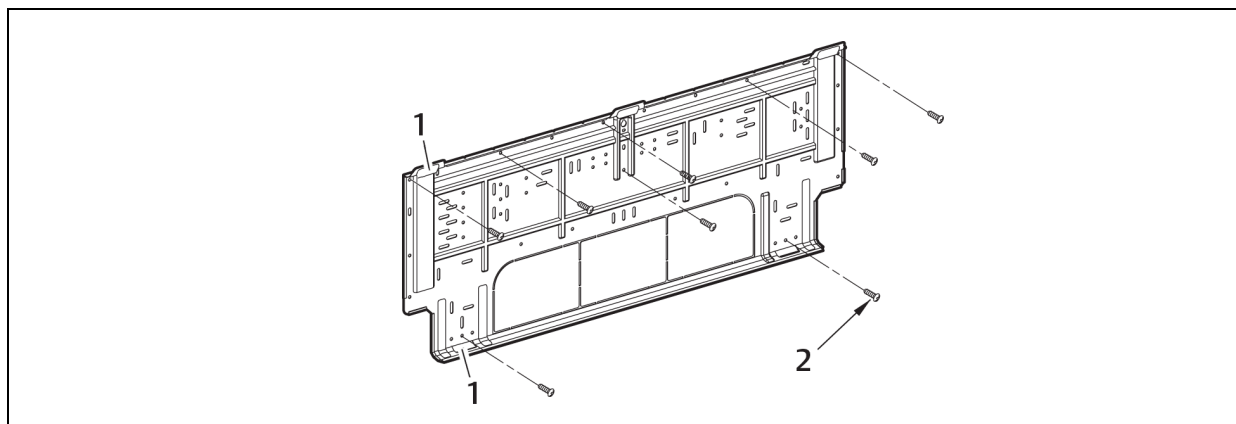

ITEM	DESCRIPTION
1	Chassis hook.
2	Type "A" screws.

2. Observe the left and right rear piping clearance when drilling into the wall, Figure 5.6 on the next page.

Figure 5.6 Piping clearance for SRC24 and SRC36

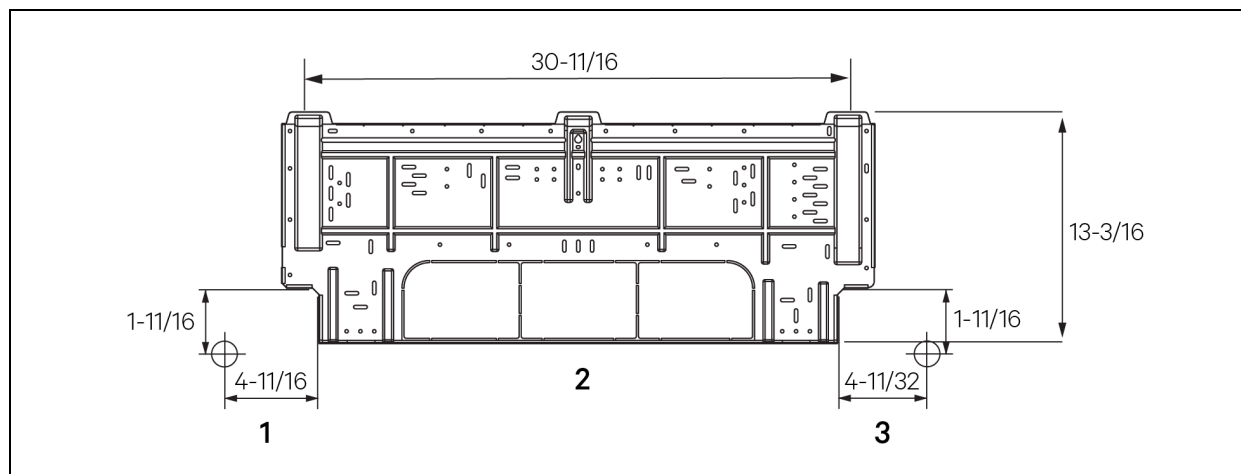

ITEM	DESCRIPTION
1	Left rear piping.
2	Unit = inches.
3	Right rear piping.

5.3.3 Drilling a Piping Hole in the Wall

Follow the left or right piping-clearance recommendations.

1. Using a 2-5/8 in. (0.65 mm) hole-core drill bits, drill a hole at either the right or left side of the wall mounting, Figure 5.7 on the facing page.
 - The slant of the hole should be 3/16 to 5/16 of an inch from level with an upward slant on the indoor-unit side and downward on the outdoor-unit side.
2. Finish-off the newly-drilled hole as shown in Figure 5.7 on the facing page with a bushing and sleeve covering.
 - The sleeve and bushing prevents damage to the tubing/bundling of the piping.

Figure 5.7 Drilling a piping hole

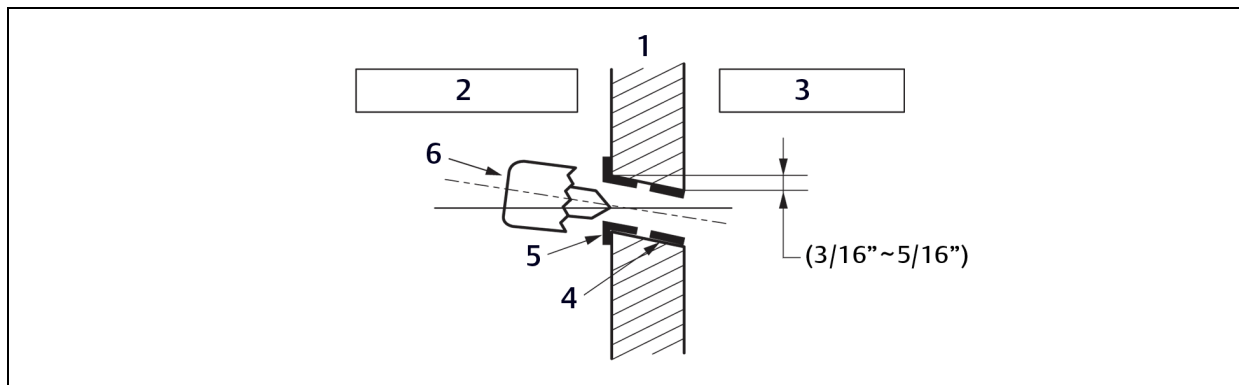

ITEM	DESCRIPTION	ITEM	DESCRIPTION
1	Wall	4	Sleeve
2	Indoor	5	Bushing
3	Outdoor	6	Core Drill

5.3.4 Installing the Optional Condensate Pump

The optional, field-installed condensate pump may be located inside or outside the evaporator section of the SRC, below the bottom of the drain pan.

The pump consist of 2 parts, the reservoir and the control unit/pump.

Figure 5.8 Condensate-pump reservoir

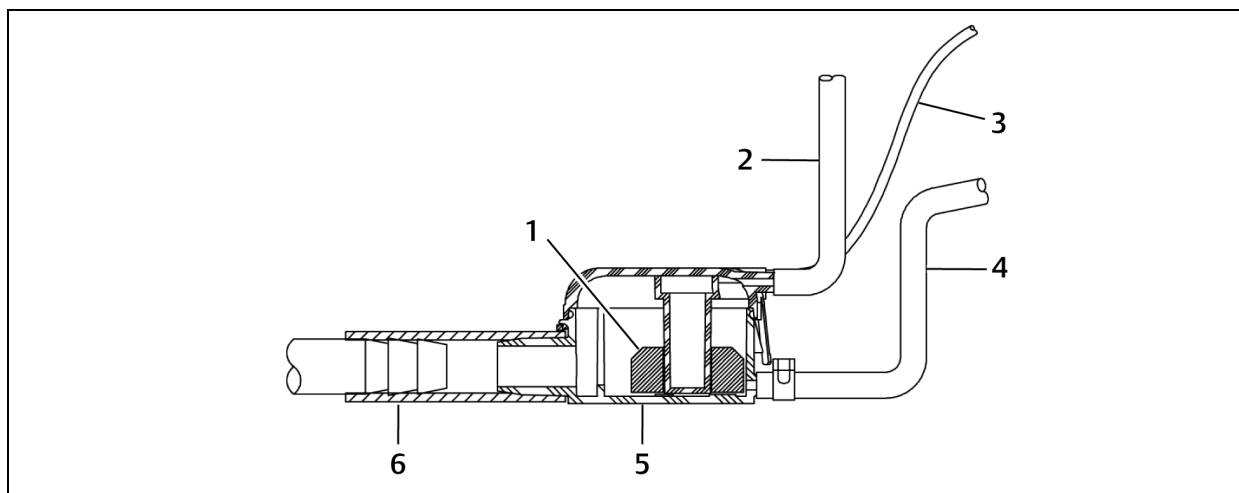

ITEM	DESCRIPTION	ITEM	DESCRIPTION
1	Float	4	Intake tube
2	Vent tube	5	Water-collecting reservoir
3	Reservoir cable	6	Water drain

Figure 5.9 Condensate-pump control unit/pump

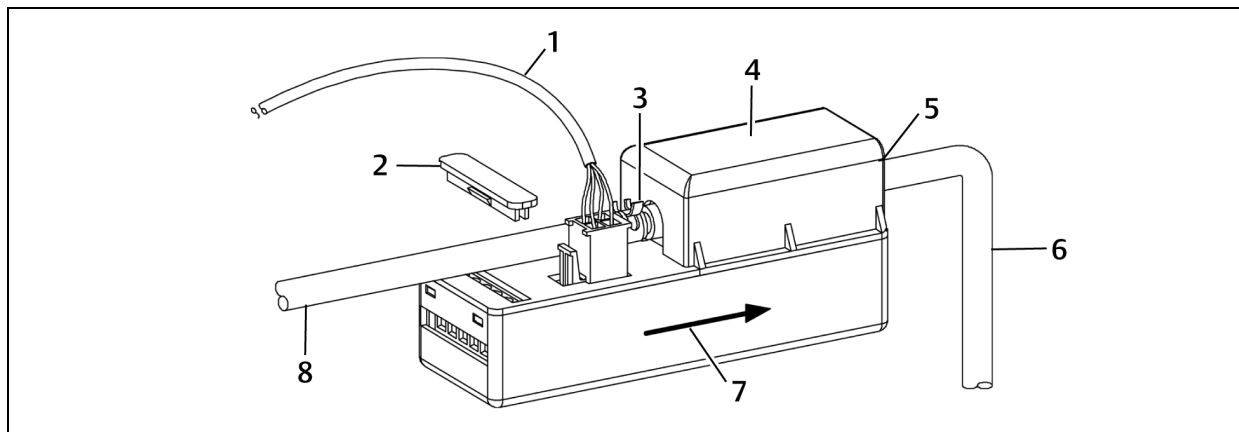

ITEM	DESCRIPTION	ITEM	DESCRIPTION
1	Reservoir cable	5	Hose clamp on end of discharge tube
2	Screw cover	6	Discharge tube
3	Hose clamp	7	Direction of flow
4	Pump	8	Intake tube

To install the pump:

1. Verify that the drain pan is free of debris.
2. Referring to Figure 5.10 below and supporting the reservoir, attach the discharge tube from the drain pan to the reservoir and be sure that the tubing does not kink.

NOTE: For clarity, the refrigerant piping lines are removed from Figure 5.10 below.

Figure 5.10 Condensate pump connection to drain pan

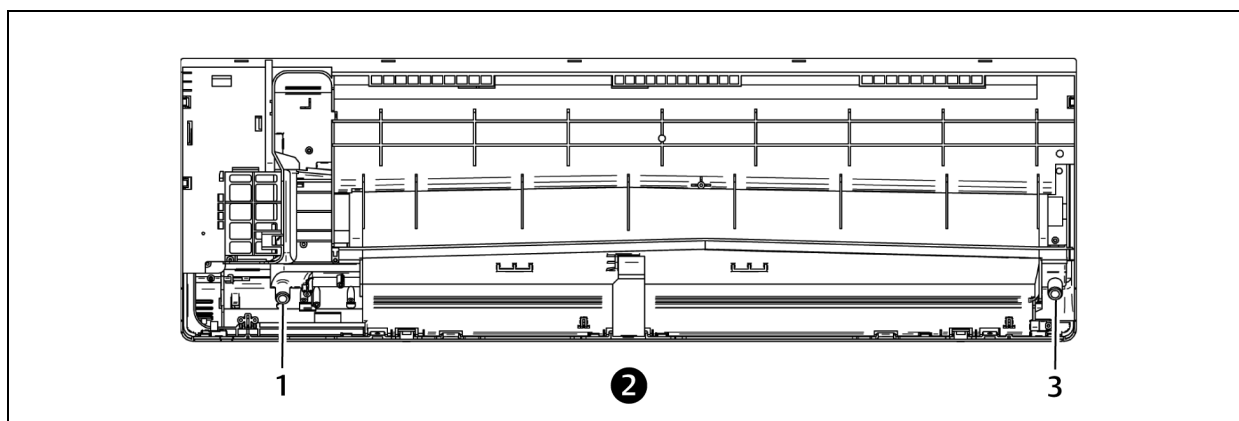

ITEM	DESCRIPTION	ITEM	DESCRIPTION
1	Vinyl discharge tube connection to reservoir inlet.	2	Rear of unit
3	Drain-pan connection		

3. Connect the breather tube to the reservoir outlet marked “VENT,” and be sure that the tubing does not kink.
4. Place the reservoir in the rear of the evaporator unit as shown in Figure 5.11 below.
 - The reservoir must be level within ± 15 degrees. Performance is optimum when the reservoir is level.

NOTE: If the reservoir is mounted improperly, the float mechanism may malfunction and may cause the unit to overflow.

Figure 5.11 Condensate pump location below drain pan

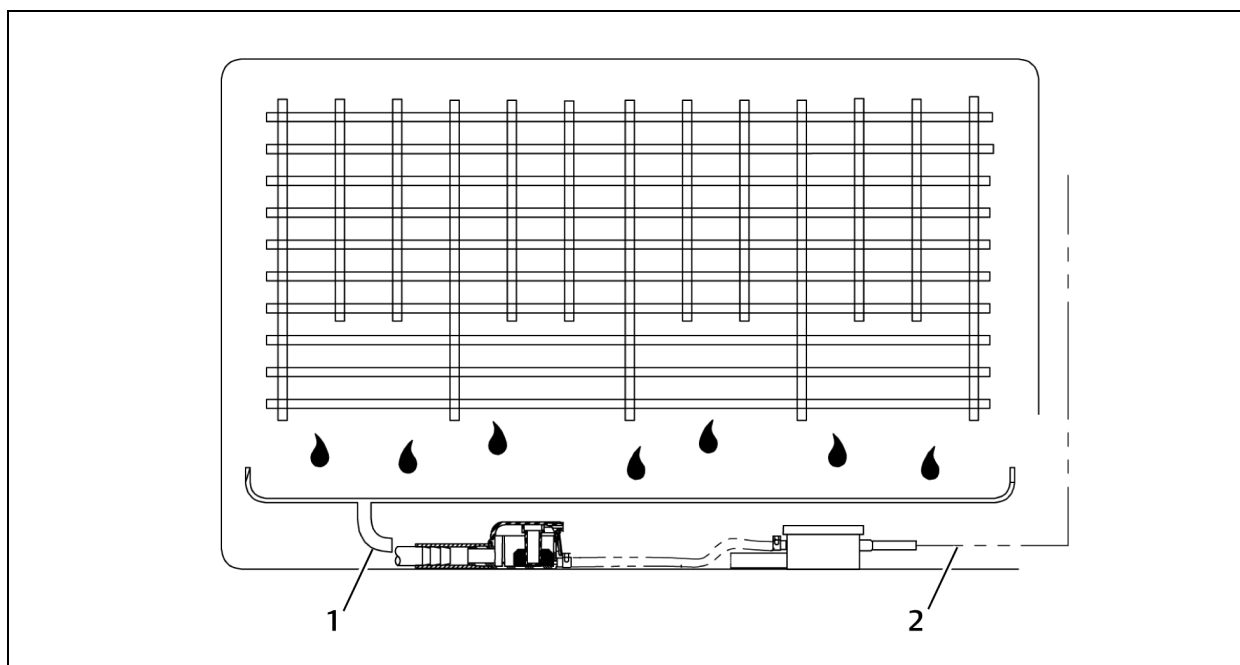

ITEM	DESCRIPTION	ITEM	DESCRIPTION
1	Drain-pan connection	2	Discharge condensate into drain

5. Using the provided Ty-Rap, mount the control unit/pump.

NOTE: The control unit/pump is not submersible. Install the control unit/pump so that water cannot drip, splash or spray onto it. Do not install the control unit/pump more than 3 ft (1 m) higher (vertically) than the collection reservoir.

6. Using the provided hose clamps, connect the tubing to from the outlet of the reservoir marked “PUMP” to the inlet of the pump (indicated by the directional arrow on the side of the pump).
7. Using a field-supplied hose clamp, attach a 5/32-in. ID tube to the discharge of the pump, and direct the other end of the discharge tubing to a gravity-feed drain.

NOTE: The maximum horizontal run is 60 ft (18 m), which results in a drop in flow rate of 10 to 15%.

NOTE: The end of the discharge tubing that is directed into the gravity-feed drain must be no more than 3 ft (1 m) below the collection reservoir. Locating the end further below creates a siphoning effect that results in noisy operation and shortens the life of the pump.

8. Connect the 4-prong plug connector cable from the reservoir into the corresponding socket on top of the to the control unit/pump, Figure 5.12 below.

Figure 5.12 Cable-connection socket on control unit/pump

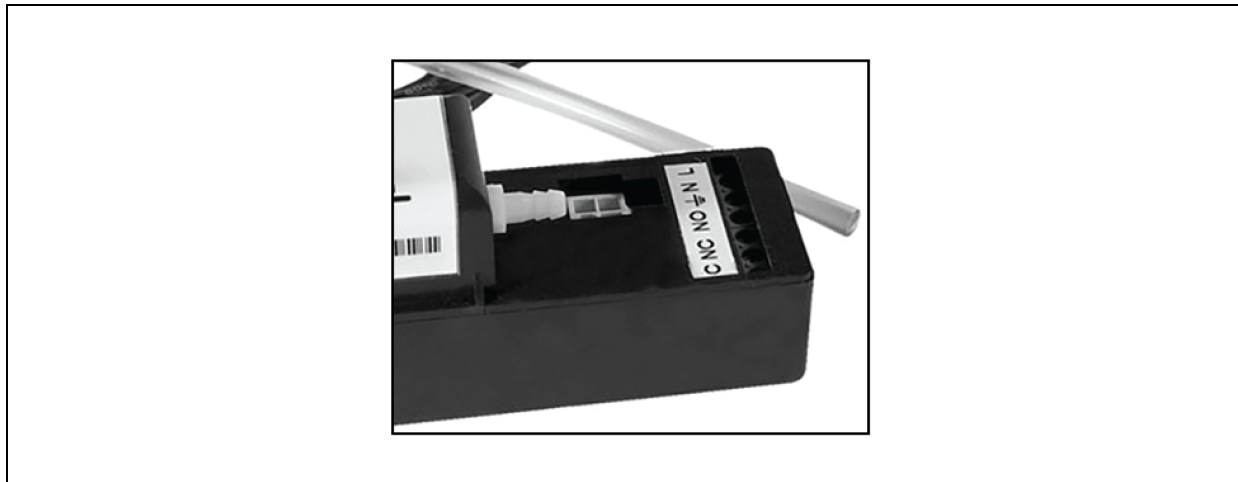

9. Referring to Table 5.2 below and Figure 5.13 on the facing page, connect the condensate pump power supply:
 - Prepare the power-supply leads by stripping approximately 1/4-in. of the lead wire insulation jacket.
 - On the terminal block, remove the screw cover to expose the set screws and confirm that the lead-wire slots are open, that is: set screws turned counterclockwise.
 - Identify the line, neutral and ground power-supply leads from the power supply.

Table 5.2 Power-supply to Control Unit Wiring

WIRE COLOR	CONNECTS TO:
Blue or White (neutral)	N
Brown or Black (line)	L
Green/Yellow or Green (ground)	ground

- Refer to the label on the control unit/pump to identify the correct terminal locations for each power-supply lead, and insert the correct lead completely into the corresponding slot of the terminal block.
- Tighten the set screw, turning clockwise, to secure the power-supply leads in place in the terminal block.
- Fit a field-supplied, 0.20-A fuse in the line lead of the cable that supplies the control unit/pump.
- Connect L1, L2, and Ground from the control unit/pump to the evaporator terminal block, Figure 5.13 on the facing page.

Figure 5.13 Power-supply wiring for the condensate pump

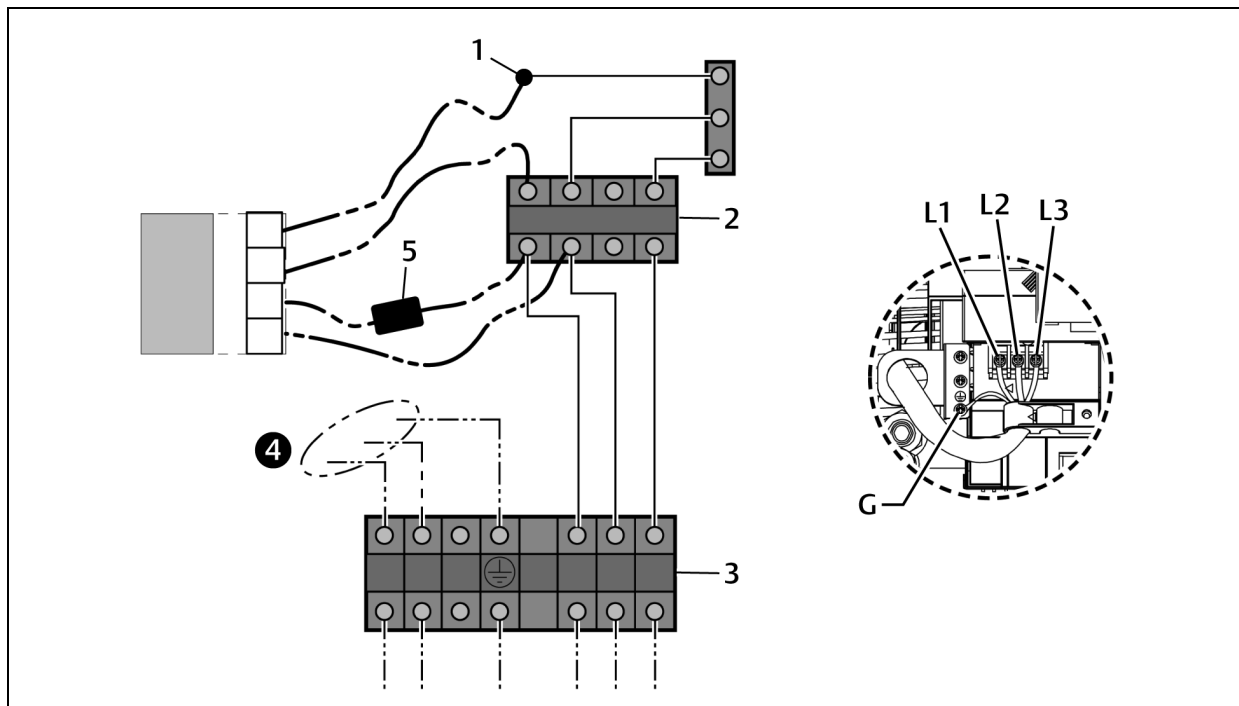

ITEM	DESCRIPTION	ITEM	DESCRIPTION
1	Butt splice	4	Power feed to outdoor unit
2	Indoor-unit terminal block	5	In-line fuse
3	Outdoor-unit terminal block		

5.3.5 Mounting the Indoor Unit to the Plate

1. Hook the indoor unit onto the upper portion of the installation plate, Figure 5.14 on the next page.
2. Engage the hooks at the top of the indoor unit with the upper edge of the installation plates.
 - Make sure that the hooks are properly seated on the installation plate by moving the unit left and right.

Figure 5.14 Hook the top of the unit to the plate

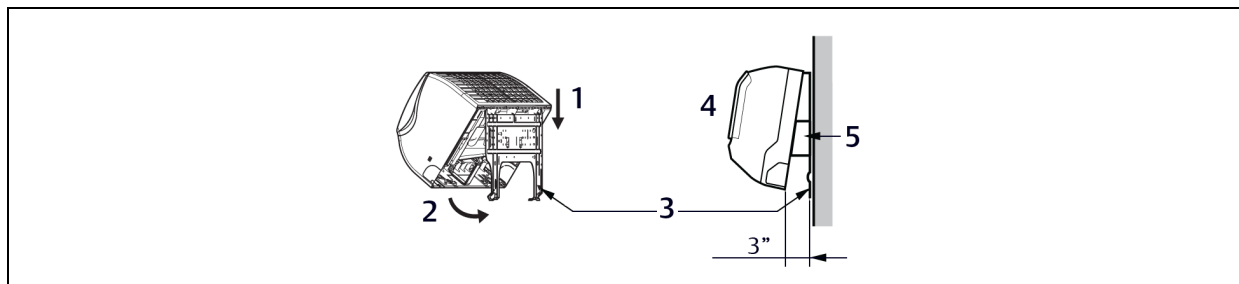

ITEM	DESCRIPTION	ITEM	DESCRIPTION
1	Hook to top of installation plate.	4	Indoor unit.
2	Move bottom of unit to install plate.	5	Spacer.
3	Installation plate.		

3. Move the bottom of the unit toward the installation plate to anchor to wall, Figure 5.15 below.
 - It helps to press the lower-left and -right sides of the unit against the installation plate until the hooks engage in their slots.
 - You will hear a clicking sound as the bottom attaches to the installation plate.

Figure 5.15 Move the bottom of the unit to the plate and attach to plate

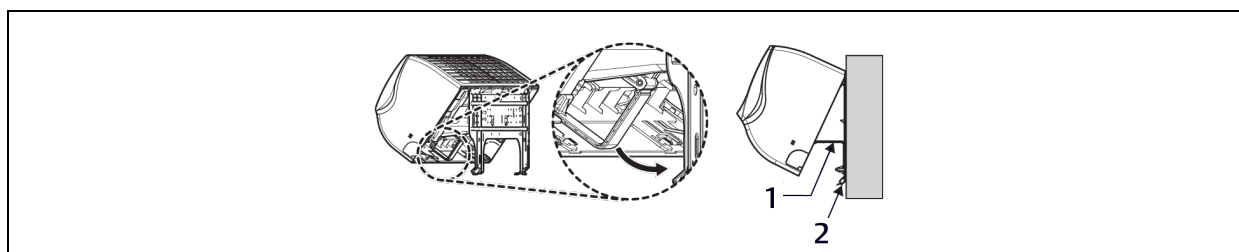

ITEM	DESCRIPTION
1	Drain-hose holder L-bracket
2	Installation plate.

4. Finish by inserting 2 type “C” screws into the bottom of the installation plate, Figure 5.16 below.
 - As you insert the screws, pay attention to the position of the piping through any wall, as shown in the figure.

Figure 5.16 Insert and tighten screws

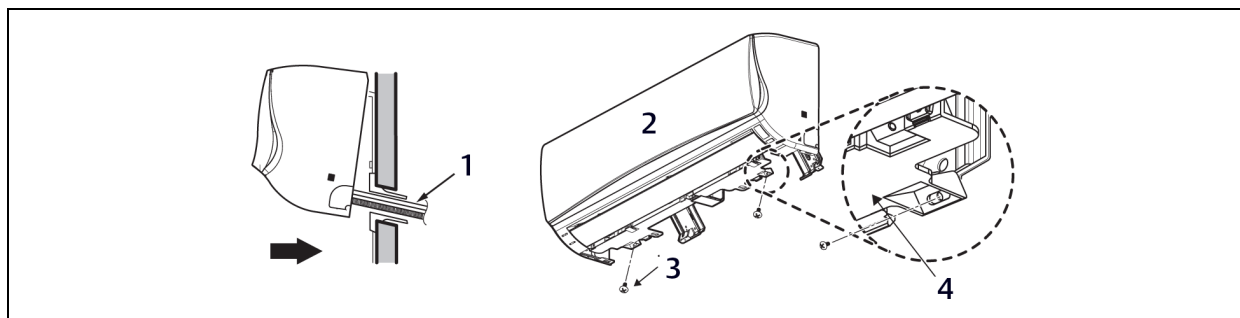

ITEM	DESCRIPTION	ITEM	DESCRIPTION
1	Piping through wall.	3	Type “C” screws.
2	Indoor unit.	4	Bottom of indoor unit.

5.3.6 Prepare for Piping/Electrical Connection

1. To prepare the indoor unit for piping, disengage the bottom on the indoor unit from the installation plate by reversing 3 of [Mounting the Indoor Unit to the Plate](#) on page 43.
 - This separates the bottom of the indoor unit from the wall mount so you can route the drain hose correctly. Figure 5.17 on the next page shows the rear view of the indoor unit.
2. Swing the drain-hose holder (L-bracket) out and anchor as show in Figure 5.15 on the previous page.
3. Refer to [Piping Requirements](#) on page 51, to continue with the piping connections to the indoor unit.

– or –

Refer to [Electrical Connections](#) on page 89, to continue with the conduit/electrical wiring to the indoor unit.

Figure 5.17 Rear view of indoor unit

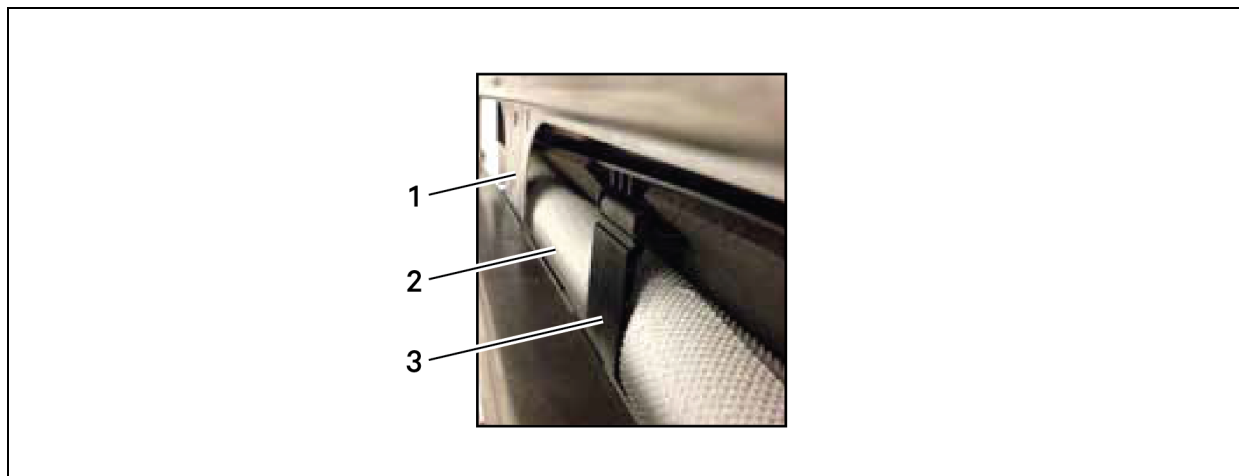

ITEM	DESCRIPTION
1	Installation plate
2	Drain hose
3	Drain-hose holder

5.4 Pump Down Procedure



CAUTION: Risk of inhalation of refrigerant gas. Can cause illness and injury. Never air purge with refrigerant as it can cause refrigerant leakage.

NOTE: Use a vacuum pump that can evacuate down to 500 microns.

1. If moisture remains in the piping after the system is evacuated for 2 hours, break the vacuum (down to 7.5 psi with nitrogen gas).
2. Evacuate the system again with the vacuum pump for at least 1 hour to 500 microns.
3. If the system does not reach 500 microns within 2 hours, repeat the vacuum break and evacuation procedure until the gauge does not rise.

This procedure is performed when a unit must be relocated or the refrigerant circuit is serviced. “Pumping down” is a term that means collecting all refrigerant into the outdoor unit without the loss of any refrigerant. Use the following procedure to safely collect refrigerant back into the outdoor unit. Always adhere to and be familiar with local codes regarding the handling of refrigerant.

The system must be placed in Cooling mode to proceed with the pump-down procedure. Refer to [Enabling Cooling-only Mode](#) on page 110, for the steps.



CAUTION: Risk of exposure or contact with refrigerant. Can cause injury and illness. Refrigerant is toxic and too cold for safe human contact. Do not inhale or handle refrigerant directly.

NOTE: Perform pump-down procedure only in cooling mode.

To perform pump down:

1. Connect a low-pressure gauge with manifold hose to the charge port on the gas-line service valve.
2. Open the gas-line service valve half-way.
3. Purge the air in the manifold hose using the refrigerant.
4. Close the liquid line service valve completely.
5. Turn on the cooling-unit's power switch and start cooling-mode operation, [Enabling Cooling-only Mode](#) on page 110.
6. Observe the pressure gauge reading.
 - When the gauge reads 1 to 0.5 kg/cm² (14.2 to 7.1 psig), fully-close the gas-line valve and immediately turn of the cooling unit.

Pump-down is complete, and all refrigerant should be collected into the outdoor unit.

This page intentionally left blank.

6 INSTALLATION CHECKLIST

Major Component Rough-in

1. Unit was connected properly per local code and the product installation procedures.
2. All literature and bagged accessories have been removed from the fan discharge.
3. Indoor unit was installed, properly supported, and located indoors in a non-corrosive environment.
4. Unit's gravity condensate drain line was connected and routed where it properly drains away or, if installed in a mechanical room, was connected and properly routed to a drain terminal.

Piping and Insulation

1. Copper
2. Over 5/8 inches—Rigid ACR only
3. 5/8 inches and under—can use soft ACR.
4. 15% silver brazing material only.
5. All refrigerant pipes and valves were insulated separately. Insulation butts up against the walls of the indoor units. No gaps or cracks. Insulation was not compressed at clamps and hangers.

Brazing Practices

1. Medical grade (there are 4 available) dry nitrogen for purging during brazing was used (constant 3 psi while brazing).

Installation

Refer to the details in the Installation section for more information on any procedure.

Refrigerant Piping

1. All pipe materials were properly stored, capped, and clean. All burrs were removed after cutting and pipe ends were reamed before brazing.
2. During refrigerant pipe installation, for each segment of pipe, a record was made of the pipe length (including expansion loops, offsets, double-back sections), and sizes, as well as the quantity and type of elbows used.
3. All long runs of straight pipe were provided with expansion loops.
4. A torque wrench and backup wrench were used to tighten all flare connections.
5. The back side of all flares were lubricated with a small drop of PVE refrigeration oil before tightening flare fittings.
6. Ensure all field-made flares are 45°. Used factory-supplied flare nuts only.
7. Pipe segments were properly supported and all wall penetrations were sleeved.
8. Pipe insulation was not compressed at any point.
9. No oil traps, solenoid valves, sight glasses, filter driers, or any other unauthorized refrigerant specialties were present.
10. Best practice including a minimum of 20-inch straight pipe was installed between each elbow.

Power Wire and Communication Cables

1. Power wiring was connected to a single-phase 208 – 230-V source.
2. Ground wire was installed and properly terminated at the unit.
3. The power supplied was clean with voltage fluctuations with specifications. ($\pm 10\%$ of nameplate).
4. Power wiring to the outdoor unit was installed per all local electrical code requirements.
5. Power wiring to the indoor unit was installed per all local electrical code requirements.
6. Factory-supplied cable was used between the indoor unit and the thermostat. No cables were spliced and no wire caps are present.
7. Communication type RS-485-BUS type.
8. All communication cables were a minimum of 18-AWG, 4 conductor, shielded, and stranded, with insulation material per local code. Cable segment shield were tied together.
9. Used appropriate crimping tool to attach ring or spade terminals at all power wiring and control cable terminations.
10. All power and control wires were properly separated using the recommended distance provided in the installation manual.

7 PIPING REQUIREMENTS

 **WARNING!** Do not allow the refrigerant to leak during brazing. If the refrigerant is combusted, it generates a toxic gas that can cause physical injury or death. Do not braze in an enclosed location, and always test for gas leaks before/after brazing. After brazing, check for refrigerant gas leaks.

- Do not use kinked pipe cause by excessive bending in one specific area on its length.
- Braze the pipes to the service-valve pipe stem of the outdoor unit.

7.1 Creating a Flare Fitting

 **WARNING!** Risk of refrigerant leaks. Can cause equipment malfunction, injury, sickness and death from suffocation due to oxygen depletion in closed, non-ventilated areas. When selecting flare fittings, always use a 45° fitting rated for use with high-pressure refrigerant R410A. Verify that all fittings comply with local, state, or federal standards.

NOTE: One of the main causes of refrigerant leaks is defective flared connections. Create flared connections using the procedure shown in Figure 7.1 on the next page and steps that follow.

Figure 7.1 Creating a flared fitting

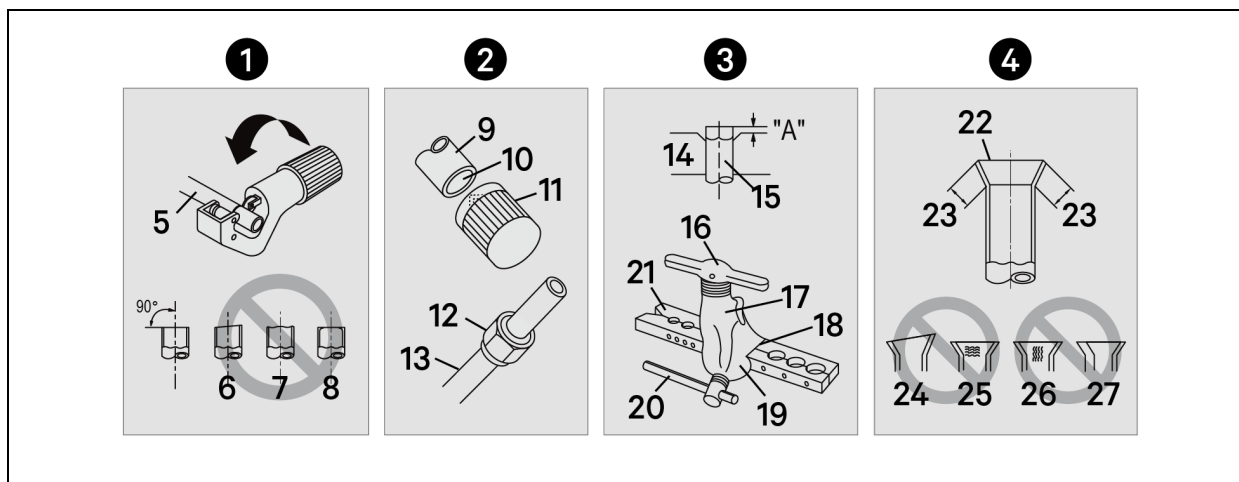

ITEM	DESCRIPTION	ITEM	DESCRIPTION
1	Copper tube	12	Cone
2	Slanted	13	Red Arrow
3	Uneven	14	Clamp handle
4	Rough	15	Copper pipe
5	Pipe	16	Smooth
6	Point down.	17	Inside shiny with no scratches.
7	Reamer	18	Even length.
8	Flare nut	19	Slanted
9	Bar	20	Damaged surface
10	Handle	21	Cracked
11	Yoke	22	Uneven thickness

To create the fitting:

1. Cut the pipe to length.
 - Measure the distance between the indoor unit and the outdoor unit.
 - Cut the pipes a little longer than the measured distance.
 - Cut the cable 4.9 ft longer than the pipe length.
2. A. Remove the burrs.
 - Completely remove all burrs from pipe ends.
 - When removing burrs, point the end of the copper pipe down to avoid introducing foreign materials into the pipe.
- B. Slide the flare nut onto the copper tube.

3. Flaring the pipe end.
 - Use the proper size flaring tool to finish flared connections as shown in Figure 7.1 on the previous page.
 - Always create a 45° flare when working with R410A. Refer to the Warning preceding this procedure.
4. Carefully inspect the flared pipe end.
 - Compare the geometry with Figure 7.1 on the previous page and the dimensions detailed in Figure 7.2 below and 7.1 on page 51.

Figure 7.2 Flared-connection dimensions

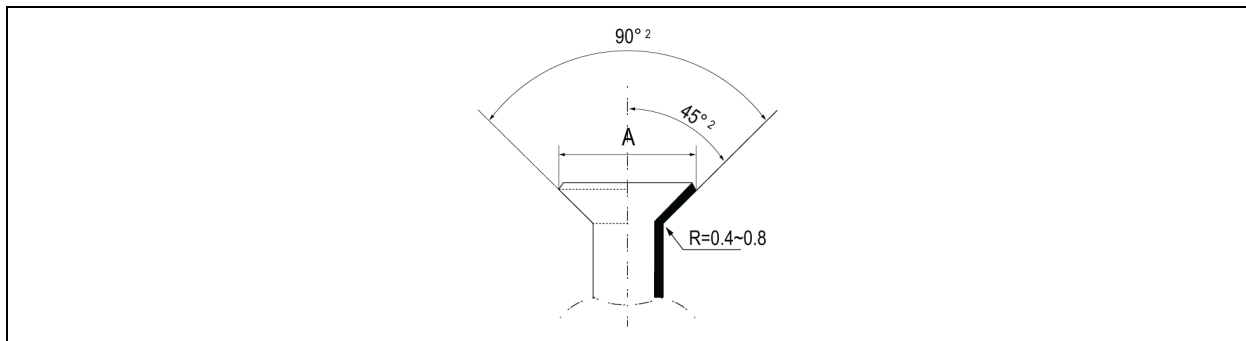

PIPE		"A"		THICKNESS	
VAPOR (IN. O.D.)	LIQUID (IN. O.D.)	VAPOR (IN.)	LIQUID (IN.)	VAPOR (IN.)	LIQUID (IN.)
1/2	1/4	1/8	1/16	1/8	1/8
5/8	3/8	1/8	1/16	1/16	1/8

7.2 Tightening Flare Nuts

NOTE: Do not use polyolyester (POE) or any other type of mineral oil as a thread lubricant. These lubricants are not compatible with PVE oil used in this system and create oil sludge leading to equipment damage and system malfunction.

1. When connecting the flare nuts, coat the flare (inside and outside) with polyvinyl ether (PVE) refrigeration oil only.
2. Initially, hand tighten the flare nuts using 3 or 4 turns.
3. Finishing tightening the flare nuts using both a torque wrench and a backup wrench as shown in Figure 7.3 on the next page.

Table 7.1 Tightening torque for flare nuts

PIPE SIZE (IN. O.D.)	TIGHTENING TORQUE (FT-LBS)	WIDTH OF FLARE (A [IN.])
1/4Ø	13.9 - 18	1/8
3/8Ø	24.5 - 30.3	1/8
1/2Ø	39.7 - 47.7	1/8
5/8Ø	45.5 - 59.2	1/16

Figure 7.3 Tightening the flare nuts

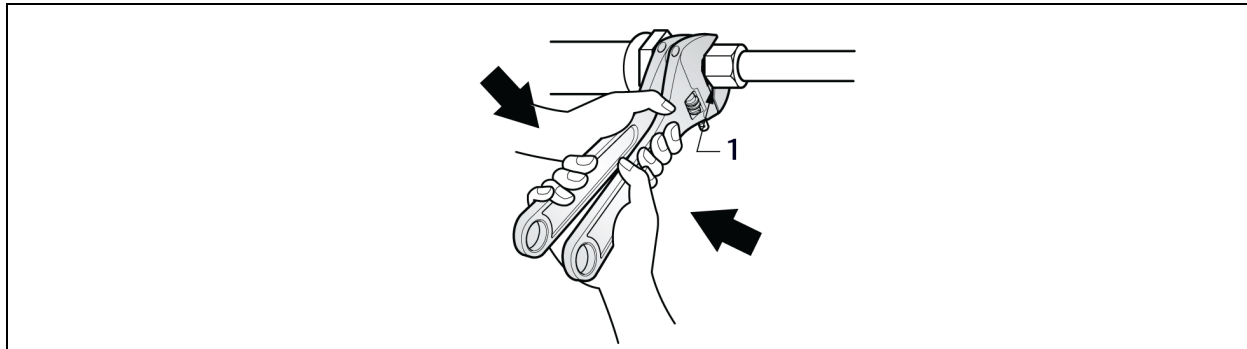

ITEM	DESCRIPTION
1	Union.

7.2.1 Loosening Flare Nuts

Always use 2 wrenches to loosen the flare nuts.

7.3 Piping Materials and Handling

Pipes used for the refrigerant piping system must include the specified thickness, and the interior must be clean.

While handling and storing, do not bend or damage the pipes, and take care not to contaminate the interior with dust, moisture, etc. See Table 7.2 on the facing page for care of piping.

Figure 7.4 Keep piping capped while storing

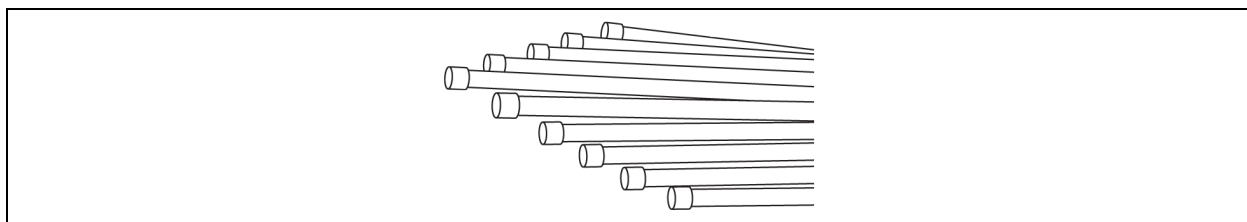
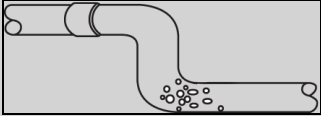
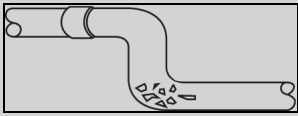



Table 7.2 Three principles of refrigerant piping

	DRY	CLEAN	AIRTIGHT
Principles	No moisture should be inside the piping. 	No dust should be inside the piping. 	No leaks should occur. 
Problems Caused	<ul style="list-style-type: none"> Significant hydrolysis of refrigerant oil. Refrigerant oil degradation. Poor insulation of the compressor. System does not operate properly. EEVs, capillary tubes are clogged. 	<ul style="list-style-type: none"> Refrigerant oil degradation. Poor insulation of the compressor. System does not operate properly. EEVs and capillary tubes become clogged. 	<ul style="list-style-type: none"> Refrigerant gas leaks/shortages. Refrigerant oil degradation. Poor insulation of the compressor. System does not operate properly.
Solutions	<ul style="list-style-type: none"> Remove moisture from the piping. Piping ends should remain capped until connections are complete. Do not install piping on a rainy day. Connect piping properly at the unit's side. Remove caps only after the piping is cut, the burrs are removed, and after passing the piping through the walls. Evacuate system to a minimum of 500 microns and ensure the vacuum holds at that level for 24 hours. 	<ul style="list-style-type: none"> Remove dust from the piping. Piping ends should remain capped until connections are complete. Connect piping properly at the side of the unit. Remove caps only after the piping is cut and burrs are removed. Retain the cap on the piping when passing it through walls, etc. 	<ul style="list-style-type: none"> Test system for airtightness. Perform brazing procedures that comply with all applicable standards. Perform flaring procedures that comply with all applicable standards. Perform flanging procedures that comply with all applicable standards. Ensure that refrigerant lines are pressure-test to 550 psig.

7.3.1 Brazing Practices

IMPORTANT! It is imperative to keep the piping system free of contaminants and debris such as copper burrs, slag, or carbon dust during installation. Contaminants can result in mechanical failure of the system.

All joints are brazed in the field. Refrigeration-system components contain very small capillary tubes, small orifices, electronic expansion valves, oil separators, and heat exchangers that can easily become blocked. Proper system operation depends on the installer using best practices and utmost care while assembling the piping system.

Figure 7.5 Refrigerant-pipe brazing

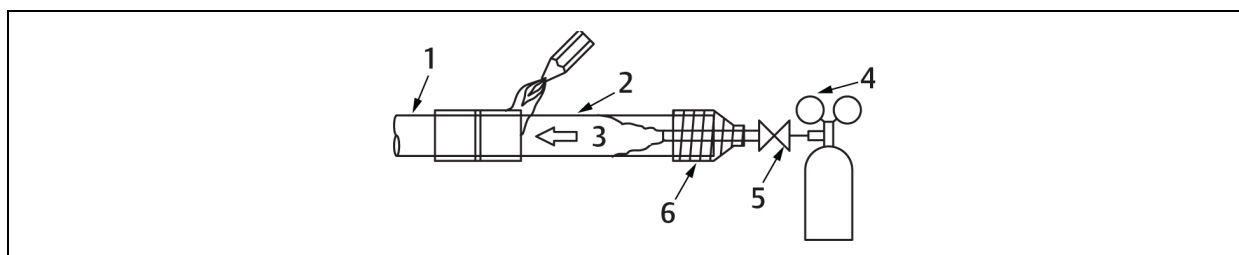

ITEM	DESCRIPTION	ITEM	DESCRIPTION
1	Refrigerant piping	4	Pressure-reducing valve
2	Pipe to be brazed	5	Valve
3	Nitrogen	6	Taping

- While brazing, use a dry-nitrogen purge operating at a minimum pressure of 3 psig and maintain a steady flow.
- Before assembly, use dry nitrogen to blow clean all pipe sections.
- Use a tubing cutter, do not use a saw to cut pipe. De-burr and clean all cuts before assembly.
- Store pipe stock in a dry place. Keep pipe capped and clean.
- Use adapters to assemble different sizes of pipe.
- Do not use flux, soft solder, or anti-oxidant agents.
- Use a 15% silver phosphorous copper-brazing alloy to avoid overheating and produce good flow.
- Protect isolation valves, electronic expansion valves, and other heat-sensitive control components from excessive heat with a wet rag or a heat-barrier spray product.

7.3.2 Refrigerant-piping Insulation Guidelines

All refrigerant piping, field-provided isolation ball valves, service valves, and elbows shall be completely insulated using closed-cell pipe insulation. The liquid and vapor lines must be insulated separately.

To prevent heat loss/heat gain through the refrigerant piping, all refrigerant piping, including liquid lines and vapor lines shall be insulated separately. Insulation shall be a minimum 1/2-in. thick, and thickness may need to be increased based-on ambient conditions and local codes.

All insulation joints shall be glued with no air gaps. Insulation material shall fit snugly against the refrigeration pipe with no air space between it and the pipe. Insulation passing through pipe hangers, inside conduit, and/or sleeves must not be compressed. Protects insulation inside hangers and supports with a second layer. All pipe insulation exposed to the sun and outdoor elements shall be properly protected with PVC, aluminum vapor barrier, or alternatively placed in a weather-resistant enclosure such as a pipe rack with a top cover and meet local codes.

The design engineer should perform calculations to determine if the factory-supplied insulation jackets are sufficient to meet local codes and avoid sweating. Add additional insulation if necessary. Mark all pipes at the point where the insulation jacket ends. Remove the jacket. Install field-provided insulation on the run-out and main-trunk pipes first. Peel the adhesive glue protector slip from the insulation jacket and install the clam-shell jacket over the fitting.

For specific insulation procedures, see [Insulating Refrigeration Piping](#) on page 79.

7.3.3 Selecting Field-supplied Copper Tubing

Copper is the only approved refrigerant-pipe material for use with the Liebert SRC, and we recommend seamless phosphorous deoxidized ACR type copper pipe, hard-drawn rigid type “K” or “L,” or annealed-tempered, copper pipe.

- Drawn temper (rigid) ACR copper tubing is available in sizes 3/8 through 2-1/8 inches (ASTM B 280, clean, dry, and capped).
- Annealed temper (soft) ACR copper tubing is available in sizes 1/4 through 2-1/8 inches (ASTM B 280, clean, dry, and capped).

Tube wall thickness should meet local code requirements and be approved for an operating pressure of 551 psi. If local code does not specify wall thickness, We suggest using tube thickness per Table 7.3 below. When bending tubing, try to keep the number of bends to a minimum, and use the largest radii possible to reduce the equivalent length of installed pipe. Also, bending radii greater than 10 pipe diameters can minimize pressure drop. Be sure that no traps or sags are present when rolling-out soft copper-tubing coils.

NOTE: Commercially-available piping often contains dust and other materials. Always blow it clean with a dry, inert gas. Prevent dust, water or other contaminants from entering the piping during installation. Contaminants can cause mechanical failure.

Table 7.3 ACR copper-tubing material

SPECIFICATIONS	DESCRIPTIONS
Type	Seamless phosphorous deoxidized
Class	UNS C12200 DHP
Straight Lengths	H58 temper
Coils	O60 temper

Table 7.4 Piping-tube thickness

SPECIFICATIONS	DESCRIPTIONS/MEASUREMENTS								
OD (in.)	1/4	3/8	1/2	5/8	3/4	7/8	1-1/8	1-3/8	1-5/8
Material	Rigid type "K" or "L" and a soft ACR acceptable				Rigid type "K" or "L" only				
Min. Bend Radius (in.)	.563	.9375	1.5	2.25	3.0	3.0	3.5	4.0	4.5
Min. Wall Thickness (in.)	.03	.03	.035	.040	.042	.045	.050	.050	.050

Table 7.5 ACR copper-tubing dimensions and physical characteristics¹⁻⁴

NOMINAL PIPE OUTSIDE DIAMETER (IN.)	ACTUAL OUTSIDE DIAMETER (IN.)	DRAWN TEMPER			ANNEALED TEMPER		
		NOMINAL WALL THICKNESS (IN.)	WEIGHT (LB/FT)	CUBIC FT PER LINEAR FT	NOMINAL WALL THICKNESS (IN.)	WEIGHT (LB/FT)	CUBIC FT PER LINEAR FT
1/4	0.250	–	–	–	0.030	0.081	.00020
3/8	0.375	0.030	0.126	.00054	0.032	0.134	.00053
1/2	0.500	0.035	0.198	.00101	0.032	0.182	.00103
5/8	0.625	0.040	0.285	.00162	0.035	0.251	.00168
3/4	0.750	0.042	0.362	.00242	0.042	0.362	.00242
7/8	0.875	0.045	0.455	.00336	0.045	0.455	.00336
1-1/8	1.125	0.050	0.655	.00573	0.050	0.655	.00573

1. All dimensions provided are in accordance with ASTM B280 - Standard.
2. Design pressure = 551 psig.
3. ACR tubing is available as hard-drawn or annealed (soft) and are suitable for use with R410A refrigerant.
4. The Copper Tube Handbook, 2010, Copper Development Association Inc., 260 Madison Avenue, New York, NY 10016.

7.3.4 No Pipe Size Substitutions

Use only the pipe size recommended by this manual. Using a different size is prohibited and may result in a system malfunction or failure to work at all.

7.3.5 Obstacles

When an obstacle, such as an I-beam or concrete T, is in the path of the planned refrigerant-pipe run, it is best practice to route the pipe over the obstacle. If adequate space is not available to route the insulated pipe over the obstacle, then route the pipe under the obstacle. In either case, it is imperative that the length of the horizontal section of pipe above or below the obstacle be a minimum of 3-times the longest vertical rise (or fall) at either end of the segment, Figure 7.6 on the facing page.

Figure 7.6 Installing piping above and below an obstacle

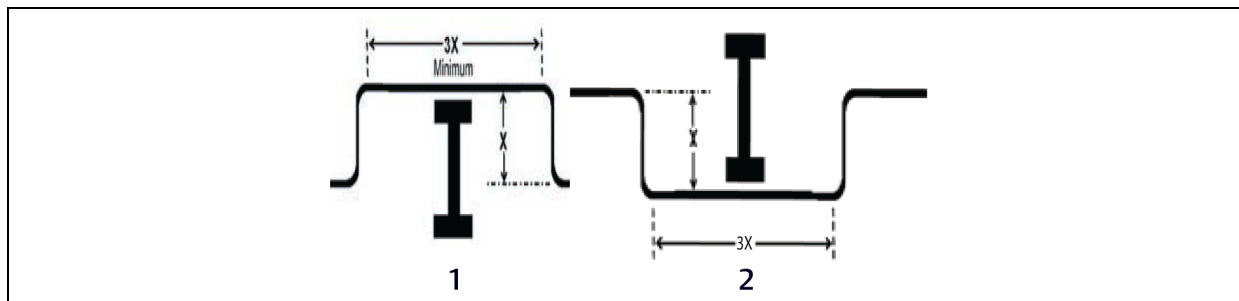

ITEM	DESCRIPTION
1	Above an obstacle
2	Below an obstacle

7.3.6 Copper Expansion and Contraction

Under normal operating conditions, the vapor pipe temperature of a Liebert SRC can vary as much as 280°F. With this large variance in pipe temperature, the designer must consider pipe expansion and contraction to avoid pipe and fitting fatigue failures.

Refrigerant pipe along with the insulation jacket form a cohesive unit that expands and contracts together. During system operation, thermal heat transfer occurs between the pipe and the surrounding insulation.

If the pipe is mounted in free-air space, no natural restriction to movement is present, if the mounting clips are properly spaced and installed. When the refrigerant pipe is mounted underground in a utility duct, stacked among other pipes, natural restriction to linear movement is present. In extreme cases, the restrictive force of surface friction between insulation jackets could become so great that natural expansion ceases and the pipe is “fixed” in place. In this situation, opposing force caused by change in refrigerant fluid/vapor temperature can lead to stress failure of pipes/fittings.

The refrigerant-pipe support system must be engineered to allow free expansion to occur. When a segment of pipe is mounted between two fixed points, provisions must be provided to allow pipe expansion to naturally occur. The most common method is the inclusion of expansion loops or U-bends. Each segment of pipe has a natural fixed point where no movement occurs. This fixed point is located at the center point of the segment assuming that the entire pipe is insulated in a similar fashion. The natural fixed point of the pipe segment is typically where the expansion loop or U-bend should be.

Linear pipe expansion can be calculated using the following formula:

$$LE = C \times L \times (Tr - Ta) \times 12$$

- LE = Anticipated linear tubing expansion (in.)
- C = Constant (for copper = 9.2×10^{-6} in./in.°F)
- L = Length of pipe (ft)
- Tr = Refrigerant-pipe temperature (°F)
- Ta = Ambient air temperature (°F)
- 12 = Inches-to-feet conversion (12 in./ft)

To calculate the expansion

1. From Table 7.6 below, find the row corresponding with the actual length of the straight pipe segment.
2. Estimate the minimum and maximum temperature of the pipe.
In the column showing the minimum pipe temperature, look up the anticipated expansion distance. Do the same for the maximum pipe temperature.
3. Calculate the difference in the two expansion distance values.
The result is the anticipated change in pipe length.

Table 7.6 Linear thermal expansion of copper tubing, in inches

PIPE LENGTH*	FLUID TEMPERATURE, °F									
	35°	40°	45°	50°	55°	60°	65°	70°	75°	80°
10	0.04	0.04	0.05	0.06	0.06	0.07	0.08	0.08	0.09	0.09
20	0.08	0.08	0.10	0.12	0.13	0.14	0.15	0.16	0.17	0.18
30	0.12	0.12	0.15	0.18	0.20	0.21	0.23	0.24	0.26	0.27
40	0.16	0.16	0.20	0.24	0.26	0.28	0.30	0.32	0.34	0.36
50	0.20	0.20	0.25	0.30	0.33	0.35	0.38	0.40	0.43	0.45
60	0.24	0.24	0.30	0.36	0.39	0.42	0.45	0.48	0.51	0.54
Pipe Length*	Fluid Temperature, °F									
	85°	90°	95°	100°	105°	110°	115°	120°	125°	130°
10	0.10	0.10	0.11	0.11	0.11	0.12	0.13	0.14	0.15	0.15
20	0.19	0.20	0.21	0.22	0.22	0.23	0.26	0.28	0.29	0.30
30	0.29	0.30	0.32	0.33	0.32	0.35	0.39	0.42	0.44	0.45
40	0.38	0.40	0.42	0.44	0.43	0.46	0.52	0.56	0.58	0.60
50	0.48	0.50	0.53	0.55	0.54	0.58	0.65	0.70	0.73	0.75
60	0.57	0.60	0.63	0.66	0.65	0.69	0.78	0.84	0.87	0.90

*Pipe length baseline temperature = 0°F. "Expansion of Carbon, Copper and Stainless Steel Pipe," *The Engineer's Toolbox*, www.engineeringtoolbox.com.

Example:

A system is installed and the design shows that there is a 100-foot straight segment of tubing between an indoor unit and the outdoor unit. When heating, this pipe transports hot gas vapor to the indoor units at 120°F. When cooling, the same tube is a suction line that returns refrigerant vapor to the outdoor unit at 40°F. Look-up the copper-tubing expansion at each temperature and calculate the difference.

Vapor:

- Transporting hot vapor: 100-ft pipe at 120°F = 1.40 in.
- Transporting suction vapor: 100-ft pipe at 40°F = 0.40 in.
- Anticipated change in length: 1.40 in. – 0.40 in. = 1.00 in.

Liquid Line:

- The liquid temperature remains relatively the same temperature, only direction of flow reverses. Therefore, no significant change in length of the liquid line is anticipated.
- When creating an expansion joint, the joint height should be a minimum of two times the joint width. Although different types of expansion arrangements are available, the data for correctly sizing an expansion loop is provided in Table 7.7 below. Use soft copper with long-radius bends on longer runs or long-radius elbows for shorter pipe segments. Using the anticipated linear expansion (LE) distance calculated, look-up the expansion loop or U-bend minimum design dimensions. If you choose to use other types of expansion joints, design per ASTM B-88 Standards.

Figure 7.7 Coiled expansion loops and offsets

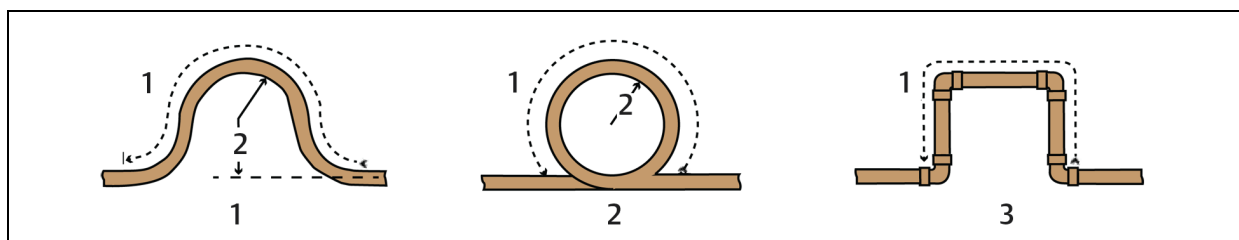

NO.	DESCRIPTION	NO.	DESCRIPTION
1	Length (L)	1	Large tubing U-bend (greater than 3/4 in.)
2	Radii (R)	2	Loop
		3	Small tubing U-bend (less than 3/4 in.)

Table 7.7 Radii of coiled expansion loops and developed lengths of expansion offsets

ANTICIPATED LINEAR EXPANSION (LE) (IN.)		NOMINAL TUBE SIZE (OD) IN.			
		1/4	3/8	1/2	3/4
1/2	R1	6	7	8	9
	L2	38	44	50	59
1	R1	9	10	11	13
	L2	54	63	70	83
1-1/2	R1	11	12	14	16
	L2	66	77	86	101
2	R1	12	14	16	19
	L2	77	89	99	117
2-1/2	R1	14	16	18	21
	L2	86	99	111	131
3	R1	15	17	19	23
	L2	94	109	122	143
3-1/2	R1	16	19	21	25
	L2	102	117	131	155
4	R1	17	20	22	26
	L2	109	126	140	166

7.3.7 Pipe Bends

When bending soft copper, use long-radius bends. Refer to Table 7.7 on the previous page for minimum radius specifications.

7.3.8 In-line Refrigeration Components

Components such as oil traps, solenoid valves, filter-dryers, sight glasses, tee fittings, and other after-market accessories are not permitted on the refrigerant-piping system between the outdoor unit and the indoor unit.

Liebert SRC systems are provided with redundant systems that assure oil is properly returned to the compressor. Sight glasses and solenoid valves may cause vapor to form in the liquid stream.

Over time, dryers may deteriorate and introduce debris into the system. The designer and installer should verify that the refrigerant-piping system is free of traps, sagging pipes, sight glasses, filter dryers, etc.

7.3.9 Field-provided Isolation Ball Valves

Vertiv™ allows the installation of field-supplied ball valves with Schrader ports at each indoor unit. Full-port isolation ball valves with Schrader ports (positioned between valve and indoor unit) rated for use with R410A refrigerant should be used on both the liquid and vapor lines.

If valves are not installed and a single indoor unit must be removed or repaired, the entire system must be shut down and evacuated. Position valves with a minimum distance of 3 to 6 inches of pipe on either side of the valve, and placed between 6 and 12 inches from the run-out pipe to the upstream main pipe. If ball valves are installed closer than this to the indoor unit, a section of pipe becomes a dead zone where oil may accumulate when the valves are closed.

7.3.10 Using Elbows

Field-supplied elbows are allowed as long as they are designed for use with R410A refrigerant. The designer, however, should be cautious with the quantity and size of fittings used, and must account for the additional pressure losses in equivalent-pipe-length calculation.

The equivalent pipe length of each elbow must be added to each pipe segment, Table 7.8 below.

Table 7.8 Equivalent piping length for piping components

COMPONENT	SIZE (IN.)				
Elbow (ft)	1/4	3/8	1/2	5/8	3/4
	0.5	0.6	0.7	0.8	1.2

7.3.11 Pipe Supports

NOTE: A properly-installed pipe system should be adequately supported to avoid pipe sagging. Sagging pipes become oil traps that lead to equipment malfunction.

Pipe supports should never touch the pipe wall. Insulate the pipe first because pipe supports must be install outside (around) the primary pipe-insulation jacket, Figure 7.8 on the facing page. Use Clevis hangers with shield between the hangers and insulation. Field-provided pipe supports should be designed to meet local codes. If allowed by code, use fiber straps or split-ring hangers suspended from the ceiling on all-thread rods (fiber straps or split-ring hangers may be used as long as they do not compress the pipe insulation). Place a second layer of insulation of the pipe-insulation jacket to prevent chafing and compression of the primary insulation withing the confines of the support-pipe clamp.

Figure 7.8 Pipe-hanger details

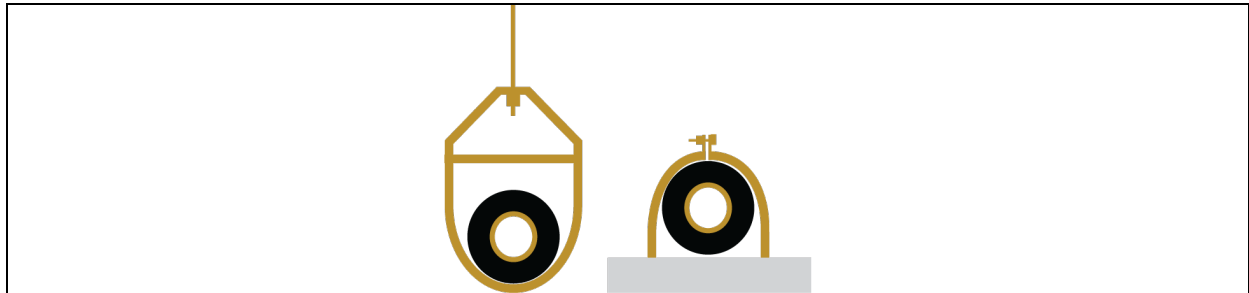

A properly-installed pipe system has sufficient supports to prevent pipes from sagging during the life of the system. As necessary, place supports closer for segments where potential sagging could occur. Maximum spacing of the pipe supports must meet local codes.

If local codes do not specify pipe-support spacing, support the pipes as follows:

- Maximum of 5 feet on center for straight segments of pipe up to 3/4-in. outside diameter.
- Maximum of 6 feet on center for pipe up to 1-in. outside diameter.
- Maximum of 8 feet on center for pipe up to 2-in. outside diameter.

Wherever the pipe changes direction, place pipe clamps within 12 inches on one side and within 12 to 19 inches of bend on the other side, as shown in Figure 7.9 below.

Figure 7.9 Typical pipe-support location for a change in pipe direction

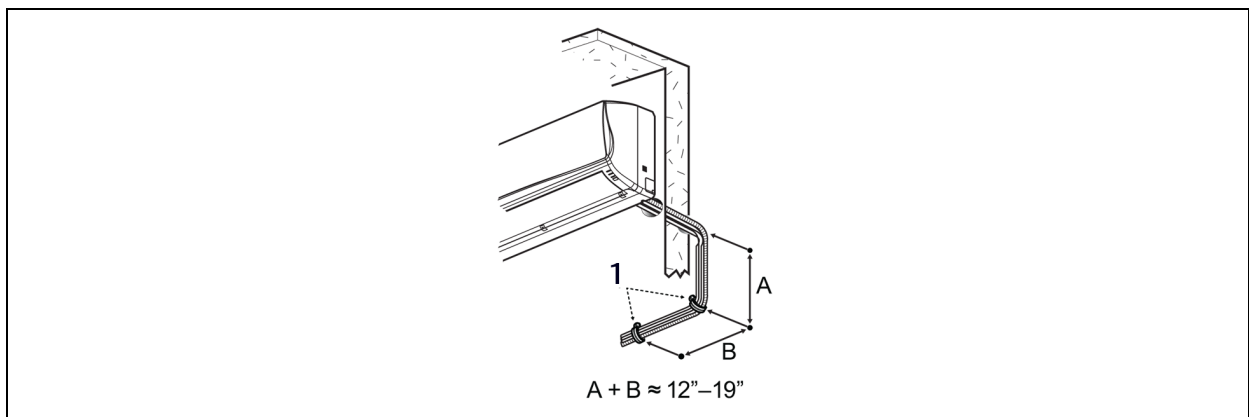

ITEM	DESCRIPTION
1	Pipe clamps

7.3.12 Pipe Sleeves at Penetrations

All pipe penetrations through walls, floors, and pipes buried underground must be properly-insulated and routed through an appropriate wall sleeve of sufficient size to prevent compression of refrigerant-pipe insulation and free movement of the pipe with the sleeve, Figure 7.10 below.

NOTE: When filling an access hole with mortar, cover the area with steel plate so that the insulation will not fall through. For this area, use fire-resistant materials for both the insulation and cover. (Do not use a vinyl cover.)

NOTE: The diameter of the penetrations must be determined by the pipe diameter plus the thickness of the insulation.

Figure 7.10 Pipe sleeve options

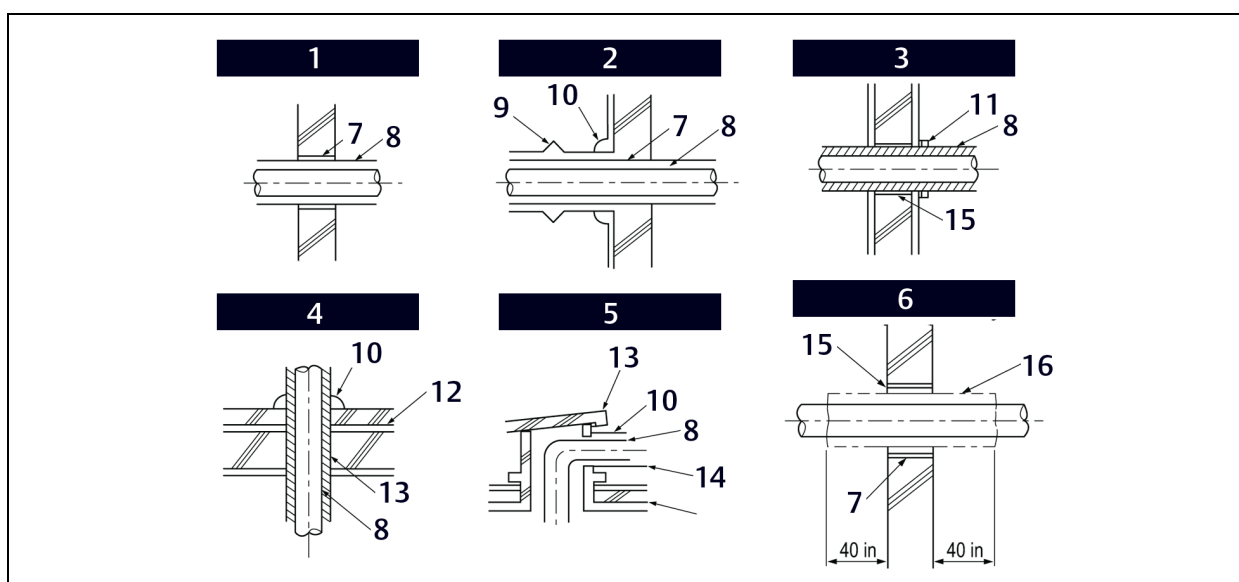

ITEM	DESCRIPTION	ITEM	DESCRIPTION
1	Inside wall (concealed)	9	Lagging
2	Outside wall	10	Caulk
3	Outside wall (exposed)	11	Band
4	Floor (fire-resistance)	12	Water-resistant layer
5	Roof pipe shaft	13	Sleeve with edge
6	Area between fire-resistant insulation and boundary wall	14	Lagging
7	Sleeve	15	Mortar or other fire-resistant caulk
8	Insulation	16	Fire-resistant insulation

7.3.13 Underground Refrigerant Piping

Refrigerant pipe installed underground should be routed inside a vapor-tight protective sleeve to prevent deterioration of the insulation and water infiltration. Refrigerant pipe installed inside underground casing must be continuous without any joints. Underground refrigerant pipe must be located at a level **below the frost line**.

Figure 7.11 below shows the arrangement of refrigerant pipe and cable(s) in a conduit. 7.3.13 above shows conduit sizes for utility conduit.

Figure 7.11 Typical arrangement of pipe and cables in a utility conduit

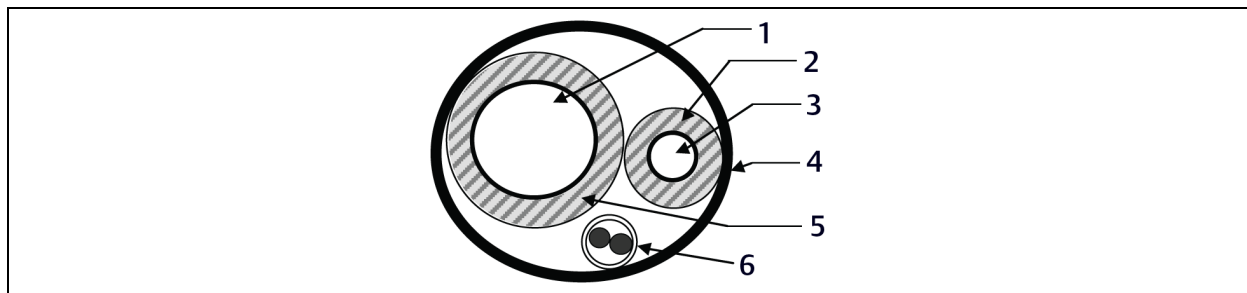

ITEM	DESCRIPTION	ITEM	DESCRIPTION
1	Vapor line	4	Pipe sleeve
2	Insulation material	5	Insulation material
3	Liquid line	6	Min. 18-gauge power/communication cable

Table 7.9 Utility-Conduit Sizes

SPECIFICATIONS	LIQUID PIPE		VAPOR PIPE	
	OD Pipe Diameter	3/8 in.		3/8 in.
Diameter of pipe w/ insulation	N/A		1-1/8 in.	2-1/8 in.
Insulation Thickness	3/8 in		1 in.	1 in.

NOTE: Thickness of pipe insulation is typical. Actual required thickness may vary based on surrounding ambient conditions and should be calculated and specified by the design engineer.

Table 7.10 Heat-pump unit refrigerant-pipe connections (All brazed type)

MODEL	LIQUID CONN., IN.	VAPOR CONN., IN.
SCR18, 24, 36	3/8	5/8

7.4 Piping Connections

7.4.1 Connection Limitations

Liebert SRC systems consist of one outdoor unit and one indoor unit. One of the most critical elements of a system is the refrigerant piping. Table 7.11 below, lists pipe-length limits that must be followed in the design of an SRC system. See Figure 7.12 below for maximum length and elevation of piping.

Table 7.11 Refrigerant-Piping System Limitations

SPECIFICATIONS	LIMITATIONS	SRC18	SRC24	SRC36
Longest total equivalent piping length	Longest total equivalent piping length	98.4 ft.	164.0 ft.	164.0 ft.
	Shortest total equivalent piping length	9.8 ft.	9.8 ft.	9.8 ft.
	Distance between fittings and indoor units or outdoor units	≥20 in.	≥20 in	≥20 in.
Elevation	If outdoor unit is above indoor unit.	49.2 ft.	98.4 ft.	98.4 ft.
	If outdoor unit is below indoor unit.	49.2 ft.	98.4 ft.	98.4 ft.
Additional refrigerant needed (oz/ft)		0.22 oz.	0.38 oz.	0.38 oz.

Figure 7.12 System piping layout

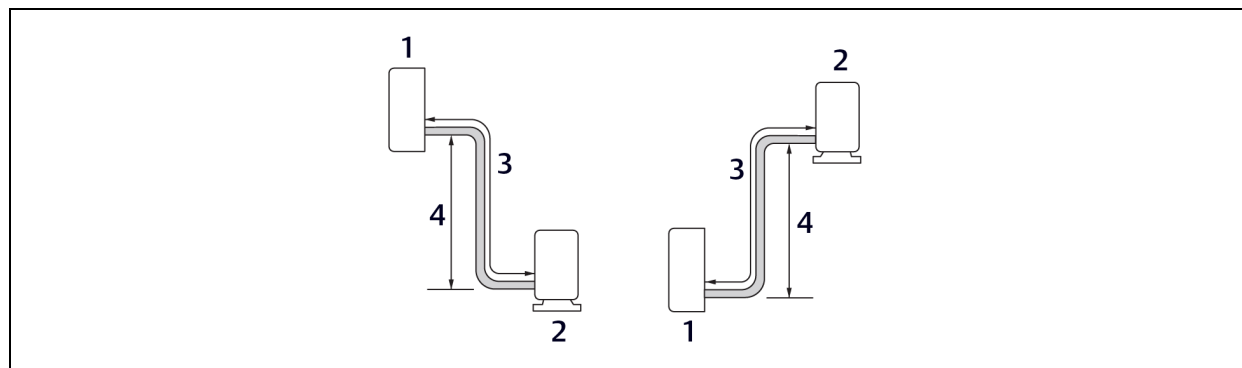

TABLE	DESCRIPTION	TABLE	DESCRIPTION
1	Indoor unit	3	Maximum length
2	Outdoor unit	4	Maximum elevation

7.4.2 Piping Connections Layout

Liebert SRCs are a 1-to-1 system. There is a direct piping connection between the outdoor unit and the indoor unit. Figure 7.13 on the facing page, illustrates the basic pipe connections between the outdoor and indoor unit. Refer back to this illustration as you proceed with pipe connection. Figure 7.13 on the facing page, shows the indoor unit installed at a higher position than the outdoor unit. However, if you install the outdoor unit in a higher position than the indoor units, the basic pipe connections still apply.

Refer to for specific length limitations on indoor- and outdoor-unit positioning.

Figure 7.13 Piping installation and connection overview

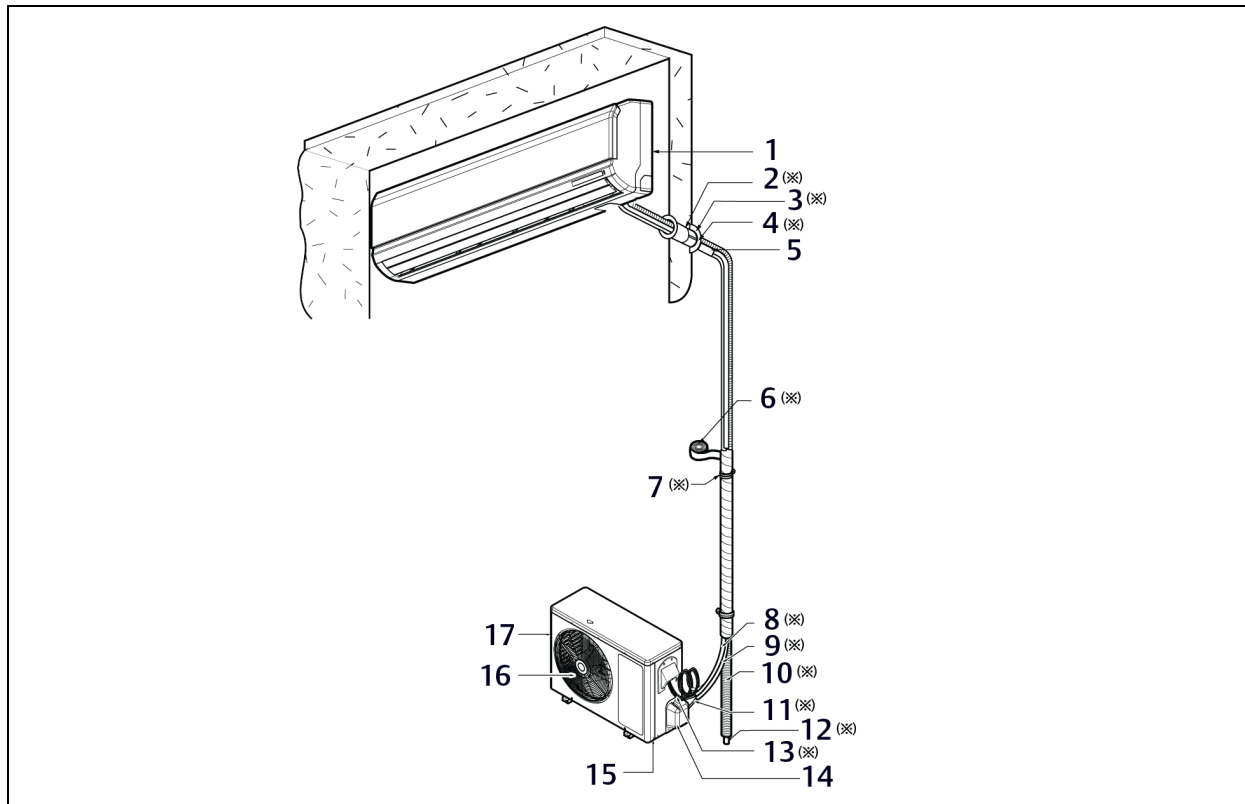

ITEM	DESCRIPTION	ITEM	DESCRIPTION
1	Installation plate	10	Additional drain pipe
2	Sleeve	11	Vinyl tape (narrow)
3	Bushing-sleeve	12	Drain hose
4	Putty (gum-type sealant)	13	Connecting cable
5	Bend the pipe as closely on the wall as possible, but be careful that it doesn't break.	14	Tubing cover
6	Vinyl tape (wide) Apply after carrying-out a drainage test.	15	Base plate
7	Saddle	16	Air outlet
8	Gas-side piping	17	Air inlet
9	Liquid-side piping		

NOTE: As you proceed with the piping connections, be sure to adhere to the pipe-support spacing as shown in Figure 7.14 on the next page. Refer to [Pipe Supports](#) on page 62, for more information about using elbows, clamps and pipe-support materials. Always follow state and local codes for piping and accurate support-spacing along the outdoor pipe line.

Figure 7.14 Pipe-support spacing for outdoors

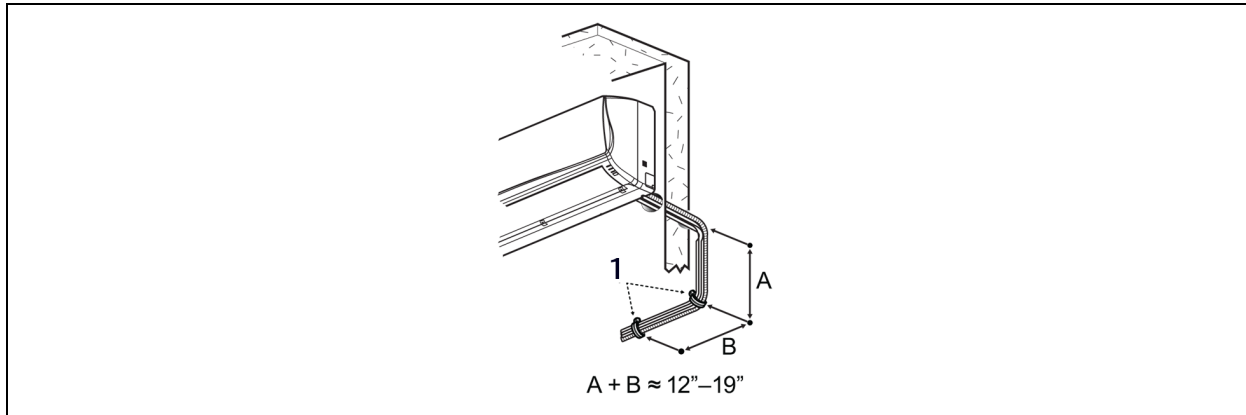

ITEM	DESCRIPTION
1	Pipe clamps

Pipe Bundling

Refer to Figure 7.15 below, for proper cable and pipe bundling. Note the placement of the piping along with the necessary insulation material.

Figure 7.15 Proper pipe and cable bundling—cut-away

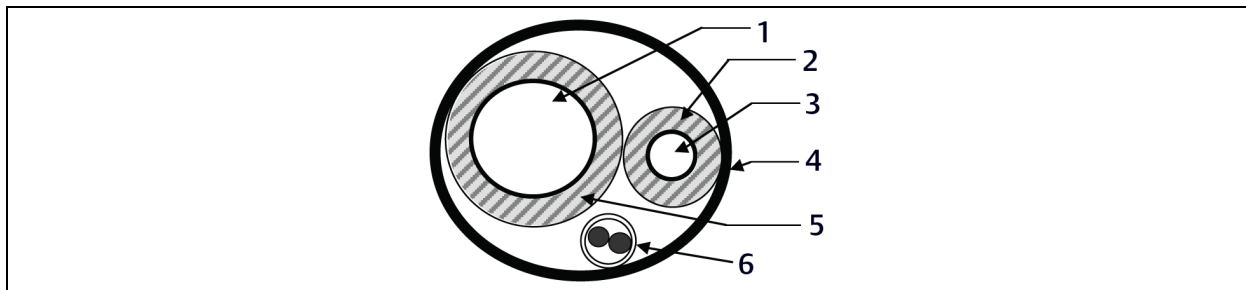

ITEM	DESCRIPTION	ITEM	DESCRIPTION
1	Vapor line	4	Pipe sleeve
2	Insulation material	5	Insulation material
3	Liquid line	6	Min. 18-gauge power/communication cable

To bundle piping and cables:

1. Be sure to wrap each pipe with proper insulation material.
2. Secure the piping by wrapping vinyl tape around the pipe.
 - Use narrow-size tape for wrapping the actual pipe, Figure 7.16 on the facing page.
3. You can include the drain hose in the bundled piping and wrap all of them together using wider vinyl tape, Figure 7.16 on the facing page.
 - The end of the drain-hose outlet must be routed above the ground.

Figure 7.16 Bundling and taping piping and cables

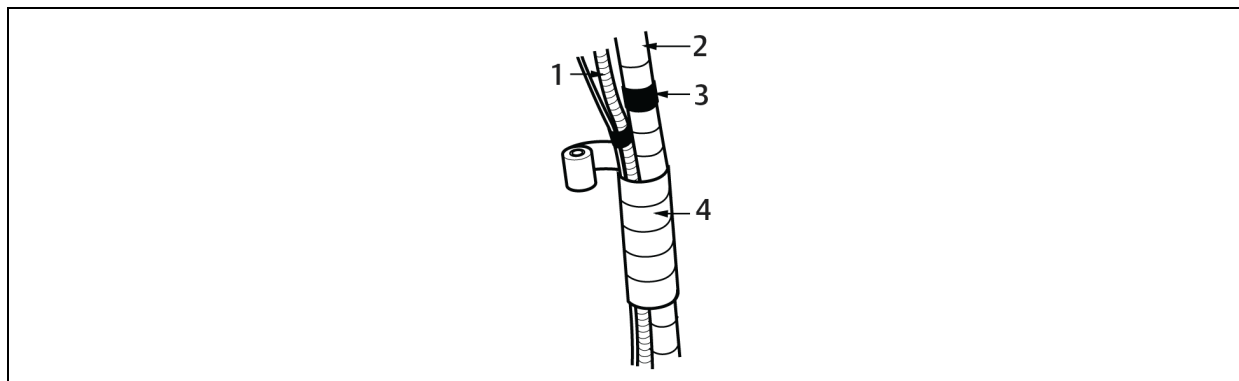

ITEM	DESCRIPTION	ITEM	DESCRIPTION
1	Drain hose	3	Vinyl tape (narrow)
2	Pipe	4	Wrap with vinyl tape (wide)

Bundling and Trap when Indoor Unit is above Outdoor Unit

1. Refer to Figure 7.17 below, and tape the piping, drain hose, and connection cable from down to up.
2. Secure the taped piping along the exterior wall using pipe clamps.
3. Create a trap above the electrical connections cover to prevent water from penetrating electrical components and wiring.

Figure 7.17 Piping/Trap when indoor unit is above outdoor unit

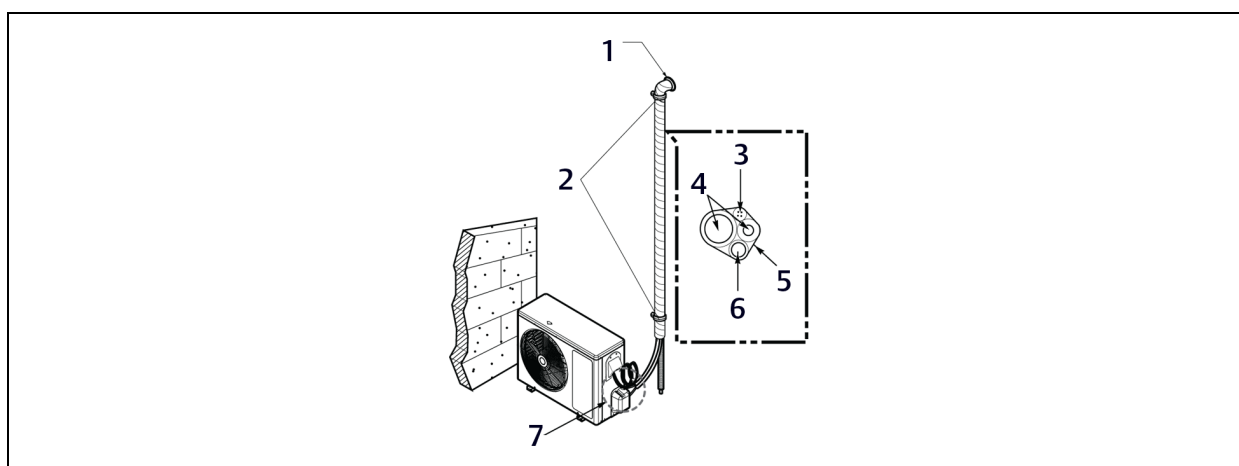

ITEM	DESCRIPTION	ITEM	DESCRIPTION
1	Seal small openings around piping with a gum-type sealant.	5	Taping
2	Pipe clamps to secure pipes against wall.	6	Drain hose
3	Connection cable	7	Trap is required to prevent water from entering electrical parts.
4	Piping		

Bundling and Trap when Indoor Unit is below Outdoor Unit

1. Refer to Figure 7.18 below, and tape and bundle the piping, drain hose, and connection cable from down to up.
2. Secure the taped piping along the exterior wall using pipe clamps.
3. Create a trap above the electrical connections cover to prevent water from penetrating electrical components and wiring.

Figure 7.18 Piping/Trap when indoor unit is below outdoor unit

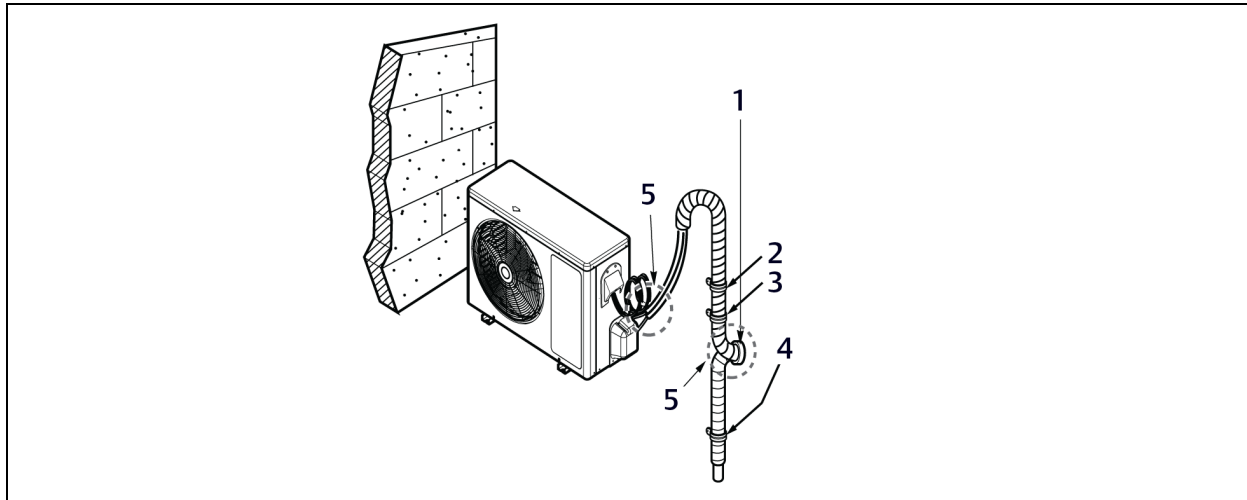

ITEM	DESCRIPTION	ITEM	DESCRIPTION
1	Seal any small openings around the piping with gum-type sealant.	4	Pipe clamp
2	Pipe clamp	5	Trap
3	Pipe clamp		

7.4.3 Routing the Drain Hose for Indoor Unit

Drain hose is routed from the indoor unit, through the structure (wall) to the outdoors. The hose should slope at an angle where it is higher at the indoor unit and lower at the outdoor area, letting gravity push condensation down and out. Figure 7.19 on the facing page, shows the proper drainage slope. Figure 7.20 on the facing page, shows incorrect methods of routing the drain hose, which cause leakage at the indoor unit.

Figure 7.19 Correct slope angle for drain hose

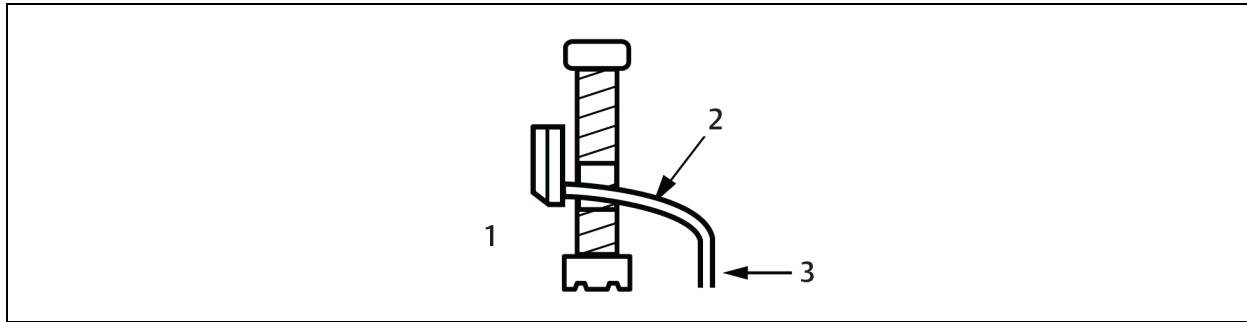

ITEM	DESCRIPTION
1	Indoor unit
2	Downward slope to outdoor for proper drainage
3	Piping

Figure 7.20 Incorrect methods of routing drain hose

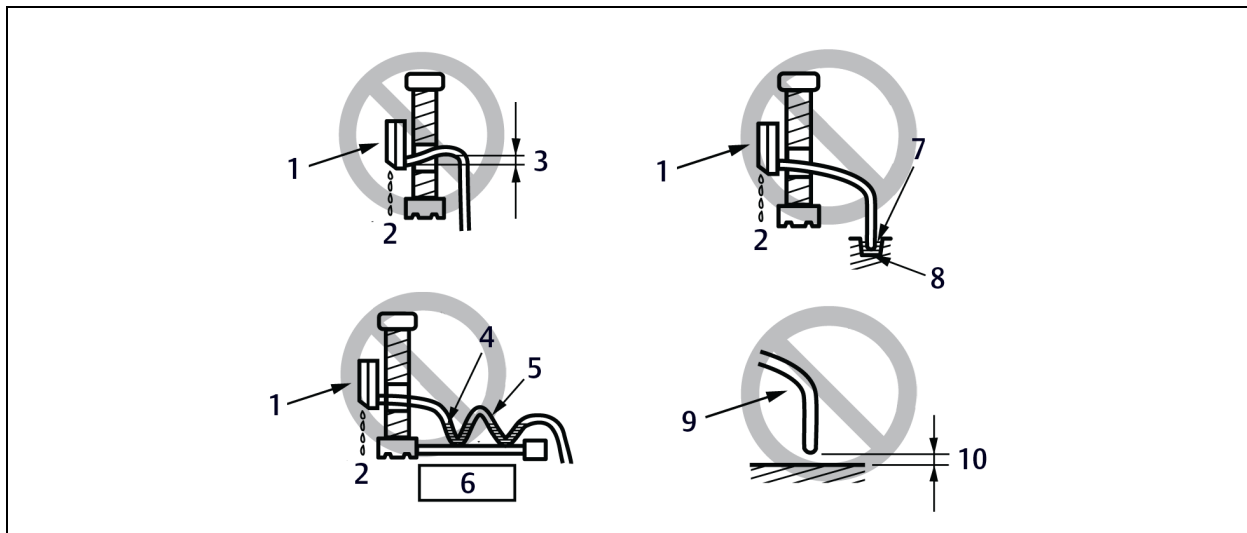

ITEM	DESCRIPTION	ITEM	DESCRIPTION
1	Indoor unit	6	Waving
2	Water leakage	7	Tip of drain hose dipped in water
3	Upward slope to outdoor can cause indoor leaks.	8	Ditch
4	Accumulated drain water	9	Drain hose
5	Air	10	Less than 2-in. gap from ground.

7.4.4 Installing a Drain Hose on the Outdoor Unit

Depending on the installation site, it may be necessary to install a drain plug (factory-supplied).

1. Depending on your unit model, refer to Figure 7.21 below. or Figure 7.22 on the facing page. and to Table 7.12 below, for the drain-connection components.
2. Connect a field-supplied hose to the drain connections (A). If the hose is too long, position it carefully to prevent kinks.

Table 7.12 Outdoor unit drain-connection components

LABEL	QUANTITY, EACH		COMPONENT
	SRC18	SRC24, SRC36	
1	1	1	Drain connection
2	3	1	Drain cap
3	1	1	Drain washer

NOTE: Do not use a drain hose with the outdoor unit in cold climates, otherwise the drain water may freeze and impair heating performance.

Figure 7.21 Outdoor unit drain-connection components for SRC18

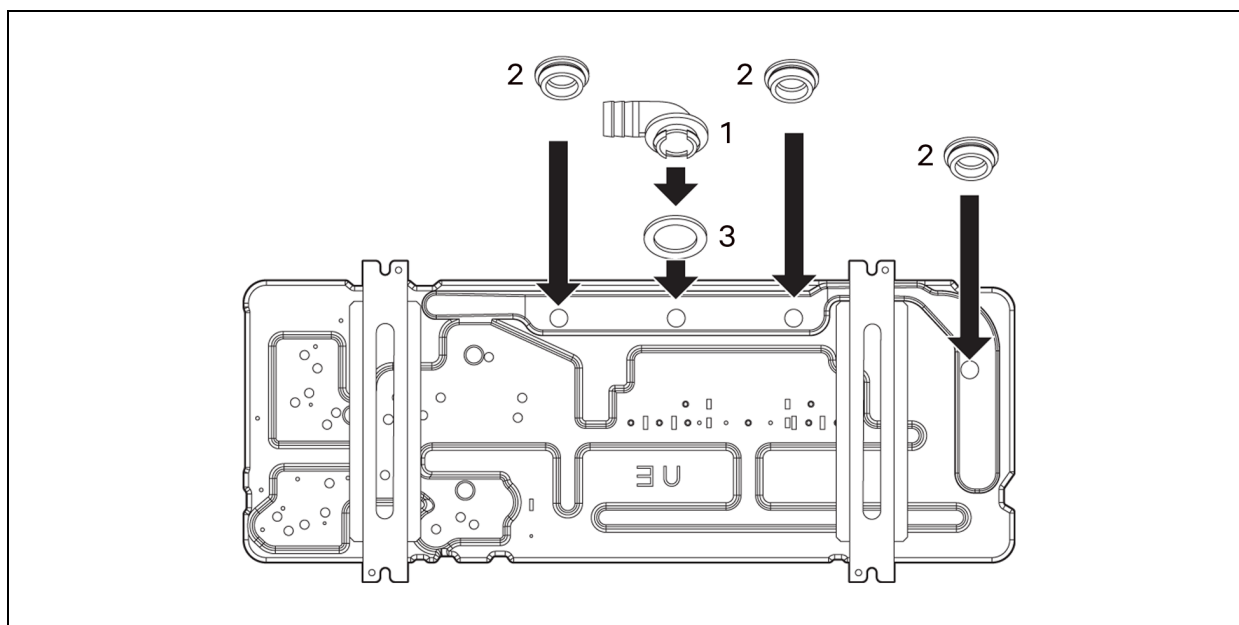
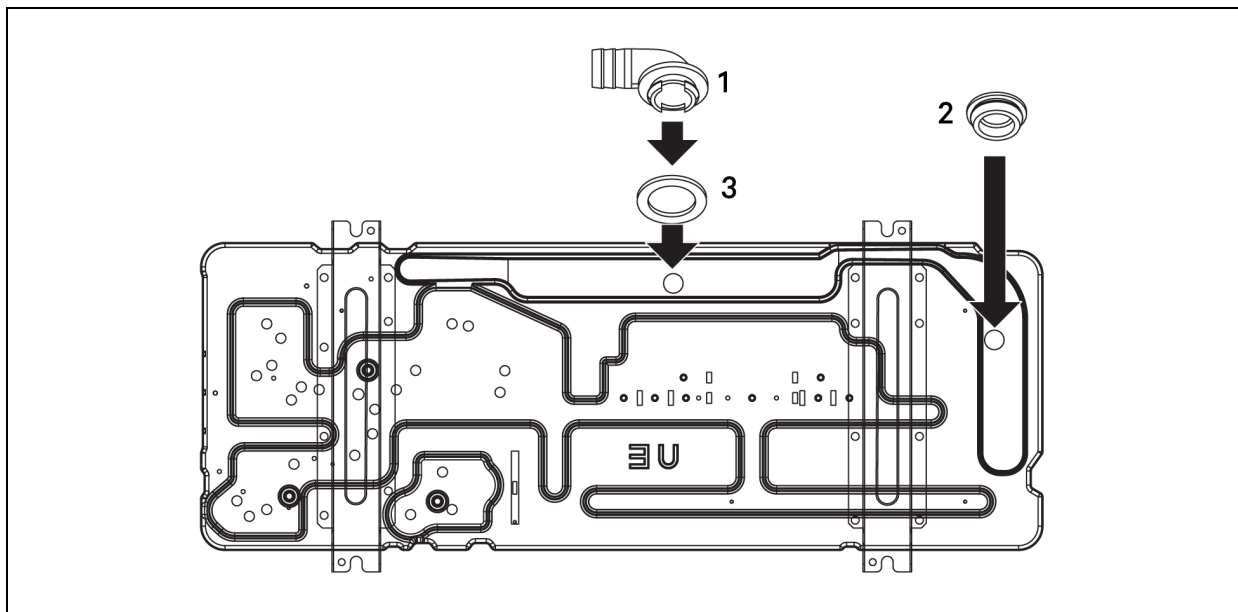

Figure 7.22 Outdoor unit drain-connection components for SRC24 and SRC36



7.4.5 Connecting Piping on the Outdoor Unit

1. Remove the tubing cover by loosening the fastening screws, Figure 7.23 below.

NOTE: When tightening the flare nut with a torque wrench, make sure the direction for tightening follows the arrow on the wrench.

Figure 7.23 Removing connection cover from outdoor unit

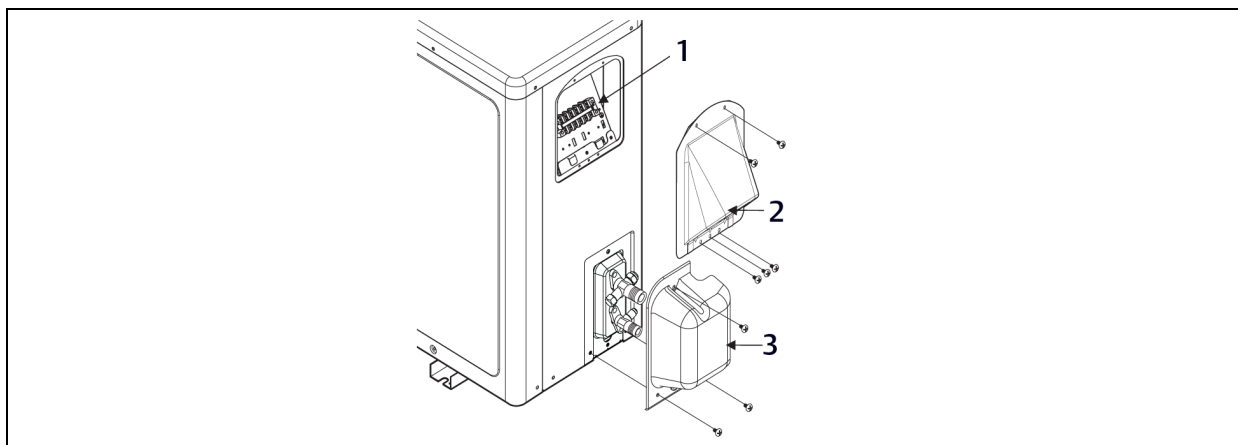

ITEM	DESCRIPTION
1	Terminal block
2	Terminal-block cover
3	Tubing cover

2. Align the center of the refrigerant pipe and corresponding connection as shown in Figure 7.24 below.

Figure 7.24 Align center of piping connection

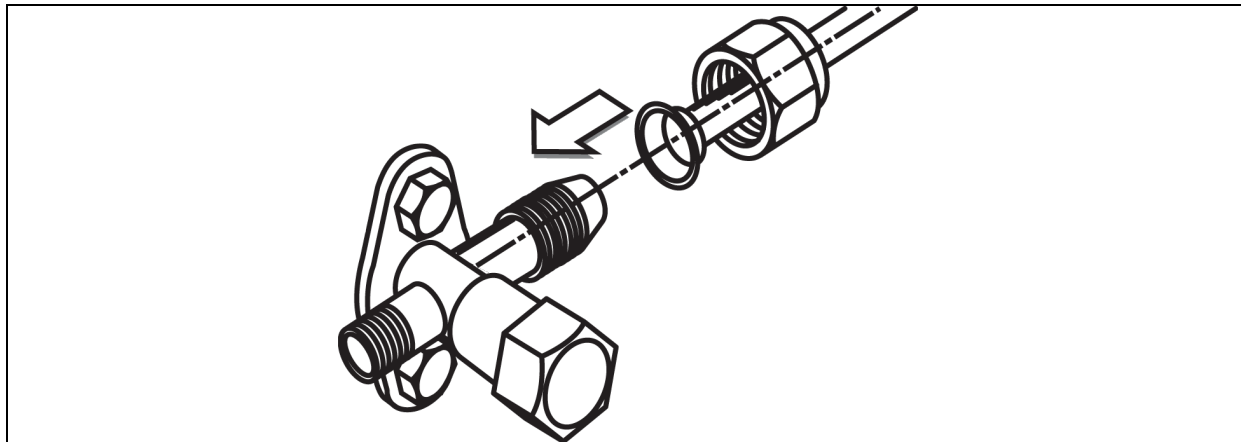

3. Refer to Figure 7.25 on the facing page, for correct liquid and gas pipe attachment to the outdoor unit.
4. Place a couple of drops of refrigerant oil on the opening rim of the flare before assembling, making sure that you do not introduce any contaminants, and tighten the flare nut by hand.
5. Following the torque guidelines in Table 7.13 below, finish tightening the flare nut with a torque wrench until the wrench clicks referring to Figure 7.25 on the facing page, for correct connection points.

NOTE: When tightening the flare nut with a torque wrench, make sure the direction for tightening follows the arrow on the wrench.

Table 7.13 Tightening torque for flare nuts

PIPE SIZE (IN. O.D.)	TIGHTENING TORQUE (FT-LBS)
1/4	13.9 - 18
3/8	24.5 - 30.3
1/2	39.7 - 47.7
5/8	45.5 - 59.2
3/4	71.6 - 87.5

Figure 7.25 Correct piping attachment for outdoor unit

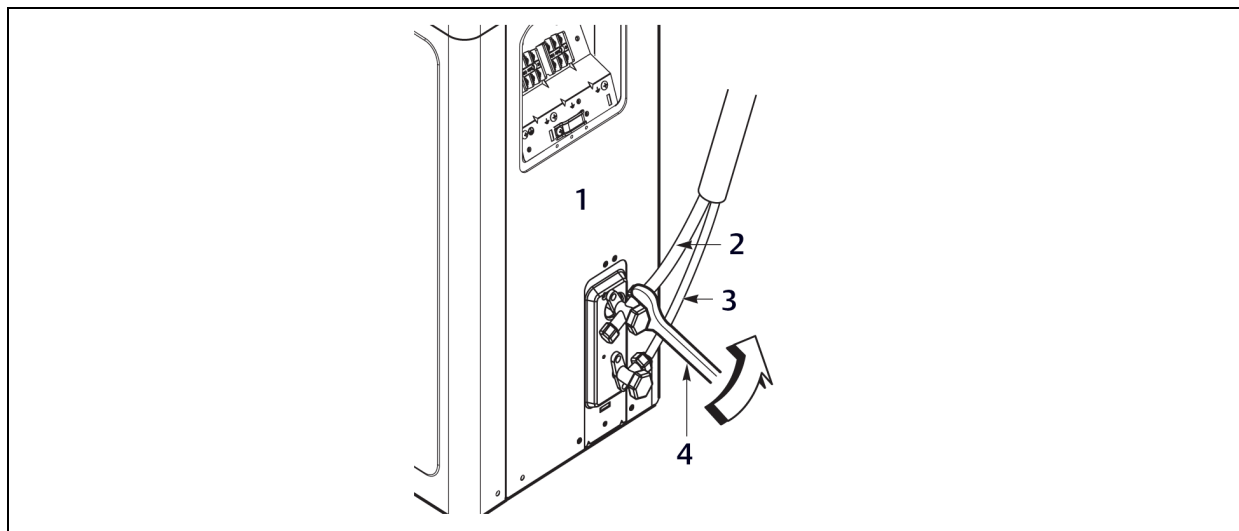

ITEM	DESCRIPTION	ITEM	DESCRIPTION
1	Outdoor unit	3	Liquid side piping (smaller diameter)
2	Gas side piping (larger diameter)	4	Torque wrench

7.4.6 Connecting Piping on the Indoor Unit

While following this procedure, refer to [Pipe Bundling](#) on page 68 for specific bundling instructions, and to [Routing the Drain Hose for Indoor Unit](#) on page 70 for proper drainage slope during piping.

1. Pull the screw cap at the bottom of the indoor unit.
2. Unscrew the 3 screws at the bottom of the chassis cover, Figure 7.26 on the next page, and remove the chassis cover, taking care not to scratch the main horizontal vane.

Figure 7.26 Removing the chassis cover from indoor unit

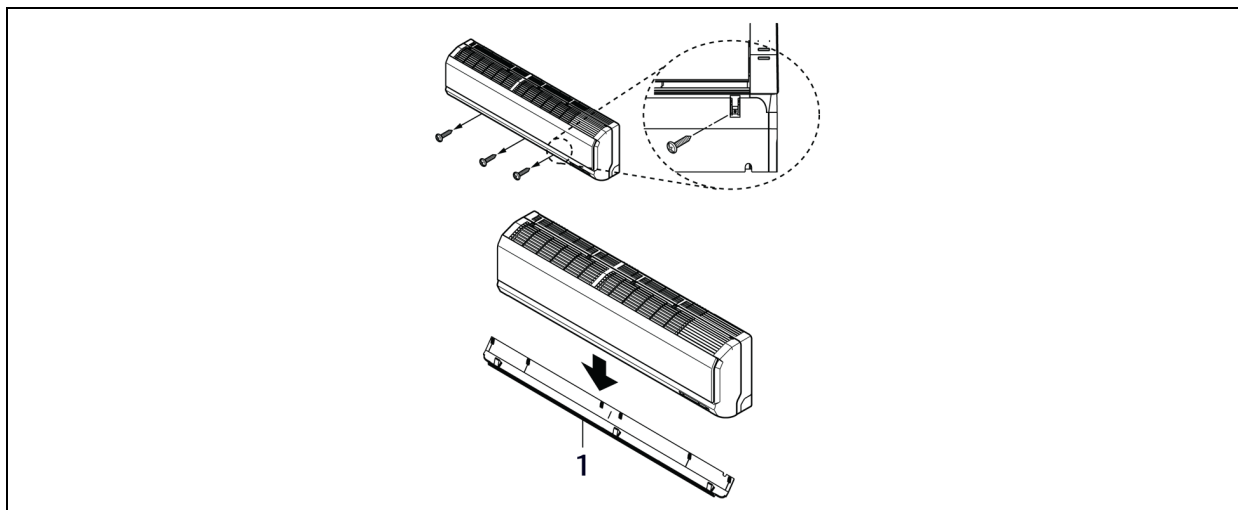

ITEM	DESCRIPTION
1	Chassis cover

3. From the rear of the indoor unit, pull the tubing holder away from the unit as shown in Figure 7.27 below.
4. Remove the pipe port cover.
5. Position the tubing by unfolding the tubing and bending the tubing slowly downward first, as shown in Figure 7.27 below.

NOTE: Bending the tubing directly left or right, without bending downward first, may cause damage.

Figure 7.27 Bending drain tubing at rear of indoor unit

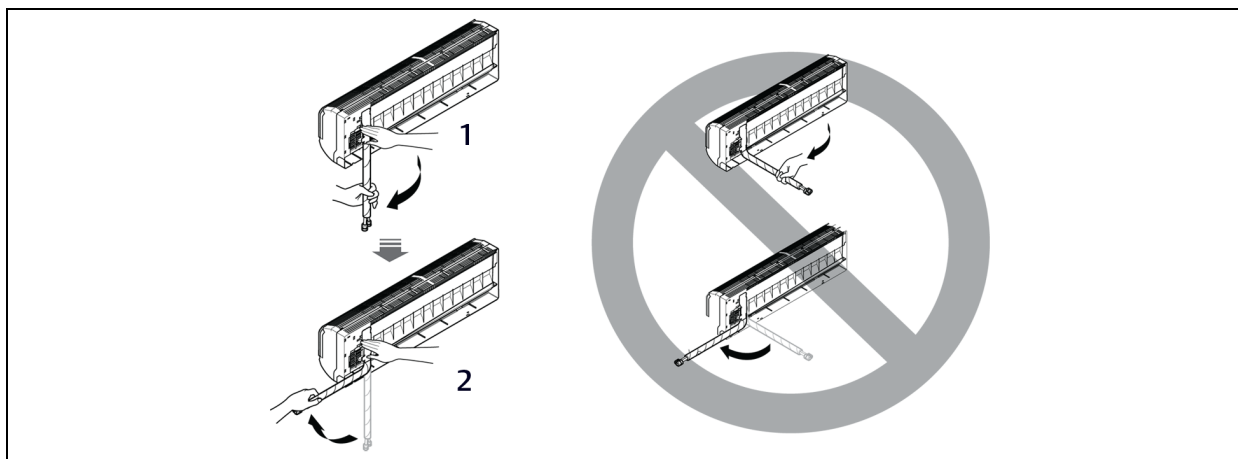

ITEM	DESCRIPTION
1	Unfold slowly downward
2	Bend from downward position

- As shown in Figure 7.28 below, the fully encase the connection pipe and the indoor-unit pipe in insulation material by binding them together using vinyl tape. Make sure there are not gaps when binding.

Figure 7.28 Piping connection with insulation material

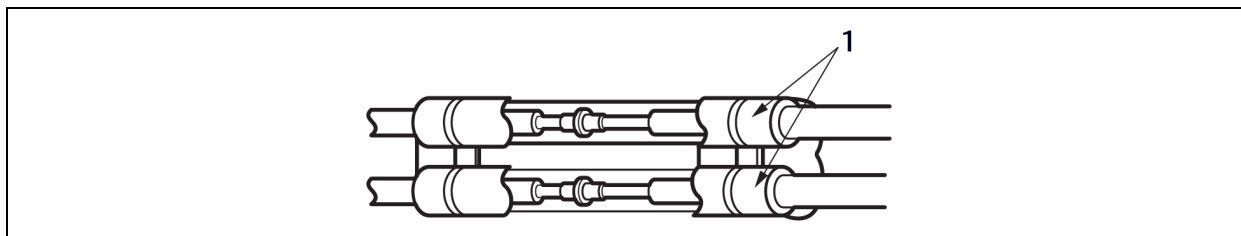

ITEM	DESCRIPTION
1	Insulation material

- Make sure the tube cutting line is placed upward, Figure 7.29 below.

Figure 7.29 Correct cutting line placement

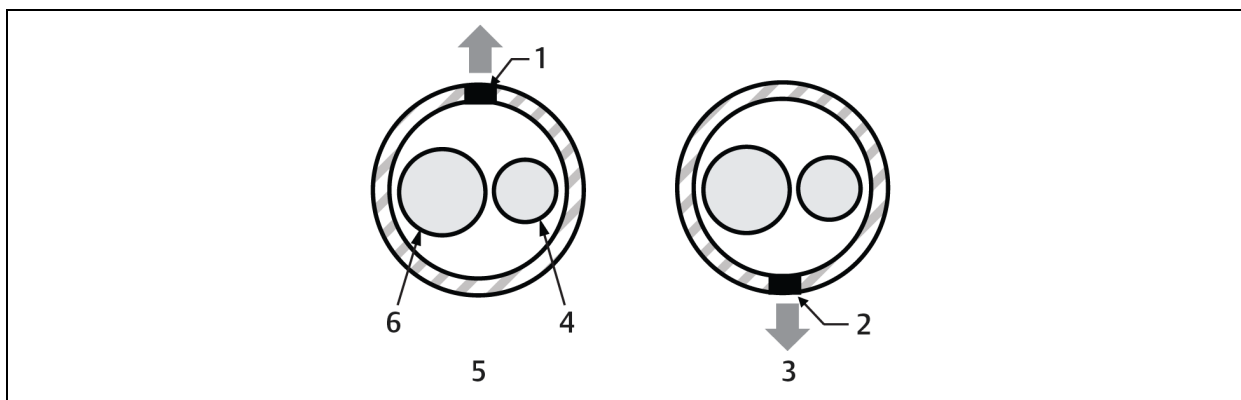

ITEM	DESCRIPTION	ITEM	DESCRIPTION
1	Cutting line	4	Liquid pipe
2	Cutting line	5	Correct
3	Incorrect	6	Gas pipe

8. Use narrow type vinyl tape, and make sure that the section placed in the rear pipe housing is wrapped sufficiently.
9. Continue to wrap the indoor-unit pipe connection to the outdoor-unit as shown in Figure 7.30 below.

Figure 7.30 Wrapping connection pipe to indoor-unit pipe

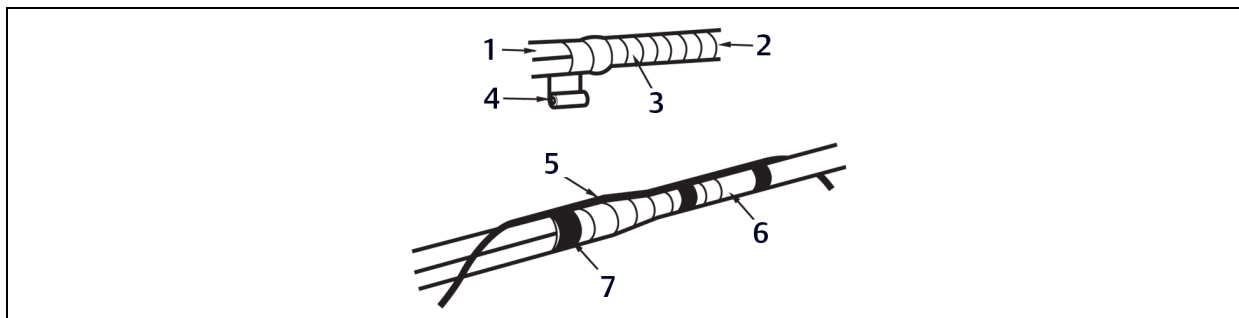

ITEM	DESCRIPTION	ITEM	DESCRIPTION
1	Connection pipe	5	Connection cable
2	Indoor-unit pipe	6	Pipe
3	Wrap with vinyl tape	7	Vinyl tape (narrow)
4	Vinyl tape (wide)		

10. Using a wider vinyl tape, bundle the piping and the drain hose together, Figure 7.31 below.
 - The tape should cover the piping and fit into the rear pipe housing on the back of the indoor unit as shown in Figure 7.32 on the facing page.

Figure 7.31 Bundling pipe and drain hose at rear of indoor unit

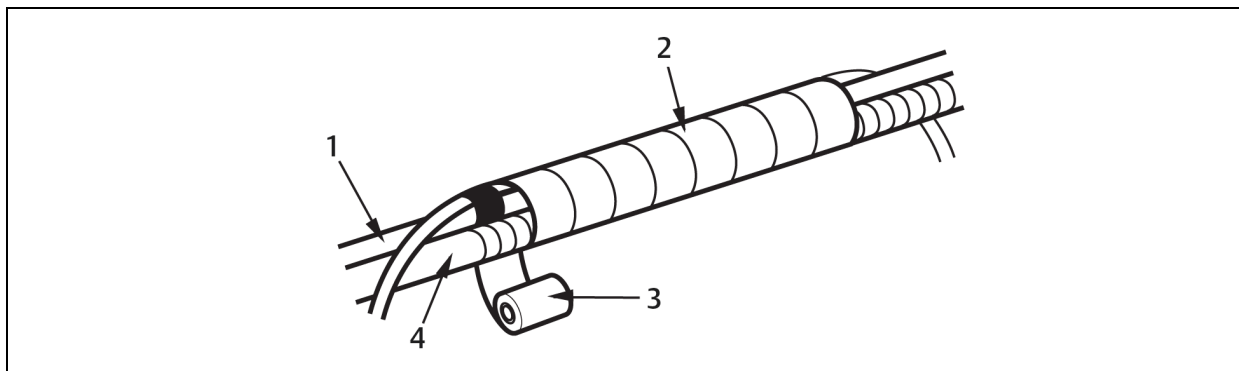

ITEM	DESCRIPTION	ITEM	DESCRIPTION
1	Pipe	3	Vinyl tape (wide)
2	Wrap with vinyl tape.	4	Drain hose

Figure 7.32 Piping bundle placement in housing at rear of indoor unit

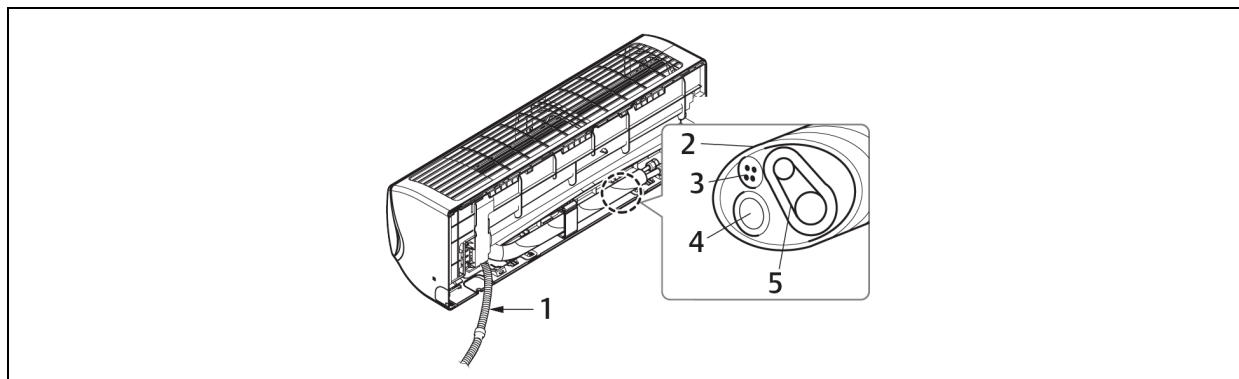

ITEM	DESCRIPTION	ITEM	DESCRIPTION
1	Drain hose	4	Drain hose
2	Tape	5	Connecting pipe
3	Connecting cable		

7.5 Insulating Refrigeration Piping

To prevent heat loss/heat gain through the refrigerant piping, all refrigerant piping, including liquid lines and vapor lines, must be insulated separately. Insulation must be a minimum 1/2-in. thick, and the thickness may need to be increased based on ambient conditions and local codes. All refrigerant piping, including field-supplied isolation ball valves, service valves, and elbows must be completely insulated using closed-cell pipe insulation. All insulation joints must be glued with no air gaps. Insulation material must fit snugly against the refrigerations pipe with now space between it and the pipe. Insulation passing through pipe hangers, inside conduit, and/or sleeves must not be compressed. Protect insulation inside hangers and supports with a second layer. All pipe insulation exposed to direct sunlight and deterioration-producing elements must be properly protected with a PVC-aluminum vapor-barrier jacket, or placed in a weather-resistant enclosure such as a pipe rack with a top cover. The design engineer should perform calculations to determine if the factory-supplied insulation jackets have sufficient thickness to meet local codes and to void sweating at job-site conditions. Maximum refrigerant-pipe temperature is 227°F. Minimum refrigerant-pipe temperature is -4°F. Add additional insulation if necessary.

NOTE: Do not insulate gas and liquid pipes together as this can result in pipe leakage and malfunction due to extreme temperature fluctuations. Be sure to fully insulate the piping connections.

Figure 7.33 Typical pipe-insulation, power wire, and communications-cable arrangement

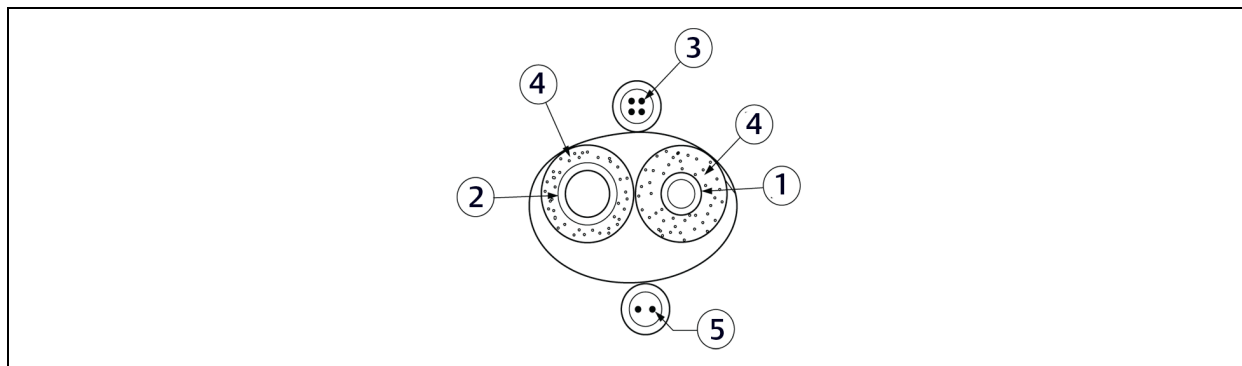

ITEM	DESCRIPTION	ITEM	DESCRIPTION
1	Liquid pipe	4	Insulation
2	Gas pipe	5	Communication cable
3	Power wiring		

Figure 7.34 Typical butt-joint insulation at indoor unit

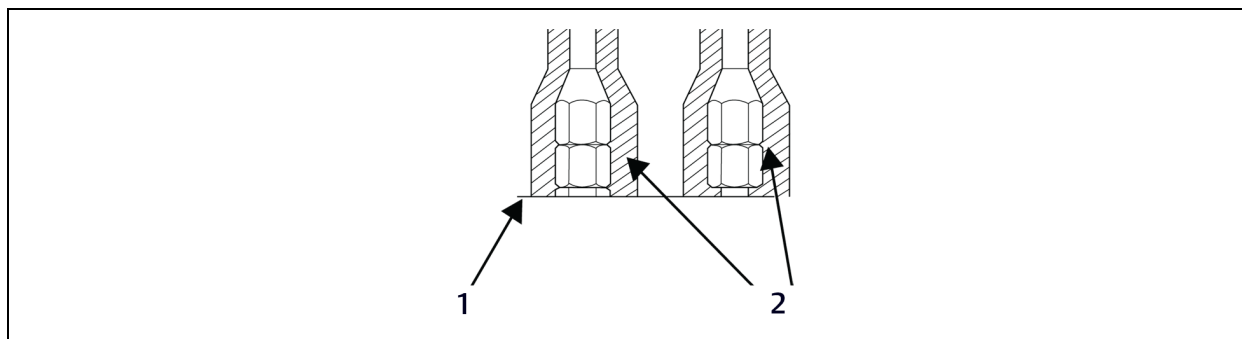

ITEM	DESCRIPTION
1	Surface of indoor-unit casing
2	Field-supplied pipe insulation

Figure 7.35 Typical refrigerant flare-fitting insulation

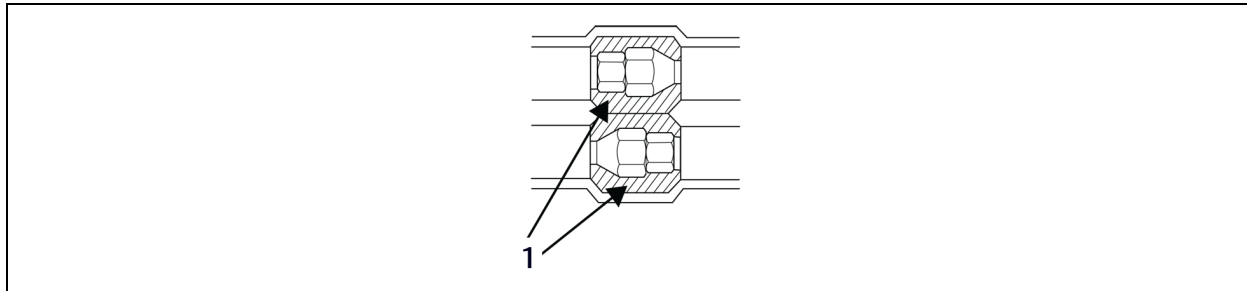

ITEM	DESCRIPTION
1	Field-supplied insulation

7.5.1 Minimum Requirements for Wall Thickness of Ethylene Propylene Diene Methylene (EPDM) Pipe Insulation

NOTE: Follow local codes when selecting EPDM insulation wall thickness.

Table 7.14 Insulation guidelines for typical and special circumstances

CLASSIFICATION		AIR-CONDITIONED LOCATION		NON-AIR-CONDITIONED LOCATION	
		1. TYPICAL LOCATION	2. SPECIAL LOCATION	3. TYPICAL LOCATION	4. SPECIAL LOCATION
Liquid pipe	1/4 in.	1/2 in.	1/2 in.	1/2 in.	1/2 in.
	3/8 in.				
	≥ 1/2 in.				
Vapor	3/8 in.	1/2 in.	3/4 in.	3/4 in.	1 in.
	1/2 in.				
	5/8 in.				
	3/4 in.				
	7/8 in.				
	1 in.	3/4 in.	1 in.	1 in.	
	1-1/8 in.				
	1-1/4 in.				
	1-3/8 in.				
	1-1/2 in.				
1-3/4 in.					

The classification descriptions are:

1. Typical location (air-conditioned): When the piping passes through an indoor area where the indoor unit operates.
 - Apartment, classroom, office, mall, hospital, etc.
2. Special location (air-conditioned):
 - a. When the location is air-conditioned, but there is severe temperature/humidity difference due to high ceilings.
Church, auditorium, theater, lobby, etc.
 - b. When the location is air-conditioned, but internal temperature/humidity are high.
Bathroom, swimming pool, locker room, etc.
3. Typical location (non air-conditioned): When the piping passes through an indoor area where the indoor unit does not operate.
 - Hallway, dormitory, school, etc.
4. Special location (non air-conditioned): If the following conditions are present:
 - a. When the piping passes through an indoor area where the indoor unit does not operate.
 - b. When the humidity is high and there is no air flow in the location where the piping is installed.

The thickness of the above insulation material is based on heat conductivity of 0.61 Btu/in/h/ft²/°F.

7.6 Air Purging

Air purging is performed after all piping is connected between the indoor and the outdoor unit. This step is necessary to be sure that air refrigerant can flow through the system without the danger of leakage or pressure issues. Air and moisture that is left in the piping can lead to undesirable results and can cause damage to the working unit. It is important to go through a complete air-purging cycle to be sure that the lines are cleared out. Note that you may have to repeat this process if any air or moisture is found to remain in the piping. After air purging and evacuating the lines, be sure to do a leak test for all piping and tubing.

Insufficient or incorrectly-performed air purging may lead to the following:

- Pressure in the system can rise.
- Operating current can rise.
- Cooling or heating efficiency falls.
- Moisture in the refrigerant circuit may freeze and block capillary tubing.
- Water can lead to corrosion of parts in the system.

To purge the air from the system:

1. Verify that each set of pipes (liquid and gas) are properly connected between the indoor and outdoor unit.
2. Verify that all wiring for a test run is complete.
3. Remove the service-valve caps from the gas and liquid valves at the outdoor unit, Figure 7.36 on the facing page.
 - Keep both liquid and gas service valves closed at this step.

Figure 7.36 Removing service-valve caps from outdoor unit for purging

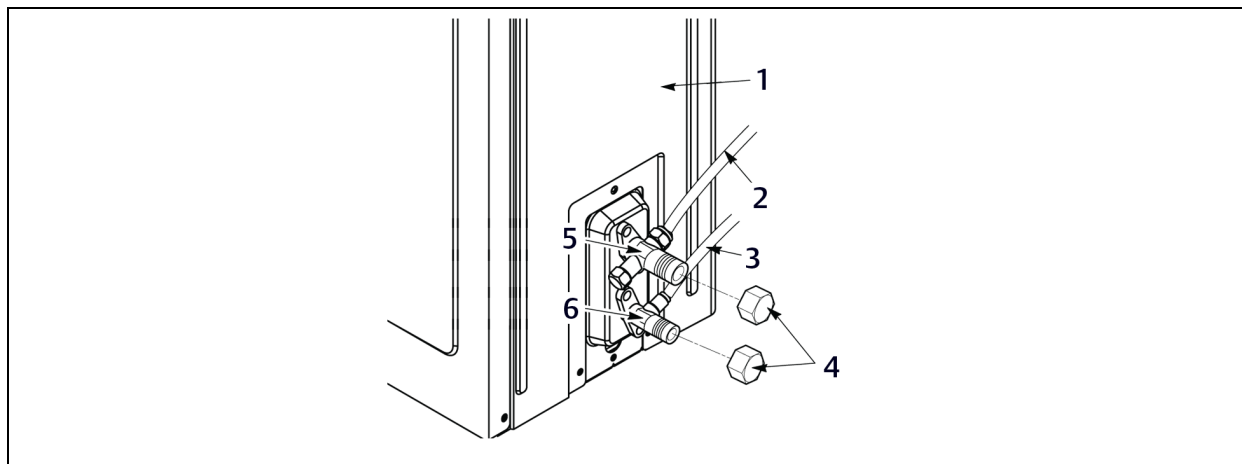

ITEM	DESCRIPTION	ITEM	DESCRIPTION
1	Outdoor unit	4	Valve caps
2	Gas side	5	3-way valve (close)
3	Liquid side	6	2-way valve (close)

4. Set-up the purging-hose connections, Figure 7.37 below.

Figure 7.37 Evacuation set up

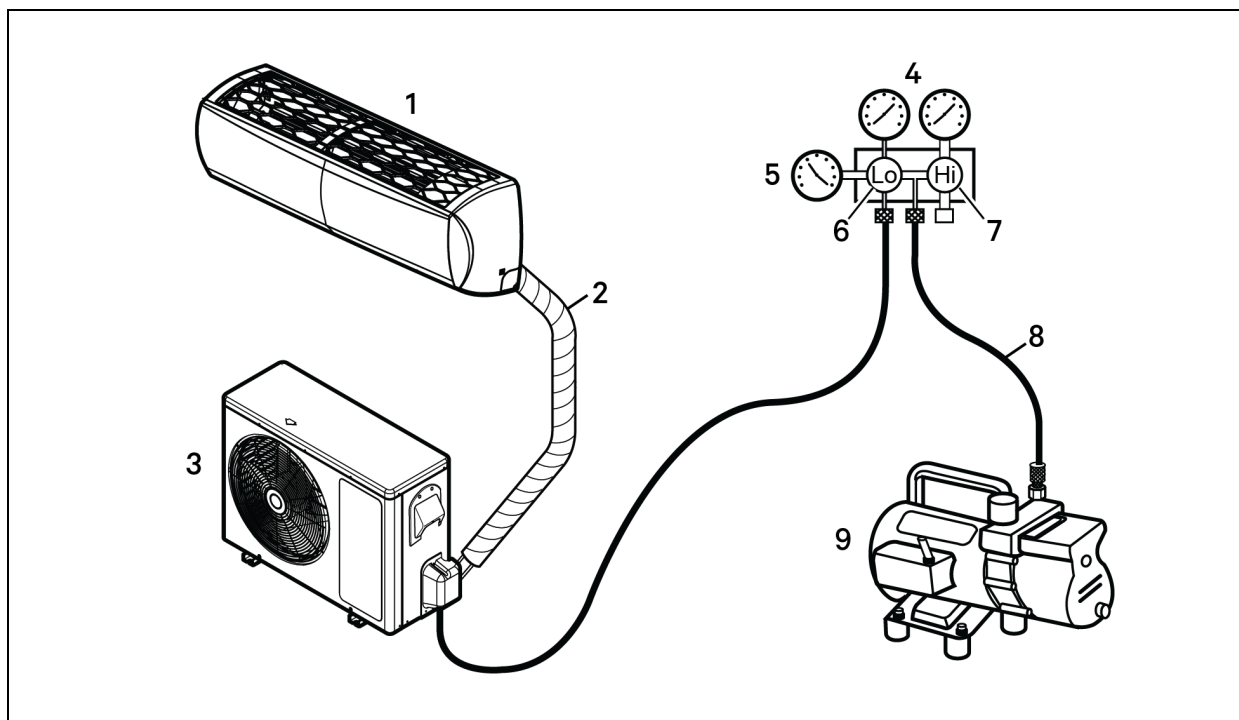

ITEM	DESCRIPTION	ITEM	DESCRIPTION
1	Indoor unit	6	Lo = open
2	Piping bundle	7	Hi = close
3	Outdoor unit	8	Charge hose
4	Manifold valve	9	Vacuum pump
5	Pressure gauge		

5. Do a leak test per [Piping Leak Test](#) below.
 - A successful leak test must be completed before beginning evacuation.
6. Refer to [Evacuation](#) on page 86 to complete the purge process.

7.6.1 Piping Leak Test

Perform the leak test by pressurizing nitrogen gas to 550 psi on both the liquid and gas pipes. Test with the piping service valves closed. If the pressure does not drop for 24 hours, the system passes the test. If the pressure drops, there is a nitrogen leak in the system. Find the leak, repair it, and test again.



WARNING! Risk of using combustible gases. Can cause explosion and fire resulting in building and equipment damage, serious injury or death. Do not use combustible gases, including oxygen for leak detection. Use only inert gas (nitrogen) when checking plumbing leaks, cleaning or repairing pipes, etc.

Connecting the Pressure Gauge

NOTE: To avoid nitrogen entering the refrigerant system in a liquid state, the top of the cylinder must be higher than its bottom when you pressurize the system. Be sure the cylinder is used in a vertical standing position.

1. Connect the manifold valve (which includes the pressure gauges) and the dry-nitrogen gas cylinder to the services valves using a charge hose, Figure 7.38 below.
2. Pressurize the system to maximum 550 psig with dry-nitrogen gas and close the cylinder valve when the gauge reaches 550 psig.

Figure 7.38 Leak-test set-up diagram

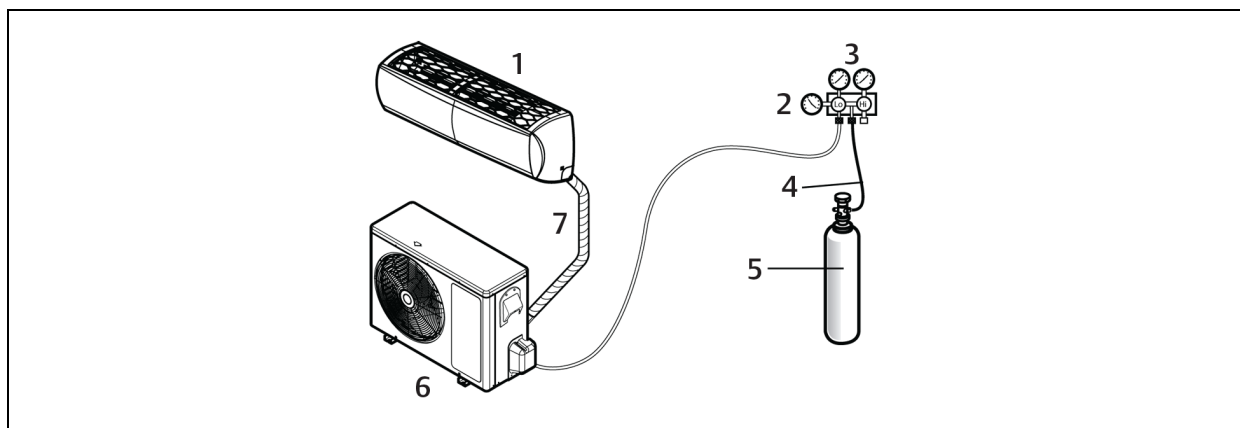

ITEM	DESCRIPTION	ITEM	DESCRIPTION
1	Indoor unit	5	Nitrogen-gas tank (upright position)
2	Pressure gauge	6	Outdoor unit
3	Manifold valve	7	Piping bundle
4	Charge hose		

Soap-and-Water Leak Testing

1. Remove the caps from the 2-way and 3-way valves, Figure 7.36 on page 83.
2. Open the 2-way valve by turning the valve stem counter-clockwise approximately 90 degrees, wait for 2 to 3 seconds, and close it.
3. While running nitrogen pressure, apply a soapy-water or liquid, neutral detergent on the indoor or outdoor unit connections using a soft brush, and observe the connections for any leaks.
 - Bubbles at connection points or joints indicate a leak.
4. Make a note of any leaks along the liquid and gas piping.
5. Disengage the nitrogen pressure by loosening the charge hose at the cylinder, Figure 7.38 above.
6. When pressure returns to normal, disconnect the charge hose from the cylinder.
7. Make repairs to all connections and piping where leaks were observed.

8. When repairs are complete, repeat the leak test using nitrogen pressure and check for further leaks.
9. Once the piping system is leak-free, proceed to [Evacuation](#) below.

Ambient Temperature for the Leak Test

If the ambient temperature changed between the time when the pressure was applied and when the pressure-drop was checked, adjust the results by factoring-in approximately 1.45 psi for each 2°F of temperature difference.

Correction formula = (Ambient temperature when pressure was applied – Ambient temperature when pressure drop was checked) x 0.01.

For example:

When pressure (550 psig) was applied, the ambient temperature was 80.6°F. When the pressure drop was checked 24 hours later (540 psi), the ambient temperature was 68°F.

Therefore, $80.6 - 68 \times 0.01 = 0.126$. In this case, the pressure drop of 0.126 was due to temperature difference, and there is no leak in the refrigerant-piping system.

7.6.2 Evacuation

After successfully completing leak testing, use the same hook-up described in [Evacuation set up](#) on page 84, to perform the evacuation procedure.

NOTE: Be sure to use a manifold valve for air purging. If it is not available, use a stop valve. Be sure that the knob of the 3-way valve is always kept closed.

To evacuate the system:

1. Confirm that the “Lo” knob of the manifold valve is open, see Figure 7.37 on page 84.
2. Confirm that the “Hi” knob of the manifold valve is closed.
3. Run the vacuum pump until the system is evacuated down to 300 microns, and continue to run the pump an additional 15 minutes.

NOTE: The duration of running the vacuum pump will vary according to pipe length and pump capacity. Refer to Table 7.15 below for accurate time duration.

Table 7.15 Evacuation timing*

TUBING LESS THAN 33 FT.	TUBING MORE THAN 33 FT.
10 minutes or more	15 minutes or more
* Required time for evacuation when 30-gal/h vacuum pump is used.	

4. When appropriate time has elapsed, turn-off the pump and leave the connections secured on the service valves for 5 minutes.
5. If the system fails to hold 500 microns or less, check all connections for a tight fit and repeat the evacuation steps.
6. When the correct vacuum is reached, close the “Lo” knob of the manifold valve and stop the vacuum pump.

7.6.3 Removing Purge and Test Equipment

When evacuation is completed, turn-off all valves at the outdoor unit and safely disengage the manifold valve and vacuum pump using the following steps.

1. Using a wrench, turn the valve of the liquid stem counter-clockwise to fully open the valve, see [Evacuation set up](#) on page 84.
2. Turn the valve of the gas temp counter-clockwise to fully open the valve.
3. Loosen the charge hose connected to the gas-side service port slightly to release the pressure, and remove the hose.
4. Replace the flare nut and its cap on the gas service port, and fasten the flare nut securely using an adjustable wrench.
 - This step is very important to prevent leakage from the system.
5. Replace the valve caps at both gas- and liquid-side service valves and fasten them tightly.

This page intentionally left blank.

8 ELECTRICAL CONNECTIONS



WARNING! Arc flash and electric shock hazard. Open all local and remote electric power-supply disconnect switches, verify with a voltmeter that power is Off and wear personal protective equipment (PPE) per NFPA 70E before working within the electric control enclosure. Failure to comply can cause serious injury or death. Customer must provide earth ground to unit, per NEC, CEC and local codes, as applicable. Before proceeding with installation, read all instructions, verify that all the parts are included and check the nameplate to be sure the voltage matches available utility power. The Liebert controller does not isolate power from the unit, even in the “Unit Off” mode. Some internal components require and receive power even during the “Unit Off” mode of the controller. The only way to ensure that there is NO voltage inside the unit is to install and open a remote disconnect switch. Refer to unit electrical schematic. Follow all local codes.

Do not connect ground wire to refrigerant, gas or water piping, to lightning rods, to telephone ground wiring, or to the building plumbing system.

Replace and securely fasten all control box and panel covers immediately after working on the unit to protect the operator from the hazards noted.

NOTICE

Risk of electrical phase reversal. Can cause equipment damage, unit malfunction and loss of cooling operation.

If there is a possibility of reversed phase, phase loss, momentary blackout, or the power goes on and off while the system is operating, install a field-supplied phase-loss protection circuit.

NOTE: Consider ambient conditions (temperature, direct sunlight, inclement weather, etc.) when selecting, installing, and connecting the power wiring.

8.1 Power-supply and Power-wiring Specifications

- Liebert SRC systems operate at 1Ø, 208 – 230 V, 60 Hz.
- Power-supply wire type and size should be selected based on National Electrical Code and local codes. Maximum allowable voltage fluctuation $\pm 10\%$ or nameplate rated value. Refer to Figure 8.1 on the next page for wiring guidelines.
- Properly ground the indoor and outdoor unit per National Electrical Code and local codes.
- Use only copper wiring that is stranded and shielded with the wires separately insulated.
- Ground wire should be longer than the common power/communication wires.
- Refer to the appropriate circuit and terminal-block diagrams for your model unit.
- Always match color codes of each wire and follow wiring diagram.

Figure 8.1 Indoor and Outdoor wiring and communications cable diagram

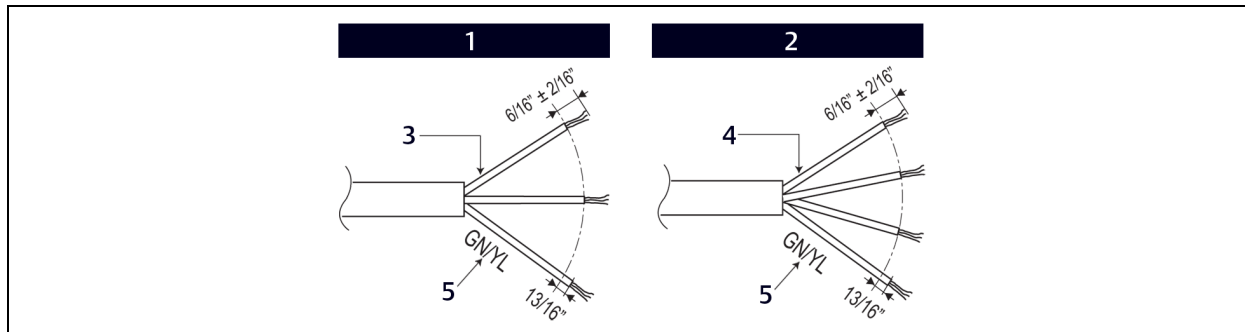

ITEM	DESCRIPTION	ITEM	DESCRIPTION
1	Power wiring, ground to outdoor unit	4	For 9/12/18K indoor units: AWG 18
2	Power wiring, ground, communication cable from outdoor unit to indoor unit	5	GN/YL = Ground, Yellow
3	For 9/12K indoor units: AWG 14 For 18K indoor units: AWG 12		

Best practice dictates using ring or spade terminals to terminate power wiring at the power terminal block, Figure 8.2 below.

Figure 8.2 Typical ring terminal

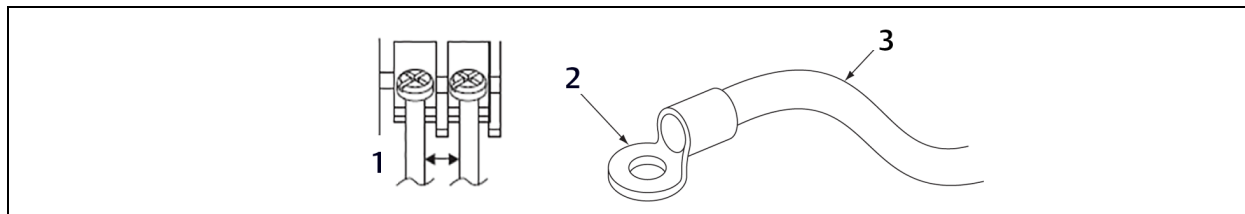

ITEM	DESCRIPTION
1	More than 5 mm
2	Ring terminal
3	Power wiring

! WARNING! Risk of improper electrical connection termination. Can cause building and equipment damage, excessive heat at the terminations, smoke, fire, electric shock, serious injury and death. Do not terminate different gauge wires to the power terminal block. Slack in the wiring may generate heat and fire. Do not ground the shield of the communications cable to the indoor unit frame or other grounded entities of the building.

If ring terminals or space clips are not available then:

- When terminating wires of the same thickness, follow the instructions in Figure 8.3 below.
- Attach the wire securely without placing external force on the terminal block.
- Use an appropriately-sized screwdriver to tighten the terminals.
- Do not over-tighten the connections. Over-tightening may damage the terminals.
- Never apply line-voltage power to the communications-cable terminal block. If contact is made, the PCBs may be damaged.
- Always include some allowance in the wiring length when terminating. Provide some slack to facilitate removal of electrical panels when servicing.

Figure 8.3 Proper and Improper power-wiring connections

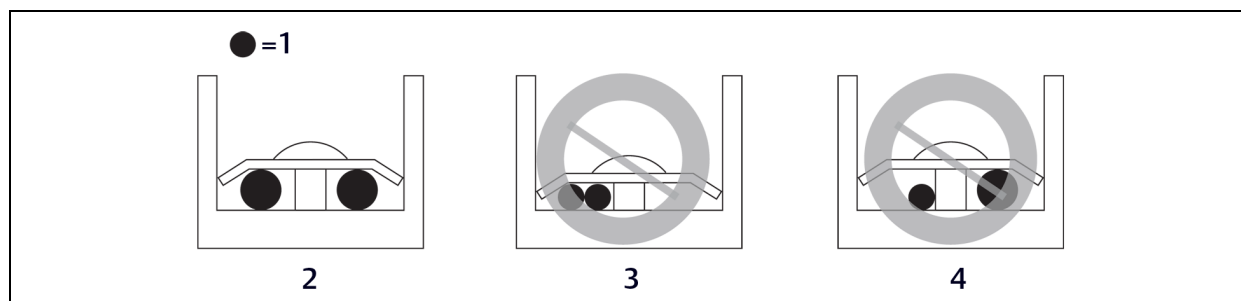

ITEM	DESCRIPTION
1	Copper wire.
2	Terminate multiple power wires of the same gauge to both sides.
3	Do not terminate two wires on one side.
4	Do not terminate different gauge wires to a terminal block.

8.2 Communication-cable Specifications

- Use a 4 conductor, shielded, stranded cable between the outdoor unit and the indoor unit.
- Minimum 18-gauge shielded CVVS or CPEVS cable.
- Insulation materials as required by local code.
- Rated for continuous exposure of temperatures up to 140°F.
- Maximum allowable cable length: 984 ft.
- Firmly attach the cable. Provide slack but secure in a way to prevent external forces from being imparted on the terminal block.
- Terminate the cable shield to a grounded surface at the outdoor unit only.
- Always verify that the communication cable is connected to a communications terminal on the unit. Never apply line-voltage power to the communication-cable connection. If contact is made, PCBs may be damaged.
- The shield of the communication cable connecting the outdoor unit to the indoor unit should be grounded only to the outdoor-unit frame.
- Tie the shield of each cable segment together using a wire nut at each indoor unit. Maintain polarity through the communication network.
- Never use a common multiple-core communication cable. Each communications bus must be provided a separate cable (that is, between the outdoor unit and indoor unit).

8.3 Communication Cables between the Unit and Controller

- Field-supplied, 18 gauge, stranded 4-conductor communication cable (shielded).
- All insulation material as recommended by local code.
- Starting at the outdoor unit, terminate the cable on terminals Internet A and Internet B. Route the cable as needed between each device.

8.4 Connecting Outdoor Unit Electrical Wiring



WARNING! Arc flash and electric shock hazard. Open all local and remote electric power-supply disconnect switches, verify with a voltmeter that power is Off and wear personal protective equipment (PPE) per NFPA 70E before working within the electric control enclosure. Failure to comply can cause serious injury or death. Customer must provide earth ground to unit, per NEC, CEC and local codes, as applicable. Before proceeding with installation, read all instructions, verify that all the parts are included and check the nameplate to be sure the voltage matches available utility power. The Liebert controller does not isolate power from the unit, even in the “Unit Off” mode. Some internal components require and receive power even during the “Unit Off” mode of the controller. The only way to ensure that there is NO voltage inside the unit is to install and open a remote disconnect switch. Refer to unit electrical schematic. Follow all local codes.

The general guidelines for the electrical and communication cables to the outdoor unit are the same for each system. However, the actual connections on the terminal block will differ. Refer to each figure for the model you are installing for the correct wiring of each terminal block.

- Verify that a circuit breaker or some other emergency-power cutoff device is in place before any power wiring is done to the system.
- Never touch any power lines or live cables before power is cut-off to the system.

- Familiarize yourself with the location of the circuit breaker.

To connecting the wiring:

1. Using a Phillips-head screwdriver, remove the conduit-panel cover from the outside of the unit.
2. Inspect all wiring inside the casing to make sure that they are secure and have not come loose during transportation and installation.
 - Loose wires can cause the wiring to burn-out quickly.
 - Inspect wires for damage or cracks (manufacturing defects).
3. Confirm that the Electrical power-supply capacity is sufficient to run the unit. Refer to the specifications in [Electrical Data](#) on page 21.
4. Confirm that you are using the correct wire gauge size to proceed.
5. Using a screwdriver, refer to Figure 8.4 below, and connect the wires as follows:
 - Securely attach each wire to the terminal block.
 - Bundle cabling using a cable restrainer.
 - Pay attention to the location/connection of the green/yellow grounding cable. In some models, the connection is located on the side of the actual terminal block.
 - Maintain a minimum of 0.2-in. of wire length from the terminal block to cable bundle.

Figure 8.4 Outdoor-unit terminal-block connections

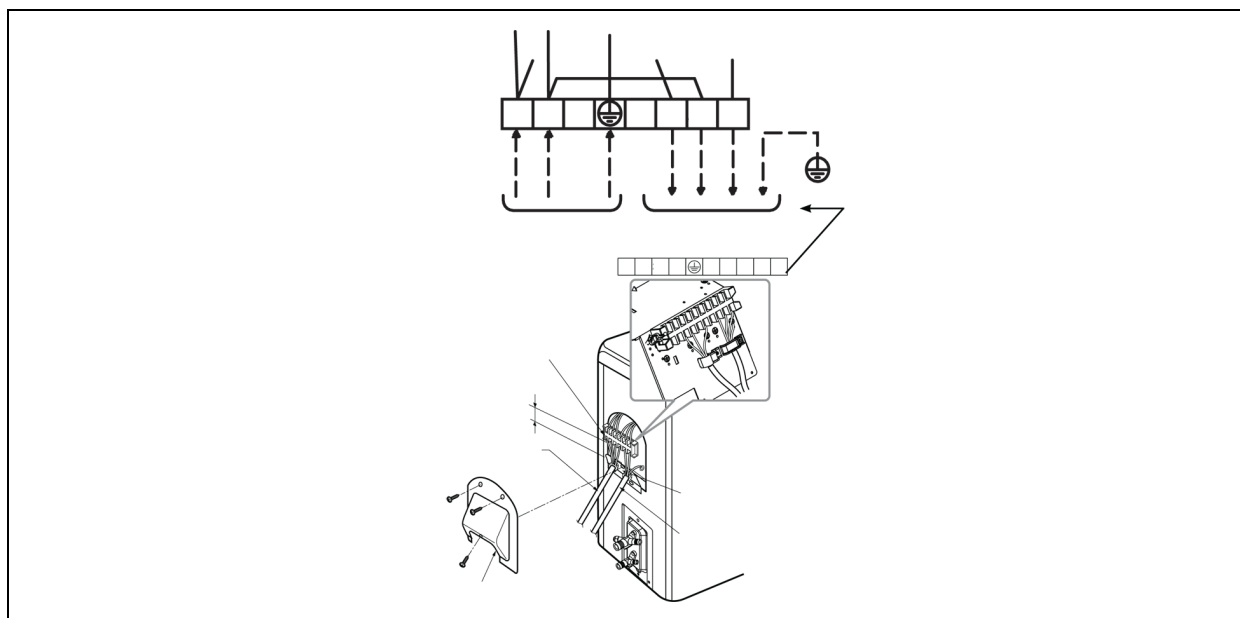

ITEM	DESCRIPTION	ITEM	DESCRIPTION
1	Terminal Block	5	Connection/Communication cable (leading to indoor unit)
2	Power	6	Conduit-panel cover
3	To indoor unit	7	Power cord
4	Conduit panel	8	More than 0.2 in.

- Use a recognized circuit breaker between the power source and the unit. A disconnecting device to adequately disconnect all supply lines must be fitted.

Figure 8.5 below shows an example of how a circuit breaker should be wired through the Liebert SRC system.

Figure 8.5 Circuit breaker wiring

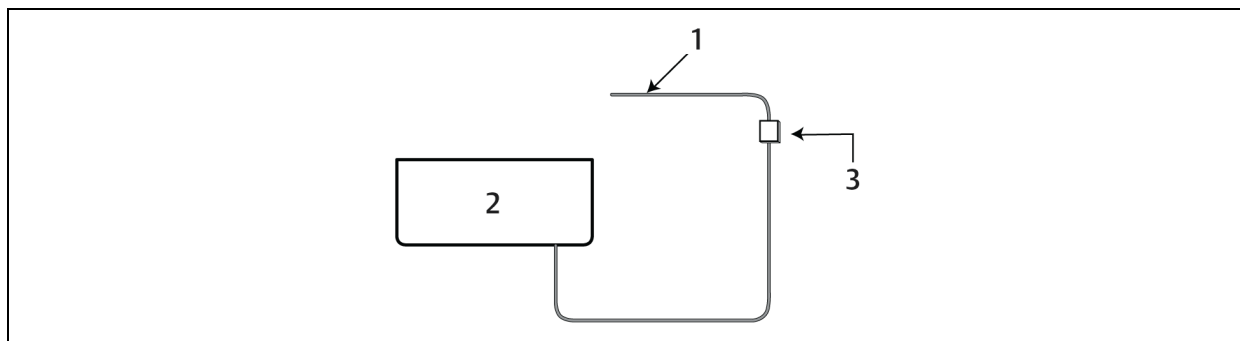

ITEM	DESCRIPTION
1	Main power source
2	Air conditioner
3	Circuit breaker Use a circuit breaker or time-delay fuse.

8.5 Thermostat Installation and Wiring

NOTICE

Risk of improper thermostat installation. Can cause unit malfunction.

- Installation work must be performed in accordance with the national wiring standards and local code by authorized personnel only.
- If local electric and building code requires plenum(CMP) cable, use an enclosed, non-combustible conduit (metal raceway) or FT-6 rated or above cable.
- When using back cable-entry, AWG#22, 3 core shielded wire is recommended.
- When using top or right-side cable entry, AWG#24, 3 core shielded wire is recommended.
- Do not bury the thermostat in the wall. This can damage the temperature sensor.
- Do not install a cable 164 ft (50 m) or longer. This can cause communication errors.

NOTE: If the distance between the thermostat and the indoor unit is longer than 32 ft (10 m), use an extension cable.

Because the room-temperature sensor is in the thermostat, it should be installed in a place away from direct sunlight, high humidity, and direct supply of cold air to maintain proper temperature of the space. Install the thermostat about 5 ft. (1.5 m) above the floor in an area with good air circulation at an average temperature, Figure 8.6 below.

Do not install the thermostat where it can be affected by the following:

- Drafts or dead spots behind doors and in corners.
- Hot or cold air from ducts.
- Radiant heat from sun or appliances.
- Concealed pipes or chimneys.
- Uncontrolled areas such as on an outside wall.

The thermostat is equipped with an LCD display and should be installed at the recommended height for proper view of the display.

Figure 8.6 Proper and Improper thermostat locations

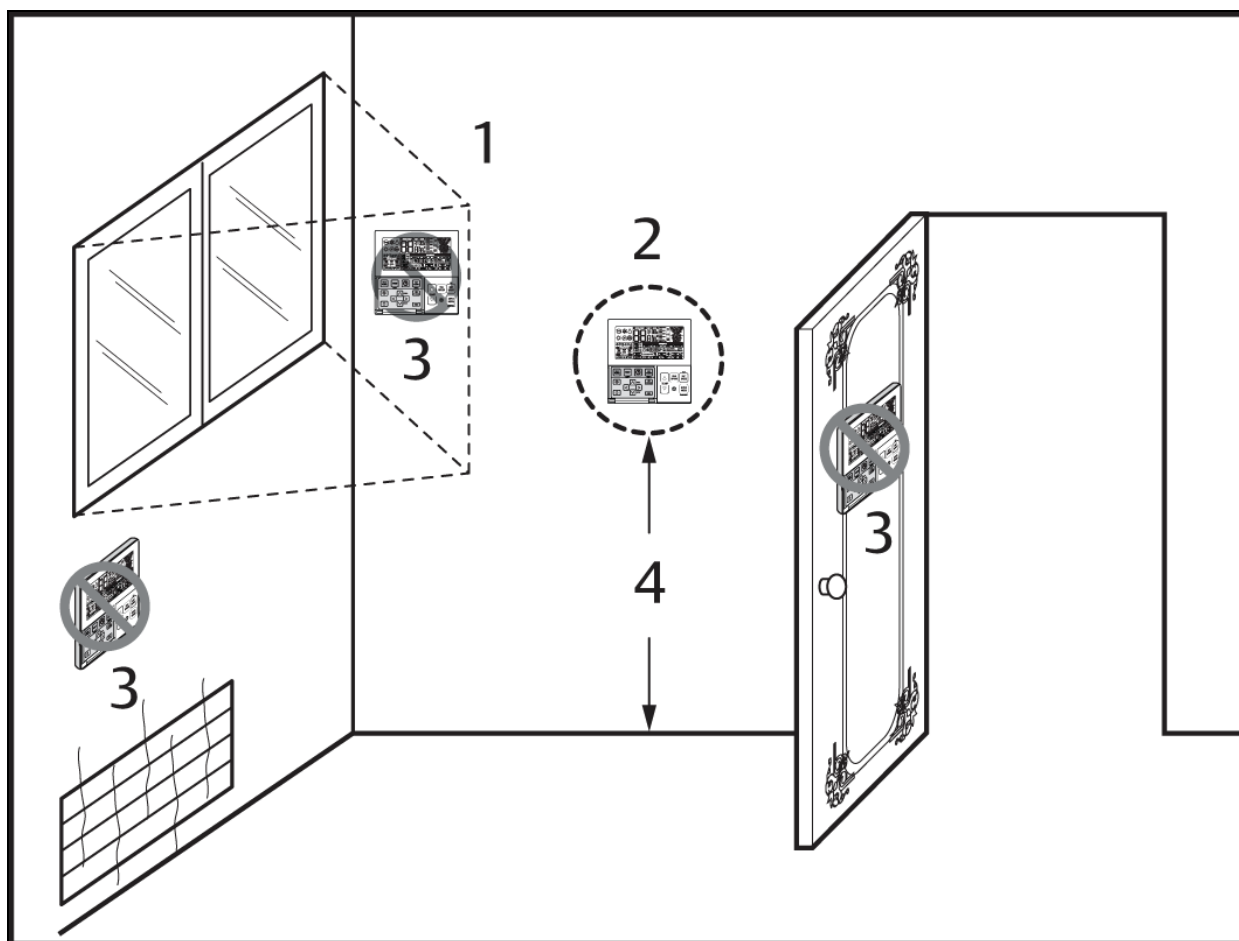

ITEM	DESCRIPTION	ITEM	DESCRIPTION
1	Direct sun-ray contact area	3	Improper location
2	Proper location	4	5 ft (1.5 m) above floor

To install the thermostat:

1. Once the proper location for the thermostat is determined, determine the cable-entry location from one of three options:
 - Back
 - Top
 - Right
2. If you use top or right-side entry, remove the cable-guide groove from the back plate with long-nose pliers, Figure 8.7 below.

Figure 8.7 Cable-entry hole/guide grooves

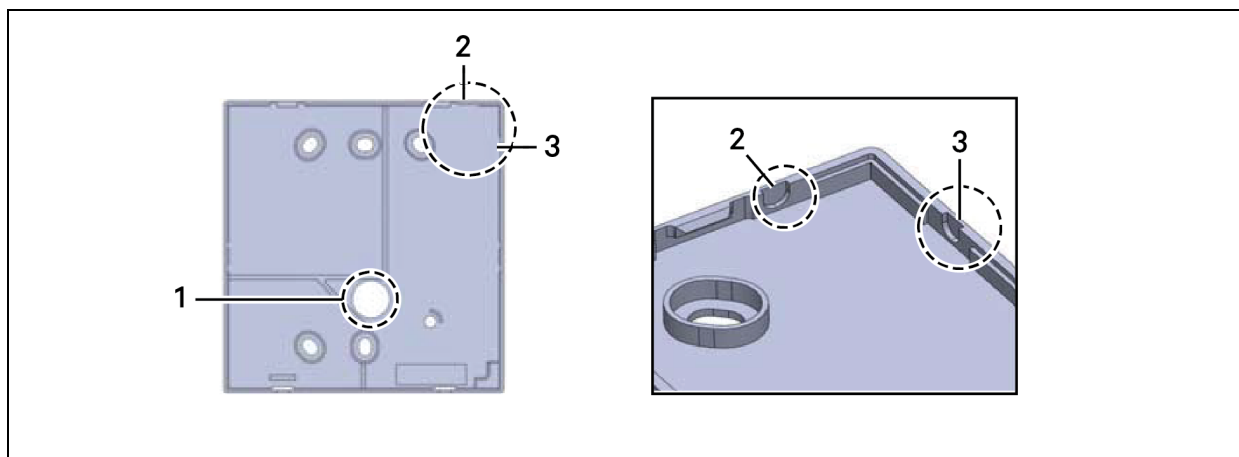

ITEM	DESCRIPTION
1	Back entry (through wall)
2	Top entry
3	Right-side entry

3. Place the back plate in the installation location and secure it with screw, Figure 8.8 below.
 - Do not bend the back plate when tightening screws.
 - If there is an electric box, fit the back plate to the box when installing.
 - Do not leave a gap between the wall and back plate or the thermostat could move or shake.

Figure 8.8 Thermostat back plate installation

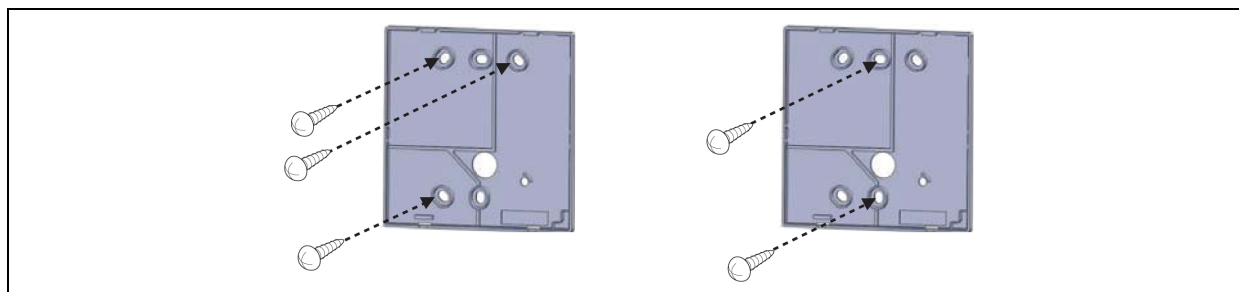

4. Making sure that the cable does not interfere, place the upper part of the thermostat on the back plate as shown in Figure 8.9 below, and press the lower part onto the back plate to connect it.
 - Leave no gaps between the thermostat and the back plate.
 - To remove the thermostat from the back plate, insert a screwdriver into one of the separating holes on the bottom of the thermostat and twist. Repeat in the second hole, to release the thermostat from the back plate.

Figure 8.9 Mounting thermostat onto back plate

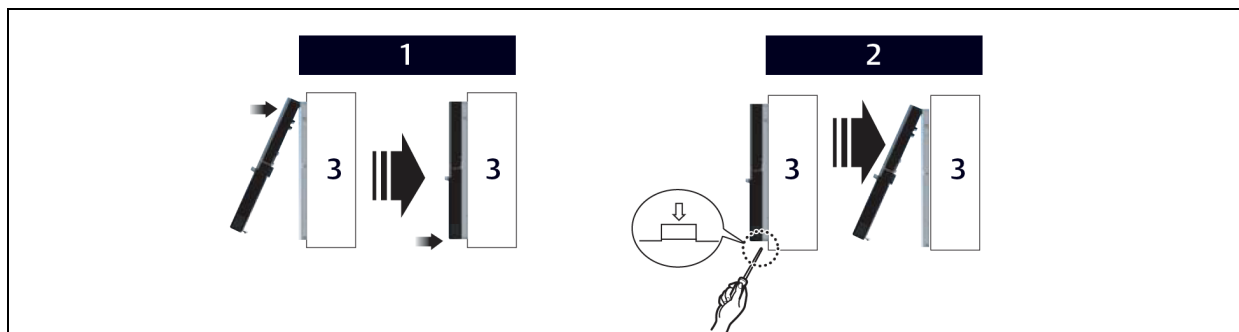

ITEM	DESCRIPTION
1	Connecting order
2	Disconnecting order
3	Wall side

5. Refer to Figure 8.10 below to connect the indoor unit to the thermostat using the extension cable.

NOTICE

Risk of improper thermostat installation. Can cause unit malfunction.

If local electric and building code requires plenum(CMP) cable, use an enclosed, non-combustible conduit (metal raceway) or FT-6 rated or above cable.

Figure 8.10 Extension cable from indoor unit to thermostat

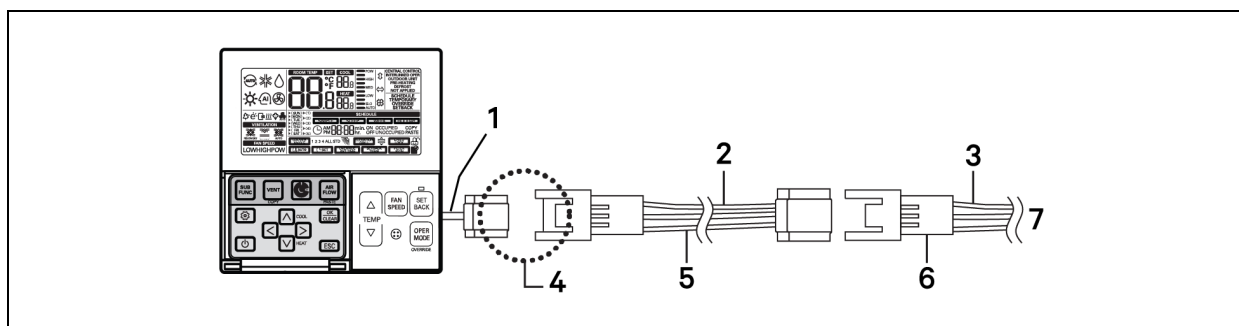

ITEM	DESCRIPTION	ITEM	DESCRIPTION
1	AWG #24	5	Extension cable (housing type)
2	AWG #22	6	C/BOX cable (plug type)
3	AWG #22	7	Indoor-unit side
4	Make sure connectors are properly connected.		

6. To connect the extension cable directly to the thermostat
 - Loosen the screw holding the cable in the thermostat terminal block.
 - Use a cutting nipper to remove the housing from the extension cable and peel it as shown in Figure 8.11 below.

Figure 8.11 Thermostat cable prep

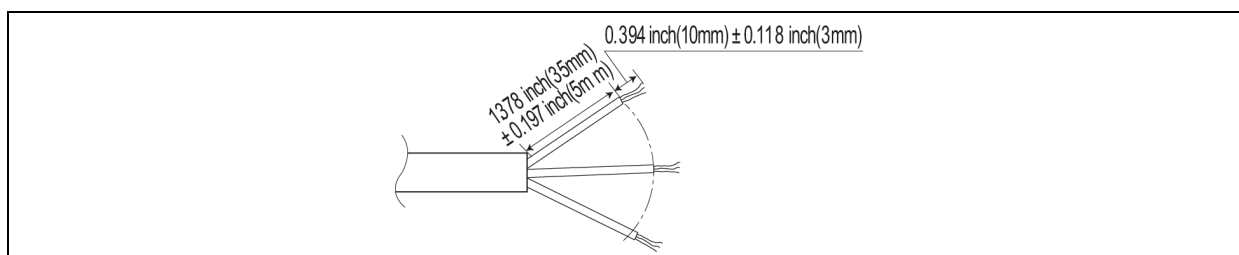

7. Connect the wires to the thermostat terminal block and the indoor-unit terminal block as shown in Figure 8.12 below.

- Tighten securely and make sure wires are not touching each other.

Figure 8.12 Thermostat and Indoor unit terminal-block connections

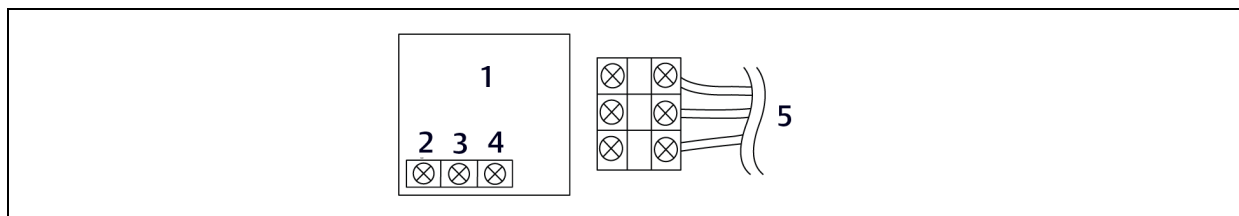

ITEM	1 THERMOSTAT PCB	5 INDOOR-UNIT SIDE	FUNCTION
2	YELLOW	YL	Signal
3	RED	RD	12 V
4	BLACK	BK	GND

This page intentionally left blank.

9 INSTALLATION SET-UP AND SYSTEM START-UP

NOTICE

Risk of improper thermostat installation. Can cause unit malfunction.

The Installer setting mode sets up the detailed function of the thermostat.

If the installation is not set correctly, it can cause problems for the product, user injury, or property damage. Installation set-up must be performed by a certified technician. Non-certified personnel attempting to install or make changes shall be responsible for any adverse effects or operation.

9.1 Accessing Installer Set-up Mode

1. On the thermostat, press  for at least 3 seconds.
The function code displays.

NOTE: A press less than 3 seconds enters “user” settings mode.

2. Refer to the following procedures and Table 9.1 below to make the correct settings for your installation.

NOTE: Some menu options and functions may not be displayed or the menu name may be different depending on your system and model.

Table 9.1 General unit functions—Installer set-up codes

FUNCTION CODE	DESCRIPTION	VALUE
01	Test Run	01 = Set
02	Address Setting	00 ~ FF = Address
03	E.S.P Value	Step: 01 = Very Low 02 = Low 03 = Med 04 = High 05 = Very High
		Value: 0 ~ 255
04	Thermistor	01 = Remo 02 = Indoor 03 = 2TH
05	Ceiling Height	01 = Low 02 = Med 03 = High 04 = Very High

Table 9.1 General unit functions—Installer set-up codes (continued)

FUNCTION CODE	DESCRIPTION	VALUE
06	Static Pressure	01 = V-H 02 = F-H 03 = V-L 04 = F-L
07	Master setting	00 = Slave 01 = Master (only "Plus 1 series models") 00 = Group 01 = Single
08	Override setting	00 = Slave 01 = Master
09	Dry contact	00 = Auto-off 01 = Auto-on
12	Celsius/Fahrenheit	00 = Celsius 01 = Fahrenheit
18	Emergency heater	Select mode: 00 = not used 01 = use Low-ambient heating operation: 0 = not used 1 = compressor off 0°F (-18°C)/ on 5°F (-15°C) 2 = compressor off 5°F (-15°C)/ on 10°F (-12°C) 3 = compressor off 10°F (-12°C)/ on 15°F (-9°C) Fan speed: 0 = fan off 1 = fan on
20	Plasma	00 = not installed 01 = installed
21	Electric heater	
22	Humidifier	
23	Elevation grill	
24	Ventilation kit	
25	Auxiliary heater	
31	Settings temperature range	00 = 60~86°F / 16~30°C 01 = 40~99°F / 4~37.5°C

Some menu options and functions may not be displayed or the menu name may be different depending on your system and model.

9.2 Running Test Mode

Before running test mode, make sure of the following:

- Leak testing is complete and there are no leaks.
 - Air purge/evacuation is complete and successful.
 - All tubing, piping, and wiring are properly connected.
1. On the thermostat, press  for at least 3 seconds.
The function code blinks in the lower-middle of the display.

NOTE: A press less than 3 seconds enters “user” settings mode.









2. Press .
The test run starts.
 - During the test run, pressing any of the following buttons will exit the test: Oper Mode, Temp up/down, Fan Speed, Wind Direction, or Start/Stop.

9.3 Setting the Address of Central Control

Refer to 9.1 on page 101 for the specific function-setting values.

1. On the thermostat, press  for at least 3 seconds.
The function code blinks in the lower-middle of the display.

NOTE: A press less than 3 seconds enters “user” settings mode.

2. Press  repeatedly to select the function code.
3. Press , to select the Group No., then use   to select the setting.
4. Press , to select the Indoor No., then use   to select the setting.
5. Press .
The setting is saved.
6. Press  to exit installer setting mode.

NOTE: If there is no button input for 25 seconds, set-up mode is automatically exited. If you exit without pressing , your settings are not saved.

9.4 Setting E.S.P.













This function determines the wind-strength for each wind level.

Refer to Table 9.1 on page 101 for the specific function-setting values.

NOTE: If E.S.P is set incorrectly, the unit may malfunction. ESP may not work on products that do not have “weak” or power fan-speed settings.

1. On the thermostat, press  for at least 3 seconds.
The function code blinks in the lower-middle of the display.

NOTE: A press less than 3 seconds enters “user” settings mode.

2. Press  repeatedly to select the function code.
3. Press  to select the Step (wind level).
4. Press  to select the Value (wind strength), then use   to select the setting.
5. Press  then   to select the next Step.
6. Press  to select the Value, then use   to select the setting.
7. Repeat 5 to 6 until the strength is set for each wind level.
8. Press .
The setting is saved.
 - Press  to exit installer setting mode.





NOTE: If there is no button input for 25 seconds, set-up mode is automatically exited. If you exit without pressing , your settings are not saved.

9.5 Setting the Thermistor

Refer to Table 9.1 on page 101 for the specific function-setting values.

1. On the thermostat, press  for at least 3 seconds.
The function code blinks in the lower-middle of the display.

NOTE: A press less than 3 seconds enters “user” settings mode.

2. Press  repeatedly to select the function code.
3. Press  to select Value, then use   to select the setting. Refer to Table 9.2 on the facing page for descriptions of the thermistor settings.

4. Press .
The setting is saved.
5. Press to exit installer setting mode.

NOTE: If there is no button input for 25 seconds, set-up mode is automatically exited. If you exit without pressing , your settings are not saved.

Table 9.2 Thermistor setting options

VALUE		FUNCTION	
01	Thermostat		Operates based on temperature sensor in thermostat.
02	Indoor Unit		Operates based on temperature sensor in indoor unit.
03	2TH	Cooling	Operates based on higher temperature comparing the reading from thermostat temp. sensor and indoor-unit temp sensor.
		Heating	Operates based on lower temperature comparing the reading from thermostat temp. sensor and indoor-unit temp sensor.

The 2TH functions differently depending on product model.
If the indoor temperature is below 10°F, the value for the temperature sensor of the thermostat is displayed regardless of the thermistor setting.

9.6 Setting the Ceiling Height

Refer to Table 9.1 on page 101 for the specific function-setting values.

1. On the thermostat, press for at least 3 seconds.
The function code blinks in the lower-middle of the display.

NOTE: A press less than 3 seconds enters “user” settings mode.

2. Press repeatedly to select the function code.
3. Press , to select the Value, then use to select the setting. Refer to Table 9.3 below for descriptions of the ceiling-height settings.

Table 9.3 Ceiling-height setting options

VALUE		FUNCTION
01	Low	Decrease indoor air-flow rate 1 step from standard level.
02	Medium	Set indoor air-flow rate as standard level.
03	High	Increase indoor air-flow rate 1 step from standard level.
04	Very high	Increase indoor air-flow rate 2 steps from standard level.

4. Press .
The setting is saved.
5. Press to exit installer setting mode.







NOTE: If there is no button input for 25 seconds, set-up mode is automatically exited. If you exit without pressing , your settings are not saved.

9.7 Setting Fahrenheit/Celsius

Refer to Table 9.1 on page 101 for the specific function-setting values.

1. On the thermostat, press  for at least 3 seconds.
The function code blinks in the lower-middle of the display.

NOTE: A press less than 3 seconds enters “user” settings mode.

2. Press  to select the function code.
3. Press , to select Value, then use   to select the setting.
4. Press .
The setting is saved.
5. Press  to exit installer setting mode.

NOTE: If there is no button input for 25 seconds, set-up mode is automatically exited. If you exit without pressing , your settings are not saved.







9.8 Setting Optional Functions

Used when options are added or removed.

Refer to Table 9.1 on page 101 for the specific function-setting values.

1. On the thermostat, press  for at least 3 seconds.
The function code blinks in the lower-middle of the display.

NOTE: A press less than 3 seconds enters “user” settings mode.

2. Press  repeatedly to select the function code.
3. Press , to select the condition, then use   to select the setting.
4. Press .
The setting is saved.
5. Press  to exit installer setting mode.

NOTE: A press less than 3 seconds enters “user” settings mode.





9.9 Setting Temperature Range

Refer to Table 9.1 on page 101 for the specific function-setting values.

1. On the thermostat, press  for at least 3 seconds.
The function code blinks in the lower-middle of the display.

NOTE: A press less than 3 seconds enters “user” settings mode.

2. Press  repeatedly to select the function code.

3. Press , to select the Value, then use   to select the setting.
4. Press .
The setting is saved.

NOTE: If there is no button input for 25 seconds, set-up mode is automatically exited. If you exit without pressing , your settings are not saved.

This page intentionally left blank.

10 OPERATION

10.1 Operating the Unit

Use the ON/OFF button on the indoor unit to operate the system.

1. Depending on the type of unit, Type 1 or Type 2, see Figure 10.1 below, open the front cover.
2. Press the ON/OFF button.
 - If the horizontal vane opens rapidly, the stepping motor may be broken.
 - The fan speed is set too high. Depending on the model, fan speed may be changed.
 - You cannot change temperature using this ON/OFF button.
 - For cooling-only models, the temperature is set to 71.6°F (22°C).
 - For cooling-and-heating models, the temperature is set from 71.6°F (22°C) to 75.2°F (24°C).

Figure 10.1 On/Off button location

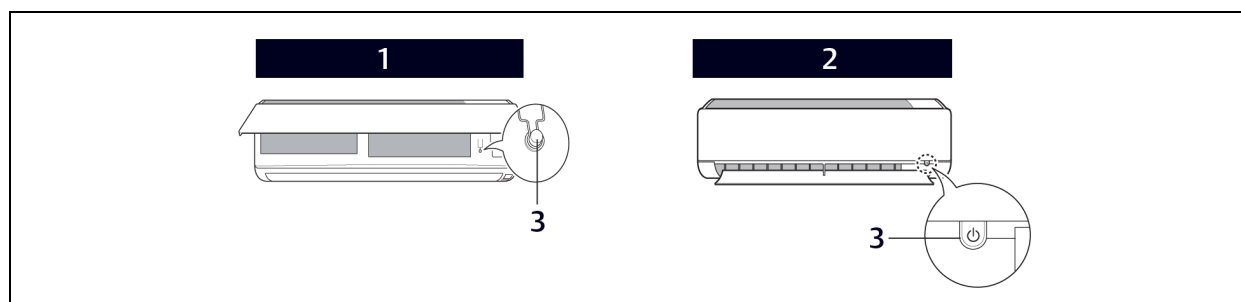

ITEM	DESCRIPTION
1	Type 1
2	Type 2
3	On/Off

10.2 Automatic Unit Restart

When the unit is turned-on after a power failure, this function restores the previous settings.

NOTE: Auto-restart may be changed depending on the type of model.

To disable automatic restart:

1. Open the front cover of the indoor unit.
2. Press and hold the ON/OFF button for 6 seconds.
The unit beeps twice and the lamp blinks 4 times.
 - To re-enable Auto Restart, press and hold the ON/OFF button for 6 seconds.
The unit beeps twice and the lamp blinks 4 times.

NOTE: Pressing and holding the ON/OFF button 3 to 5 seconds, instead of 6 seconds, initiates test operation. In test operation, the unit blows strong, cool air for 18 minutes then returns to factory-default settings.

10.3 Enabling Cooling-only Mode

Cooling-only mode is used when performing the Pump Down procedure. Cooling-only mode is set in “Installer” mode.

- Automatic operation is suspended when cooling-only mode is initiated in Installer mode.
- When cooling-only mode is disabled, the unit returns to normal operation.
- Installer mode cannot be initiated if the unit is running. The system must be powered-off completely.
- All Installer-mode function codes must be entered while the system is powered-off (complete system shutdown).
- WLAN module’s communication time will lag by about 1 minute after the unit is powered back on and normal operation resumes.
- Entire lock or Mode lock cannot be set if you set heating or automatic operation through the central controller.

To enable cooling-only mode:

1. Completely shut-down system power.
2. At the thermostat, access Installer mode by pressing  for at least 3 seconds. The function code displays.

NOTE: A press less than 3 seconds enters “user” settings mode.

3. Press  repeatedly to select the function code 45, then power-on the unit. The unit beeps to acknowledge that the code is received.
4. Turn-off power for at least 30 seconds.
5. Turn-on power to the system. Cooling-only mode is enabled.

10.4 Disabling Cooling-only Mode

Cooling-only mode is used when performing the Pump Down procedure. Once pump-down is complete, disable cooling-only and return to normal operation using the following procedure.



1. Completely shut-down system power.
2. At the thermostat, access Installer mode by pressing  for at least 3 seconds. The function code displays.

NOTE: A press less than 3 seconds enters “user” settings mode.

3. Press  repeatedly to select the function code 46, then power-on the unit. The unit beeps to acknowledge that the code is received.
4. Turn-off power for at least 30 seconds.
5. Turn-on power to the system. Cooling-only mode is disabled.

10.5 Standard Operation

10.5.1 Selecting Cooling Mode



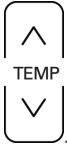

1. On the thermostat, press  to power-on the indoor unit.
2. Press  until  displays in the operation-mode section.

3. Adjust the temperature setting by pressing .



NOTE: The temperature range varies depending on Installer set-up. Factory default is 64~86°F (18~30°C).

10.5.2 Selecting Power Cooling

Power cooling lets you cool or warm the indoor air quickly and is available with cooling, heating, and dehumidification modes.

1. On the thermostat, press  to power-on the indoor unit.
2. Press  until  displays in the operation-mode section.
3. Press  until *Po* displays under the Cooling-temperature setpoint in the temperature section.

10.5.3 Selecting Heating Mode

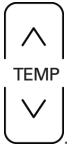

1. On the thermostat, press  to power-on the indoor unit.
2. Press  until  displays in the operation-mode section.

3. Adjust the temperature setting by pressing .

NOTE: The temperature range varies depending on Installer set-up. Factory default is 64~86°F (18~30°C).



10.5.4 Selecting Dehumidification Mode

Dehumidification removes moisture from a highly-humid environment, especially during the rainy season, to prevent mold from setting-in. Dehumidification mode adjusts room temperature and fan speed automatically to maintain the optimal humidity level.

1. On the thermostat, press  to power-on the indoor unit.
2. Press  until  displays in the operation-mode section.

10.5.5 Selecting Fan Mode





Fan mode circulates indoor air without changing the room temperature.

1. On the thermostat, press  to power-on the indoor unit.
2. Press  until  displays in the operation-mode section.

10.5.6 Selecting Auto Mode

Auto mode changes modes automatically to maintain the temperature setpoint within $\pm 3.6^{\circ}\text{F}$ ($\pm 2^{\circ}\text{C}$).

When operating in auto mode, the Auto icon and cool, heat, etc. icon display simultaneously in the Operating Mode section to indicate the current mode.

1. On the thermostat, press  to power-on the indoor unit.
2. Press  until  displays in the operation-mode section.
3. Set the cooling setpoint by pressing , then adjust the temperature displayed

under Cool-temperature setpoint in the Temperature section of the display by pressing



4. Set the heating setpoint by pressing , then adjust the temperature displayed

under Heat-temperature setpoint in the Temperature section of the display by pressing

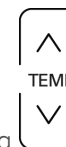



10.5.7 Selecting Timed Override

Timed override temporarily overrides the current schedule (occupied/unoccupied).

- Reverts to last occupied schedule in unoccupied override.
- Reverts to last unoccupied schedule in occupied override.

See [Setting Override Time](#) on page 115, to set the duration of the override.

Press  for 3 seconds.
Timed override is enabled.

- To cancel timed override, press  for 3 seconds.
Operation reverts to last weekly schedule.

10.5.8 Selecting Set Back

Set Back reverts to the last unoccupied schedule until set-back operation is canceled. If there is no unoccupied schedule, it returns to the default set-back setting. See [Setting Set-back Temperature](#) on page 116, to set the set-back setting.

Press .
Set back is enabled.

- To cancel set back, press .



NOTE: You cannot change settings in set-back mode. HL and the lock is displayed. Set back is canceled if a command from another controller is received.

10.5.9 Setting the Temperature

You can adjust the temperature simply by pressing .

NOTE: In Auto mode, both setpoints adjust automatically when you set the temperature in this way. To adjust the cooling or heating setpoint individually, press the appropriate button before adjusting the temperature.





10.5.10 Adjusting Air Flow

1. Press  to cycle through the fan-speed options (displayed in Fan Speed section).
2. Press  to cycle through the wind-direction options (displayed in Air-flow/Louvers section).

10.5.11 Selecting Energy-saving Cooling





Energy-saving cooling operation improves comfort and power-saving capacity by automatically adjusting temperature during cooling mode.

NOTE: Energy-save mode can only be set up in Cooling mode and does not operate with Auto Mode.

1. Press  until  is displayed in the sub-function section of the display.
2. Press .
The setting is saved.
3. Press  to exit the sub-function set-up.





10.5.12 Selecting Automatic Drying

Automatic drying dries the inside of the indoor unit when it is turned-off by operating the fan to remove moisture and prevent mold.

1. Press  until  is displayed in the sub-function section of the display.
2. Press .
The setting is saved.
3. Press  to exit the sub-function set-up.

10.5.13 Selecting Fan Auto

Operates the fan when the outdoor unit is running.







1. Press  until  is displayed in the sub-function section of the display.
2. Press .
The setting is saved.
3. Press  to exit the sub-function set-up.



10.6 Function Settings

10.6.1 Setting Louver Angle Control

Adjusts the angle of airflow.

NOTE: While louver/vane angle is adjusted, commands from the central controller are delayed for 1 minute

1. Press  repeatedly until  flashes in the Function Settings section of the display.
2. Press   to select the vane number, or *All* to set all vanes at once ^{1,2,3,4 ALL STD} (STD sets all louvers to factory-default).
3. Press   to select the angle, then press .







4. Repeat 2 and 3 for each louver if needed.
5. When done, Press .
The settings are saved.
6. Press  to exit the function set-up.

10.6.2 Locking the Display















Locks the display to prevent un-authorized use.

1. Press  repeatedly until  flashes in the Function Settings section of the display.
2. Press   to select , then press .
The display is locked.
3. Press  to exit the function set-up.







10.6.3 Setting the Minimum Difference between the Cooling and Heating Setpoints

1. Press  repeatedly until  flashes in the Function Settings section of the display.
2. Press   to select the temperature, then press .
The minimum difference is set.
3. Press  to exit the function set-up.



10.6.4 Setting Current Time

1. Press  repeatedly until  flashes in the Function Settings section of the display.
2. Press   to select the current day, then press  to move to AM/PM setting.
3. Press   to select AM/PM, then press  to move to hour setting.
4. Press   to select the hour, then press  to move to minute setting.
5. Press   to select minute, then press .
Current time is set.
6. Press  to exit the function set-up.



10.6.5 Setting Override Time

1. Press  repeatedly until  flashes in the Function Settings section of the display.
2. Press   to select the duration of the override interval from 30 to 240 minutes.
3. Press .
Override interval is set.
4. Press  to exit the function set-up.



10.6.6 Setting Set-back Temperature

1. Press  repeatedly until  flashes in the Function Settings section of the display, and the Cool setpoint temperature flashes in the Temperature section.





2. Press  to select the set-back cooling setpoint, then press , to move to the Heat setpoint temperature.



3. Press  to select the set-back heating setpoint, then press . The set-back setpoint temperatures are set.

4. Press  to exit the function set-up.

10.6.7 Clearing the “Clean Filter” Alarm

1. Press  repeatedly until  flashes in the Function Settings section of the display.

2. Press . The display is cleared.



3. Press  to exit the function set-up.

10.7 Schedule Set-up

10.7.1 Simple Schedule

A simple schedule automatically runs for a specified time then stops.

1. On the thermostat, press  until  displays in the Schedule section.

2. Press   to select the sleep time from 1 to 3 hours.

3. Press . The schedule is set.

4. Press  to exit the function set-up.

10.7.2 Setting a Sleep Schedule

A sleep schedule shuts-off the unit for a specified time.

1. On the thermostat, press  until  displays in the Schedule section.

2. Press   to select the duration of the schedule from 1 to 7 hours.

3. Press . The schedule is set.

4. Press to exit the function set-up.

10.7.3 Setting a Weekly Schedule



A weekly schedule sets up daily-operation schedules for the week.

1. On the thermostat, press until displays in the Schedule section.
2. Press to select the day, then press to move to the timer section.
3. Press to select the timer number, then press to move to AM/PM section.
4. Press to select AM or PM, then press to move to the hour section.
5. Press to select the hour, then press to move to the minute section.
6. Press to select the minute, then press to move to the ON/OFF section.
7. Press to select On or Off, then press to move to the OCCUPIED/UNOCCUPIED section.
8. Press to select Occupied or Unoccupied, then press to move to the Operation Mode section.
The operating-mode icon blinks.
9. Press to select the operating mode, then press .
10. Set the cooling setpoint for the schedule, then press .
11. Set the heating setpoint for the schedule, then press to move to the Fan Speed section.
12. Press to select the fan speed, press .
The schedule is set.
13. Press to exit the function set-up.

10.7.4 Copying/Pasting a Schedule

You can copy a weekly schedule to another day.

1. On the thermostat, press until displays in the Schedule section.
2. Press to select the day to copy, then press for 3 seconds.
The COPY icon flashes in the Schedule section.

3. Press   to select day to which you want to paste the schedule, then press  for 3 seconds.



The  icon flashes in the Schedule section, and the schedule is pasted.

4. Press  to exit the function set-up.

10.7.5 Scheduling a Holiday

Schedules stop on the day reserved.

1. On the thermostat, press  until  displays in the Schedule section.
2. Press   to select the day, then press . The holiday is set.
3. Press  to exit the function set-up.

10.7.6 Delete all Schedules

On the thermostat, press and hold  and  simultaneously for 3 seconds.

11 MAINTENANCE

! **WARNING!** Arc flash and electric shock hazard. Open all local and remote electric power disconnect switches, verify with a voltmeter that power is Off and wear personal protective equipment (PPE) per NFPA 70E before working within the electric control enclosure. Failure to comply can cause serious injury or death. The Liebert controller does not isolate power from the unit, even in the “Unit Off” mode. Some internal components require and receive power even during the “Unit Off” mode of the controller. The only way to ensure that there is NO voltage inside the unit is to install and open a remote disconnect switch. Refer to unit electrical schematic. Follow all local codes.

NOTICE

Risk of improper cleaning. Can cause cabinet finish damage.

- Never use water that is higher than 104° (40°C) when you clean the filters. It may cause deformation or discoloration.
- Never use volatile substances when you clean the filters. These may damage the surface of the unit.
- Do not wash the 3M filter (optional) with water because it can be damaged by water.
- Do not wash the Triple filter (optional) with water because it can be damaged by water.

If the unit will not be used for an extended period of time, dry the unit to maintain it in the best condition. Clean the unit regularly to maintain optimal performance and to prevent possible breakdown. For the cleaning schedule, see [Cleaning Schedule](#) on the next page.

- Dry the unit in Fan mode for 3 to 4 hours and disconnect the power. There may be internal damage if moisture is left in unit’s components.
- Before using the unit again, dry the unit in Fan mode for 3 to 4 hours to remove odor generated by moisture.

Figure 11.1 Cleaning the outside of the indoor unit

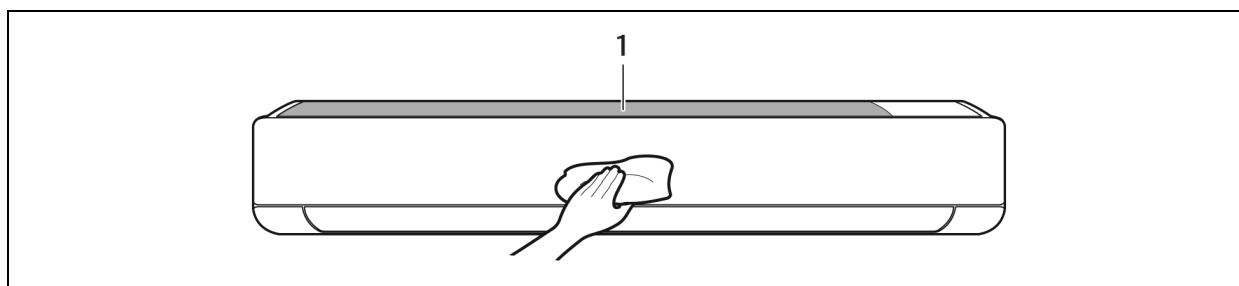

ITEM	DESCRIPTION
1	Air filter

Table 11.1 Cleaning Schedule

COMPONENT	DESCRIPTION	INTERVAL
Air filter	Clean with a vacuum or hand wash.	2 weeks
Triple filter	Clean with a vacuum or brush.	Every 3 months
3M filter	Clean with a vacuum or brush.	Every 6 months
Ionizer (optional)	Use a dry cotton bud to remove any dust.	Every 6 months
Indoor unit	Clean the surface using a soft, dry cloth.	Regularly
	Have a professional clean the condensate drain pan.	Once a year
	Have a professional clean the condensate drain pipe.	Every 4 months
Outdoor unit	Have a professional clean the heat-exchanger coils and the panel vents. (Consult a technician.)	Once a year
	Have a professional clean the fan.	Once a year
	Have a professional clean the condensate drain pan	Once a year
	Have a professional verify that the fan assembly is firmly tightened.	Once a year
	Clean the electric components with air.	Once a year

11.1 Cleaning the Air Filter

Clean the air filter once every 2 weeks or more if necessary.

Note the following guidelines:

- Bending the air filter can break it.
- If the air filter is not assembled correctly, dust and other substances can enter the indoor unit.

11.1.1 Cleaning the Air Filter on Type 1 Units

1. Turn-off power and unplug the power cord.
2. Open the front cover by lifting both sides of the cover slightly.
3. Hold the knobs on the air filters, pull them down slightly and remove them from the unit, Figure 11.2 below.

Figure 11.2 Removing the air filter from Type 1 unit

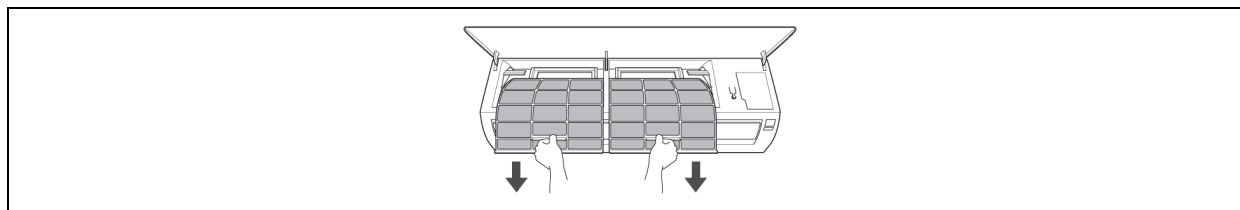

4. Clean the filters with a vacuum cleaner or lukewarm water with a neutral detergent.
5. Dry the filters in the shade.
6. Insert the hooks of the air filters into the front cover, Figure 11.3 below, and make sure the filters are inside the cover for correct assembly.

Figure 11.3 Inserting cleaned air filter in Type 1 unit

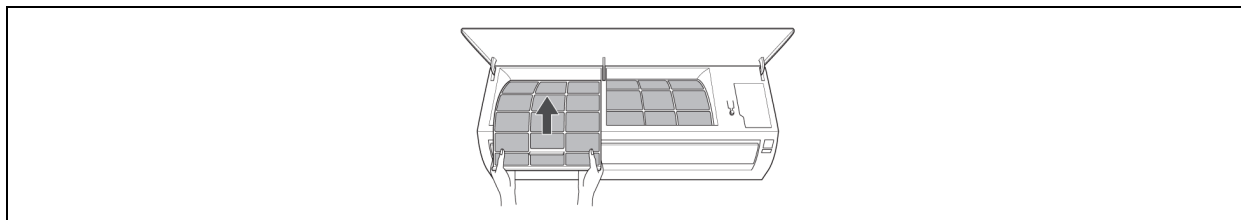

11.1.2 Cleaning the Air Filter on Type 2 Units

1. Turn-off power and unplug the power cord.
2. Hold the knobs on the air filters, lift up slightly, Figure 11.4 below.

Figure 11.4 Knobs on air filter of Type 2 unit

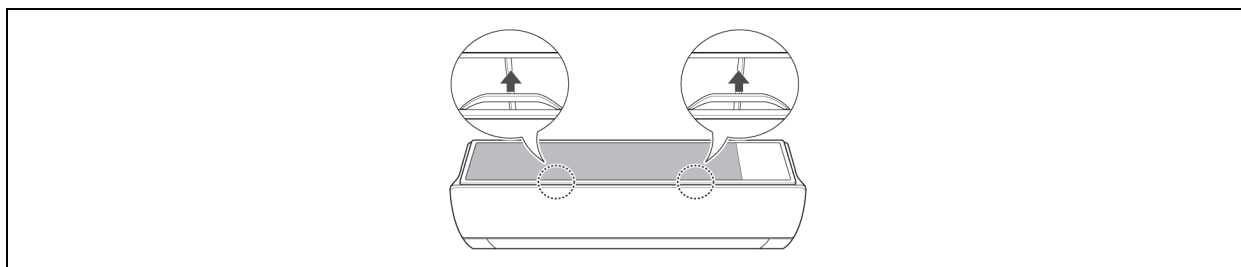

3. Remove them from the unit, Figure 11.5 below.

Figure 11.5 Removing the air filter from Type 2 unit

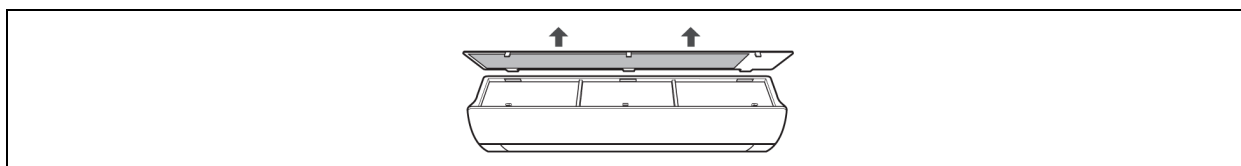

4. Clean the filters with a vacuum cleaner or lukewarm water with a neutral detergent.
5. Dry the filters in the shade.
6. Insert the hooks of the air filters into the front cover, Figure 11.6 below.

Figure 11.6 Inserting cleaned air filter on the hooks of the Type 2 unit

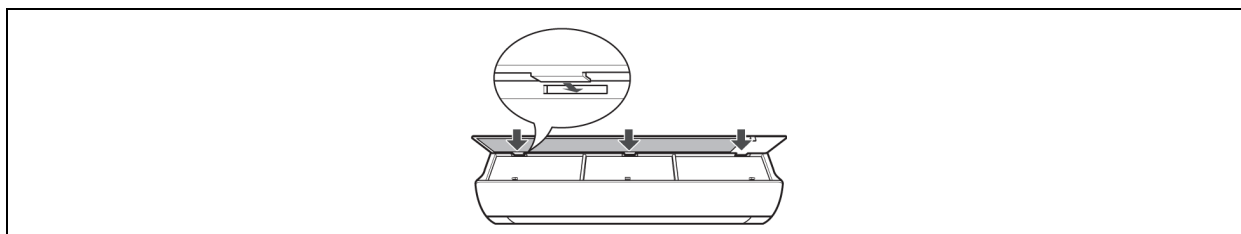

7. Press down onto hooks, Figure 11.7 below, and make sure the filters are installed correctly.

Figure 11.7 Push down on the hooks of the Type 2 unit

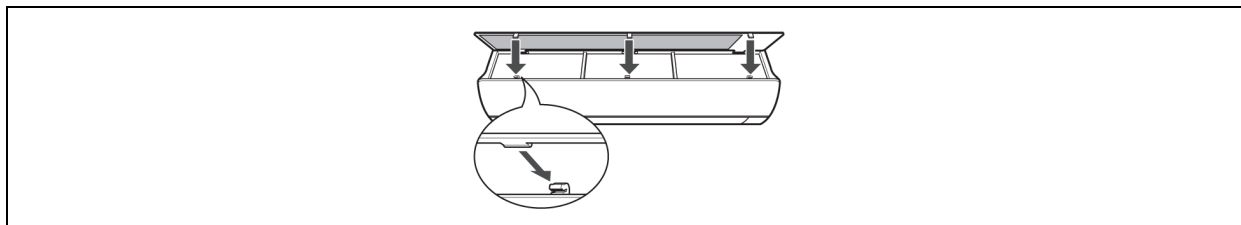

11.2 Cleaning the Optional 3M or Triple Filter

1. Turn off power and unplug the power cord.
2. Remove the air filters from the unit.
3. Remove the 3M and/or Triple filters from the unit, Figure 11.8 below.

Figure 11.8 Removing 3M/Triple filters from indoor unit

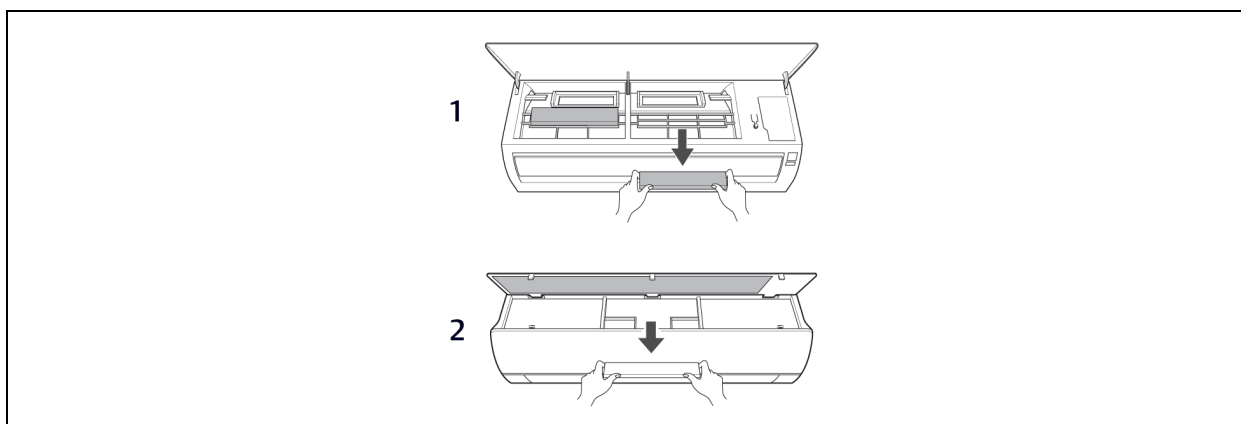

ITEM	DESCRIPTION
1	Type 1
2	Type 2

4. Clean the filters with a vacuum cleaner.
5. Insert the 3M and/or Triple filters in the unit, Figure 11.9 below.

Figure 11.9 Replacing 3M/Triple filters in the indoor unit

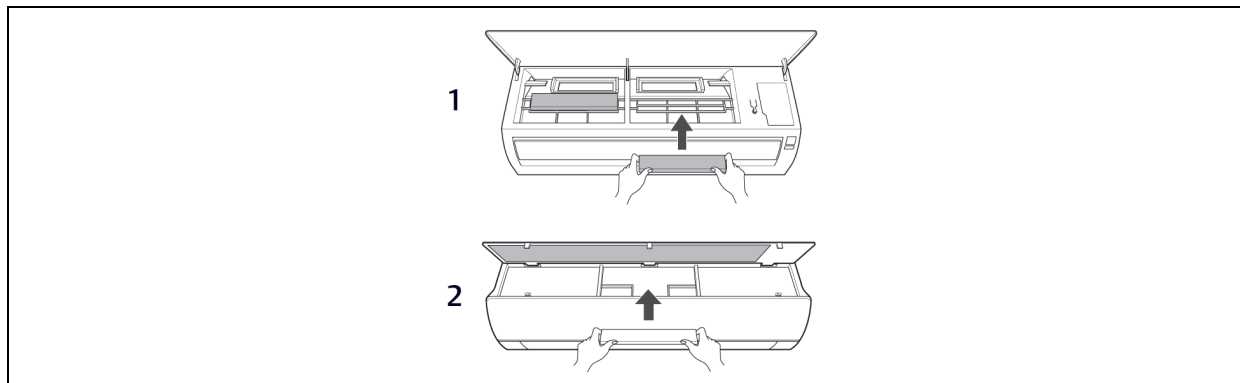

ITEM	DESCRIPTION
1	Type 1
2	Type 2

6. Replace the air filters.
7. Check the sides of the front cover to make sure the air filters are installed correctly.

This page intentionally left blank.

12 TROUBLESHOOTING

12.1 Self-diagnosis at the Indoor Unit

The Liebert SRC has a built-in self-diagnosis function. If an error occurs, the lamp of the indoor unit blinks in 2-second intervals. If this occurs, contact your dealer or service center.

12.2 Before Calling for Service

Please check Table 12.1 below before contacting service. If the problem persists after corrective action, contact Vertiv™ technical support at 1-800-543-2778.

Table 12.1 Self-service troubleshooting

PROBLEM	POSSIBLE CAUSES	CORRECTIVE ACTION
The unit does not work normally.	Burning smell and strange sounds are coming from the unit.	Turn-off the unit, unplug the power cable or disconnect the power supply, and contact service.
	Water leaks from the indoor unit even when humidity level is low.	
	The power cable is damaged or it is generating excessive heat.	
	A switch, circuit breaker (safety, ground), or a fuse is not operating properly.	
	The unit generates an error code from self diagnosis.	
	Incorrect cabling.	
	Incorrect scheduling setup.	Check the programmed Schedule settings.
The unit does not work.	The unit is unplugged.	Check to see if the power cord is plugged into the outlet or if the power isolators are switched on.
	A fuse exploded or the power supply is blocked.	Replace the fuse or check to see if the circuit breaker is tripped.
	Voltage is too high or too low.	Turn off the unit when a power failure occurs. When the power is restored, wait 3 minutes before turning-on the unit.
	The unit was turned-off automatically at a scheduled time.	Turn the unit on.

12.3 Self-diagnosis at the Thermostat

If the unit has a problem, it will self-diagnose with Troubleshooting mode and display “CH” and an error code in the Temperature section of the display, Figure 12.1 on the next page.

NOTE: Verify the thermostat function settings after recovery from an error. The settings could have changed because of communication with the controller in group mode.

Figure 12.1 Error codes displayed at the thermostat

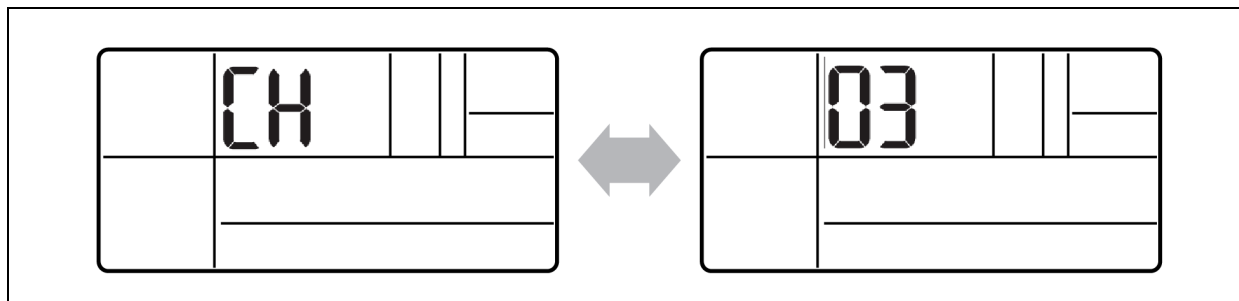

12.4 Troubleshooting Error Codes at the Indoor and Outdoor Units

Table 12.2 on the facing page, lists the most-common error codes that you will see on these units. Some models may display codes not listed here. Please contact service if a power-down/reboot does not correct the issue. Do not attempt to fix the unit yourself.

The error codes indicate different types of failures, assist in self-diagnosis, and helps track frequency of occurrence. Figure 12.2 below and Figure 12.3 on the facing page show where error codes display based on model number.

If two or more errors occur simultaneously, the lower number displays first. When an error is resolved, the number no longer displays.

12.4.1 Decoding Error Display for SRC18

Refer to Figure 12.2 below.

- LED 1 blinks (green) to indicate the second, “ones” digit of the error code.
- LED 2 blinks (red) to indicate the first, “tens” digit of the error code.

For example, if the error code is 21, LED 1 blinks 1 time, and LED 2 blinks 2 times.

Figure 12.2 Error-code display for SRC18

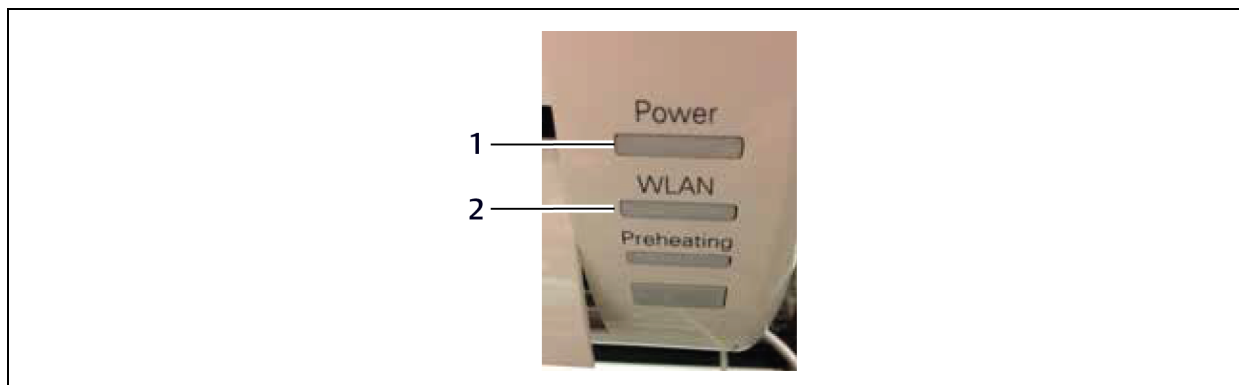

ITEM	DESCRIPTION
1	LED 1 (“ones” digit)
2	LED 2 (“tens” digit)

Decoding Error Display for SRC24 and SRC36

Refer to Figure 12.3 below.

- The digital display blinks “CH” then the error number.

Figure 12.3 Error-code display for SRC24 and SRC36

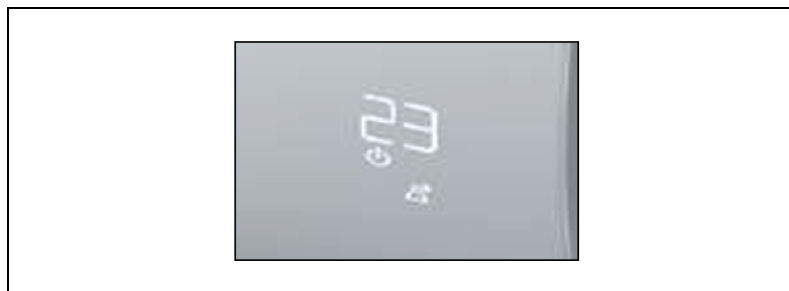

Table 12.2 SRC Error Codes

UNIT	ERROR NO.	DESCRIPTION	INDOOR UNIT LED	SRC18 LED BLINKS		SRC24 AND SRC36 DISPLAYS
				LED 1 (2ND DIGIT)	LED 2 (1ST DIGIT)	
Indoor	1	Indoor unit room-temperature sensor error	ū	1x	–	CH01
	2	Indoor unit inlet pipe sensor error	ū	2x	–	CH02
	3	Wired remote-control error	ū	3x	–	CH03
	4	Float switch (optional) error	ū	4x	–	CH04
	5	Communication error between indoor and outdoor unit	ū	5x	–	CH05
	6	Indoor unit outlet-pipe sensor error	ū	6x	–	CH06
	9	Indoor unit EEPROM error	ū	9x	–	CH09
	10	Indoor unit BLDC motor fan lock	ū	–	1x	CH10
	12	Indoor unit middle pipe sensor error	ū	2x	1x	CH12

Table 12.2 SRC Error Codes (continued)

UNIT	ERROR NO.	DESCRIPTION	INDOOR UNIT LED	SRC18 LED BLINKS		SRC24 AND SRC36 DISPLAYS
				LED 1 (2ND DIGIT)	LED 2 (1ST DIGIT)	
Outdoor	21	DC Peak (IPM fault)	ū	1x	2x	CH21
	22	CT 2 (Max CT)	ū	2x	2x	CH22
	23	DC Link Low/High Volt	ū	3x	2x	CH23
	26	DC Comp Position Error	ū	6x	2x	CH26
	27	PSC Fault	ū	7x	2x	CH27
	29	Comp Phase Over-current	ū	9x	2x	CH29
	32	Invert Compressor D-pipe Overheat	ū	2x	3x	CH32
	38	Refrigerant Leak detection	ū	8x	3x	CH38
	37	Exceed the Compression Ration Limit	ū	7x	3x	CH37
	41	D-pipe Sensor Error	ū	1x	4x	CH41
	44	Outdoor Air Sensor Error	ū	4x	4x	CH44
	45	Cond. Out Pipe High	ū	8x	4x	CH45
	51	Excess Capacity (Mismatching between In/Outdoor unit)	ū	1x	5x	CH51
	53	Communication Error (IN-OUT)	ū	3x	5x	CH53
	60	Outdoor EEPROM Check sum error	ū	–	6x	CH60
	61	Cond. Pipe High	ū	1x	6x	CH61
	62	Heat Sink Sensor Temp. High	ū	2x	6x	CH62
	65	Heat sink Th Error (open/short)	ū	5x	6x	CH65
	67	BLDC Motor Fan Lock	ū	7x	6x	CH67
72	Detect 4 Way Valve Transfer Failure	ū	2x	7x	CH72	
93	Communication Error (IN-OUT)	ū	3x	9x	CH93	

12.5 Troubleshooting Table

Table 12.3 on the facing page lists problems, possible causes, and a corrective action.

Table 12.3 Troubleshooting problems, causes and correction

PROBLEM	POSSIBLE CAUSES	CORRECTIVE ACTION
Unit does not emit cool air	Air is not circulating properly.	Make sure that there are not curtains, blinds, or furniture blocking the front of the unit.
	The air filter is dirty.	Clean the air filter once every 2 weeks. See Cleaning the Air Filter on page 120.
	The room temperature is too high.	In summer, cooling the indoor air fully may take some time. In this case, select Power Cool to cool the indoor air quickly.
	Cold air is escaping from the room.	Make sure that no cold air is escaping through ventilation points in the room.
	The desired temperature is higher than the set temperature.	Set the desired temperature to a level lower than the current temperature.
	There is a heating source nearby.	Avoid using heat generators like electric ovens or gas burners while the unit is operating.
	Fan Mode is selected.	During fan mode, air blows from the unit without cooling or heating the indoor air. Switch the operation mode to cooling.
	Outside temperature is too high.	The cooling effect may not be sufficient.
The fan speed cannot be adjusted.	The Jet Mode or Auto Operation Mode is selected.	In some operation modes, you cannot adjust the fan speed. Select an operation mode in which you can adjust the fan speed.
The temperature cannot be adjusted.	The Fan Mode or Jet Mode is selected.	In some operation modes, you cannot adjust the temperature. Select an operation mode in which you can adjust the temperature.
The unit stops during operation.	The unit is suddenly turned off.	The Timer Function may have timed-out, which turns the unit off. Check the timer/schedule settings.
	A power failure has occurred during operation.	Wait for the power to come back. If you have the Auto Restart function enabled, your unit will resume in its last operation mode several minutes after power is restored.
The indoor unit is still operating even when the power has been turned off.	The Auto Clean function is being operated.	All the Auto Clean function to continue because it removes any remaining moisture inside the indoor unit. If you do not want it to continue, turn the unit off.
The air outlet on the indoor unit is discharging mist.	The cooled air from the unit makes mist.	When the room temperature decreases, the phenomenon will disappear.
Water leaks from the outdoor unit.	In heating operation, condensed water drops from the heat exchanger.	This requires installing a drain hose under the base pan. Contact the installer.

Table 12.3 Troubleshooting problems, causes and correction (continued)

PROBLEM	POSSIBLE CAUSES	CORRECTIVE ACTION
There is a noise or vibration.	A clicking sound can be heard when the unit starts or stops due to movement of the reversing valve. Creaking sound: The plastic parts of the indoor unit creak due to sudden temperature changes. Flowing or Blowing sound: This is the flow of the refrigerant through the unit.	These are normal occurrences. The noise will stop.
The indoor unit gives off an odor.	Odors (such as cigarette smoke) may be absorbed into the indoor unit and discharged with air flow.	If the smell does not disappear, wash the air filter. If this does not work, contact service to clean the heat exchanger.
The unit does not emit warm air.	When Heating Mode starts, the vane is almost closed and no air comes out, even though the outdoor unit is operating.	This is normal. Please wait until the unit has generated enough warm air to blow through the indoor unit.
	The outdoor unit is in Defrosting Mode.	In Heating Mode, ice/frost builds up on the coils when the outside temperature falls. This function removes the layer of frost on the coil and should finish in approximately 15 minutes.
	Outside temperature is too low.	The heating effect may not be sufficient.

Depending on mode, some functions may not be supported.

12.6 Refrigerant Leaks



CAUTION: Risk of exposure to excessive refrigerant concentration and oxygen depletion. Can cause illness or injury. If the unit is installed in a small improperly or non-ventilated space, take measures to prevent the refrigerant concentration from exceeding safety limits in the event of a refrigerant leak. Verify the maximum refrigerant concentration level in the space where the indoor unit will be mounted meets the concentration limit for the application.

NOTE: Take appropriate actions at the end of HVAC equipment life to recover, recycle, reclaim or destroy R410A refrigerant according to applicable US EPA rules.

ASHRAE Standards 15-2010 and 34-2010 offer guidelines that address refrigerant safety and the maximum allowable concentration of refrigerant in an occupied space. Refrigerant will dissipate into the atmosphere, but a certain volume of air is required for this to occur safely. For R410A refrigerant, the maximum allowable concentration is 0.026 lbs/ft³ per 1,000 ft³ of air in an occupied space. Buildings with 24-hour occupancy allow half of that concentration.¹

ASHRAE Standards 15 and 34 assume that if a system develops a leak, its entire refrigerant charge will dump into the area where the leak occurs. To meet ASHRAE Standards 15 and 34, calculate the refrigerant concentration that may occur in the smallest room volume on the system, and compare the results to the maximum allowable concentration number.¹ Also consult state and local codes with regard to refrigerant safety.

To calculate the potential refrigerant concentration level (RCL):

1. Measure the occupied space dimensions (in feet).
2. Calculate the cubic foot volume of air in the smallest occupied space. (To obtain a detailed overview of the RCL, perform the same calculations to the second smallest zone, the third smallest zone until the RCL is obtained for all zones. Also, pay special attention to areas such as basements, etc., where refrigerant cannot dissipate easily.)

3. Divide the refrigerant charge of the Liebert SRC serving the area in pounds by the results of step 1.
4. If the calculation indicates that the potential refrigerant concentration level is higher than the allowed RCL, increase the cubic volume of the smallest occupied space or modify the piping system design.
5. The allowable RCL limit for most applications must be equal to or less than 0.026 lbs/ft³. In special occupied spaces, however, such as hospitals and nursing homes where occupants may have limited mobility, the allowable RCL limit is cut in half. See ASHRAE Standard 34-2007 and local codes for detailed information. (American Society of Heating, Refrigeration and Air Conditioning Engineers, Inc. (ASHRAE). Atlanta, GA. ASHRAE, Inc. Information about ASHRAE Standard 15-2010 / 34-2010 and addenda current as of the date of this publication.).

Figure 12.4 Refrigerant Concentration Limit (RCL) Calculations Equation

Amount of Factory-charged refrigerant per outdoor unit	+	Amount of additional refrigerant trim charge	=	Total system refrigerant charge
$\text{RCL (lbs/ft}^3\text{)} = \frac{\text{Total system refrigerant charge (lbs)}}{\text{Volume of smallest occupied space (ft}^3\text{)}}$				

This page intentionally left blank.

APPENDICES

Appendix A: Technical Support and Contacts

A.1 Technical Support/Service in the United States

Vertiv Services, Inc.

24x7 dispatch of technicians for all products.

1-800-543-2378

Liebert Thermal Management Products

1-800-543-2778

Liebert Channel Products

1-800-222-5877

Liebert AC and DC Power Products

1-800-543-2378

A.2 Locations

United States

Vertiv Headquarters

1050 Dearborn Drive

Columbus, OH, 43085, USA

Europe

Via Leonardo Da Vinci 8 Zona Industriale Tognana

35028 Piove Di Sacco (PD) Italy

+39 049 9719 111

Fax: +39 049 5841 257

Asia

7/F, Dah Sing Financial Centre

3108 Gloucester Road, Wanchai

Hong Kong 852 2572220

Fax: 852 28029250

This page intentionally left blank.



VertivCo.com | Vertiv Headquarters, 1050 Dearborn Drive, Columbus, OH, 43085, USA

© 2017 Vertiv Co. All rights reserved. Vertiv and the Vertiv logo are trademarks or registered trademarks of Vertiv Co. All other names and logos referred to are trade names, trademarks or registered trademarks of their respective owners. While every precaution has been taken to ensure accuracy and completeness herein, Vertiv Co. assumes no responsibility, and disclaims all liability, for damages resulting from use of this information or for any errors or omissions. Specifications are subject to change without notice.

SL-11055_REV3_9-17/590-1630-501A