



# Liebert® Xtreme Density™

System Design Manual

### **Technical Support Site**

If you encounter any installation or operational issues with your product, check the pertinent section of this manual to see if the issue can be resolved by following outlined procedures. Visit <https://www.VertivCo.com/en-us/support/> for additional assistance.



# TABLE OF CONTENTS

---

<b>1 System Description</b>	<b>7</b>
1.1 European Union Fluorinated Greenhouse Gas Requirements	7
1.2 Generic Piping Layouts	8
1.3 Liebert XDA—Air Flow Enhancer	9
1.4 Liebert XDCF—Liebert XD CoolFrame	10
1.5 Liebert XDH—Horizontal Cooling Module	10
1.6 Liebert XDO—Overhead Cooling Module	11
1.7 Liebert XDR—Rear Cooling Module	13
1.8 Liebert XDV—Vertical, Above-Cabinet Cooling Module	13
1.9 Liebert XDC—Refrigerant Chiller	15
1.9.1 Liebert XDC Minimum Load	15
1.10 Liebert XDP—Pumping Unit	15
1.10.1 Liebert XDP Minimum Load	16
1.11 Liebert XD Piping	16
1.11.1 Liebert XD Field Piping	16
<b>2 Starting a New Equipment Cooling Project</b>	<b>19</b>
2.1 Determining Cooling Equipment Needs	19
2.2 Implementing a Hot-Aisle/Cold Aisle Design	19
<b>3 Designing a Liebert XD Solution</b>	<b>21</b>
3.1 Determine Cooling Requirements and Select Liebert XD System	21
3.2 Calculate the Heat Load to be Handled by Liebert XD System	21
3.3 Selecting Liebert XD Cooling Modules	22
3.4 Configuring a Liebert XD System	24
3.4.1 Number of Modules Supported by a Liebert XDP or Liebert XDC	24
3.4.2 System Connection Configuration	25
3.5 Airflow Requirements for Liebert XD Solutions	26
3.6 Liebert XDCF Placement	26
3.7 Liebert XDH Placement	27
3.8 Liebert XDO Placement	28
3.8.1 Determining Spacing of Liebert XDOs in an Aisle	28
3.8.2 Determining Vertical Placement of Liebert XDOs Above the Cold Aisle	29
3.9 Liebert XDR Module Placement	30
3.9.1 Airflow	31
3.10 Liebert XDV Module Placement	32
3.11 Liebert XDP/Liebert XDC Placement	33
3.12 Examples of Expansion and Interlaced Connection of Liebert XD Cooling Modules	34
3.13 Liebert XD Piping System Design	38
3.14 Liebert XD Piping Slope	40
3.15 Bypass Flow Controllers	40
3.16 Piping Details—Shutoff/Isolation Valves	42

3.17 Piping Details—Shutoff/Isolation Valves .....	43
3.18 Piping Details—Return Header Port Orientation .....	44
3.19 Piping Details—Bull Heading Layout .....	46
3.20 Piping Installation Method Prefabricated Headers .....	47
3.21 Liebert XD Flex Pipe Kit .....	54
3.22 Liebert XD Refrigerant .....	55
3.23 Determining Refrigerant Volume .....	56
3.23.1 Liebert XDP/Liebert XDC Pumped R-134a Circuit Volume .....	56
3.23.2 Calculating Refrigerant R134a Charge—Example .....	57
3.24 Chilled Water Piping .....	58
3.25 Electrical .....	60
3.26 Temperature/Humidity Sensor Locations .....	60
3.27 Connecting Liebert XDP and Liebert XD Cooling Modules in a CANbus Network .....	60
3.27.1 CANbus Cables .....	60
3.27.2 CANbus Cable Length in a Network .....	61
3.27.3 Remote Sensor Placement Within the CANbus .....	62
<b>4 Liebert XD Cooling Modules—Liebert XDCF, Liebert XDH, Liebert XDO, Liebert XDR and Liebert XDV .....</b>	<b>65</b>
4.1 Liebert XDCF Standard Features .....	65
4.2 Liebert XDCF Mechanical Considerations .....	65
4.3 Liebert XDCF Installation Considerations .....	67
4.4 Liebert XDCF Piping Connection Methods and Points .....	67
4.4.1 Header System—Liebert XDCF .....	68
4.5 Liebert XDH Standard Features .....	68
4.6 Optional Features—Liebert XDH .....	69
4.7 Connecting High-Voltage Wiring—Liebert XDH .....	71
4.8 Connecting Low-Voltage Wiring—Liebert XDH Smart Modules .....	72
4.9 Liebert XDO Standard Features .....	73
4.10 Optional Features Liebert XDO .....	73
4.11 Low-Voltage Wiring—Liebert XDO Smart Modules .....	80
4.12 Liebert XDR Standard Features .....	81
4.13 Optional Features—Liebert XDR .....	81
4.14 Liebert XDR Installation Considerations .....	82
4.15 Liebert XDV Standard Features .....	86
4.16 Optional Features—Liebert XDV .....	87
4.17 High-Voltage Cabling for Liebert XDV .....	93
4.18 Low-Voltage Wiring—Liebert XDV Smart Modules .....	97
<b>5 Liebert XDC and Liebert XDP .....</b>	<b>99</b>
5.1 Liebert XDC Standard Features .....	99
5.1.1 Liebert XDC Optional Features .....	99
5.2 Liebert XDP Standard Features .....	109
<b>6 Heat Rejection .....</b>	<b>117</b>
6.1 Liebert Lee-Temp™ Refrigerant Control Air-cooled Condensers .....	117

6.1.1 Liebert Lee-Temp Refrigerant Control Air-Cooled Condenser .....	117
6.1.2 Standard Features-All Condensers .....	117
6.1.3 Condenser Coil .....	118
6.1.4 Housing .....	118
6.1.5 Propeller Fan .....	118
6.1.6 Fan Motor .....	118
6.1.7 Electrical Controls .....	118
6.2 Mechanical Considerations .....	119
6.2.1 Dimensions .....	119
6.3 Heat Rejection Piping .....	123
6.3.1 Piping for Direct Expansion (DX) Circuit—R-407C Air-Cooled Units .....	123
6.4 Install Double Discharge Risers .....	123
6.4.1 Air-Cooled Condenser with Liebert Lee-Temp “Flooded Condenser” Head Pressure Control System—R-407C (DX) Circuit .....	133
6.5 Calculating Refrigerant Volume .....	133
6.5.1 Liebert XDC DX R-407c Circuit Volume .....	134
6.6 Liebert Drycoolers .....	135
6.6.1 Liebert Drycooler Fan Cycling Control .....	135
6.6.2 Pump Controls .....	135
6.7 Typical System configurations .....	135
6.8 Site Considerations .....	136
6.9 Dimensions and Weights .....	137
6.10 Mounting the Drycooler .....	140
6.11 Glycol Piping .....	140
6.11.1 Piping Guidelines .....	140
6.11.2 Expansion Tanks, Fluid Relief Valves, Air Management and Other Devices .....	141
6.12 Electrical Supply .....	141
6.12.1 Line Voltage Wiring .....	142
6.12.2 Low Voltage Control Wiring .....	143
6.13 Filling Instructions .....	145
6.13.1 Preparing the System for Filling .....	145
6.13.2 Glycol Solutions .....	145
6.13.3 Filling the System .....	147
6.14 Outdoor Control Enclosure .....	147
6.14.1 Electrical Connections .....	149
6.14.2 Hazardous Voltage Power Supply Wiring .....	149
6.14.3 Extra-Low Voltage Control Wiring .....	150
6.14.4 Dual Pump Package Flow Switch .....	151
6.14.5 Dual Pump Controls Sequence of Operation .....	151
<b>7 Liebert iCOM .....</b>	<b>153</b>
7.1 Liebert iCOM Display Layout .....	153
7.2 Cooling Module Overview .....	155
7.3 Graphical Data Record .....	156

---

7.3.1 Liebert iCOM User Menu Icons and Legend .....	156
7.3.2 Liebert iCOM Service Menu Icons and Legend .....	157
7.4 Liebert XDC Alarms Descriptions .....	157
7.5 Warning Descriptions .....	161
7.6 Liebert XDP Alarms .....	161
7.7 Liebert XDP Warnings .....	164
7.8 CANbus Communications .....	164
7.9 Network Layout Options .....	165
7.9.1 Remote Temperature/Humidity Sensor Placement and Connection to the CANbus .....	165
7.9.2 CANbus Maximum Length .....	168
7.10 CANbus Cables .....	168
7.11 Connecting the CANbus Network .....	169
7.11.1 Connection to the Liebert XDP or Liebert XDC .....	169
7.11.2 Connecting to the Liebert XDV Smart Modules .....	171
7.11.3 Connecting to the Liebert XDH Smart Modules .....	172
7.11.4 Connecting to the Liebert XD Smart modules .....	175
7.12 CANbus Termination .....	175
7.12.1 Remote Temperature and Humidity Sensors Termination .....	175
7.12.2 Terminating a Smart Module .....	176
<b>8 Monitoring .....</b>	<b>177</b>
<b>9 Specifications and Model Number Nomenclature .....</b>	<b>183</b>

# 1 SYSTEM DESCRIPTION

The Liebert XD™ family of cooling units delivers efficient, sensible cooling to high-heat environments. Liebert XD systems are designed to cool computer racks and hot zones in a data center or computer room without taking up expensive floor space for cooling components.

The Liebert XD family includes:

- **Liebert XDC™**—Liebert XD Chiller; cools and pumps refrigerant to cooling modules
- **Liebert XDP™**—Liebert XD Pumping unit; pumps refrigerant to cooling modules
- **Liebert XDA™**—mounts on the rear of the equipment cabinet
- **Liebert XDCF™**—Liebert XD CoolFrame; mounts on the rear of an Egenera BladeFrame EX cabinet
- **Liebert XDH™**—Liebert XD Horizontal row cooler; integrated into hot aisle-cool aisle room layout
- **Liebert XDO™**—Liebert XD Overhead module; suspended from the ceiling structure
- **Liebert XDR™**—Liebert XD Rear cooling module; mounts on the rear of equipment cabinets that are 24" (600mm) wide and 42U high, approximately 79" (2000 mm)
- **Liebert XDV™**—Liebert XD Vertical module; mounted on top of the equipment cabinet or suspended from the ceiling structure

Systems combining Liebert XDO, Liebert XDR and Liebert XDV modules can remove more than 20kW (5.7 tons) of heat per cabinet. A set of Liebert XDCF modules also can remove 20kW (5.7 tons) of heat from an Egenera BladeFrame EX™ cabinet. A system with Liebert XDH modules can remove more than 30kW (8.5tons) of heat per rack.

For minimum Liebert XDP and Liebert XDC load recommendations, see [Liebert XDP Minimum Load](#) on page 16; [Liebert XDC Minimum Load](#) on page 15; and Table 9.13 on page 193 and Table 9.17 on page 197.

The Liebert XD system also performs at high efficiency rates. Properly spaced cooling modules and the Liebert XD system's fluid phase change technology, combine to reduce a Liebert XD system's energy consumption to at least 27 percent less than a traditional cooling system.

The Liebert XD family maintains this energy efficiency by employing the heat absorption properties of a liquid (pumped refrigerant) through a phase change. Refrigerant is pumped as a liquid, becomes a gas within the heat exchangers of the cooling modules (either the Liebert XDCF, Liebert XDH, Liebert XDO, Liebert XDR or Liebert XDV) and then is returned to either the Liebert XDP or Liebert XDC where it condenses to a liquid. This eliminates the compression cycle required by traditional systems. And, if a leak were to occur, the environmentally friendly refrigerant in the data center would escape as a gas, causing no harm to critical equipment. Because no compressor is used in the pumped refrigerant circuit, no oil is needed.

Liebert XD cooling modules further increase efficiency with optional control board that reduces fan use when maximum cooling levels are not required. The control board is available on Liebert XDH, Liebert XDO and Liebert XDV modules.

## 1.1 European Union Fluorinated Greenhouse Gas Requirements

Stationary air conditioning, refrigeration, heat pump equipment and stationary fire protection systems in the European Community market and operating with fluorinated greenhouse gases (f-gas), such as R407C, R134a, R410A, must comply with the F-Gas Regulation: (EC) No. 842/2006 (F-gas). The regulation prohibits, among other actions, venting fluorinated greenhouse gases to the atmosphere.

The F-Gas Regulation requires operators to use all measures that are technically feasible and do not entail disproportionate cost to prevent leakage of these gases, to test for leakage regularly and to recover f-gas before disposing of equipment, as well as during service and maintenance.

Refer to the full regulation for additional details.

## 1.2 Generic Piping Layouts

Liebert XD systems are available in two configurations—differentiated essentially by the method of heat rejection (see Figure 1.1 below and Figure 1.2 below). The Liebert XDP is a pumping unit connected to a building chilled water system to control and circulate the refrigerant. Liebert XDPs pump refrigerant to Liebert XDCF, Liebert XDH, Liebert XDO, Liebert XDR or Liebert XDV modules, isolate refrigerant circuit from building chilled water supply with an internal heat exchanger and maintains refrigerant temperature above the actual dew point. The Liebert XDC incorporates the pumping functions with the chiller, which must be connected to a separate heat rejection system. Pumping and refrigerant control are performed by Liebert XDC.

Figure 1.1 Liebert XDP generic piping layout

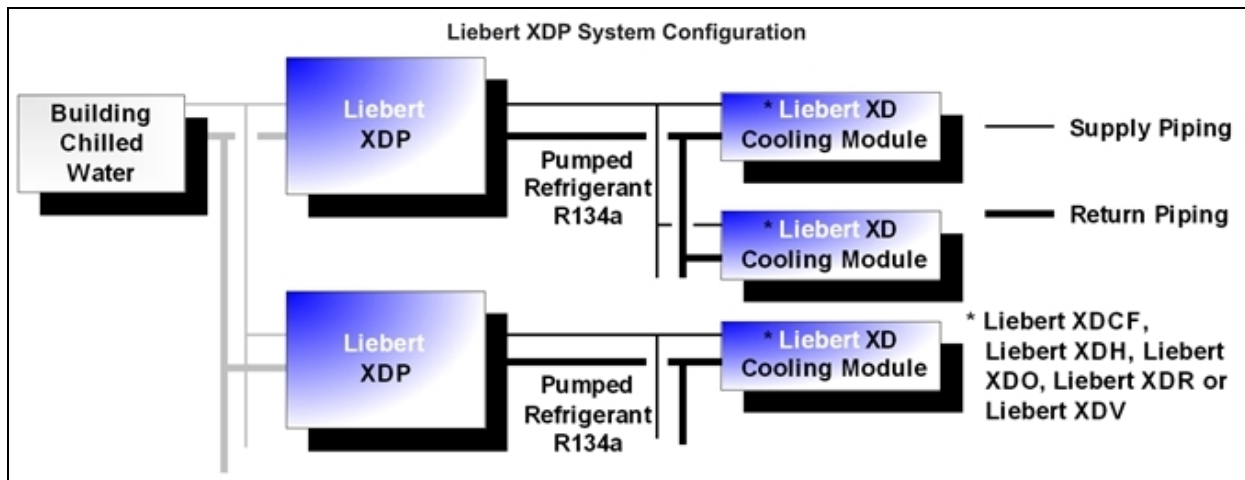
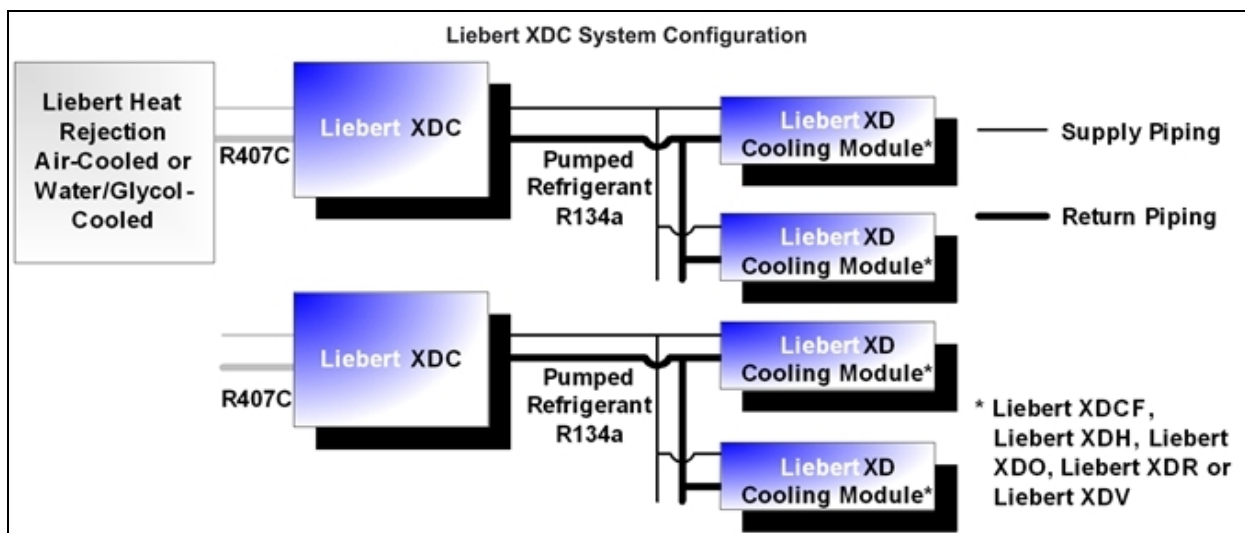

Figure 1.2 Liebert XDC generic piping layout



### 1.3 Liebert XDA—Air Flow Enhancer

The Liebert XDA is a fan unit that boosts the airflow through densely populated enclosures, removing hot spots from within the racks. One or two units can be mounted on the rear of most rack enclosures.

**Figure 1.3** Liebert XDA—air flow enhancer—on equipment enclosure



## 1.4 Liebert XDCF—Liebert XD CoolFrame

The Liebert XDCF is a self-contained module designed to cool Egenera’s BladeFrame EX cabinets and equipment without exhausting heat into the room. Two modules (top and bottom) may be mounted on the rear of a BladeFrame cabinet. Liebert XDCF modules consist of a sheet-metal frame, coil and filter dryer. It has no moving parts and needs no electricity.

The module is available with optional, Liebert XD Flex Pipes (flexible metal pipes) with quick-connect couplings at each end for easy connection to the refrigerant distribution pipes.

**Figure 1.4** Liebert XDCF modules on Egenera’s BladeFrame EX cabinets



## 1.5 Liebert XDH—Horizontal Cooling Module

The Liebert XDH is designed for placement within a row of computer cabinets in the data center in a hot-aisle-cold-aisle arrangement to maximize the Liebert XDH’s cooling. The Liebert XDH, available in a half-rack-width module (12" [305mm]), is intended for use with a Liebert XD pumped refrigerant cooling system, supplied by either a Liebert XDP or Liebert XDC. The module takes in hot air through the rear from the hot aisle, cools the air by air-to-fluid heat exchangers and discharges the air through the front of the module into the cold aisle in a diffuse pattern. The cooling air is then drawn into the enclosures to cool the equipment.



Replaceable front panels on the Liebert XDH may be customized to match the appearance of various computer manufacturer's equipment, allowing the Liebert XDH to blend in with adjacent server equipment and enclosures. Unidirectional and bidirectional diffusers are available to direct cooling air for more efficient cooling, depending on the Liebert XDH's positioning in a row or at the end of a row. Chilled R-134a refrigerant is provided to the Liebert XDH by a Liebert XDP or by a Liebert XDC. The Liebert XDH has dual refrigeration circuits, one in the upper half of the module and the other in the lower half. This permits increasing and decreasing cooling levels in response to server room conditions. The dual refrigeration circuits permits interlaced connection of two Liebert XD refrigerant sources to enhance system reliability. The Liebert XDH may be installed in a Liebert XD piping system that includes other Liebert XD cooling modules.

Controls on the front of the Liebert XDH permit independent operation of the two banks of fans. Dual power connections ensure continued fan operation if one of two electrical sources fails. Optional smart modules allow remote shutdown, fan failure alarms, condensate detection and switching fan per bank On and Off. This saves energy by permitting the module to run with two fans per bank and switching on the middle when the temperature requires all fans for cooling.

The Liebert XDH is available for hard-piped configurations and with flexible metal pipes with quick-connect couplings (one-shot or removable) at each end for easy connection to the header system. The Liebert XDH and Liebert XD Flex Pipes are also available for shipment with a pre-charge of R134a. This option requires the use of the one-shot flexible pipes.

**Figure 1.5 Liebert XDH—horizontal cooling module in hot aisle-cold aisle arrangement**

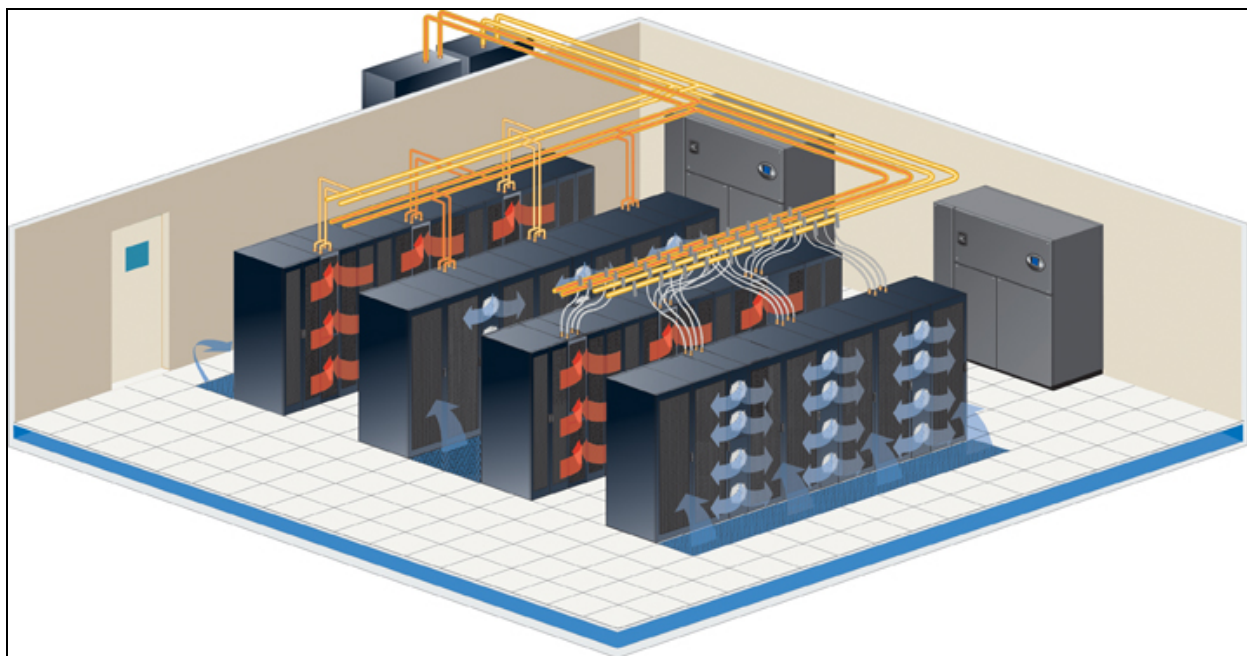

## 1.6 Liebert XDO—Overhead Cooling Module

The Liebert XDO is an overhead cooling system designed for installation above heat-dissipating equipment. A fan draws hot air exhausted from the equipment through two cooling coils and discharges cool air back down to the equipment (see Figure 1.6 on the next page).

A Liebert XDO smart module will allow remote monitoring, shutdown, fan failure alarms, condensate detection and automatically cycling the fan On and Off as the heat load requires. The Liebert XDP/Liebert XDC monitors room conditions and prevents coil condensation by maintaining the temperature of the refrigerant pumped to the Liebert XDOs above the room dew point.

The Liebert XDO is available for hard-piped configurations or with Liebert XD Flex Pipes with quick-connect couplings (one-shot) for easy connection to the header system. When the pre-charged option is selected, the Liebert XDO and the one-shot flexible pipes contain R134a.

**NOTE: The Liebert XDO is the most sensitive module to system load. The Liebert XDO's air intake and the discharge are not separated by a rack. This can lead to the Liebert XDO pulling in cold air rather than hot air. The Liebert XDP and Liebert XDC minimum loads must be met to prevent this from occurring.**

Figure 1.6 Suspended Liebert XDO modules in hot aisle-cold aisle arrangement

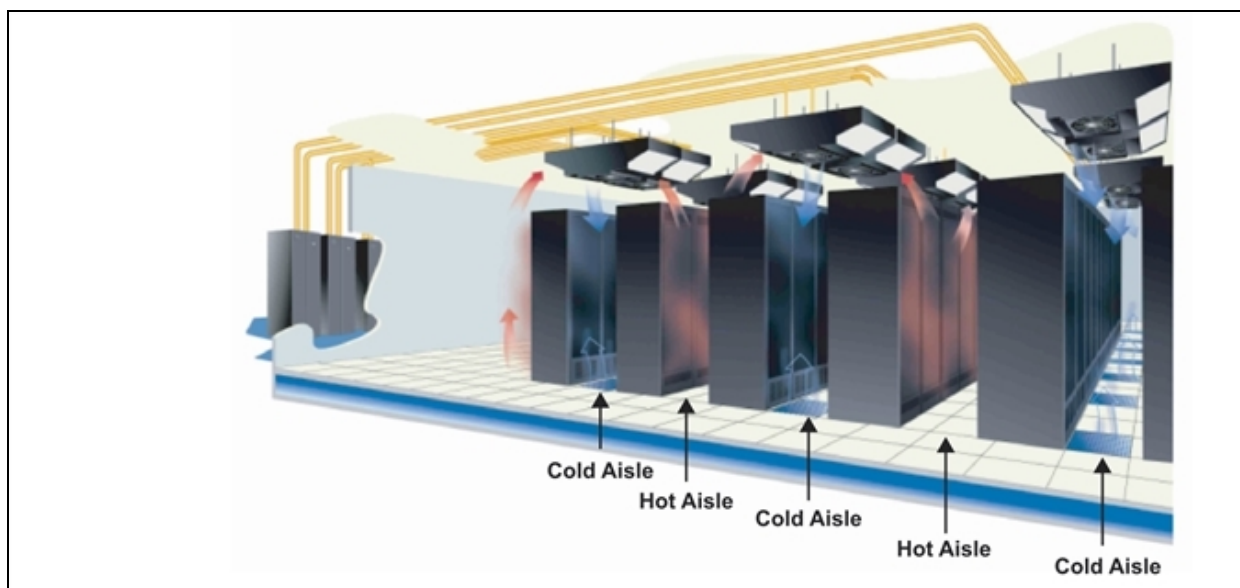

## 1.7 Liebert XDR—Rear Cooling Module

The Liebert XDR is a cooling system for high-density heat loads that mounts on the rear of a 24" (600mm) x 42U rack (consult the factory for other rack sizes) and maintains access to the back of the server rack. Room air is drawn in through the front of the rack and picks up heat from the servers. The coil captures that heat, cooling the air, which is expelled through the rear of the rack.

The Liebert XDR relies on the rack equipment's fans to move air across the microchannel coil. Captured heat is carried away through pumped R-134a refrigerant supplied by either a Liebert XDP or Liebert XDC.

The Liebert XDR is available in hard-piped configurations or with Liebert XD Flex Pipes with quick-connect couplings (one-shot or removable) for easy connection to the header system. The Liebert XDR and flexible pipes are also available pre-charged with R134a refrigerant. This option requires the one-shot connections.

**Figure 1.7 Liebert XDR on cabinet**



## 1.8 Liebert XDV—Vertical, Above-Cabinet Cooling Module

The Liebert XDV cooling system is designed to be attached to the top of a computer cabinet or rack containing heat-dissipating equipment. Two fans draw hot air exhausted from the equipment or from the hot aisle, pass it through a cooling coil and discharge cool air back down to the cold aisle, where the equipment's air intake is located.

The Liebert XDV comes from the factory ready to draw heated air through a perforated grille on the back of the module. The Liebert XDV is easily modified to draw hot air through the bottom of the module, should that cooling method be better suited to your application.

Liebert XDV smart modules allow remote shutdown, fan failure alarms and automatically switching the second fan On and Off. This saves energy by permitting the module to run with one fan and switching on a second fan when the temperature requires both fans for cooling.

The Liebert XDV is available for hard-piped configurations or with Liebert XD Flex Pipes with quick-connect couplings (one-shot or removable) for easy connection to the header system. The Liebert XDV and flexible pipes are also available for shipment with a pre-charge of R134a. This option requires the use of the one-shot flexible pipes

**Figure 1.8 Top-mounted Liebert XDV modules with hard piping in hot aisle-cold aisle arrangement**

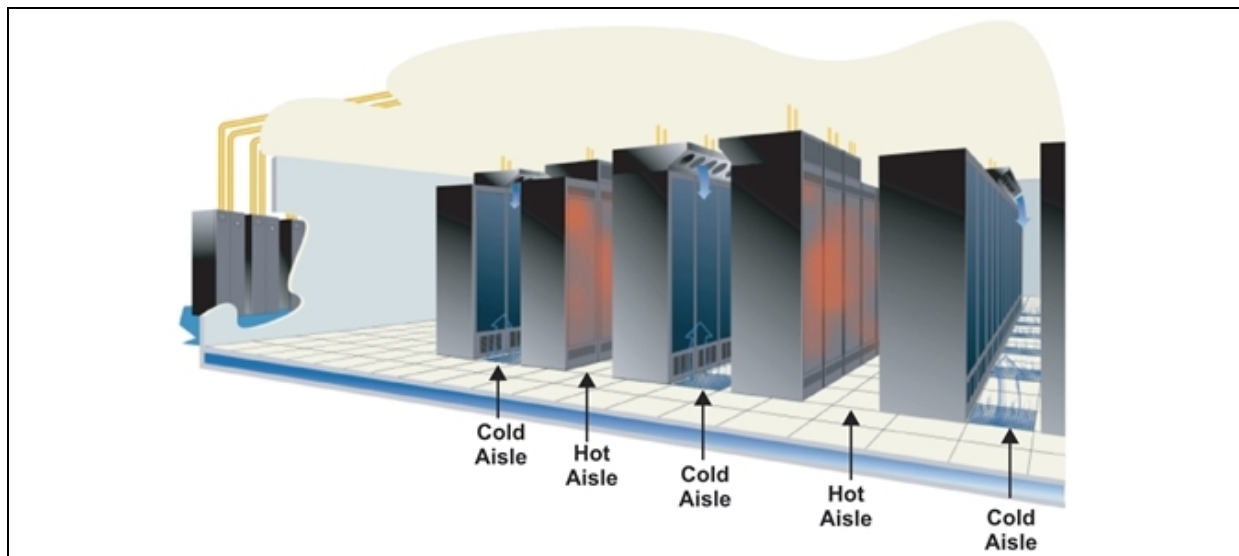

**Figure 1.9 Top-mounted Liebert XDV modules with Liebert Flex Pipe in hot aisle-cold aisle arrangement**

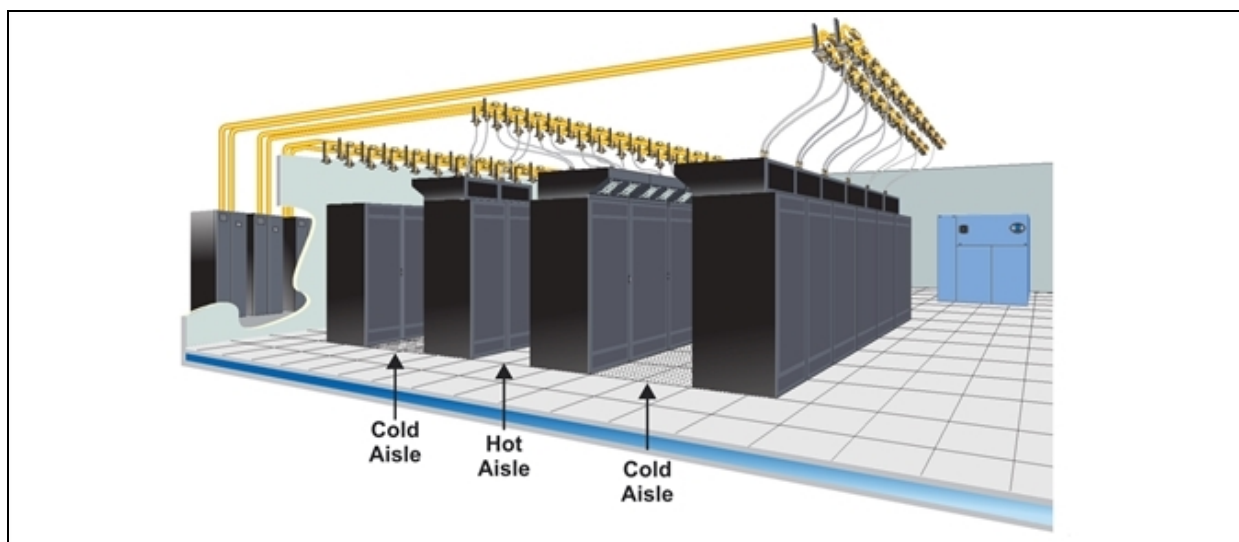

## 1.9 Liebert XDC—Refrigerant Chiller

The Liebert XDC is an indoor chiller that connects directly to the Liebert XD cooling modules and provides refrigerant circulation and control. The Liebert XDC keeps the refrigerant temperature above the room dew point at the sensors. The Liebert XDC contains a refrigerant to refrigerant heat exchanger along with two tandem scroll compressor circuits. This allows heat rejection to the outdoor ambient air by using either the air-cooled condensers or water/glycol shell-and-tube condensers much like a standard computer room air conditioning unit. The Liebert XDC employs two remote sensors (for redundancy) to determine the temperature and humidity in the air and instantly adjusts refrigerant supply temperature to compensate for changing conditions.

The Liebert XDC uses the Liebert iCOM®. This advanced control enables the user to monitor essentially all aspects of the Liebert XD Precision Cooling system, from operating status to maintenance

### 1.9.1 Liebert XDC Minimum Load

The Liebert XDC's minimum recommended operating load is 40% of system nominal capacity. For example, a Liebert XDC160 60Hz system's minimum load would be 64 kW. Loading below this value can unfavorably affect system operation.

**Figure 1.10 Liebert XD Chiller**



## 1.10 Liebert XDP—Pumping Unit

The Liebert XDP isolates the building's chilled water circuit from the pumped refrigerant circuit. The Liebert XDP circulates refrigerant to Liebert XD cooling modules while preventing condensation by maintaining the refrigerant's temperature above the room dew point at the sensors. The Liebert XDP employs two sets (for redundancy) of remote sensors to determine the temperature and humidity in the air and instantly adjusts refrigerant supply temperature to compensate for changing conditions.

The Liebert XDP uses the Liebert iCOM. This advanced control enables the user to monitor essentially all aspects of the Liebert XD Precision Cooling system, from operating status to maintenance.

### 1.10.1 Liebert XDP Minimum Load

The Liebert XDP's minimum recommended operating load is 30% of system nominal capacity. For example, a Liebert XDP160 60Hz system's minimum load would be 48 kW. Loading below this value can unfavorably affect system operation.

**Figure 1.11 Liebert XDP**



## 1.11 Liebert XD Piping

Liebert XD Piping is prefabricated distribution piping that is installed in anticipation of a growing system. Liebert XD cooling modules are added as required and are quickly made operational with flexible connection piping with threaded couplings. This unique system allows the room cooling capacity to increase to more than 30kW per rack with no additional disruptive piping installation. The flexible connection piping also allows the cooling modules to be re-positioned without interruption in operation.

### 1.11.1 Liebert XD Field Piping

#### Flexible Piping Kit

Flex pipe kits are available in lengths of 4, 6, 8 and 10 feet (1.2, 1.8, 2.4 and 3 meters). Connection style to the module end may be straight or 90 degrees with one-shot style couplings or removable couplings. The one-shot flexible pipes are charged at the factory with R134a. Connection to the prefabricated piping assembly is a threaded coupler. For information on acquiring the correct kit for your installation refer to DPN000780, available by calling 1-800-222-5877 and from your local Vertiv representative. Contact the factory when ordering additional flex piping kits for Liebert XD systems installed before 2007.

#### Prefabricated Headers

Field piping kits are available in several versions

- 10 ft. (3.05m) with 5 or 10 ports
- 8 ft. (2.44m) with 2 or 4 ports

Each version is available in two pipe sizes:

- Supply pipe: 1-1/8"; return pipe: 2-1/8"
- Supply pipe: 1-3/8"; return pipe: 2-5/8"

Each kit contains one (1) supply pipe and one (1) return pipe. Each port has a threaded coupling at the end with automatic shutoff when disconnected. Each port also has a ball valve for manual shutoff. For more information refer to section [Liebert XD Piping System Design](#) on page 38.

### Liebert XD Connection Port Kit

The connection ports in the Liebert XD Field Piping Kits are available as Liebert XD Connection Port Kit. Each port has a threaded coupling, with automatic shutoff when disconnected, at the end. Each port also has a ball valve for manual shutoff. Each kit contains one supply and one return port. Two kit sizes are available:

- Supply pipe: 1-1/8"; return pipe: 2-1/8"
- Supply pipe: 1-3/8"; return pipe: 2-5/8"

**Figure 1.12 Liebert XD connection port kit**

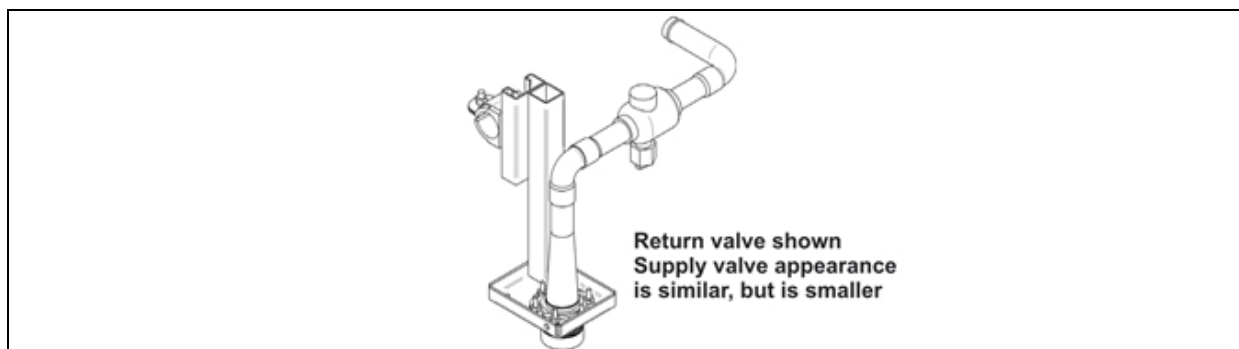

**Table 1.1 Liebert XD field-installed port kits header connection size**

Assembly P#	Supply Header Diameter	Return Header Diameter
183169G3	1-1/8"	2-1/8"
183169G4	1-3/8"	2-5/8"

This page intentionally left blank.



## 2 STARTING A NEW EQUIPMENT COOLING PROJECT

### 2.1 Determining Cooling Equipment Needs

1.	Is adequate space available for a Liebert XD installation?	_____
2.	Is the hot aisle/cold aisle approach being utilized for this room design or can it be utilized in this room design?	_____
3.	Is redundant cooling equipment required?	_____
4.	Are there access considerations for all components (possible rigging problems)?	_____
5.	What heat load growth is anticipated over the next few years?	_____
6.	How are the cabinets going to be populated (density of heat generation)?	_____
7.	What monitoring requirements are desired or needed?	_____
8.	Who will be involved in this project (stakeholders)?	_____
9.	Is there existing computer room environmental cooling systems for humidity control and filtration?	_____
10.	Is the vapor barrier sufficient?	_____
11.	Is a chilled water system available?	_____
	• What is the system's capacity?	_____
	• What is the system's chilled water supply temperature?	_____
	• Does the chilled water supply temperature vary during the year or is the temperature constant?	_____
12.	How much power is available for cooling equipment?	_____
13.	What is the maximum distance between the Liebert XDP/Liebert XDC unit and the farthest Liebert XD cooling module in the proposed layout?	_____
14.	If an air-cooled Liebert XDC is used—is an area available for the remote condenser?	_____
15.	Does the Liebert XD system refrigerant volume exceed 13 lb/1000ft <sup>3</sup> ? If so, a refrigerant detection and removal equipment may be required. Refer to <a href="#">Liebert XD Refrigerant</a> on page 55.	_____

### 2.2 Implementing a Hot-Aisle/Cold Aisle Design

A best practice is to place equipment racks in alternating rows of cold aisles and hot aisles. This is best accomplished when the layout of the file-server farm area is being planned. It is more difficult to accomplish when the computer room is already populated with operating hardware.

In the cold aisle, the equipment racks are arranged face-to-face so the cooling air from the computer room cooling unit discharged up through the perforated floor tiles is drawn into the face of the computer hardware and exhausted out the back of the equipment rack into the adjacent hot aisles.

Hot aisles are literally hot because the objective of the alternating cold and hot aisle design is to separate the source of cooling air from hot air discharge, which returns to the computer-room cooling unit. Therefore, no perforated tiles should be placed in the hot aisles. This would mix hot and cold air, lowering the temperature of the air returning to the cooling units, reducing their usable capacity.

This page intentionally left blank.

## 3 DESIGNING A LIEBERT XD SOLUTION

Liebert XD systems are intended for use with precision air conditioning equipment, such as the Liebert Deluxe System/3 and Liebert DS™. The precision air conditioning equipment is required for the humidification and filtration of the room air.

The Liebert XD systems provide efficient, highly effective heat removal (sensible cooling only), without providing humidity control. The Liebert XD control system maintains the refrigerant temperature just above the dew point of the space to prevent condensation. Since the capacity of the system is limited by the dew point in the space, sufficient dehumidification and an adequate vapor barrier must be provided to maintain the dew point at or below the level necessary to achieve the required capacity.

The Liebert XD system is optimized for hot aisle/cold aisle equipment configurations, an industry best practice for dealing with extremely high heat loads. Room and equipment designs that preclude the hot aisle/cold aisle configuration are often well-suited to cooling with the Liebert XDR system.

Refer to the technical data manual of either the Deluxe System/3 (SL-18100) or the Liebert DS (SL-18827) for additional installation and application guidelines that apply to all critical space cooling applications.

### 3.1 Determine Cooling Requirements and Select Liebert XD System

1. Calculate the total cooling required
2. Determine placement of the Liebert XD modules
3. Determine required pipe sizes
4. Calculate the refrigerant volume of the Liebert XD systems
5. Complete design details including, electrical, mounting, piping, etc.

### 3.2 Calculate the Heat Load to be Handled by Liebert XD System

When designing a cooling solution using the Liebert XD system, the initial steps are similar to those required to cool a conventional critical space. The total heat load must be calculated, including sensible and latent cooling requirements. These should be increased by the reserve capacity needed for pull-down situations where the room temperature must be reduced and to provide for unexpected increases in heat load.

**NOTE: Reserve capacity is distinct from redundant capacity in that redundant capacity may or may not be available concurrently with normal operating capacity. Reserve capacity is available concurrently with normal operating capacity.**

The next step is to determine how much of the required cooling capacity is to be provided by Liebert Deluxe™ or Liebert DS units. If the facility is new, typically up to 150W/ft<sup>2</sup> (1500W/m<sup>2</sup>) of cooling can be obtained from Liebert precision air conditioning units supplying air through a raised floor. In existing facilities, such factors as raised floor height, under-floor obstructions or other limitations may reduce this to less than 50W/ft<sup>2</sup> (500W/m<sup>2</sup>).

Once the total required sensible cooling capacity is known, subtract the sensible cooling portion to be provided by Liebert Deluxe or Liebert DS units. This yields the cooling capacity to be provided by the Liebert XD system. Confirm the minimum heat load for the Liebert XDP/Liebert XDC is still present in the data center (48kW and 64kW respectively).

## Example

For example, a 2000 ft<sup>2</sup> server room with has 30 racks, 15 racks produce 20kW of heat each and 15 produce 10kW of heat per rack.

1. Calculate the total sensible cooling load.

$$15 \text{ racks} \times 20\text{kW}/\text{rack} = 300\text{kW}$$

$$15 \text{ racks} \times 10\text{kW}/\text{rack} = 150\text{kW}$$

$$300\text{kW} + 150\text{kW} = 450\text{kW}$$

The total room load is 450kW.

2. Check heat density per square foot:

$$450\text{kW}/2000\text{ft}^2 = 0.225\text{kW}/\text{ft}^2 = 225\text{W}/\text{ft}^2$$

3. Determine base cooling requirements:

Typically, perimeter cooling accounts for 2 to 5kW per rack.

$$2\text{kW} \times 30 \text{ racks} = 60\text{kW}$$

Based on 2kW/rack, 60 kW will be handled by the perimeter cooling.

4. Determine Liebert XD cooling requirements:

$$450\text{kW} - 60\text{kW} = 390\text{kW}$$

Three Liebert XDP160s would be needed.

5. Calculate the Liebert XDP reserve capacity:

$$390\text{kW}/3 \text{ Liebert XDP160s} = 130\text{kW}$$

Each Liebert XDP, on average, would bear 130kW of the heat load.

$$130\text{kW} / 160\text{kW} = 81\% \text{ of maximum load}$$

This Liebert XD solution has 19% reserve capacity.

### 3.3 Selecting Liebert XD Cooling Modules

The next step is to select the Liebert XD cooling modules to be configured into the solution. Liebert XD modules that use pumped refrigerant can be connected to the same Liebert XDP/Liebert XDC piping circuit. This includes the Liebert XDCF, Liebert XDH, Liebert XDO, Liebert XDR and Liebert XDV.

Generally, the Liebert XDO is selected for use in new installations or renovations where the module can be installed on the ceiling or in the overhead space.

The Liebert XDV is designed to permit mounting directly on top of an equipment cabinet, for ease of installation in existing facilities. The Liebert XDV may also be suspended from overhead, using suitable mounting methods.

The Liebert XDCF is a self-contained module designed to cool Egenera's BladeFrame EX cabinets and equipment without exhausting heat into the room. Two modules may be mounted on the rear of a BladeFrame cabinet.

The Liebert XDH is installed among equipment cabinets and is particularly suited for new installations. The Liebert XDR replaces the rear door of an equipment cabinet.

## Example

Continuing the preceding data center example (in [Calculate the Heat Load to be Handled by Liebert XD System](#) on page 21) of a server room 2000 ft<sup>2</sup> with 30 racks (15 producing 20kW of heat per rack and 15 producing 10 kW of heat per rack), the three Liebert XDPs required can supply coolant to various types of Liebert XD modules. For instance, the racks with 20kW per rack could be cooled with either Liebert XDH20, Liebert XDO20 or Liebert XDR20. The racks with 10kW per rack could be cooled using the Liebert XDV10.

1. For the 15 racks with 20kW of heat each, the total load is:

$$15 \text{ racks} \times 20\text{kW per rack} = 300\text{kW}$$

The perimeter cooling will address the first 2-5kW per rack:

$$2\text{kW} \times 15 \text{ racks} = 30\text{kW}$$

The Liebert XD solution would have to remove 270kW for these racks with higher heat load.

$$300\text{kW} - 30\text{kW} = 270\text{kW}$$

Module	Conditions °F (°C)	Capacity at Conditions, kW	Load, kW	Modules Required
Liebert XDH20	98 (36.6)	22.0	270	13
Liebert XDO20	98 (36.6)	22.5	270	12
Liebert XDR20	98 (36.6)	22.0	270	15

2. For the 15 racks with 10kW of heat each, the total load is:

$$15 \text{ racks} \times 10\text{kW per rack} = 150\text{kW}$$

The base cooling will address the first 2-5kW/rack:

$$2\text{kW} \times 15 \text{ racks} = 30\text{kW}$$

The Liebert XD solution would have to remove 120kW for these racks with a higher heat load.

$$150\text{kW} - 30\text{kW} = 120\text{kW}$$

Module	Conditions °F (°C)	Capacity at Conditions, kW	Load, kW	Modules Required
Liebert XDV10	98 (36.6)	10.0	120	12

3. For this data center example, the Liebert XD solution would consist of:

- 3 Liebert XDP160s
- 12 Liebert XDV10s

and any of the following:

- 13 Liebert XDH20s
- 12 Liebert XDO20s
- 15 Liebert XDR20s

### 3.4 Configuring a Liebert XD System

#### 3.4.1 Number of Modules Supported by a Liebert XDP or Liebert XDC

The numerals designating the model size of a Liebert XD module may be used to configure a cooling system. For example, a Liebert XDO20 has a model size of 20 and a Liebert XDP160 will accommodate cooling modules with a cumulative model size of 160.

Similarly, the minimum number of modules connected to a Liebert XDP or Liebert XDC may be calculated using the model size number for the Liebert XDP or Liebert XDC and the modules. See Table 3.1 below.

**Table 3.1 Maximum and minimum modules supported by a Liebert XDP or Liebert XDC**

Cooling Module Type	Liebert XDC		Liebert XDP	
	Max	Min	Max	Min
Liebert XDCF10	16	6	16	5
Liebert XDH20	8	4	8	3
Liebert XDH32	5	2	5	2
Liebert XDO16	10	4	10	3
Liebert XDO20	8	4	8	3
Liebert XDR20	8	4	8	3
Liebert XDV8	20	8	20	6
Liebert XDV10	16	7	16	5

Different types of Liebert XD cooling modules may be connected to the same Liebert XDP or Liebert XDC as long as the sum of their cooling capacity does not exceed the supporting Liebert XDP's or Liebert XDC's model size number.

#### Example

Continuing the example in [Selecting Liebert XD Cooling Modules](#) on page 22, the Liebert XD solution in that example consisted of:

- Three (3) Liebert XDPs and
- 12 Liebert XDV10s

and any of the following:

- 13 Liebert XDH20s
  - 12 Liebert XDO20s
  - 15 Liebert XDR20s
1. Using the Liebert XDH20 to continue with the example, the Liebert XD systems could be populated so that the modules were on dedicated Liebert XDPs.

**Table 3.2 Sample Liebert XD coolant supply loop connections**

Liebert XD Loop	Liebert XDH20	Liebert XDV10	Maximum Loop Load, kW
Liebert XDP 1	7 modules	0 modules	154
Liebert XDP 2	6 modules	0 modules	132
Liebert XDP 3	0 modules	12 module	120

2. Another possibility would be to mix the Liebert modules in a manner that allows each Liebert XDP to have similar loads.

**Table 3.3 Sample Liebert XD coolant supply loop connections, balanced loads**

Liebert XD Loop	Liebert XDH20	Liebert XDV10	Applied System Load, kW*
Liebert XDP 1	4 modules	5 modules	138
Liebert XDP 2	4 modules	5 modules	138
Liebert XDP 3	5 modules	2 module	130

**NOTE:** An individual Liebert XDP160 or Liebert XDC160 can remove up to 160kW. The 160kW can be removed by the various modules whose individual capacities may vary based on the data center conditions, such as the entering air temperatures or entering refrigerant temperature. For the Liebert XD system examples above, additional modules may be added as heat loads increase until the 160kW maximum is reached. The Liebert XDP 3 in the example in Table 3.3 above, which has a load of 130kW, could accept modules that would remove 30kW: one Liebert XDH20 and one Liebert XDV10.

### 3.4.2 System Connection Configuration

If possible, connect the Liebert XD modules to Liebert XDPs or Liebert XDCs in an interlaced configuration (see Figure 3.1 on the next page). In an interlaced configuration, half the cooling modules in an aisle are connected to one Liebert XDP or Liebert XDC and the other half in that aisle are connected to another Liebert XDP or Liebert XDC. Interlacing the connection piping will keep half the Liebert XD modules operating and maintain cooling in the conditioned space should one of the Liebert XDP or Liebert XDC units fail.

Figure 3.1 Typical Liebert XDR piping—interlaced connections

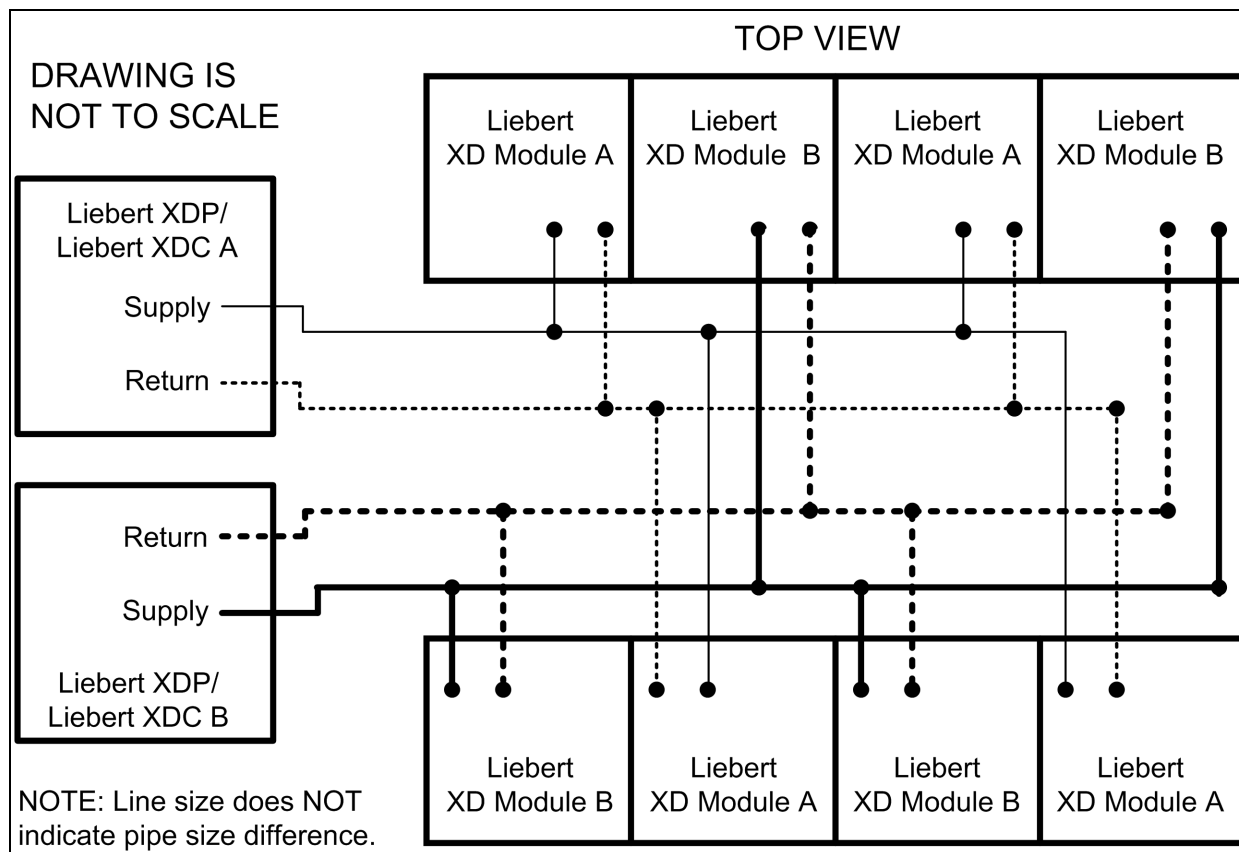

### 3.5 Airflow Requirements for Liebert XD Solutions

Computer manufacturers typically specify a temperature change from intake to exhaust (delta T) of 18-27°F (10-15°C) for the air passing through a rack enclosure. The heat generated by electronic equipment combined with the tight quarters of equipment cabinets mean high volumes of air must move through an enclosure to meet this cooling specification.

A Liebert XD system can supply the cold air to satisfy this cooling demand, but airflow through the enclosure must be adequate to extract the heat from the cabinet. Liebert’s XDA units can boost the airflow to levels necessary to protect critical equipment. The Liebert XDA is particularly suited to the hot aisle/cold aisle arrangement.

### 3.6 Liebert XDCF Placement

The Liebert XDCF is a self-contained module designed to cool Egenera’s BladeFrame EX cabinets and equipment. Liebert XDCF modules attach to the rear of the Egenera BladeFrame EX cabinet, beside the power modules (see Figure 3.2 on the facing page). No cutting or drilling is required to attach the modules; all mounting holes, slots and pins required are fabricated at the factory. The Liebert XDCF does not require electrical connections.

The number of Liebert XDCF modules required is determined by the heat load of the cabinet—cabinets cannot share cooling from a Liebert XDCF module.



The Egenera BladeFrame EX cabinet has provisions for mounting two Liebert XDCF modules, should the heat load require two modules. If only one Liebert XDCF will be needed, Liebert recommends using the lower Liebert XDCF module.

The complete system consists of Liebert XDCF modules, piping, Liebert XDP or Liebert XDC refrigerant distribution units and those units' chillers or drycoolers.

**Figure 3.2 Liebert XDCF module mounting locations**

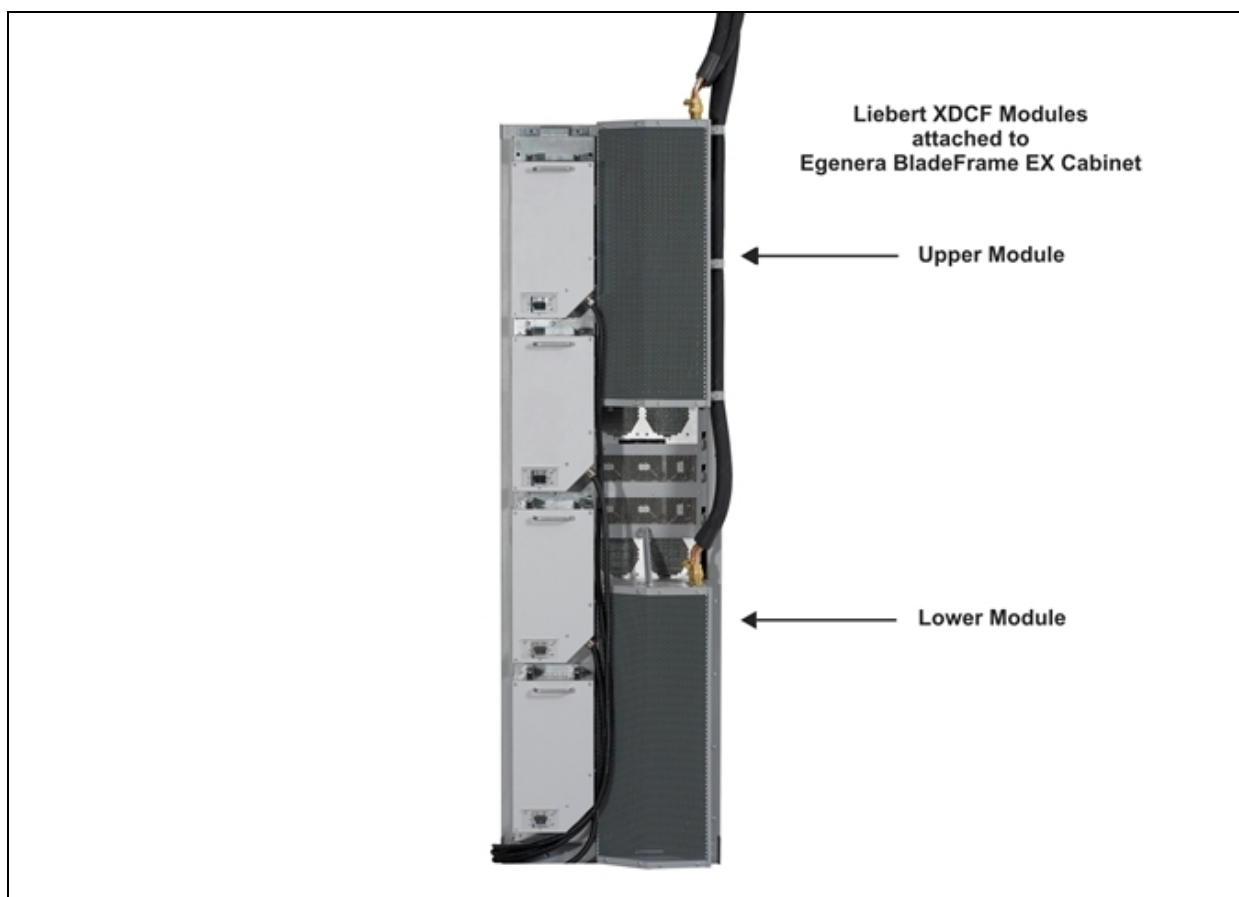

### 3.7 Liebert XDH Placement

The free-standing Liebert XDH cooling module is best placed among the equipment cabinets in a hot aisle-cold aisle arrangement (see Figure 3.3 on the next page). The Liebert XDH draws in air from the hot aisle, cools it and discharges the cooled air into the cold aisle where it is drawn into the equipment cabinets. Even spacing aids in optimizing cooling.

Liebert XDH modules should be placed among the cabinets that generate the greatest amount of heat. If heat loads are dispersed evenly throughout the room, the Liebert XDH modules may be spread out accordingly. Bi-directional air diffusers should be used on Liebert XDH modules installed between racks.

If a Liebert XDH is installed at the end of a row, uni-directional air diffusers should be used on that Liebert XDH. The uni-directional diffusers can be used for left or right air discharge by removing them from the Liebert XDH, turning them 180 degrees, then reattaching them to the Liebert XDH.

Figure 3.3 Liebert XDH placement (top view)

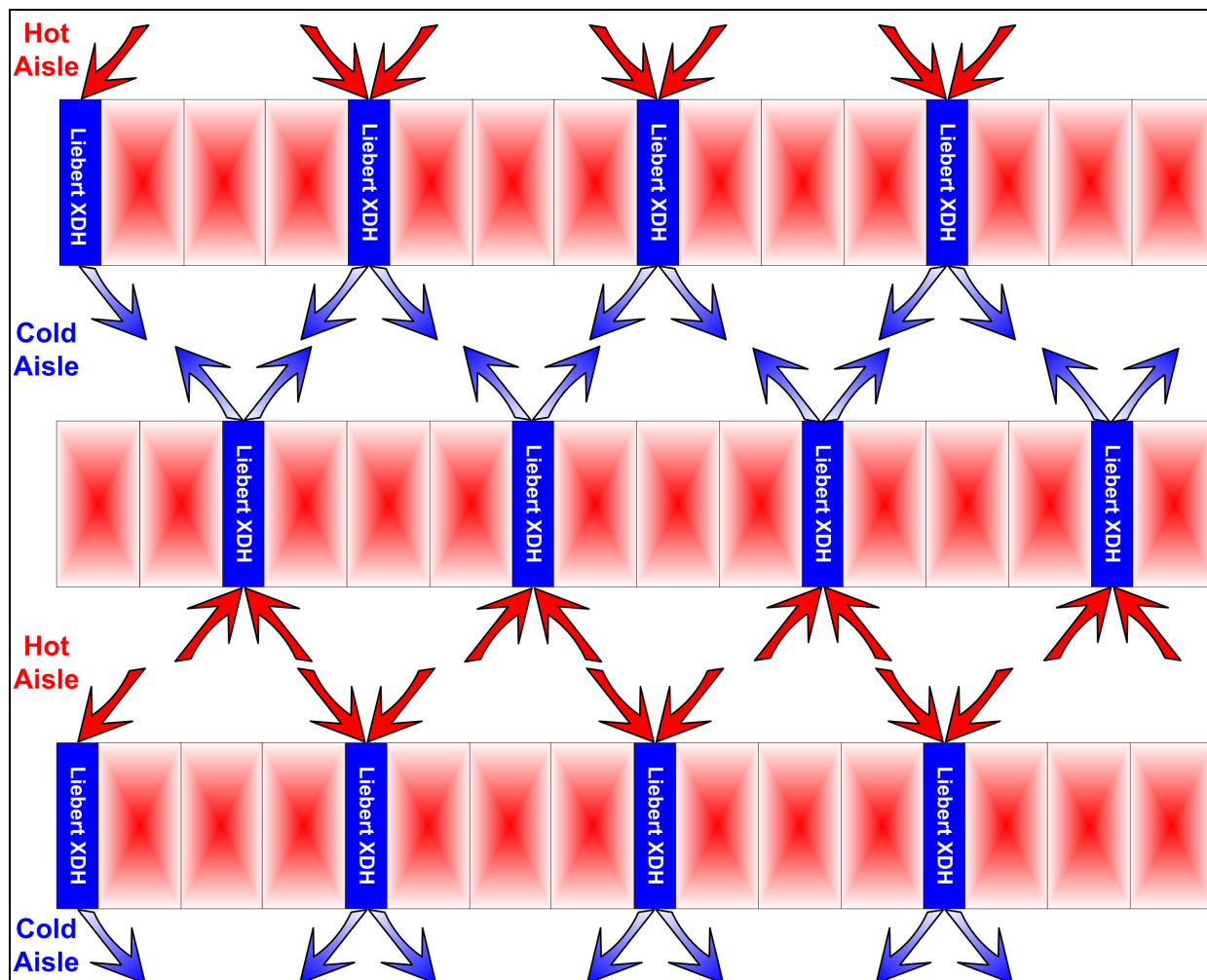

### 3.8 Liebert XDO Placement

#### 3.8.1 Determining Spacing of Liebert XDOs in an Aisle

Liebert XDO modules should be placed in rows directly above the cold aisles of a room for optimum cooling. Each Liebert XDO serves an area equal in width to the cold aisle spacing, typically 12 to 16 feet (3.7 to 4.9m). The length of the area served includes any space between Liebert XDO modules in a row. Depending on the cooling capacity to be achieved, spacing between Liebert XDO modules in a row may vary from zero to as much as 6 feet (1.8m). When the spacing increases to more than 6 feet (1.8m), overall performance of the system may be negatively affected and gaps in cooling may occur.

Install one Liebert XDO at the end of each aisle being cooled and to space the remainder between these end modules as shown in Figure 3.4 on the facing page. This layout will block the incursion of hot air around the side of the end cabinets. Allowing space between the Liebert XDO groups facilitates maintenance by allowing access to the overhead space.

Figure 3.4 Liebert XDO spacing—horizontal (side view)

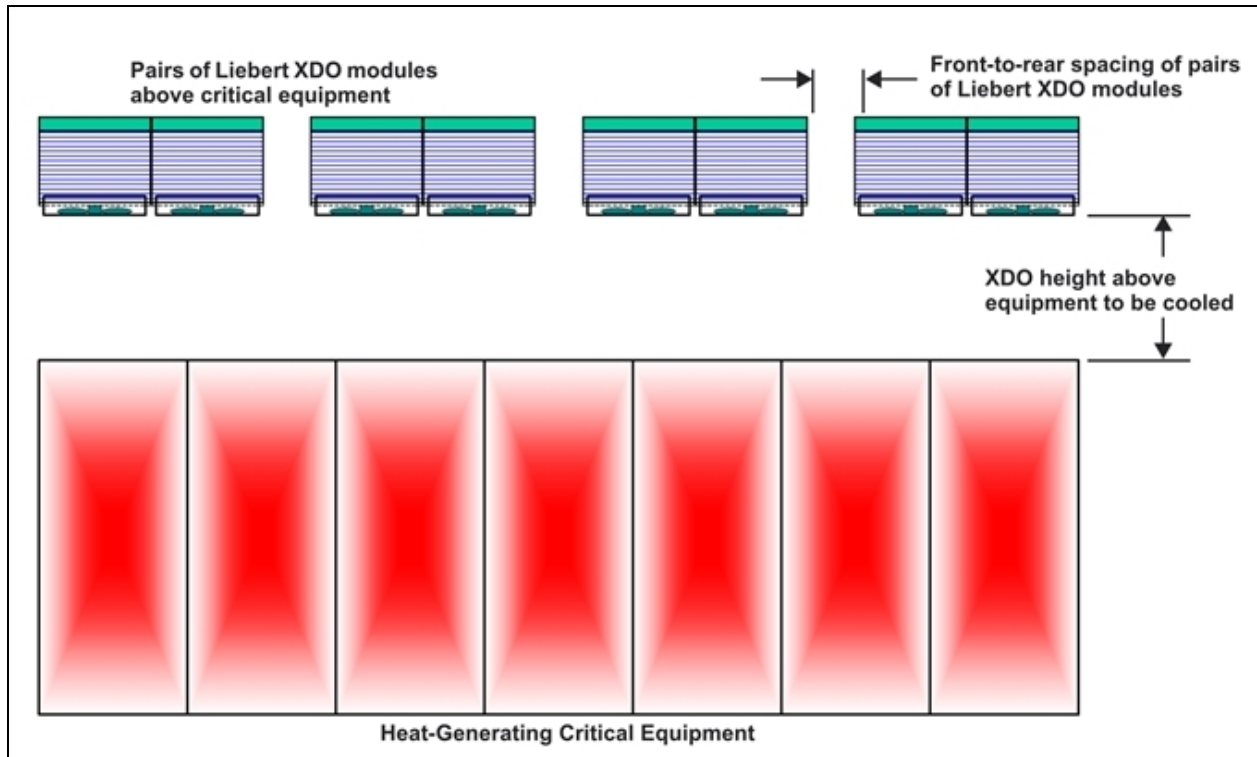

### 3.8.2 Determining Vertical Placement of Liebert XDOs Above the Cold Aisle

In the maximum density configuration, Vertiv recommends placing the Liebert XDOs between 18 and 24 inches (457-609mm) above the equipment cabinets. In some cases where the required density is less, the front-to-rear spacing of Liebert XDOs in a row will be increased. To ensure coverage of the wider spaces between the Liebert XDO modules, the vertical distance between the cabinets and the Liebert XDOs should be increased. However, the recommended maximum height of the Liebert XDO above the cabinets is 30 inches (762mm). See Figure 3.5 on the next page.

Figure 3.5 Liebert XDO placement over cold aisle

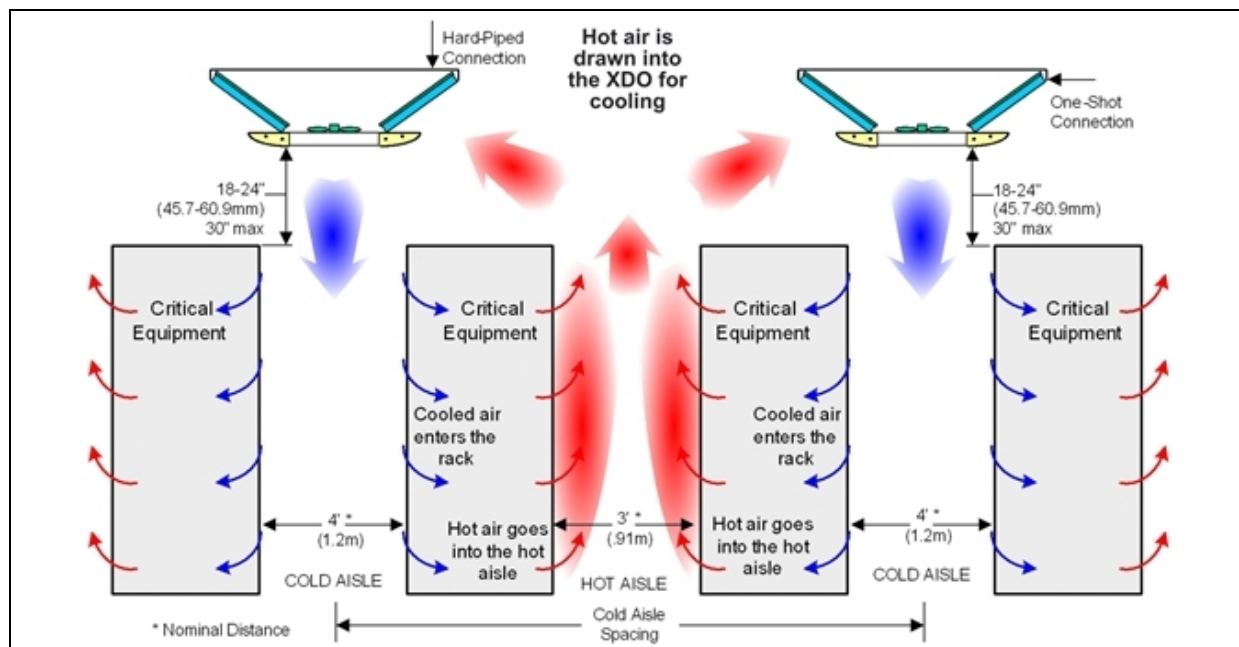

Table 3.4 below can be used to determine the correct number and spacing of Liebert XDOs.

Table 3.4 Calculating quantity and spacing of Liebert XDO modules (example below is Liebert XDO20)

Input Information	Step	Result
Total heat load in the room, kW	A	
Reserve capacity needed (10% to 25% of A is recommended)	B	
	C	Required cooling capacity, kW = A + B
Existing/planned Liebert Deluxe/Liebert DS unit sensible capacity, kW	D	
	E	Required Liebert XD system cooling capacity, kW = C - D
	F	Number of Liebert XDO20s required = $E \div 20$ , rounded up (60Hz) Number of Liebert XDO20s required = $E \div 16$ , rounded up (50Hz)
	G	Number of Liebert XDP/Liebert XDC units required = $F \div 8$ , rounded up (60Hz and 50Hz)
Room area, square feet	H	
	I	Area served by each Liebert XDO20 = $H \div F$
Spacing of cold aisles, center-to-center, typically 12-16 ft (3.7 to 4.9m)	J	
	K	Spacing between each Liebert XDO = $(I \div J) - 2$
	L	Required Liebert XD system cooling density = $E \times 1000 \div H$ OK if under 640; otherwise, additional cooling is required from Liebert Deluxe or Liebert DS units.

### 3.9 Liebert XDR Module Placement

The Liebert XDR does not require a hot aisle/cold aisle arrangement for effective and efficient operation. Refer to site-specific drawings for exact placement.

The Liebert XDR is engineered to fit the rear of computer enclosure cabinets. Ensure that there is 25.6" (649mm) clearance in the rear to allow the door to open fully.

### 3.9.1 Airflow

The server fans draw air into the equipment enclosure. After heated the air, the server fans force the air across the Liebert XDR's two coils. The Liebert XDR has a low air-side pressure drop (similar to a rack with perforated doors). The server fans within the rack create sufficient airflow to move the air.

**Figure 3.6 Generic airflow diagram**

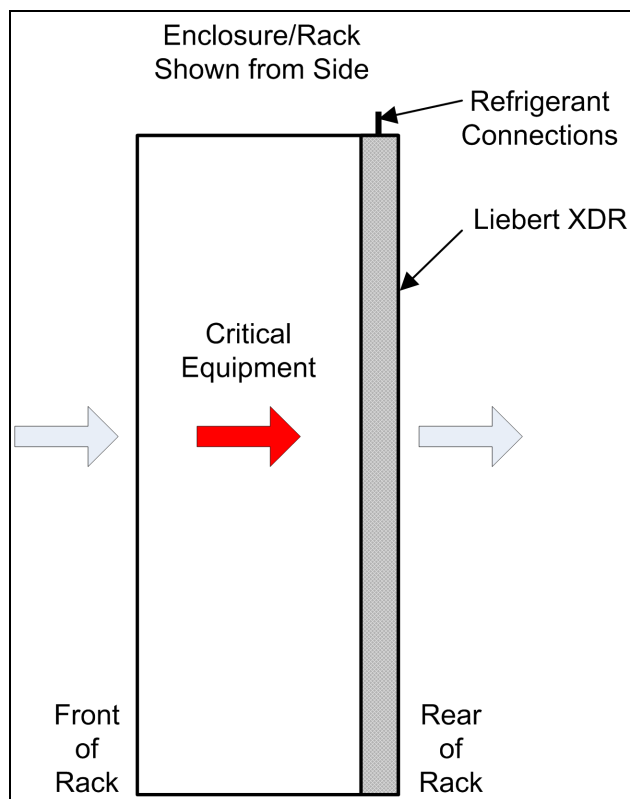

Efficient cooling of rack equipment depends on proper use of blanking plates in any voids in the rack and good cable management. Refer to the user manual supplied with the rack where the Liebert XDR is mounted. Keep the Liebert XDR's coils clear of any obstructions that might block the airflow.

Each of the Liebert XDR's coils removes approximately half the load. For even cooling in partially filled racks, servers should be evenly spaced and blanking plates should be installed on unused rack spaces to prevent recirculation of heated air. The top and bottom of the rack must be sealed with floor and ceiling panels. Not installing the panels will drastically reduce the Liebert XDR's performance.

**Table 3.5 Calculating quantity of Liebert XDR modules**

Input Information	Step	Result
Total heat load in the room, kW	A	
Reserve capacity needed (10% to 25% of A is recommended)	B	
	C	Required cooling capacity, kW = A + B
Existing/planned Liebert Deluxe/Liebert DS unit sensible capacity, kW	D	
	E	Required Liebert XD system cooling capacity, kW = C - D
	F	Number of Liebert XDR20s required = E ÷ 20, rounded up
	G	Number of Liebert XDP/Liebert XDC modules required = F ÷ 8, rounded up

### 3.10 Liebert XDV Module Placement

Liebert XDV modules should be placed on top of the cabinets that generate the greatest amount of heat. If heat loads are dispersed evenly throughout the room, the Liebert XDV modules may be spread out accordingly.

The Liebert XDV must be placed toward the front of the equipment cabinet, so that its front bottom edge is flush with the front top edge of the cabinet. Placing the module farther back on the top of the cabinet will restrict airflow into the cold aisle. Placing the module too far toward the front of the cabinet will decrease the amount of hot air drawn into the module.

**Figure 3.7 Positioning Liebert XDV on top of cabinet**

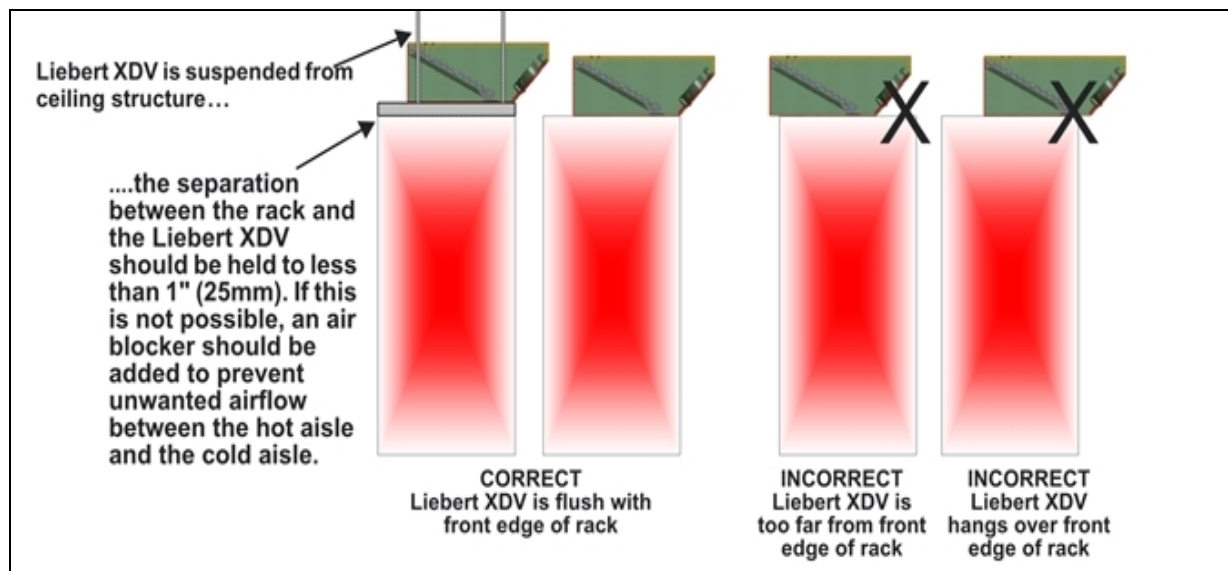

Both of the Liebert XDV’s power cords should be connected to power sources. If only one power source is available, then only the power cord labeled “SECONDARY” should be connected to the power source.

Piping for the Liebert XDV is routed upward to the main return and supply pipes to and from the Liebert XDP/Liebert XDC.

Table 3.6 on the facing page, below, may be used to determine the correct number of Liebert XDV modules.

**Table 3.6**

Determine required number of Liebert XDV modules (example below is Liebert XDV10)

Input Information	Step	Results
Total heat load in the room, kW	A	
Reserve capacity needed (10% - 25% of A is recommended)	B	
	C	Required cooling capacity, kW = A + B
Existing/planned Liebert Deluxe/DS sensible capacity, kW	D	
	E	Required Liebert XD system cooling capacity, kW = C - D
	F	Number of Liebert XDV10 modules required = $E \div 10$ , rounded up (60Hz) Number of Liebert XDV10 modules required = $E \div 8$ , rounded up (50Hz)
	G	Number of Liebert XDP/Liebert XDC units required = $F \div 16$ , rounded up (60Hz and 50Hz)
Room area, square feet	H	
	I	Area served by each Liebert XDV10 = $H \div F$
	L	Required Liebert XD system cooling density = $E \times 1000 \div H$ OK if under 580 for 12-foot cold aisle spacing OK if under 435 for 16-foot cold aisle spacing Otherwise, additional Liebert Deluxe or Liebert DS capacity is needed.

### 3.11 Liebert XDP/Liebert XDC Placement

The Liebert XDP/Liebert XDC may be placed in the critical space or in an adjacent equipment room. The allowable distance between the Liebert XDP/Liebert XDC and its connected cooling modules is determined by the piping design and by the amount of refrigerant required. Refer to [Liebert XD Refrigerant](#) on page 55 and [Liebert XD Piping System Design](#) on page 38.

The maximum height of any of the main or connecting piping should be no more than 20 feet (6m) above the top of the Liebert XDP/Liebert XDC unit. Liebert XDV/Liebert XDO modules should be placed as close to the same level as possible. The differences in elevation between the highest and lowest Liebert XDV or Liebert XDO module in a system should be no more than 6 feet (2m).

### 3.12 Examples of Expansion and Interlaced Connection of Liebert XD Cooling Modules

Figure 3.8 Liebert XDV modules mounted on racks emitting 3kW of heat, top view

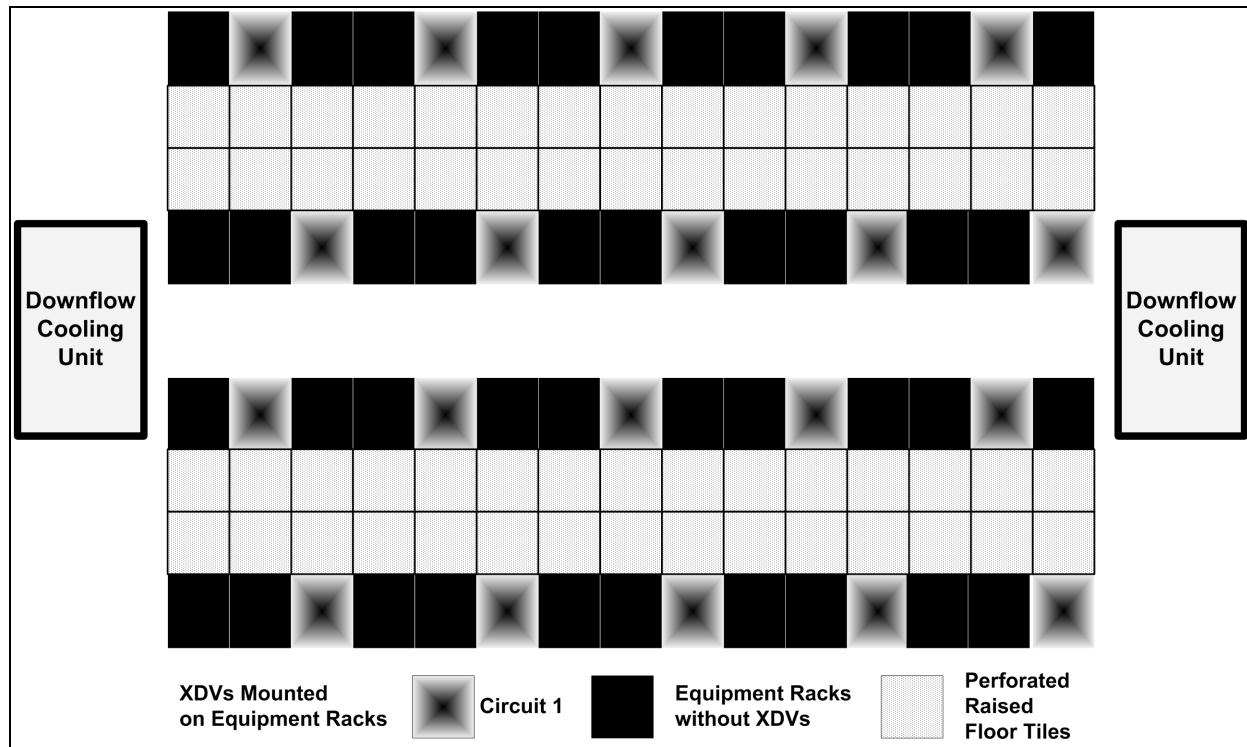



Figure 3.9 Liebert XDV modules mounted on racks emitting 5kW of heat, top view

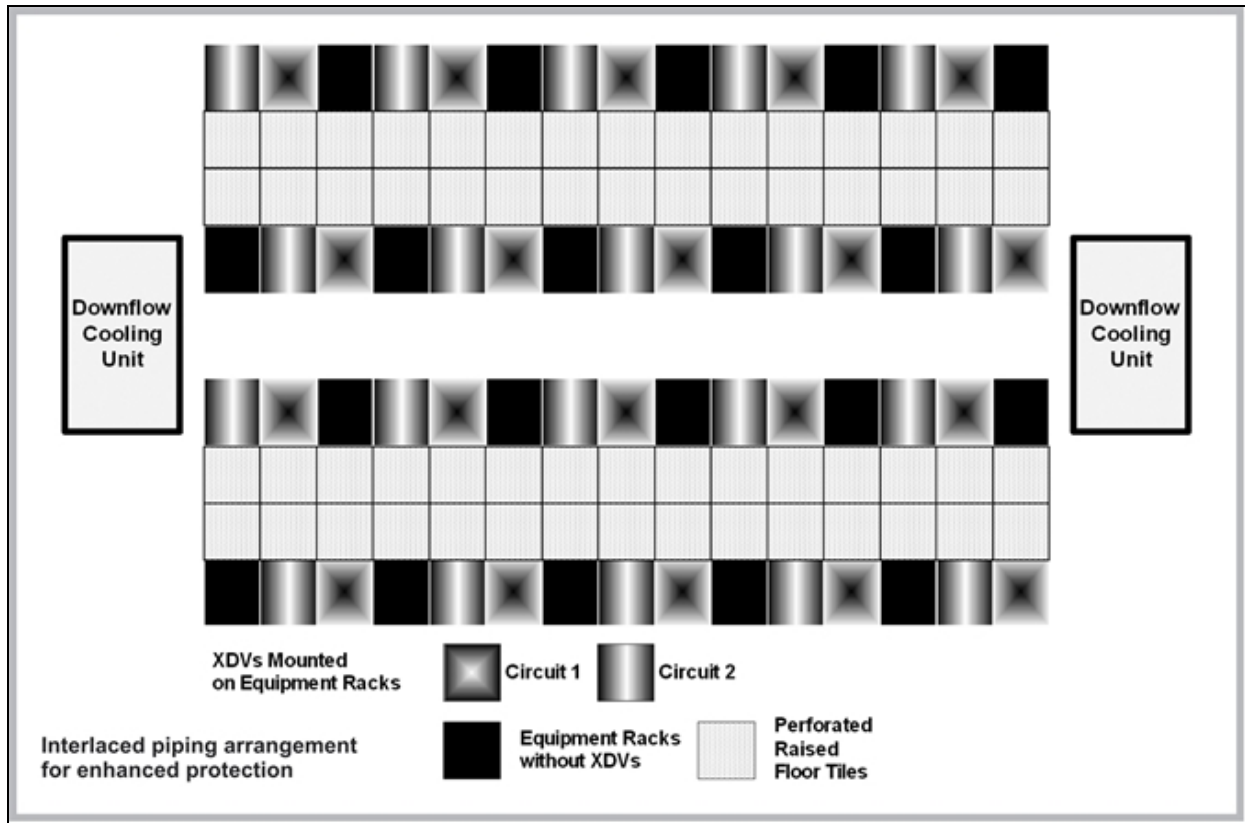

Figure 3.10 Liebert XDV modules mounted on racks emitting 8kW of heat top view

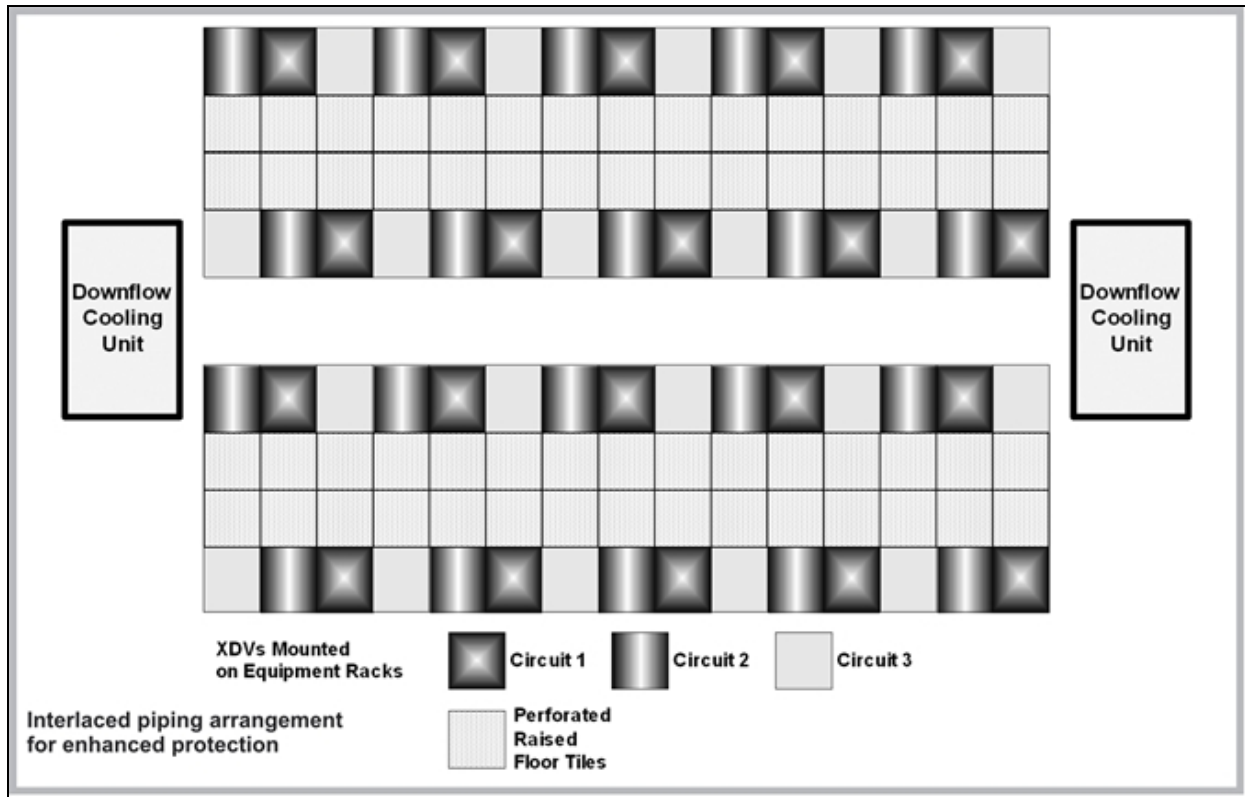

Figure 3.11 Liebert XDV modules mounted on racks emitting 16kW of heat top view

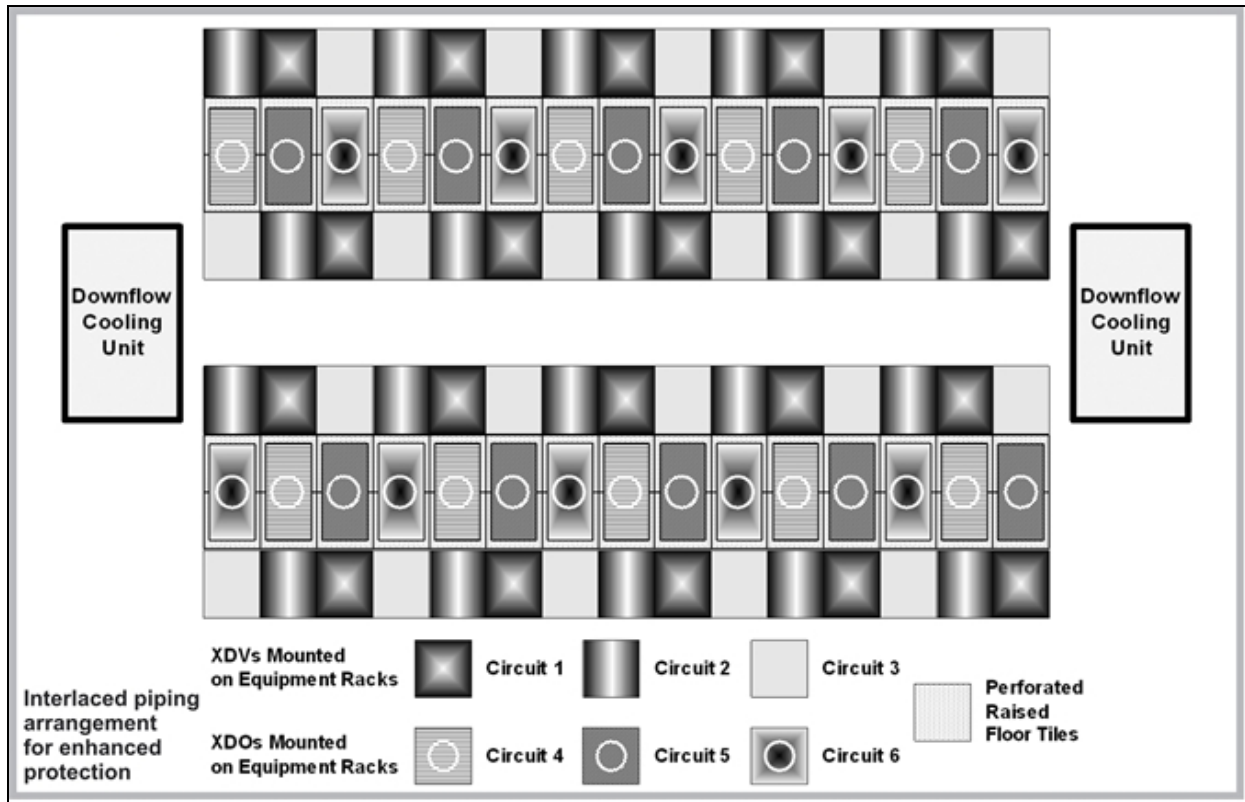
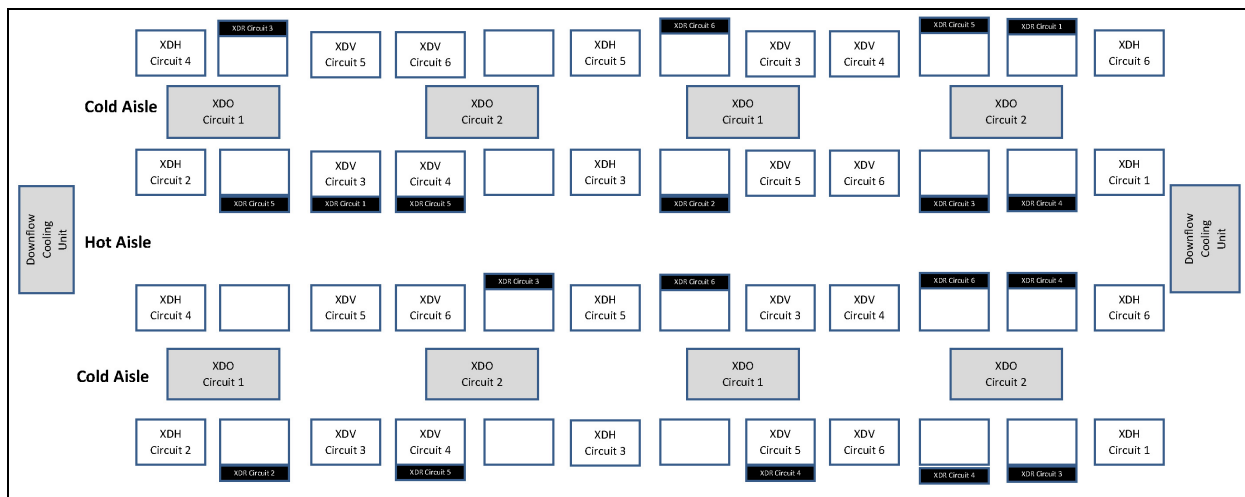
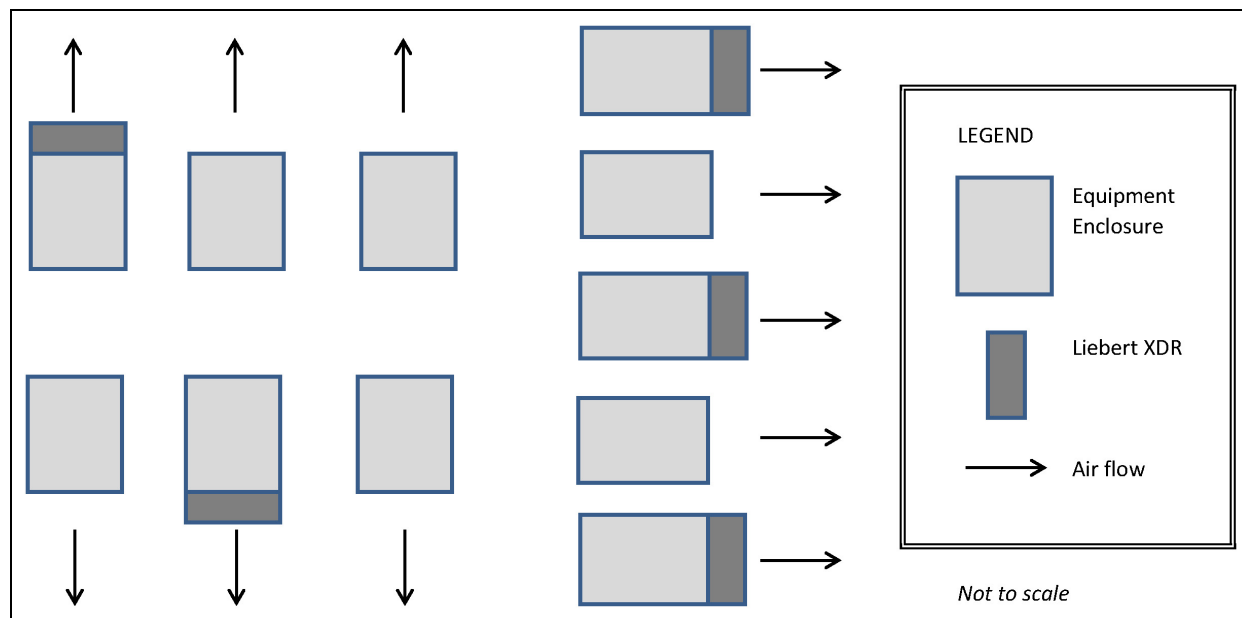

Figure 3.12 Multiple Liebert XD modules in an interlaced system



Installing the Liebert XDR in a hot aisle/cold aisle configuration provides benefits such as increased ride-through in the event of a failure. With the room-neutral cooling, the Liebert XDR can be used where hot aisle/cold aisle setup is not feasible to address hot spots (see Figure 3.13 on the next page).

Figure 3.13 Liebert XD modules not in hot aisle/cold aisle configuration



These methods can increase the redundancy of any Liebert XD system:

- Hot aisle/cold aisle design
- Interlacing the modules with different Liebert XDPs or Liebert XDCs
- Using multiple types of Liebert XD cooling modules
- Containment methods

### 3.13 Liebert XD Piping System Design

All piping must be ASTM (American Society for Testing and Materials) Type “ACR” copper pipe. The typical maximum operating pressure in the system is 90 psi (620kPa).

Piping for the Liebert XD system is arranged in a manner similar to piping for a chilled water system. Liebert XD cooling modules are connected in parallel between the main return and supply pipes going to and from the Liebert XDP/Liebert XDC. Figure 3.14 on the facing page represents a typical configuration. **The guidelines provided for pipe size must be strictly followed. Failure to size the main lines and connection lines adequately may result in reduced cooling capacity.** The critical aspects of pipe sizing are related to refrigerant volume and pressure drop. Each must be minimized.

Figure 3.14 Piping for Liebert XDP/Liebert XDC used with Liebert XD cooling modules

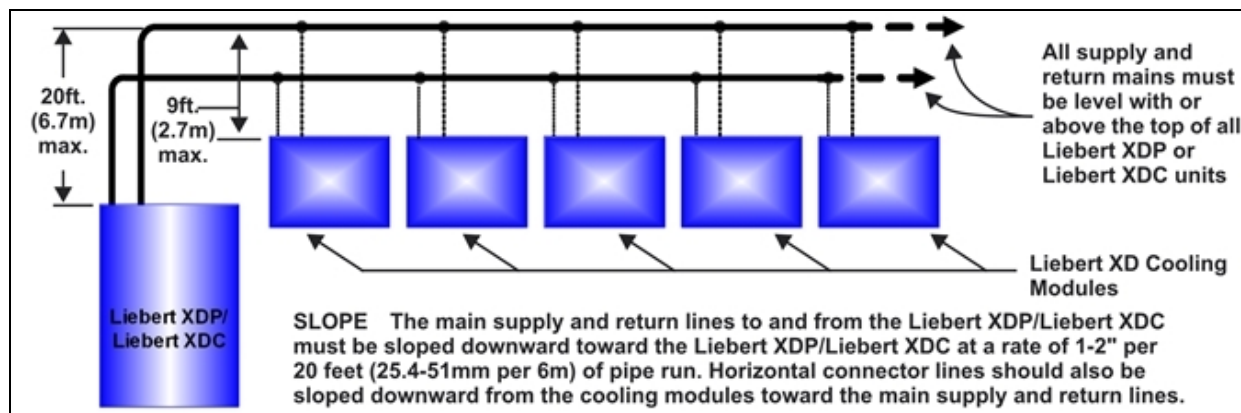

The assembly and connection means used for piping in the Liebert XD system are similar to that of conventional refrigeration systems. All piping should be installed with high temperature brazed joints. Soft solder is not recommended. The lines being brazed MUST be filled with flowing dry nitrogen during brazing to prevent excessive oxidation and scale formation inside the piping. Prevailing good refrigeration practices must be employed for piping supports, leak testing, dehydration and charging. Failure to use good system practices may result in damage to the system. Refer to the ASHRAE refrigeration handbook for general good-practice refrigeration piping.

Follow all guidelines in [Liebert XD Piping System Design](#) on the previous page and [Liebert XD Piping Slope](#) on the next page during installation.

Insulate all piping lines to prevent condensation in applications where the dew point approaches the R-134a refrigerant temperature. This might occur where Liebert XD module piping is above a dropped ceiling or in other areas not measured by sensors connected to the Liebert XDP or Liebert XDC.

See Table 3.7 below for recommended pipe sizes and Figure 3.15 on the next page for piping segment locations.

Table 3.7 Supply, return pipe sizes for refrigerant loop

Pipe Function	Key to Piping in Figure 3.15 on the next page	Size / Equivalent Pipe Length
Liebert XDP supply line, from Liebert XDP supply to farthest Liebert XD cooling module	A	1-1/8" OD for lengths up to 60 feet
		1-3/8" OD for lengths over 60 but less than 175 feet
Liebert XDP return line, from farthest Liebert XD cooling module to Liebert XDP return	B	2-1/8" OD for lengths up to 60 feet
		2-5/8" OD for lengths over 60 but less than 175 feet
From any model Liebert XDO/Liebert XDH/Liebert XDR supply to supply line of Liebert XDP	C	1/2" OD for lengths up to 10 feet
		7/8" OD for lengths over 10 but less than 25 feet
From any model Liebert XDO/Liebert XDH/Liebert XDR return to return line of Liebert XDP	D	7/8" OD for lengths up to 10 feet
		1-1/8" OD for lengths over 10 but less than 25 feet
From any model Liebert XDV/Liebert XDCF supply to supply line of Liebert XDP	C	1/2" OD for lengths up to 10 feet
		5/8" OD for lengths over 10 but less than 35 feet
From any model Liebert XDV/Liebert XDCF return to return line of Liebert XDP	D	5/8" OD for lengths up to 10 feet
		7/8" OD for lengths over 10 but less than 35 feet

For additional information about piping connections, see the unit's user manual: Liebert XDP, 16647; Liebert XDC, SL-16673; Liebert XDO, SL-16666; Liebert XDV, SL-16626; Liebert XDCF, SL-16678; Liebert XDR SL-16935; and Liebert XDH SL-17210.

**NOTE:** To minimize the amount of refrigerant required, do NOT oversize the piping.

Figure 3.15 Generic piping layout

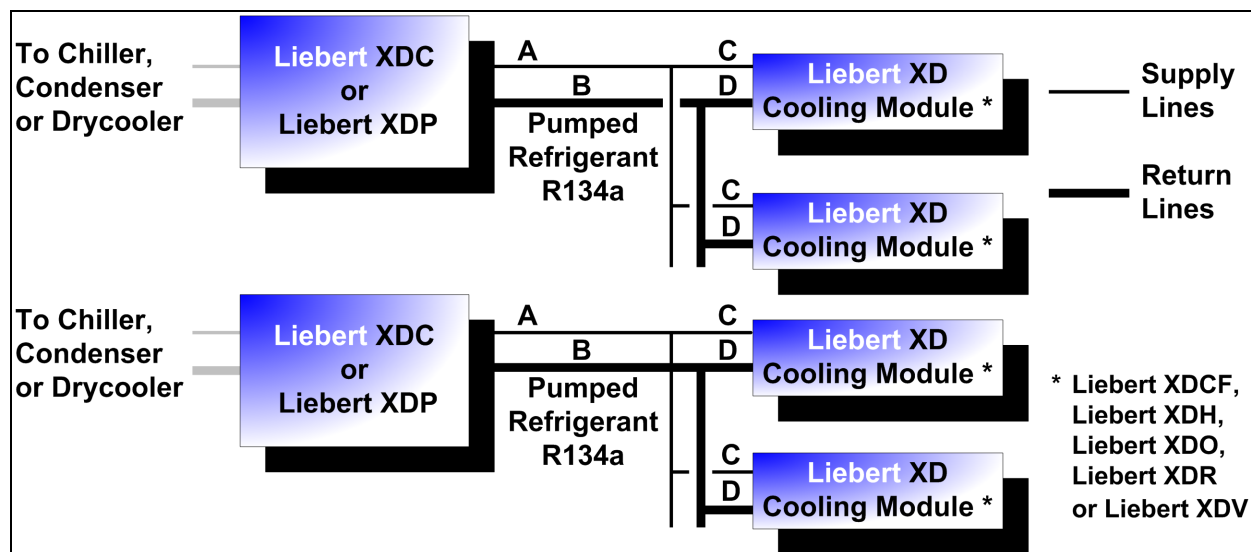

### 3.14 Liebert XD Piping Slope

The main supply and return lines to and from the XDP/XDC must be sloped downward toward the XDP/XDC at a rate of 1-2" per 20 feet (25-51mm per 6m) of pipe run. Horizontal connector lines should also be sloped downward from the cooling modules toward the main supply and return lines.

### 3.15 Bypass Flow Controllers

To ensure the Liebert XDP/XDC pumps operate within the optimum range, some installations require one or more bypass flow controller(s). These devices are added to the field piping, and simulate the flow of additional cooling modules.

Each bypass flow controller should be installed with one shutoff valve to allow the controller to be disabled when cooling modules are added to a Liebert XD system.

If bypass flow controllers are required, they should be connected between the main supply and the main return lines of the field piping. The connection points to the main supply and return lines should be in a convenient and accessible location between the Liebert XDP/Liebert XDC and the first Liebert XD module in the circuit. See Figure 3.17 on the facing page and Figure 3.16 on the facing page for piping details of the bypass flow controller.

Refer to Table 3.8 on the facing page to determine the number of bypass flow controllers needed, based on the total nominal cooling capacity of the cooling modules in each Liebert XD system.

**Table 3.8 Bypass flow controllers for Liebert XDC- or Liebert XDP-based systems**

Cooling Modules - Cumulative Model Size	Required Number of Bypass Flow Controllers	
	Liebert XDP	Liebert XDC
48 to 63	3	N/A
64 to 95	2	2
96 to 127	1	1
128 to 160	0	0

**Figure 3.16 Bypass flow controller details, dimensions**

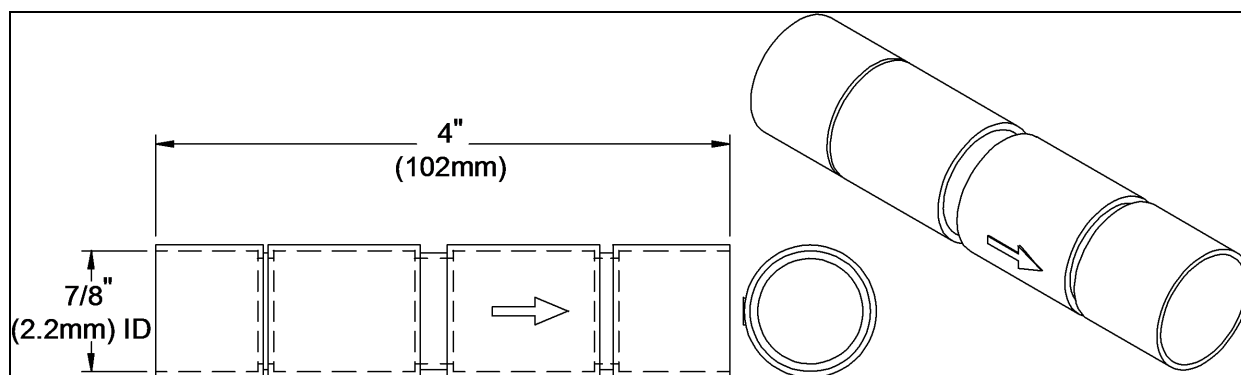

**Figure 3.17 Bypass flow controller arrangement**

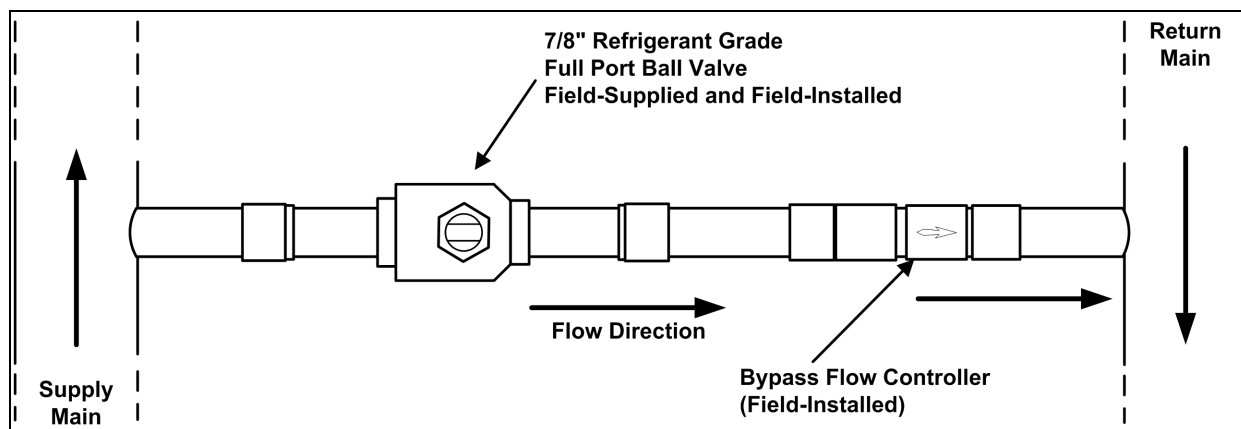
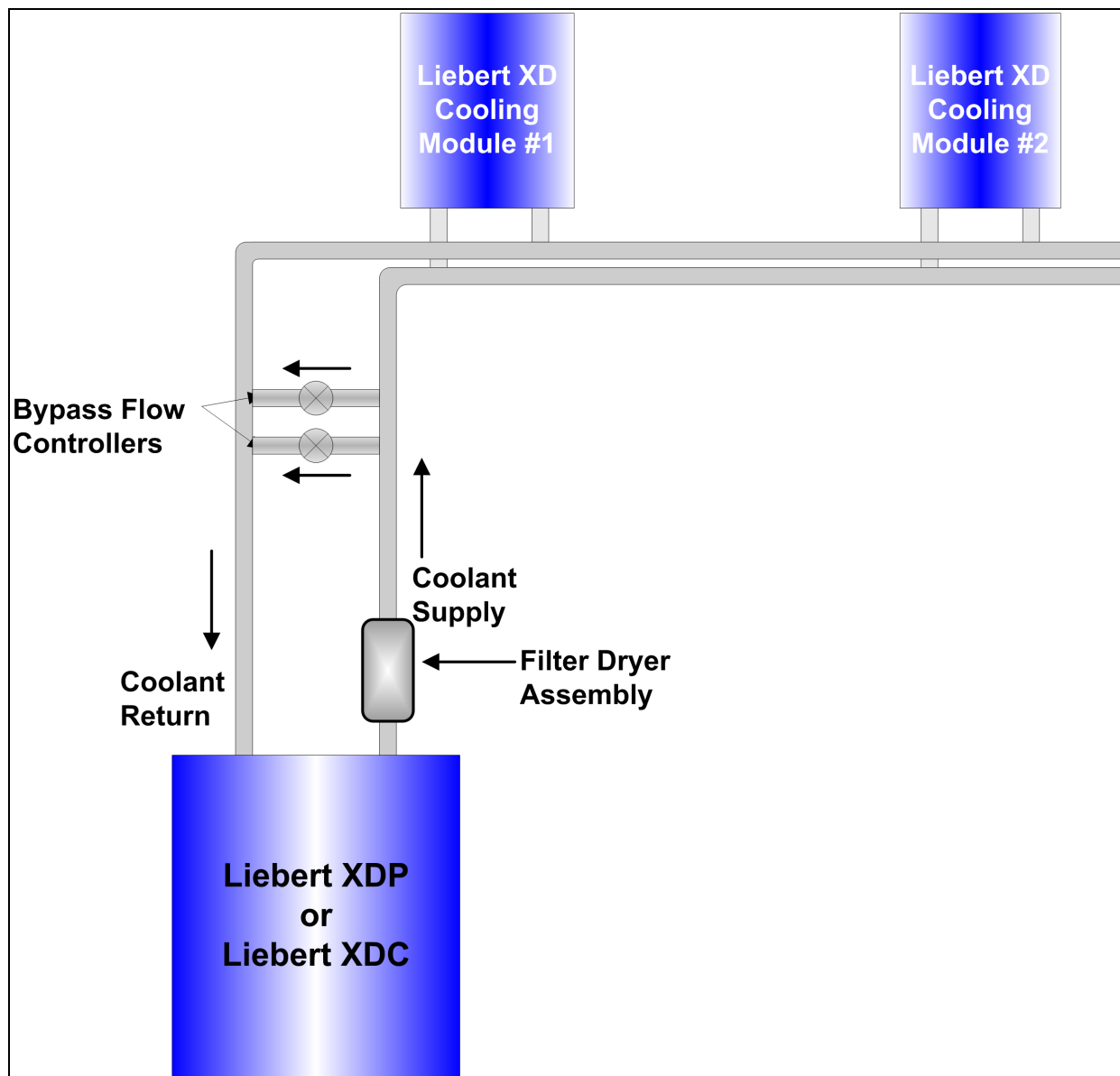

Figure 3.18 Bypass flow controller piping



### 3.16 Piping Details—Shutoff/Isolation Valves

Isolation valves must be installed on the Liebert XDC's refrigerant circuit to permit maintenance on the unit (see Figure 3.19 on the facing page).



Figure 3.19 General piping details

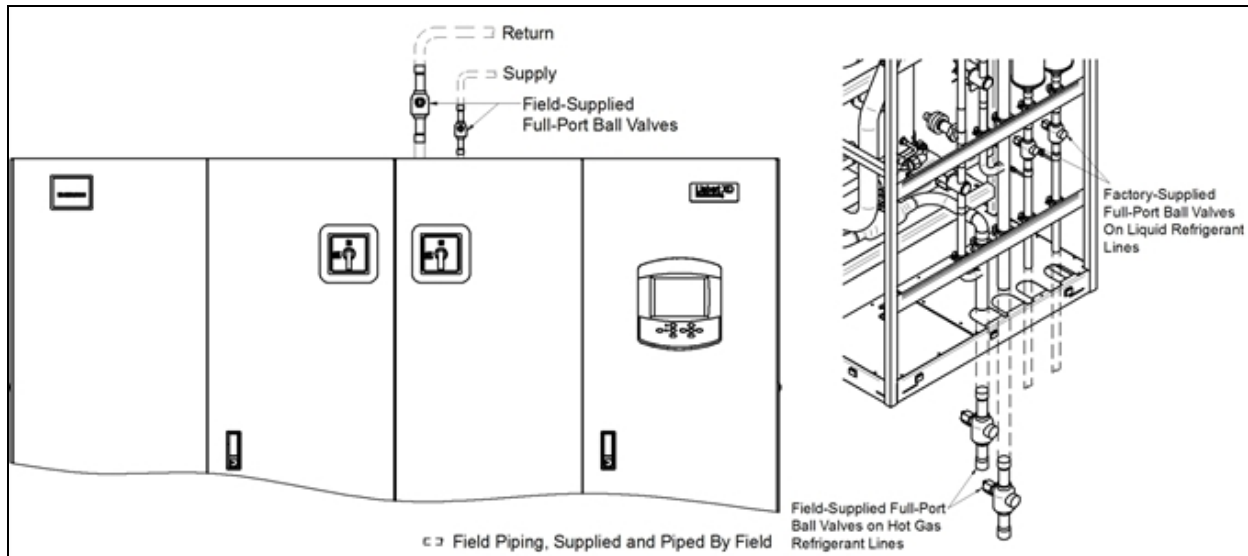

### 3.17 Piping Details—Shutoff/Isolation Valves

Isolation valves must be installed on the Liebert XDP's refrigerant circuit to permit maintenance on the unit (see Figure 3.20 below).

Figure 3.20 General piping details

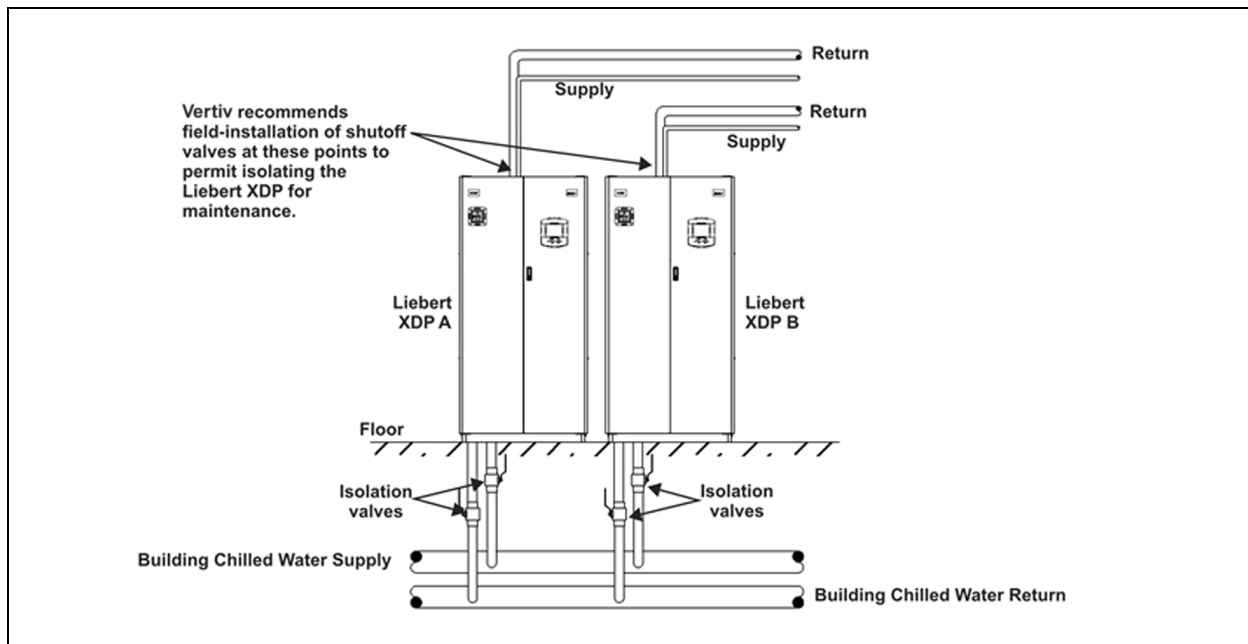
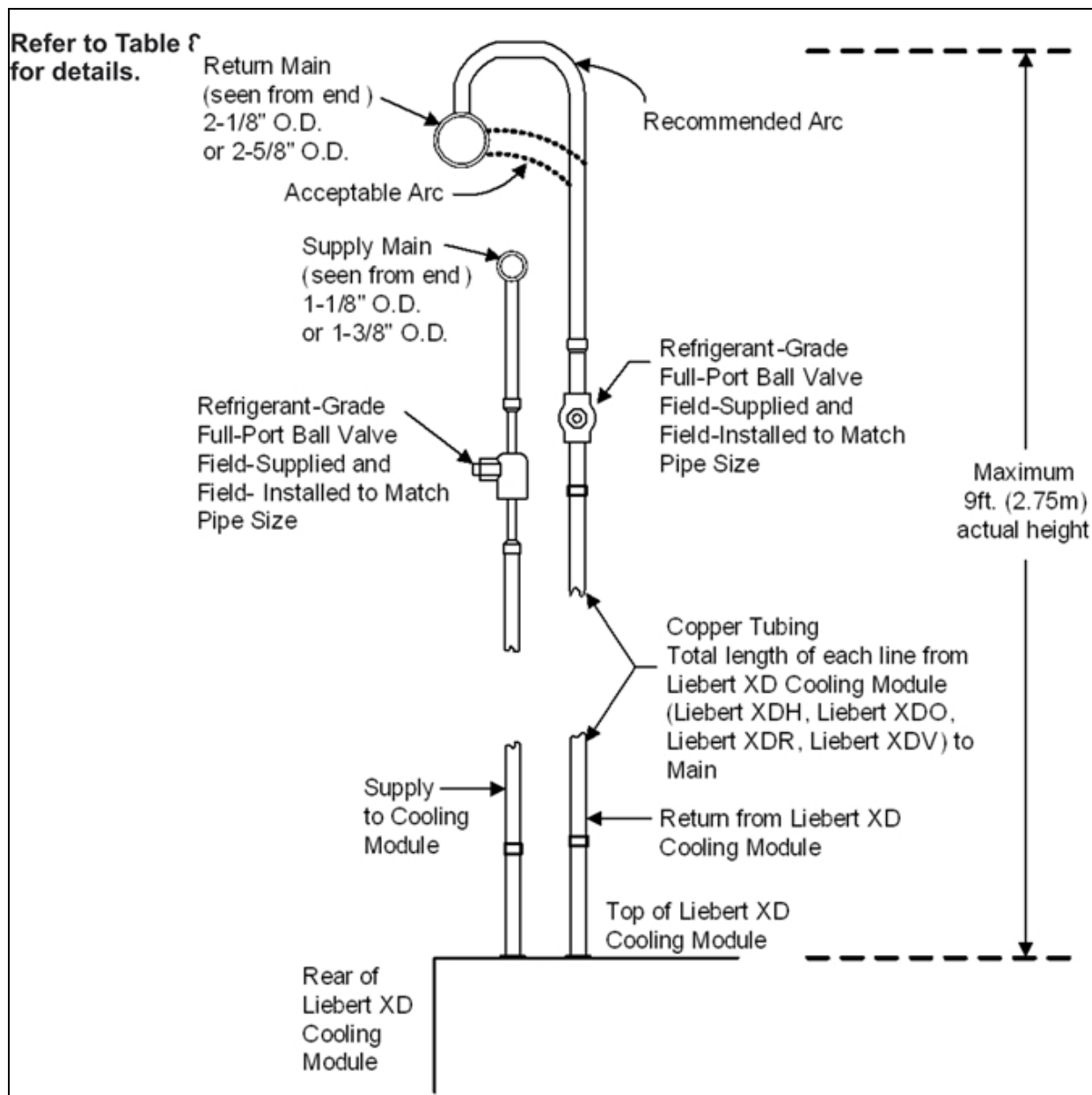

Figure 3.21 Hard-pipe connection diagram for Liebert cooling modules



### 3.18 Piping Details—Return Header Port Orientation

The return header port from a Liebert XD cooling module is a gravity return and must be properly oriented to the refrigerant return header for proper flow. The return header contains R134a refrigerant in gas and liquid form. Improperly connecting a cooling module’s return header port to the return header could permit liquid refrigerant to back up into the cooling module. See Figure 3.22 on the facing page for proper orientation.

Supply header ports can be oriented at any angle to the header because supply headers carry only liquid R134a refrigerant and are not gravity operated.

Figure 3.22 Liebert XD return header orientation

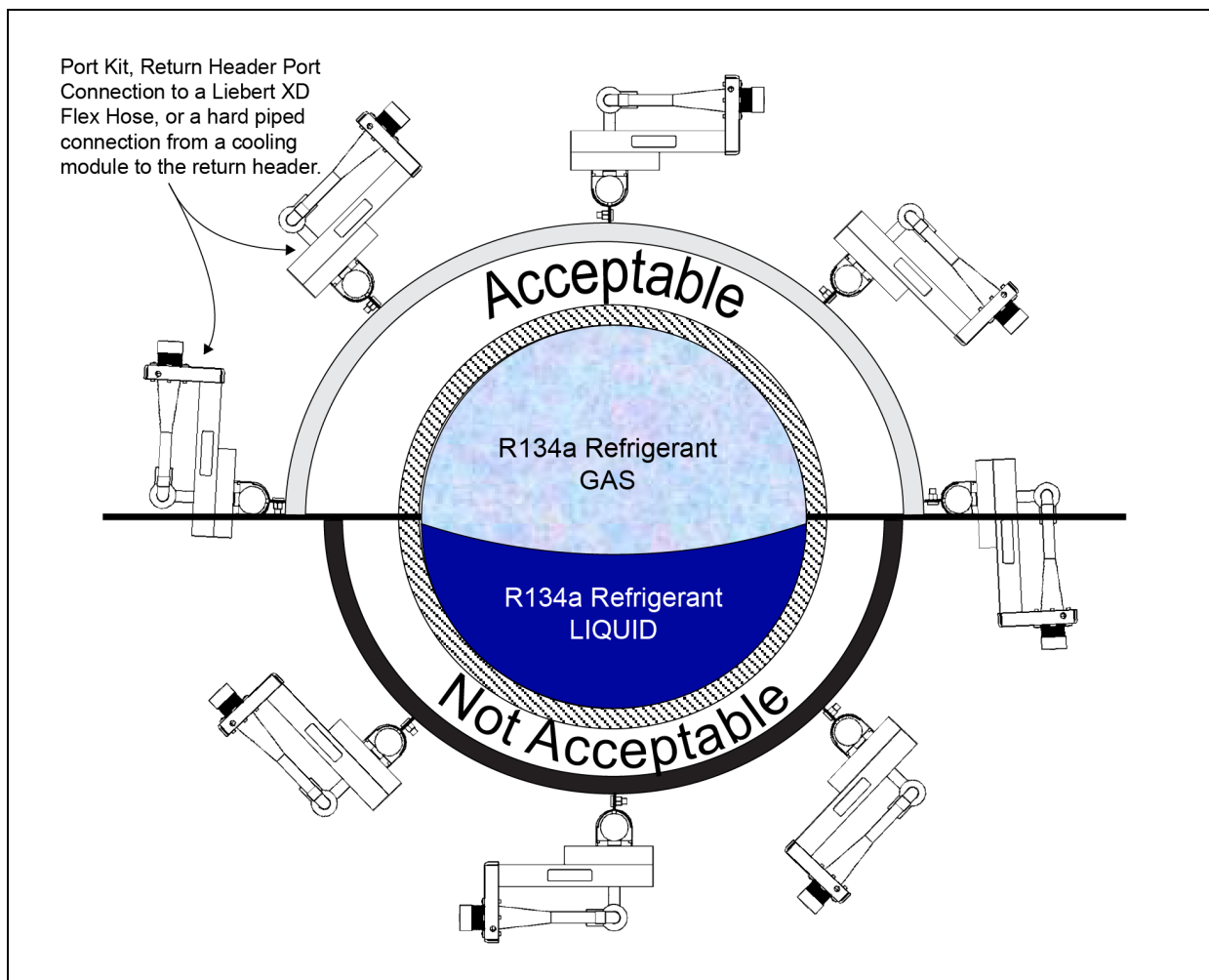
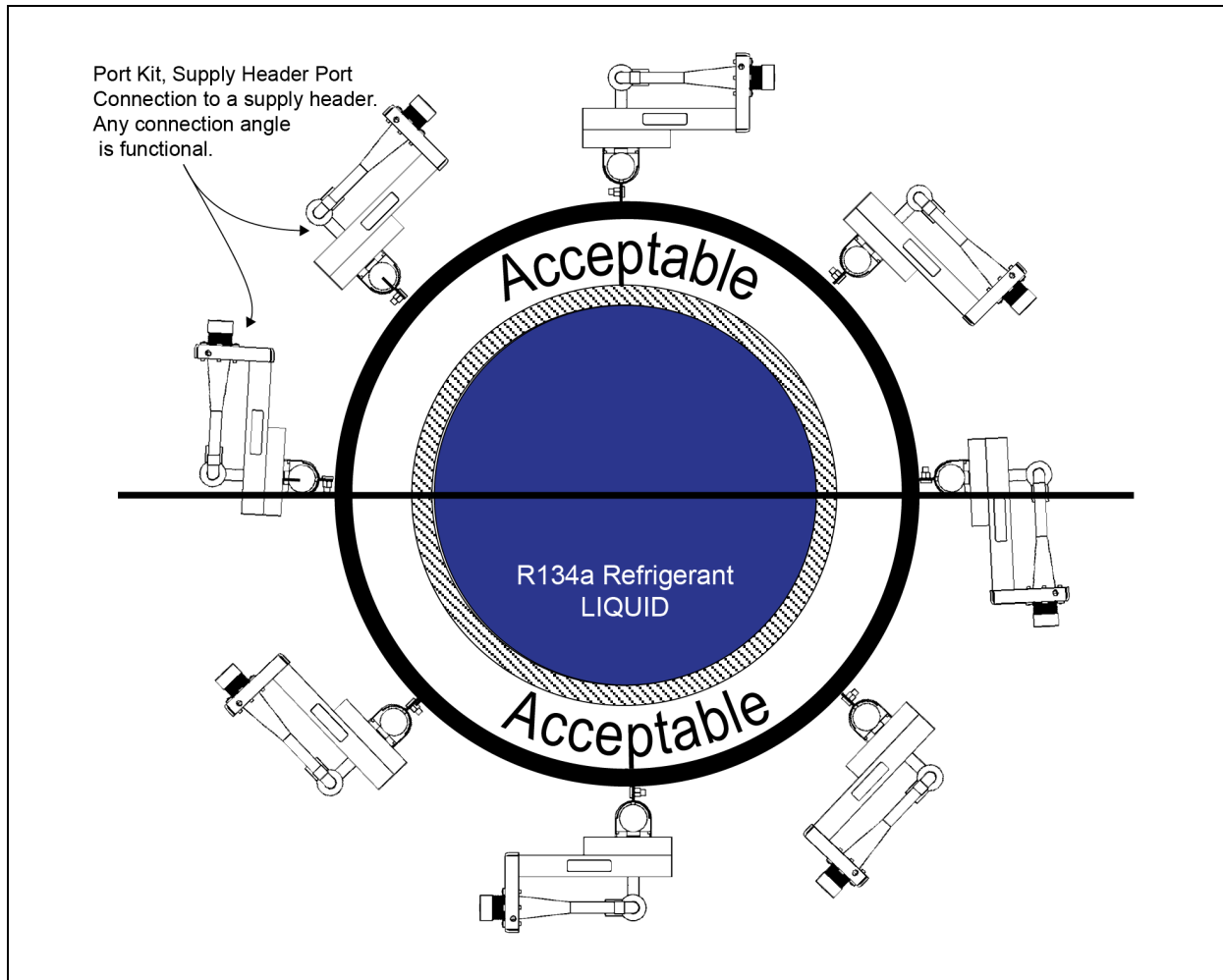

Figure 3.23 Liebert XD supply header orientation



### 3.19 Piping Details—Bull Heading Layout

Good piping layout employs offsetting connections to promote easier refrigerant flow, as shown in Figure 3.24 on the facing page. “Bull head T” connections should be avoided.

Figure 3.24 Efficient piping layout—avoid “bull head T” connections

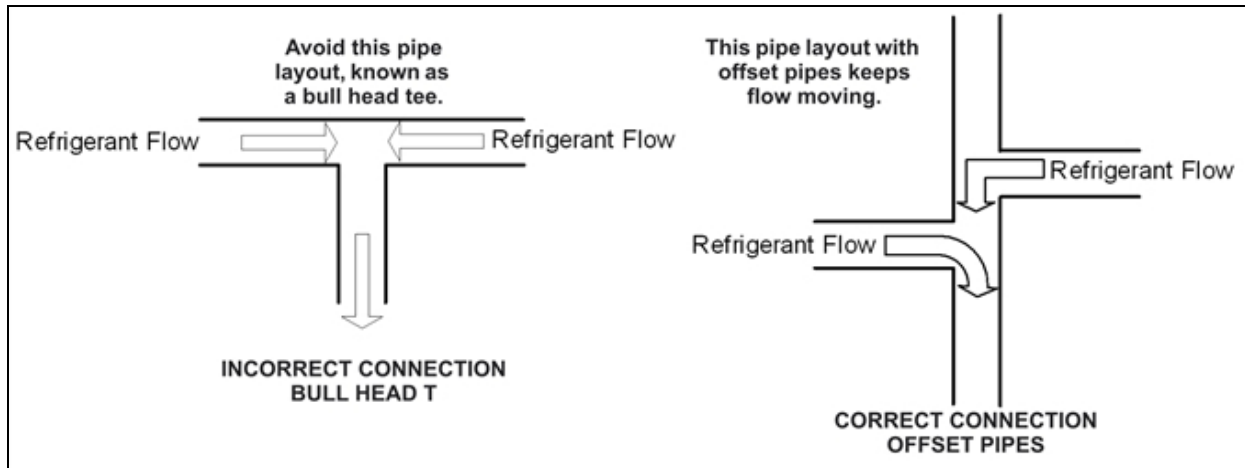

### 3.20 Piping Installation Method Prefabricated Headers

The assembly and connection means used for piping in the Liebert XD system are similar to those used for conventional refrigeration systems. All piping should be installed with high-temperature brazed joints. Soft solder is not recommended. During brazing, the lines must be filled with flowing dry nitrogen to prevent excessive oxidation and scale formation inside the piping. Prevailing good refrigeration practices must be employed for piping supports, leak testing, dehydration and charging. Failure to use good system practices may result in damage to the system. Refer to the ASHRAE refrigeration handbook for general good-practice refrigeration piping.

Follow all guidelines in [Liebert XD Piping System Design](#) on page 38 and [Liebert XD Piping Slope](#) on page 40 during installation.

Figure 3.25 Two-port prefabricated piping for Liebert XD cooling modules

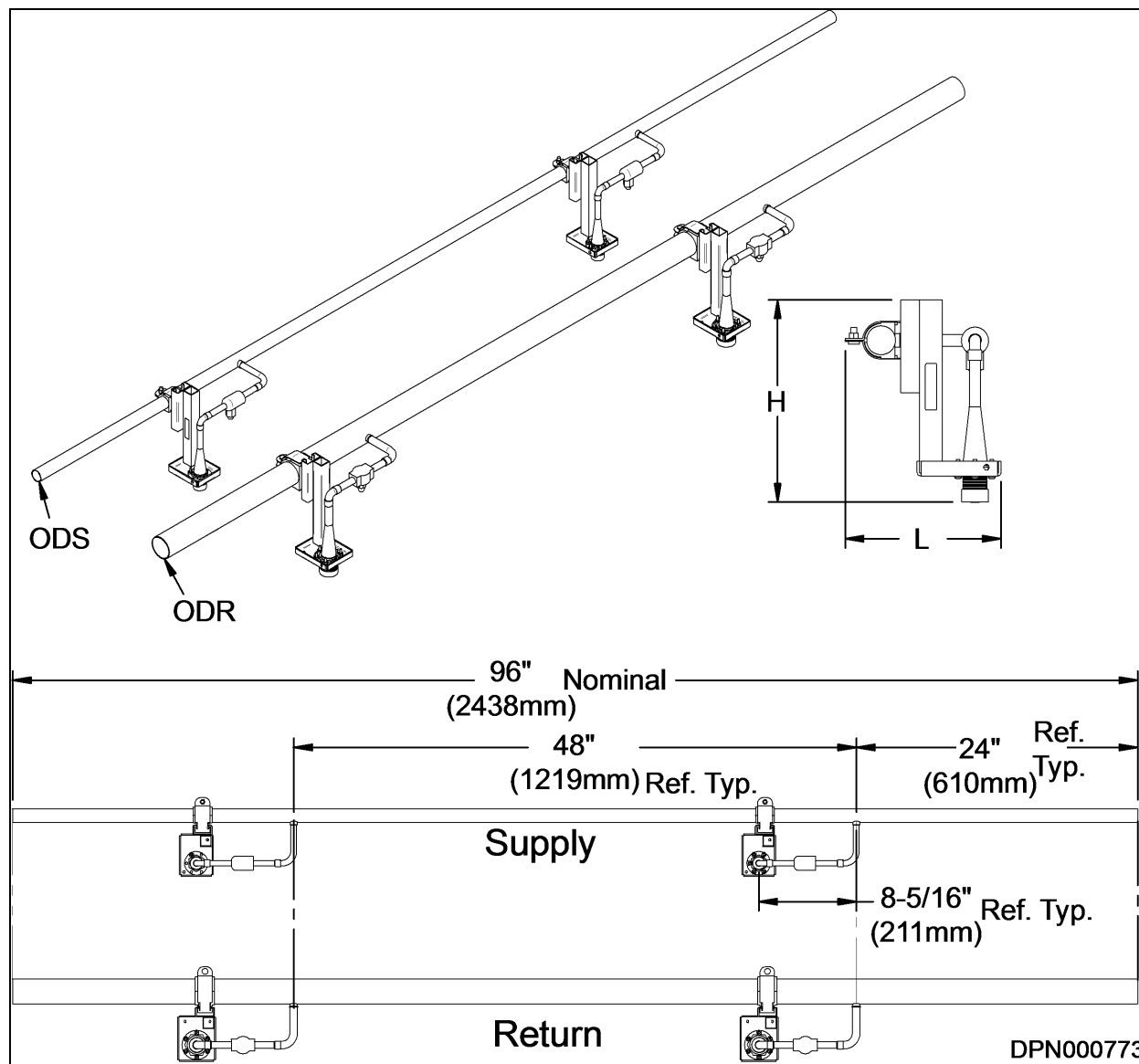

**Table 3.9 Two-port prefabricated piping legend**

Branch Piping		Standard Run	Long Run *
Two Port		185797G21	185800G21
Supply inch (mm)	Outside Diameter (ODS)	1-1/8	1-3/8
	Height (H)	8-3/4 (222)	8-3/4 (222)
	Length (L)	6-3/4 (171)	
Return inch (mm)	Outside Diameter (ODR)	2-1/8	2-5/8
	Height (H)	10-1/2 (267)	10-1/2 (267)
	Length (L)		9-1/8 (232)
* Pipe runs greater than 60 equivalent feet			

Figure 3.26 Four-port prefabricated piping for Liebert XD cooling modules

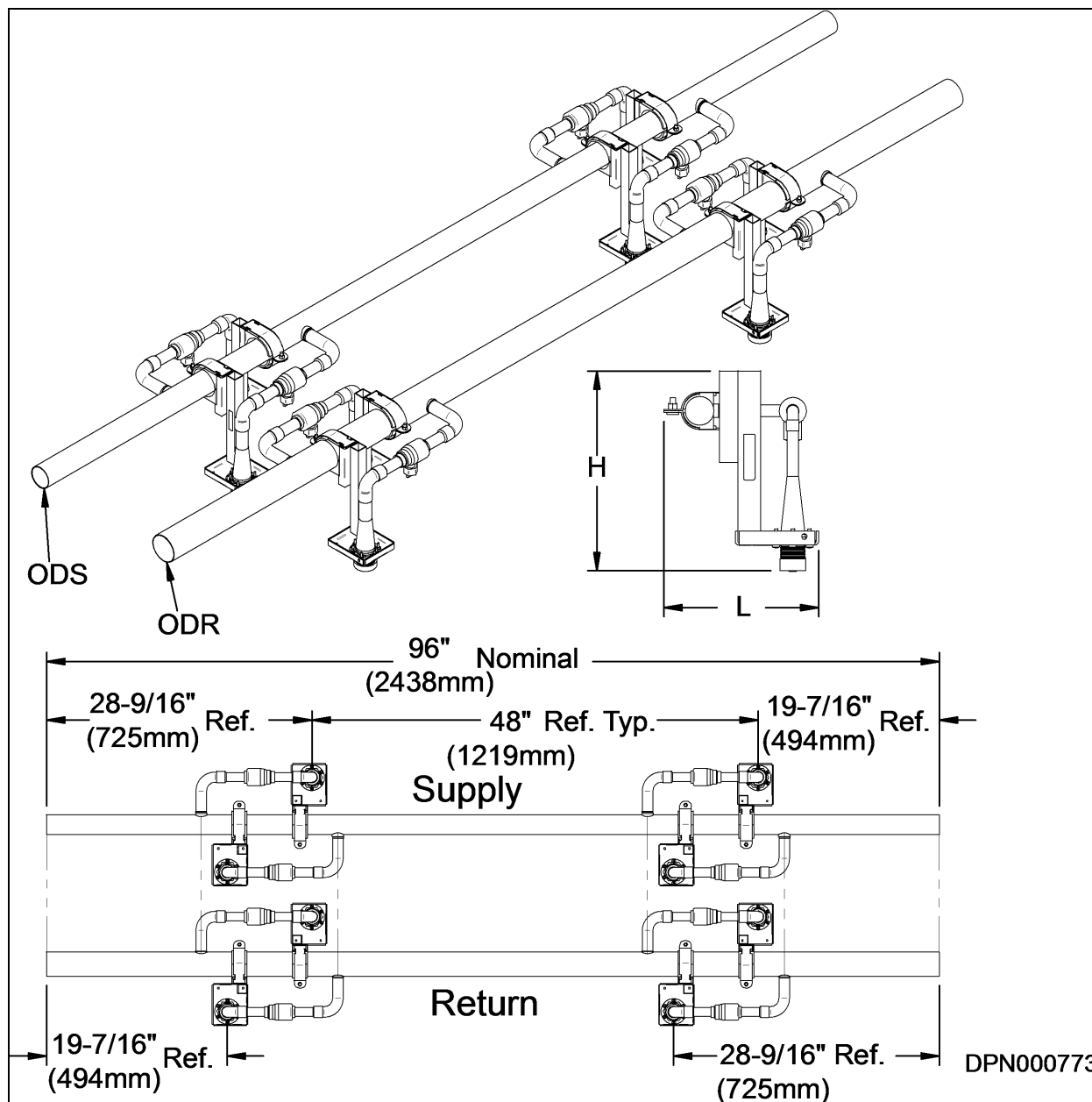

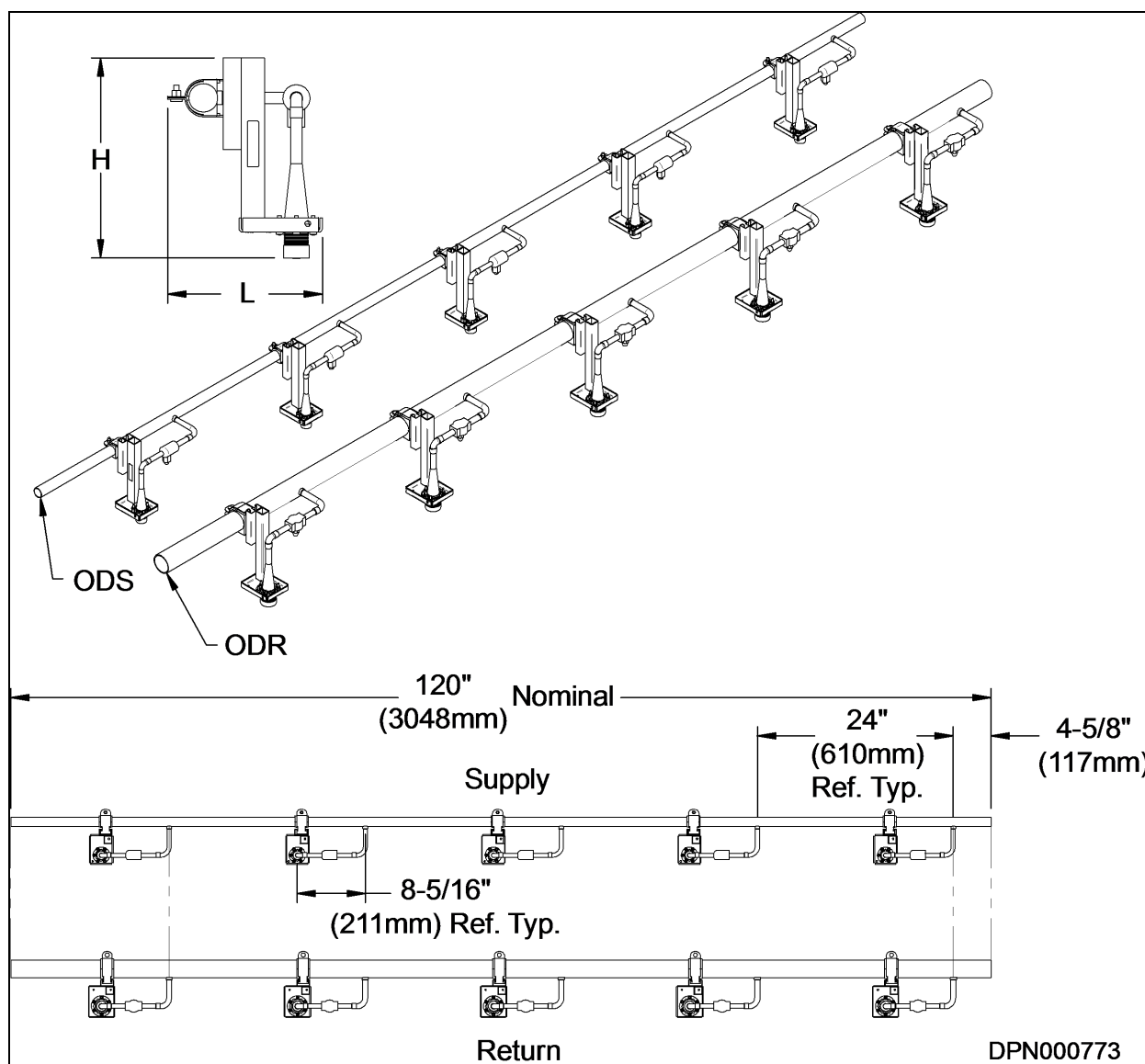

**Table 3.10 Four-port prefabricated piping legend**

Branch Piping		Standard Run	Long Run *
Four Port		186551G21	186552G21
Supply inch (mm)	Outside Diameter (ODS)	1-1/8	1-3/8
	Height (H)	8-3/4 (222)	8-3/4 (222)
	Length (L)	6-3/4 (171)	
Return inch (mm)	Outside Diameter (ODR)	2-1/8	2-5/8
	Height (H)	10-1/2 (267)	10-1/2 (267)
	Length (L)		9-1/8 (232)

\* Pipe runs greater than 60 equivalent feet

**Figure 3.27 Five-port prefabricated piping for Liebert XD cooling modules**



**Table 3.11 Five-port prefabricated piping legend**

Branch Piping		Standard Run	Long Run *
Five Port		185797G51	185800G51
Supply inch (mm)	Outside Diameter (ODS)	1-1/8	1-3/8
	Height (H)	8-3/4 (222)	8-1/2 (216)
	Length (L)	6-3/4 (171)	
Return inch (mm)	Outside Diameter (ODR)	2-1/8	2-5/8
	Height (H)	10-1/2 (267)	10-1/2 (267)
	Length (L)		9-1/8 (232)
* Pipe runs greater than 60 equivalent feet			

Figure 3.28 Ten-port prefabricated piping for Liebert XD cooling modules

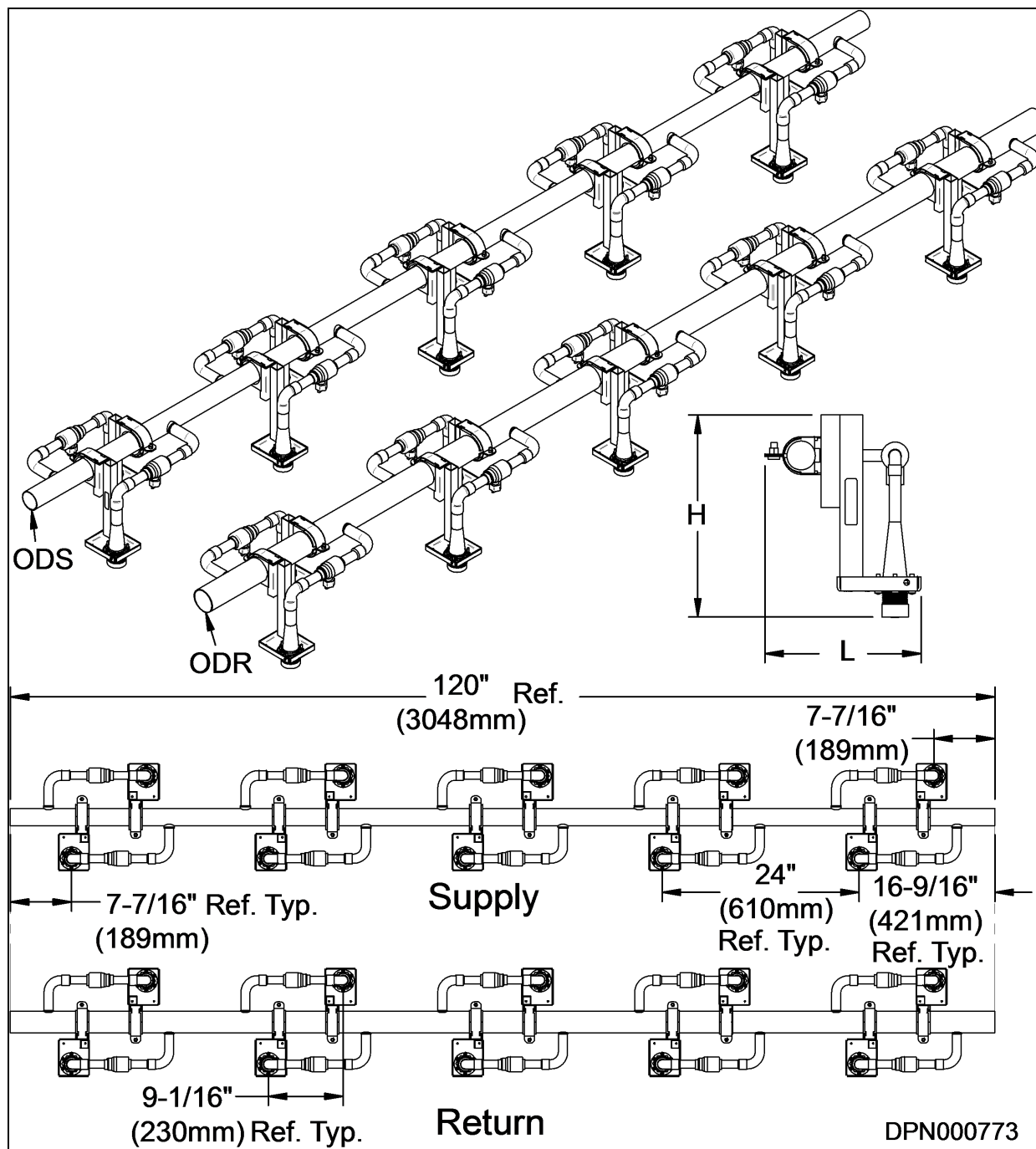

**Table 3.12 Ten-port prefabricated piping legend**

Branch Piping		Standard Run	Long Run *
Ten Port		186650G51	186553G51
Supply inch (mm)	Outside Diameter (ODS)	1-1/8	1-3/8
	Height (H)	8-3/4 (222)	8-3/4 (222)
	Length (L)	6-3/4 (171)	6-7/8 (175)
Return inch (mm)	Outside Diameter (ODR)	2-1/8	2-5/8
	Height (H)	10-1/2 (267)	10-1/2 (267)
	Length (L)		9-1/8 (232)

\* Pipe runs greater than 60 equivalent feet

### 3.21 Liebert XD Flex Pipe Kit

Liebert XD Flex Pipe kits are available in lengths of 4, 6, 8 and 10 feet (1.2, 1.8, 2.4 and 3 meters). Connection style to the module end may be straight or 90 degrees with one-shot or removable connections. Connection to the prefabricated piping assembly is a threaded coupler. For data on acquiring the correct kit for your installation, see Table 3.13 below.

**Table 3.13 Liebert XD Flex Pipe assemblies, supply and return**

Description	Liebert XDV		Liebert XDCF	Liebert XDO	Liebert XDH		Liebert XDR	
	One-Shot Couplings	Removable Couplings	One-Shot Coupling	One-Shot Coupling	One-Shot Coupling	Removable Couplings	One-Shot Coupling	Removable Couplings
4ft long (1.2m), 0°	186568G4	187867G4	186568G4 <sup>2</sup>	186566G4	2 x 186566G4	2 x 187865G4	186566G4	187865G4
4ft long (1.2m), 90°	186567G4	187866G4	—	186565G4	2 x 186565G4	2 x 187864G4	186565G4	187864G4
6ft long (1.8m), 0°	186568G1	187867G1	186568G1 <sup>2</sup>	186566G1	2 x 186566G1	2 x 187865G1	186566G1	187865G1
6ft long (1.8m), 90°	186567G1	187866G1	—	186565G1	2 x 186565G1	2 x 187864G1	186565G1	187864G1
8ft long (2.5m), 0°	186568G3	187867G3	186568G3 <sup>3</sup> . on the facing page	186566G3	2 x 186566G3	2 x 187865G3	186566G3	187865G3
8ft long (2.5m), 90°	186567G3	187866G3	—	186565G3	2 x 186565G3	2 x 187864G3	186565G3	187864G3

**Table 3.13 Liebert XD Flex Pipe assemblies, supply and return (continued)**

Description	Liebert XDV		Liebert XDCF	Liebert XDO	Liebert XDH		Liebert XDR	
	One-Shot Couplings	Removable Couplings	One-Shot Coupling	One-Shot Coupling	One-Shot Coupling	Removable Couplings	One-Shot Coupling	Removable Couplings
10ft long (10m), 0°	186568G2	187867G2	186568G2 <sup>3</sup>	186566G2	2 x 186566G2	2 x 187865G2	186566G2	187865G2
10ft long (10m), 90°	186567G2	187866G2	—	186565G2	2 x 186565G2	2 x 187864G2	186565G2	187864G2
Min Bend Radius, Supply <sup>1</sup>	7" (178mm)	7" (178mm)	7" (178mm)	7" (178mm)	7" (178mm)	7" (178mm)	7" (178mm)	7" (178mm)
Min Bend Radius, Return <sup>1</sup>	8" (203mm)			9" (229mm)				
<ol style="list-style-type: none"> <li>1. The minimum bend radius is for the flexible portion of the Liebert XD Flex Pipe. Because a section of hard pipe is at each end of the Liebert XD Flex Pipe, the minimum bend radius can be larger.</li> <li>2. Top Module</li> <li>3. Bottom Module</li> </ol>								

### 3.22 Liebert XD Refrigerant

The refrigerant used in the Liebert XD system is HFC-134a (1,1,1,2-tetrafluoroethane), made by a number of manufacturers. The amount of refrigerant used by the Liebert XD system may be significantly higher than in typical DX cooling systems.

#### NOTICE

Risk of improper oil use. Can cause equipment damage.

The Liebert XD pumped R-134a refrigerant circuits do not use refrigerant oil. Do NOT put oil in the R-134a system.

All the major components of a Liebert XD system must be installed in a space with a volume of at least 1,000 ft<sup>3</sup> (28.3m<sup>3</sup>) for each 13 pounds of refrigerant in that system from ANSI/ASHRAE Standard 34-2007, *Designation and Safety Classification of Refrigerant*. If the Liebert XDP/Liebert XDC is placed in a separate area, such as a machine room, then this area must also meet the volume requirement. Inside the critical space, this includes the space under the raised floor, and the space between the top of the raised floor and the bottom of a suspended ceiling. If the suspended ceiling is all open grates, then this additional space, up to the overhead deck, would also be included.

#### Example

A space is 5,000 square feet, with an 18" raised floor and an 8' 6" suspended ceiling. Liebert XDOs and a Liebert XDP are to be placed in this raised-floor area.

The volume of the space is (1.5 + 8.5) x 5,000 or 50,000 cubic feet.

The maximum amount of R-134a refrigerant that can be used in a single Liebert XDP/Liebert XDC/Liebert XD module system within this space is  $13 * (50000/1000) = 13 * 50 = 650$  lb.

Multiple Liebert XD systems can be installed in this space, as long as the amount of R-134a refrigerant in any one system does not exceed 650lb. (294.8kg).The maximum amount of refrigerant is 650lb (294.8kg) per Liebert XD loop.

**NOTE: Local codes might permit exceeding the maximum refrigerant limit above if a refrigerant detector and an exhaust system are installed. Installing oxygen sensors may meet some local codes.**

### 3.23 Determining Refrigerant Volume

After the preliminary system design is completed, Table 3.14 below through Table 3.19 on page 58 may be used to determine the amount of refrigerant required. Perform the calculation below for each Liebert XD system being configured.

**NOTE: All lengths in Table 3.14 below, Table 3.15 below, Table 3.16 on the facing page and Table 3.17 on the facing page, are actual pipe lengths, not equivalent pipe lengths.**

#### 3.23.1 Liebert XDP/Liebert XDC Pumped R-134a Circuit Volume

This is the refrigerant circuit from the Liebert XDP/Liebert to the Liebert XD cooling module.

**NOTE: System refrigerant volume calculations in Table 3.14 below, Table 3.15 below, Table 3.16 on the facing page and Table 3.17 on the facing page, are based on a fully loaded system. Additional charge may be required for lightly loaded systems.**

**Table 3.14 System R-134a charge for a Liebert XDP/Liebert XDC with any model Liebert XDH/Liebert XDO/Liebert XDV/Liebert XDCF**

Refrigerant Charge, lb (kg)	Per Liebert XD Unit (Excludes Connector Lines to and from Liebert XD Cooling Module)
157 (71.2)	Liebert XDP/Liebert XDC
3.55 (1.61)	Liebert XDO
2.32 (1.05)	Liebert XDV
2.66 (1.21)	Liebert XDH (per circuit)
1.41 (0.64)	Liebert XDCF
4 (1.81)	Liebert XDR

**Table 3.15 System refrigerant charge for the supply and return mains**

Refrigerant Charge, lb/foot (kg/m)	Supply/Return Main Length and Diameter
0.45 (0.67)	Main supply actual length per 1-1/8" OD copper tubing
0.68 (1.01)	Main supply actual length per 1-3/8" OD copper tubing
0.28 (0.42)	Main return actual length per 2-1/8" OD copper tubing
0.43 (0.64)	Main return actual length per 2-5/8" OD copper tubing

**Table 3.16 R-134a refrigerant charge for hard-piped connector lines to and from any model Liebert XDH/Liebert XDO/Liebert XDV**

Refrigerant Charge, lb/foot (kg/m)	Hard-Piped Connector Length and Diameter
0.08 (0.12)	1/2" OD Liebert XDH/Liebert XDO/Liebert XDR/Liebert XDV supply connector actual length
0.13 (0.19)	5/8" OD copper tubing Liebert XDV supply connector actual length
0.26 (0.39)	7/8" OD Liebert XDO/Liebert XDH/Liebert XDR supply connector actual length
0.02 (0.03)	5/8" OD copper tubing Liebert XDV return connector actual length
0.04 (0.06)	7/8" OD copper tubing Liebert XDV return connector actual length
0.04 (0.06)	7/8" OD copper tubing Liebert XDH/Liebert XDO/Liebert XDR return connector actual length
0.07 (0.1)	1-1/8" OD copper tubing Liebert XDH/Liebert XDO/Liebert XDR return connector actual length

**Table 3.17 R-134a refrigerant charge for Flex Pipe connector lines to and from any model Liebert XDO/Liebert XDH/Liebert XDV/Liebert XDCF**

Refrigerant Charge, lb. (kg)	Metal Flex Pipe Connector Length
Supply Line Diameter 1/2"	
0.3 lb. (0.14)	4 ft. Flex Pipe All Liebert XD Cooling Module
0.5 lb. (0.23)	6 ft. Flex Pipe All Liebert XD Cooling Module
0.7 lb. (0.32)	8 ft. Flex Pipe All Liebert XD Cooling Module
0.8 lb. (0.36)	10 ft. Flex Pipe All Liebert XD Cooling Module
Return Line Diameter 5/8"	
0.01 lb. (0.01)	4 ft. Flex Pipe existing Liebert XDCF/Liebert XDV systems
0.02 lb. (0.01)	6 ft. Flex Pipe existing Liebert XDCF/Liebert XDV systems
0.03 lb. (0.01)	8 ft. Flex Pipe existing Liebert XDCF/Liebert XDV systems
0.03 lb. (0.01)	10 ft. Flex Pipe existing Liebert XDCF/Liebert XDV systems
Return Line Diameter 1"	
0.13 lb. (0.06)	4 ft Flex Pipe Liebert XDH/Liebert XDO/Liebert XDR supply
0.2 lb. (0.09)	6 ft Flex Pipe Liebert XDH/Liebert XDO/Liebert XDR supply
0.27 lb. (0.12)	8 ft Flex Pipe Liebert XDH/Liebert XDO/Liebert XDR supply
0.33 lb. (0.15)	10 ft Flex Pipe Liebert XDH/Liebert XDO/Liebert XDR supply

### 3.23.2 Calculating Refrigerant R134a Charge—Example

Using Table 3.14 on the previous page, Table 3.15 on the previous page, Table 3.16 above and Table 3.17 above, calculate the refrigerant charge of the individual sections of your Liebert XD system. Add the calculated charge amounts to determine the amount of R-134a refrigerant required for one system combining a Liebert XDP with Liebert XD cooling modules (Liebert XDCF, Liebert XDH, Liebert XDO, Liebert XDR and Liebert XDV). The example below combines one Liebert XDP with 20 Liebert XDV8 cooling modules.

**Table 3.18 Calculating refrigerant charge—example**

Components	Number of Units or Piping Length, feet	Pounds Per Component	Total, lb.
Liebert XDP/Liebert XDC	1	157	157
Liebert XDV8 Cooling Modules	20	2.32	46.4
Supply Main, 1-1/8"	100	0.45	45
Return Main, 2-1/8"	100	0.28	28
Liebert XDV 1/2" supply Liebert XD Flex Pipes	20	0.8	16
Liebert XDV 5/8" return Liebert XD Flex Pipes	20	0.03	0.6
		Total	293

**Table 3.19 Worksheet to calculate refrigerant charge**

Components	Number of Units or Piping Length	Pounds Per Component	Total
		Total	

Verify that the refrigerant volume of the Liebert XD system with the longest piping length is within the allowable limit. If the allowable limit is exceeded, the Liebert XDP/Liebert XDC should be moved closer to the cooling modules (refer to [Liebert XD Refrigerant](#) on page 55 for limits and related details). Another way to shorten the total pipe length is to reroute the pipe runs.

**3.24 Chilled Water Piping**

The Liebert XDP is offered only with a two-way chilled water control valve. Some applications may require the use of a pressure activated bypass valve to prevent dead-heading of the chilled water pump. This bypass valve must be specified by the engineer responsible for design of the chilled water field piping system.

**NOTICE**

Risk of particles in chilled water. Can cause equipment damage and reduced cooling.

Failure to install a strainer in the supply line to the Liebert XDP can result in damage to the unit’s heat exchanger.

Install a 20-40 mesh strainer on the chilled water supply to the Liebert XDP. The strainer is required to prevent particles in the chilled water from entering the heat exchanger of the Liebert XDP. The maximum distance of the strainer from the Liebert XDP is 10 feet (3m).



Figure 3.29 Piping access points

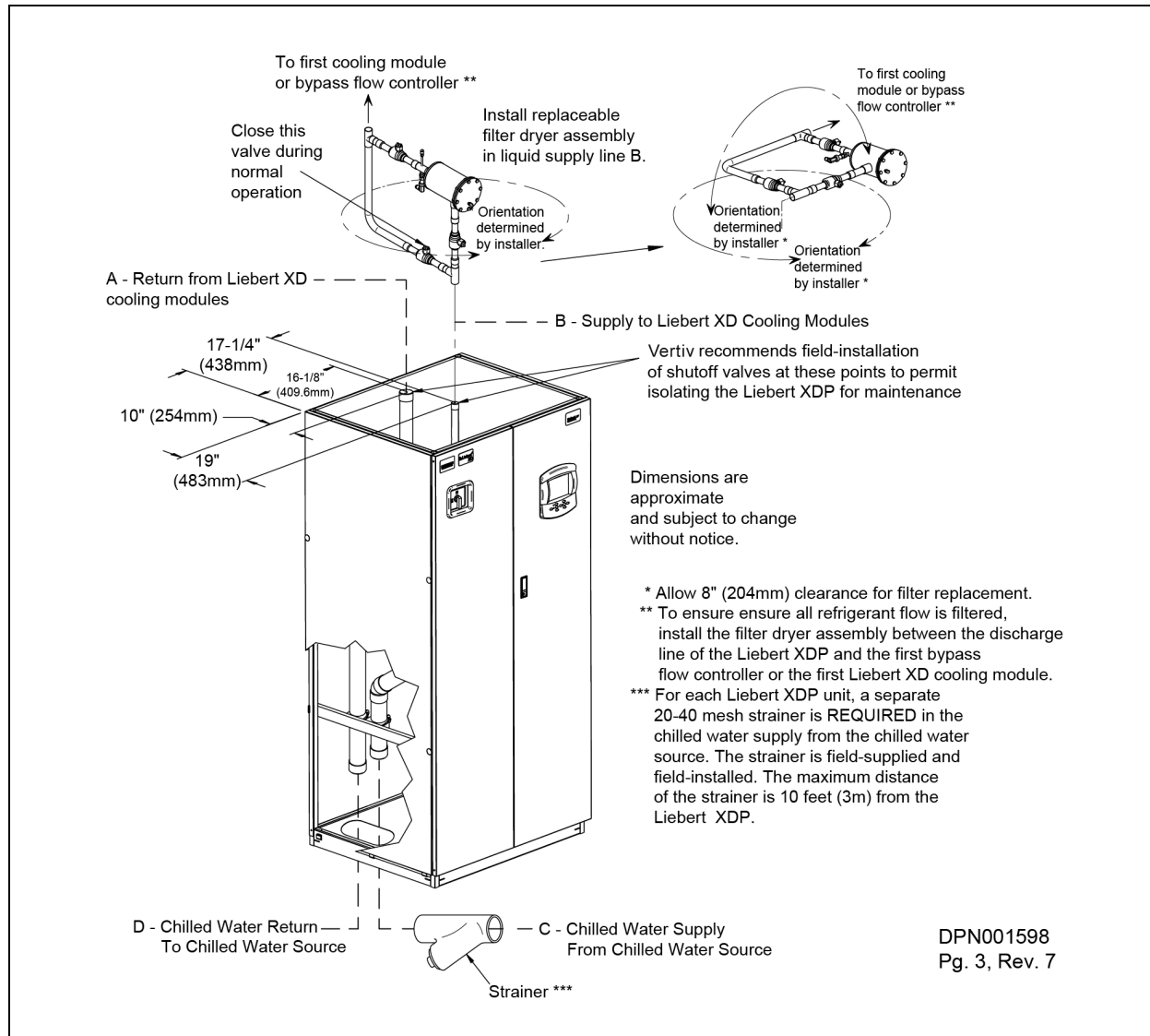

Table 3.20 Unit piping outlet connection sizes, inches, OD Cu

Model	Pipe Connection Point			
	A	B	C	D
50/60 Hz				
XDP160	2-1/8	1-1/8	2-5/8	2-5/8

Chilled water connections to the Liebert XDP are near the bottom of the unit. Refer to the Liebert XDP user manual (SL-16644) for further information. Piping is routed downward from the unit to chilled water piping under the raised floor. Connections are made using standard practices for copper chilled water piping. Field-supplied Victaulic® connections may be used to simplify installation in existing facilities. Refer to Table 9.17 on page 197 for additional information.

### 3.25 Electrical

Make all wiring and electrical connections in accordance with local and national codes. Refer to the applicable table in [Specifications and Model Number Nomenclature](#) on page 183 regarding wire size and circuit protection requirements. Refer to electrical schematic when making connections.

### 3.26 Temperature/Humidity Sensor Locations

The display panel sensor and Liebert iCOM sensor (shipped loose) must always be installed in the conditioned space. The display panel sensor and Liebert iCOM sensor may be mounted on the Liebert XDC/XDP's front door if the unit is located in the area that it conditions.

The remote temperature / humidity sensor for the Liebert XDP and the Liebert XDC should be installed in the higher-temperature portion of the cold aisle where the Liebert XD modules are located. Alternatively, it can be placed on the return air side of the primary air mover, such as a Liebert DS, in the room if it represents the conditions where all the Liebert XD cooling modules are located. It should not be installed where ambient air might cause false readings, for example, near unsealed doors, windows and similar areas.

### 3.27 Connecting Liebert XDP and Liebert XD Cooling Modules in a CANbus Network

A Controller Area Network (CAN) is a specialized internal communication network. It allows the Liebert XDP and the Liebert XD smart modules to communicate without a host computer. Networking a Liebert XDP with smart modules enables the smart modules to be controlled and monitored from the Liebert XDP.

The Liebert XD smart modules CANbus is to be networked only to the Liebert XDP that is supplying coolant to the smart modules.

**Figure 3.30 Liebert XD system with CANbus**



#### 3.27.1 CANbus Cables

The Liebert XDP may be connected to smart modules with CANbus cables. The shielded cable consists of three pairs of twisted wires with a six-pin RJ-12 connector.

Figure 3.31 CANbus cable wiring

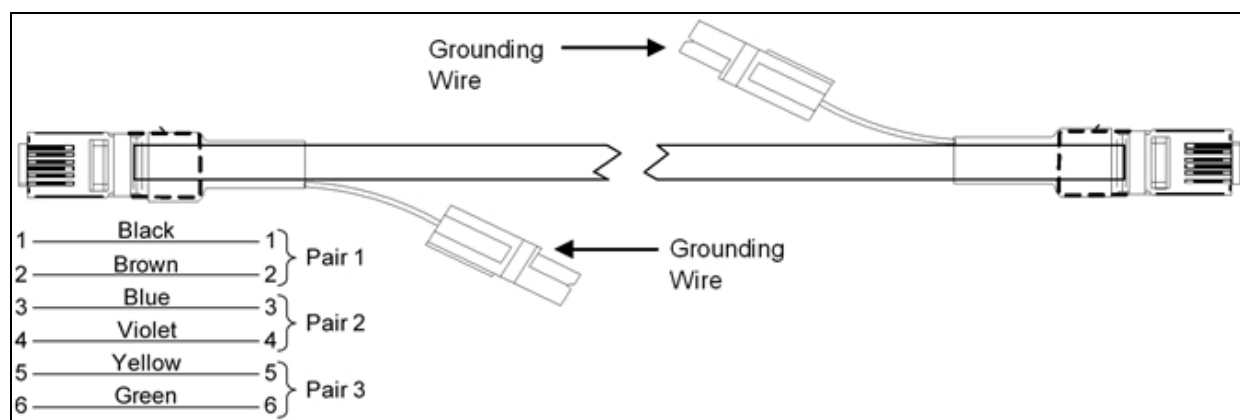

Table 3.21 CANbus cable part numbers

Length ft (m)	Part #
3 (0.9)	300157G10
6 (1.8)	300157G1
10 (3.0)	300157G2
15 (4.6)	300157G11
20 (6.1)	300157G3
30 (9.1)	300157G4
60 (18.3)	300157G5
90 (27.4)	300157G8
120 (36.6)	300157G7
150 (45.7)	300157G8

Plan wiring runs for U2U communication when designing the layout of the conditioned space. In addition to following general good wiring practices, take these precautions:

- Keep control and communication cables away from power cables to prevent electromagnetic interference.
- Do not bend cables to less than four times the diameter of the cable.
- Do not deform cables when securing them in bundles or when hanging them.
- Keep cables away from devices that can introduce noise into them, such as machines, fluorescent lights and electronics.
- Avoid stretching cables; tension when pulling cables should not exceed 25 pounds (11kg) of pulling tension.
- Do not secure cables with any method that might damage them. Use approved hangers, such as those for telephone wire or RG-6 coaxial cable, available at most hardware stores.

### 3.27.2 CANbus Cable Length in a Network

The maximum total length of cable that can be used in a CANbus network differs by the type of Liebert XD cooling module as shown in Table 3.22 on the next page.

**Table 3.22 Allowable total CAN cable length**

Module	Allowable Total CAN Cable Length, ft (m)
Liebert XDV8	580 (177)
Liebert XDV10	580 (177)
Liebert XDO16	590 (180)
Liebert XDO20	590 (180)
Liebert XDH20	580 (177)
Liebert XDH32	585 (178)

\*The internal CANbus cable within the Liebert XD module and the remote sensors has been accounted for.

**Figure 3.32 Single daisy chain of Liebert XDO smart modules in CANbus network**

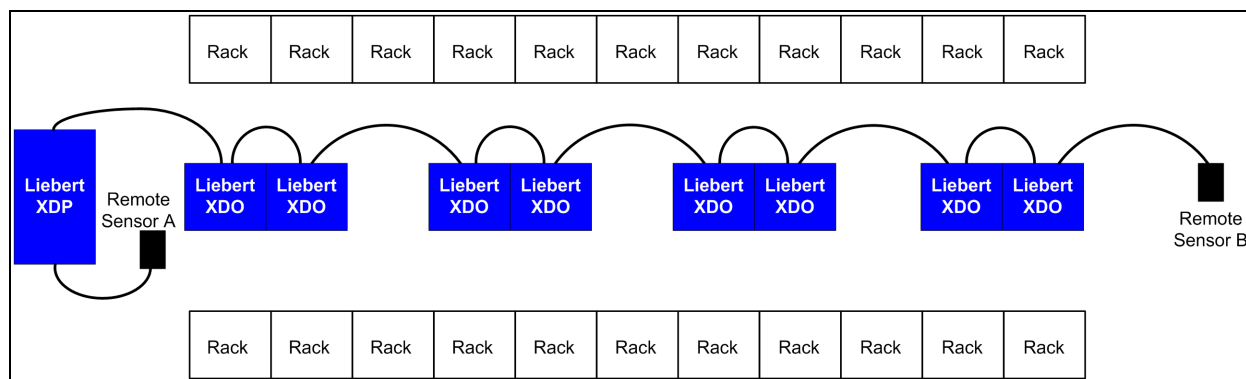

**Table 3.23 Cumulative cable length in Figure 3.32 above**

Cable Segments	Length of Each ft. (m)	Cumulative Length ft. (m)
14	6 (1.8)	84 (25.6)
1	20 (6)	20 (6)
1	30 (9.1)	30 (9.1)
Combined cable length		134 (40.8)

The cumulative length of cable used in the example in Figure 3.32 above is 134 ft. (40.8m), far shorter than the maximum allowable cable run of 580 ft. (177m) for Liebert XDV10 modules.

### 3.27.3 Remote Sensor Placement Within the CANbus

Two remote sensors are shipped with the Liebert XDP. One shielded CANbus cable is provided with each sensor. Sensor A is to be connected to the directly the Liebert XDP. Sensor B is to be connected to the CANbus within the smart module chain. This can be at the end of the chain as shown in Figure 3.33 on the facing page. For proper placement within the room, see [Temperature/Humidity Sensor Locations](#) on page 60.

**Figure 3.33** Sensor at the end of daisy chain of Liebert XDO smart modules in CANbus network

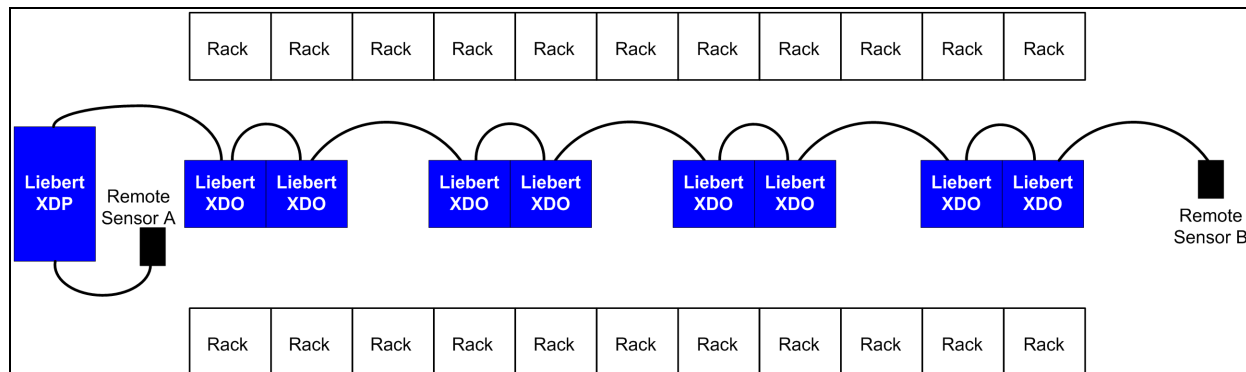

Sensor B can be placed in the middle of the daisy chain as shown in Figure 3.34 below; however, the additional cable length must be subtracted from the allowable length.

**Figure 3.34** Sensor within the daisy chain of Liebert XDV smart modules in CANbus network

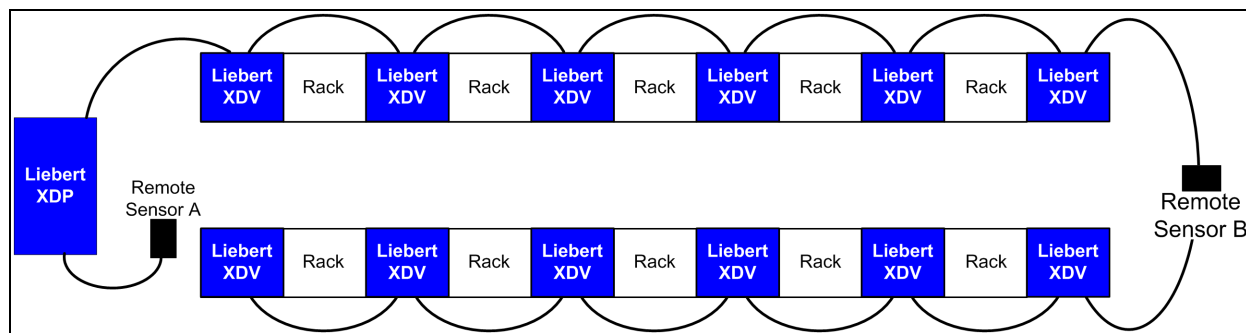

The modules can also be split into two chains as shown in Figure 3.35 below.

**Figure 3.35** Dual daisy chain of Liebert XDV smart modules in CANbus network

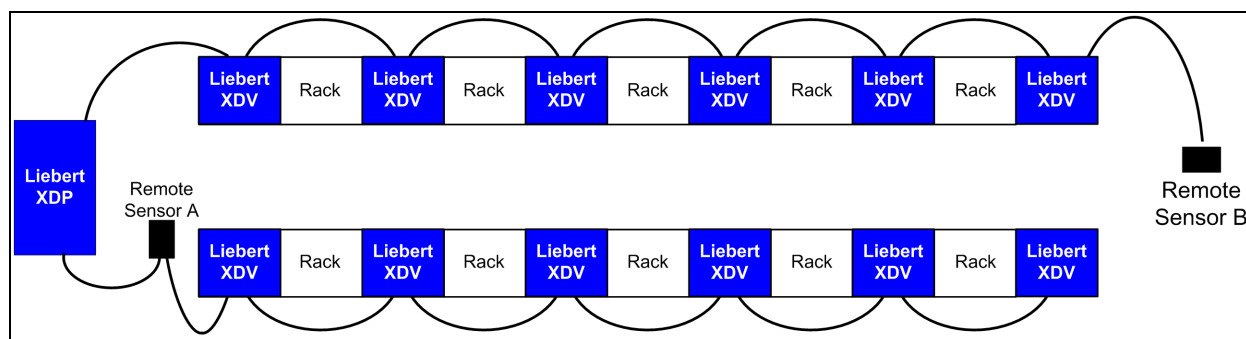

The sensors can also be isolated in an independent daisy chain, see Figure 3.36 on the next page.

Figure 3.36 Independent smart module and sensor daisy chains in CANbus network

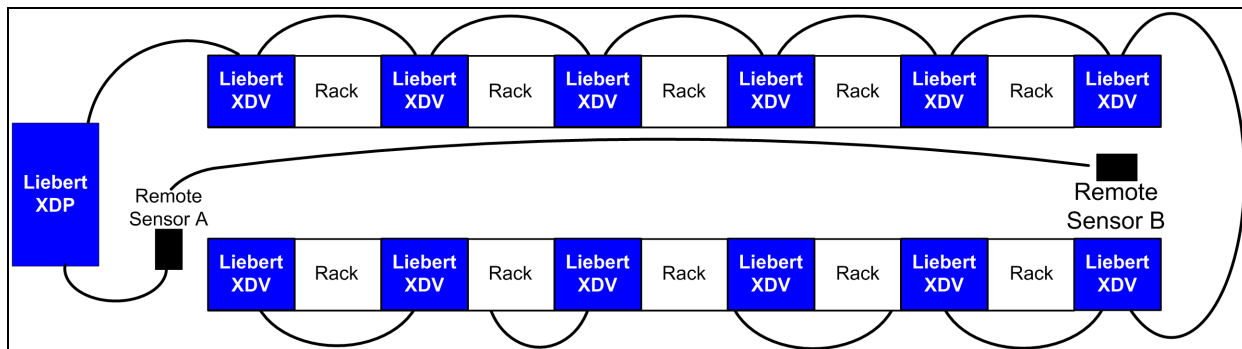

## 4 LIEBERT XD COOLING MODULES—LIEBERT XDCF, LIEBERT XDH, LIEBERT XDO, LIEBERT XDR AND LIEBERT XDV

### 4.1 Liebert XDCF Standard Features

The Liebert XDCF is a self-contained module designed to cool Egenera’s BladeFrame EX cabinets and equipment without exhausting heat into the room.

Upper and lower modules may be mounted on the rear of an Egenera BladeFrame. Liebert XDCF modules use R-134a refrigerant. When attached to a fully loaded BladeFrame EX rack, each Liebert XDCF module has a nominal cooling capacity of 10kW (2.8 tons; 34,000 BTUh). Performance is based on:

- Entering fluid temperature—55°F (12.8°C) and
- Dew point—50°F (10°C) or lower.

Liebert XDCF modules consist of a sheet-metal frame, coil and filter dryer. It has no moving parts and needs no electricity.

The Liebert XDCF system (see Figure 4.1 below) consists of:

- Liebert XDCF Modules—upper and lower models are available
- Flex Pipe—connects Liebert XDCF modules to supply and return piping
- Liebert XD Piping—delivers pumped R-134a refrigerant through flexible piping
- Liebert XDP or Liebert XDC—supplies R-134a refrigerant to Liebert XDCF modules

(see Liebert XDP or Liebert XDC user manual for required chiller or drycooler)

Figure 4.1 Liebert XDCF generic piping layout

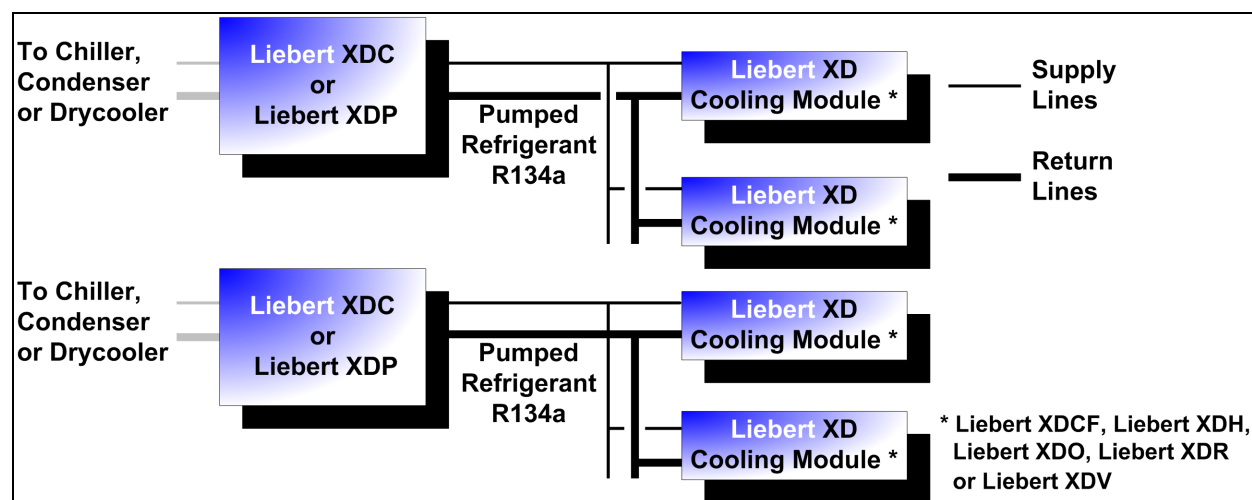

### 4.2 Liebert XDCF Mechanical Considerations

The Liebert XDCF is engineered to fit on the rear of the Egenera BladeFrame enclosure. Figure 4.2 on the next page illustrates the module’s dimensions and the location of pipes. Figure 4.3 on page 67 shows the attachment positions of each module.

Figure 4.2 Overall dimensions

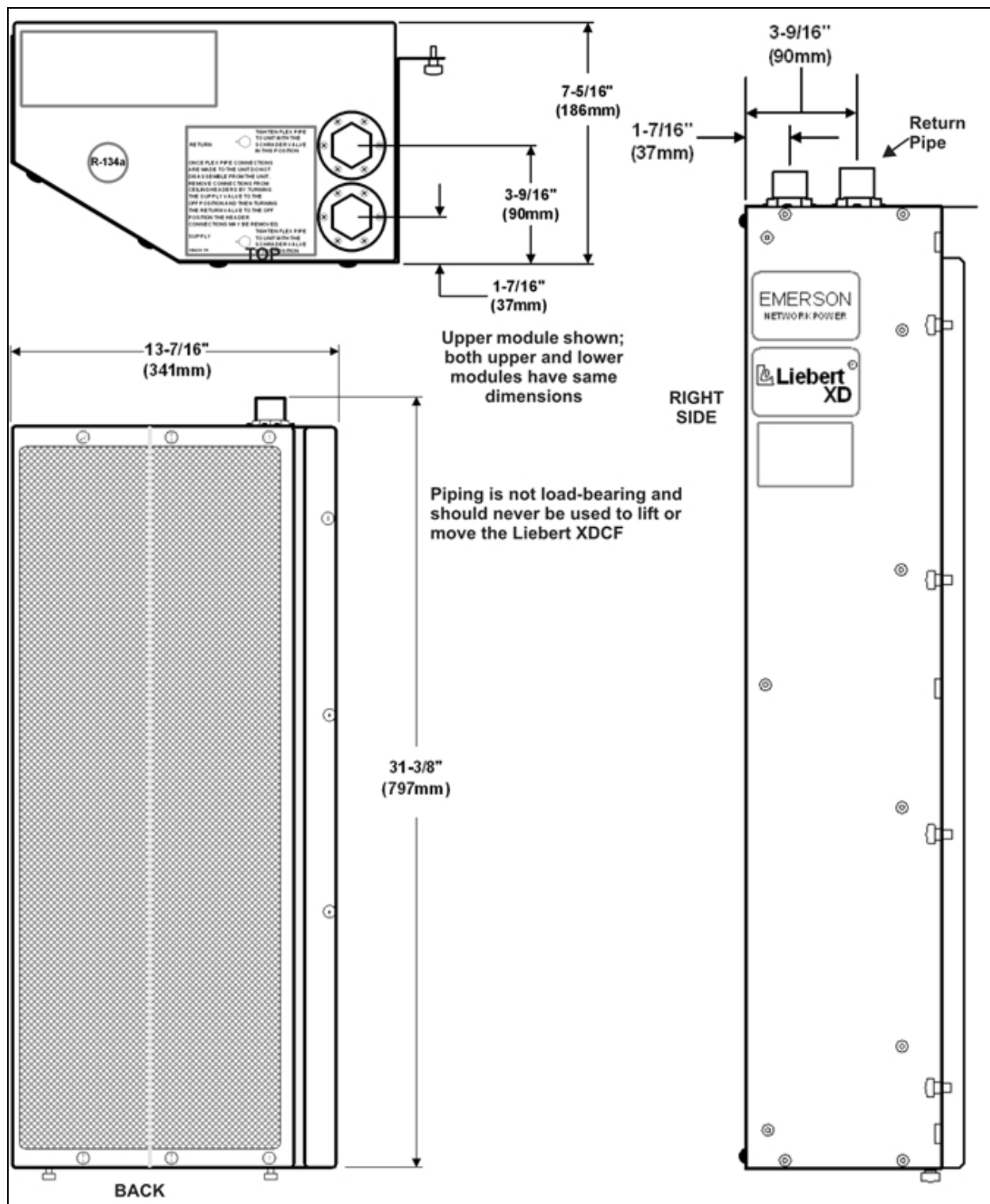



### 4.3 Liebert XDCF Installation Considerations

No cutting or drilling is required to attach the modules to the rear of the Egenera BladeFrame cabinet. All mounting holes, slots and pins required are fabricated at the factory.

Liebert XDCF modules attach beside the power modules on the rear of the Egenera BladeFrame (see Figure 4.3 below).

**Figure 4.3 Liebert XDCF module mounting locations**

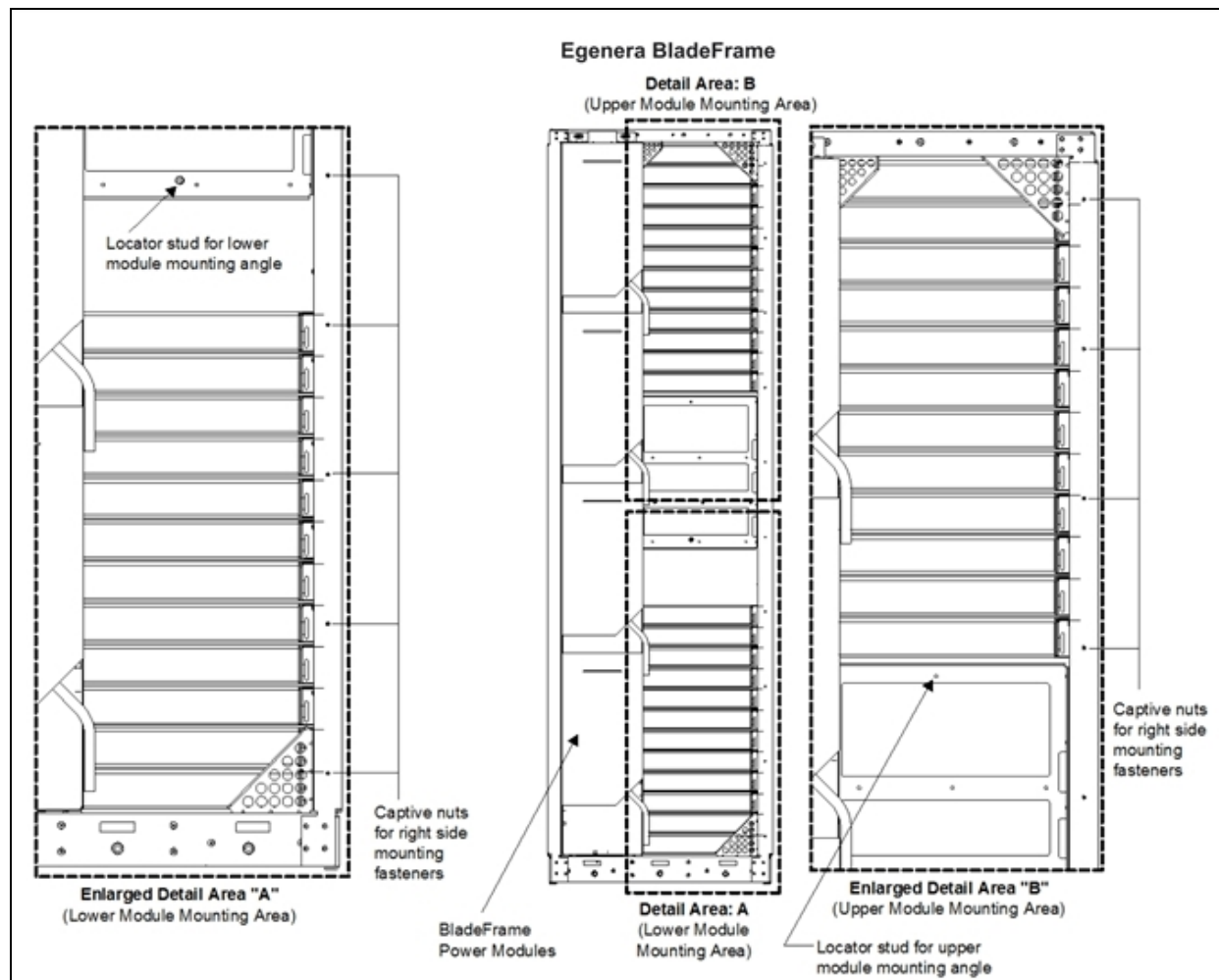

### 4.4 Liebert XDCF Piping Connection Methods and Points

The assembly and connection means used for piping in the Liebert XD system are the same as those used in conventional refrigeration systems. Observe all standard practices during installation and startup to prevent damage and contamination.

Supply piping connection is 1/2" OD copper pipe, and return piping connection is 5/8" OD copper. Both supply and return fittings are one-shot connections. These fittings contain pressurized R-134a refrigerant inside the Liebert XDCF.

Risk of explosive discharge. Can cause death, injury and equipment damage.

**! WARNING! Do not disconnect one-shot connections after they have been connected. Disconnection will release pressurized R-134a refrigerant from the Liebert XDCF.**

The Liebert XDCF has supply and return piping access on the top of each module.

#### 4.4.1 Header System—Liebert XDCF

The Liebert XDCF module system requires use of the Liebert XD prefabricated piping assembly or port kit. The prefabricated piping is compatible with the flex pipe required to attach to the Liebert XDCF modules.

**Figure 4.4 Liebert XDCF supply and return piping access points**

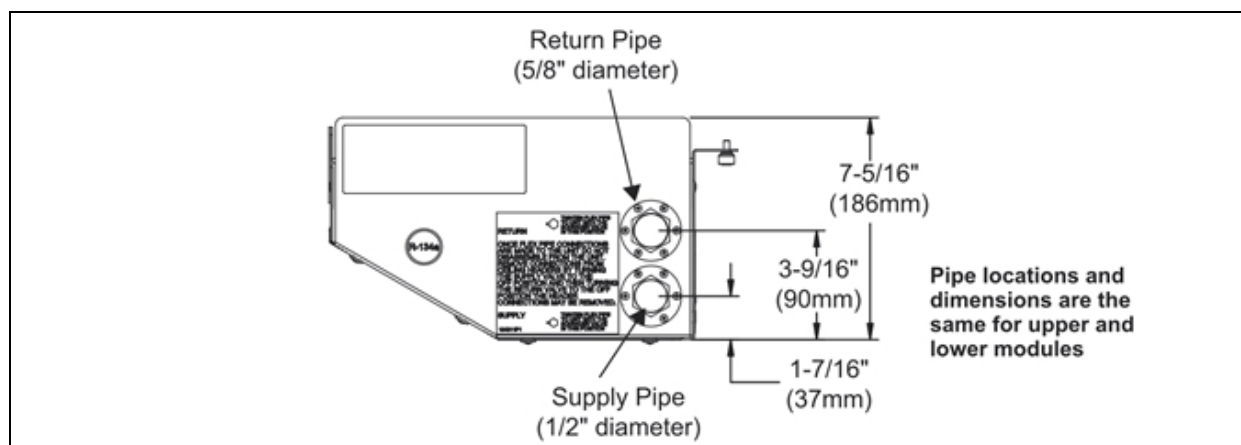

#### 4.5 Liebert XDH Standard Features

- **Dual Refrigeration Circuits**—Each Liebert XDH has two refrigeration circuits, one in the upper half of the module and one in the lower half. Dual refrigeration circuits permit altering cooling levels in response to server room conditions. The dual refrigeration circuits permits interlaced connection of two refrigerant sources to enhance system reliability.
- **Dual Power Cords and Power Inlets**—The Liebert XDH is supplied with two (2) detachable power cords 10 ft (3m) long that attach to two IEC power inlets on the rear of the module. Each power cord has a NEMA 5-15P (IEC 320-C14) plug at the opposite end. The dual power cords allow the module to be powered by two separate power sources. If the secondary power cord is connected to a UPS, the Liebert XDH's fans will continue to operate if utility power fails.
- **Top Piping Access**—The Liebert XDH has supply and return piping access on the top of each module. Supply piping connection is 1/2" OD copper pipe, and return piping connection is 7/8" OD copper.
- **Corner Stabilizers**—A stabilizer in each corner permits rolling the Liebert XDH with greater ease and less chance of tipping.
- **Air Diffusers**—Two diffusers, one on the upper half of the module and one on the lower half, enhance flow of cooling air. Uni-directional and bi-directional diffusers are available.

## 4.6 Optional Features—Liebert XDH

- **Smart Module**—Smart modules will allow remote shutdown, fan failure alarms and automatically switching the second fan bank On and Off. The controls save energy by permitting the module to turn one fan in each fan bank Off based on the supply and return temperature. Liebert XD smart modules are able to provide alarm conditions such as fan failure or condensate detection at the Liebert XDP display via CANbus communication. For electrical connection details, refer to the Liebert XDH user manual, SL-17210, available on the Vertiv web site: [www.VertivCo.com](http://www.VertivCo.com)
- **Refrigerant Precharge**—The Liebert XDH can be precharged with refrigerant. The module will have one-shot fittings and will be pressurized. The one-shot Liebert XD Flex Piping will also be precharged with refrigerant.
- **Field-Installed Flexible Piping** (for use with prefabricated piping assemblies)—Field-installed flexible piping kits are available in lengths of 4, 6, 8 and 10 feet (1.2, 1.8, 2.4 and 3 meters). Connection style to the module end may be straight or 90 degrees with one-shot style couplings or removable couplings. Flex pipes with one-shot connections will have pressurized R134a. Flex pipes with removable connections will have a low pressure nitrogen charge. Connection to the prefabricated piping assembly is with a threaded coupler. For information on acquiring the correct kit for your installation, refer to DPN000780, available by calling 1-800-LIEBERT and from your local Vertiv representative.
- **Tie-Down Bracket**—An optional tie-down bracket may be installed on the Liebert XDH to secure it in the row. The bracket keeps space between the Liebert XDH and adjacent equipment constant, preventing vibration.

Figure 4.5 Liebert XDH dimensions

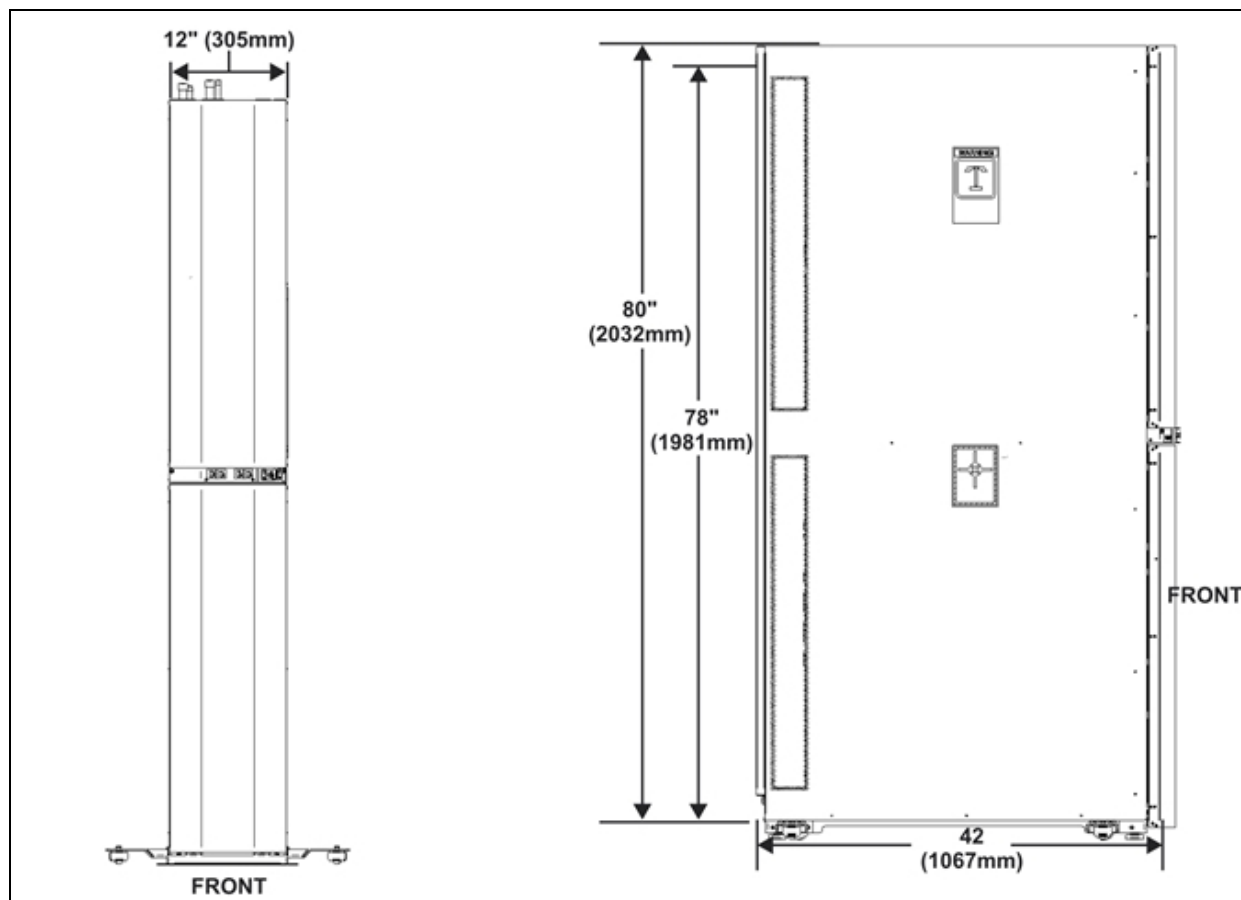
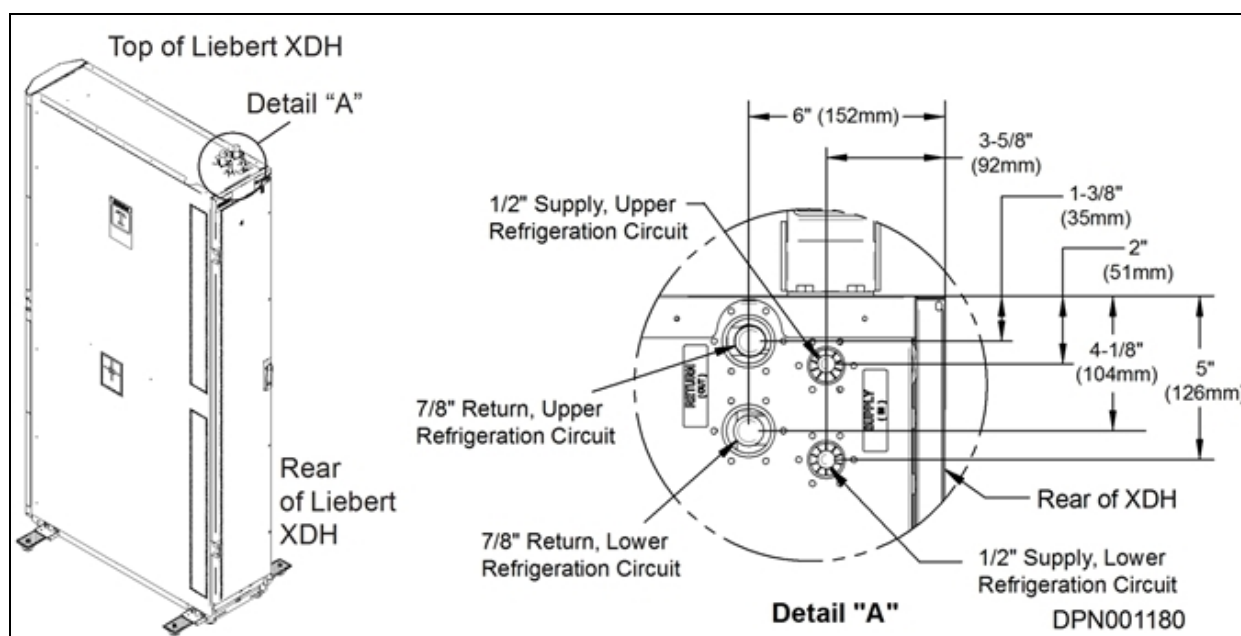

Figure 4.6 Supply and return piping connections—Liebert XDH



## 4.7 Connecting High-Voltage Wiring—Liebert XDH

The Liebert XDH requires single-phase power for normal operation. The module ships with two power cords, each 10 feet (3m) long with NEMA 5-15 plugs, which connect to common, three-prong outlets (see Figure 4.7 below and Figure 4.8 below).

Figure 4.7 Basic Liebert XDH electrical connections

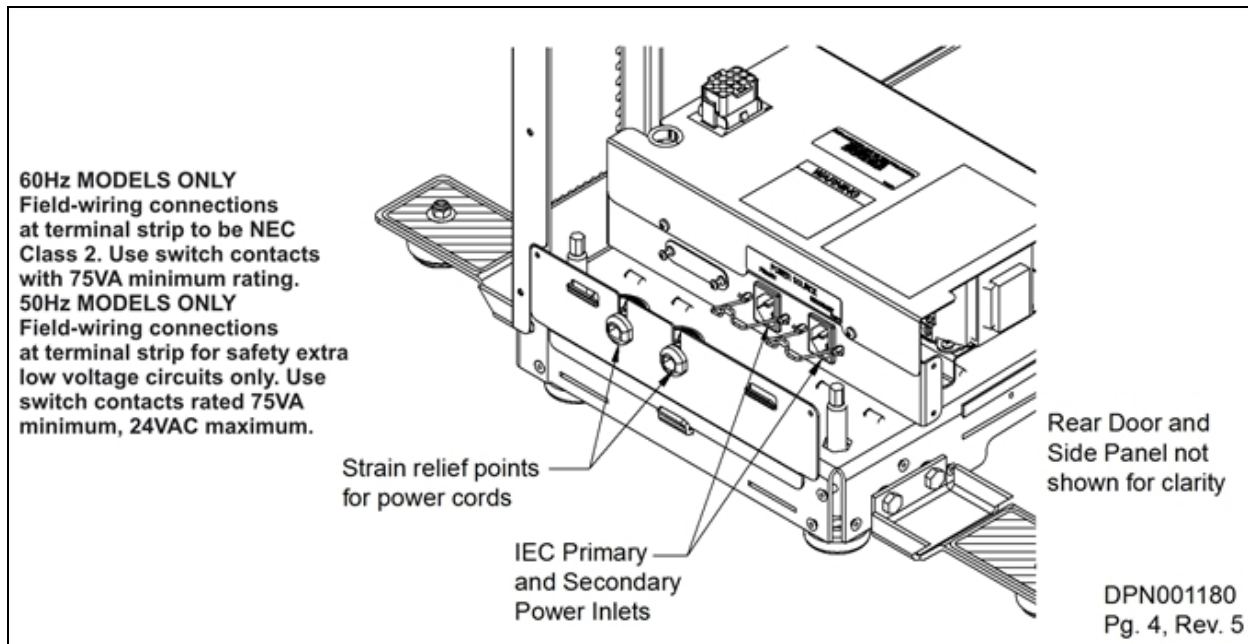
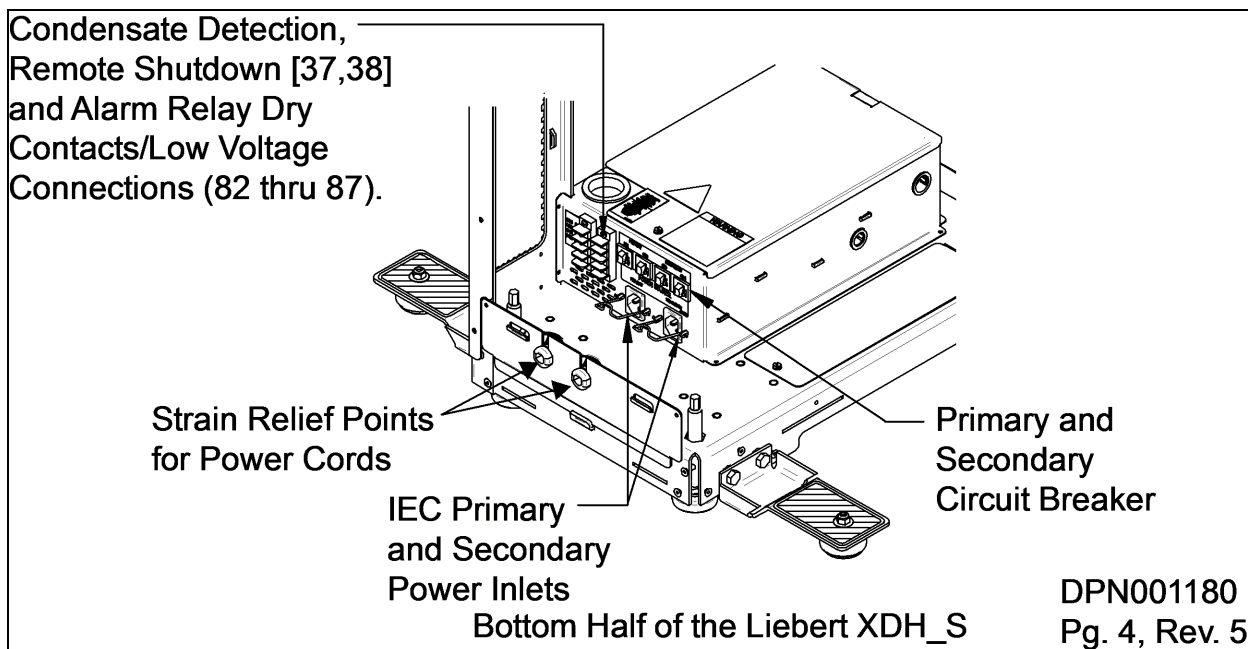

Figure 4.8 Smart Liebert XDH electrical connections



## 4.8 Connecting Low-Voltage Wiring—Liebert XDH Smart Modules

Low-voltage connections are available only on the Liebert XD smart module. The low-voltage connections for Liebert XDH smart modules are in the rear of the modules. There are two connection locations, one for the lower bank of fans and one for the upper bank of fans. The power connections are shown in Figure 4.9 below; the communication ports are on the rear left side of the Liebert XDH.

These dry contacts can to be connected to a monitoring unit, such as Liebert SiteScan®. Make connections on these modules according to site-specific drawings. The module must be installed in accordance with national and local wiring regulations.

Terminal block connections 37, 38 and 82 through 87 can be connected to a monitoring unit, such as Liebert SiteScan. The remote shutdown, condensate detection alarm, and fan failure alarms operate independently of each other.

- Contacts 37 and 38 are for remote shutdown.
- Contacts terminals 82, 83 and 84 are activated by the condensate detection alarm.
  - T82 is used for normally open contact closure requirements.
  - T83 is common.
  - T84 is used when normally closed contact closure is required.
- Contacts terminals 85, 86 and 87 are activated by the fan failure alarm.
  - T85 is for normally open contact closure requirements.
  - T86 is common.
  - T87 is used when normally closed contact closure is required. The condensate detection alarm and the fan failure alarm operate independently of each other.
- P66 and P67 are CAN bus ports.

**Figure 4.9 Low-voltage connections—Liebert XDH smart module**

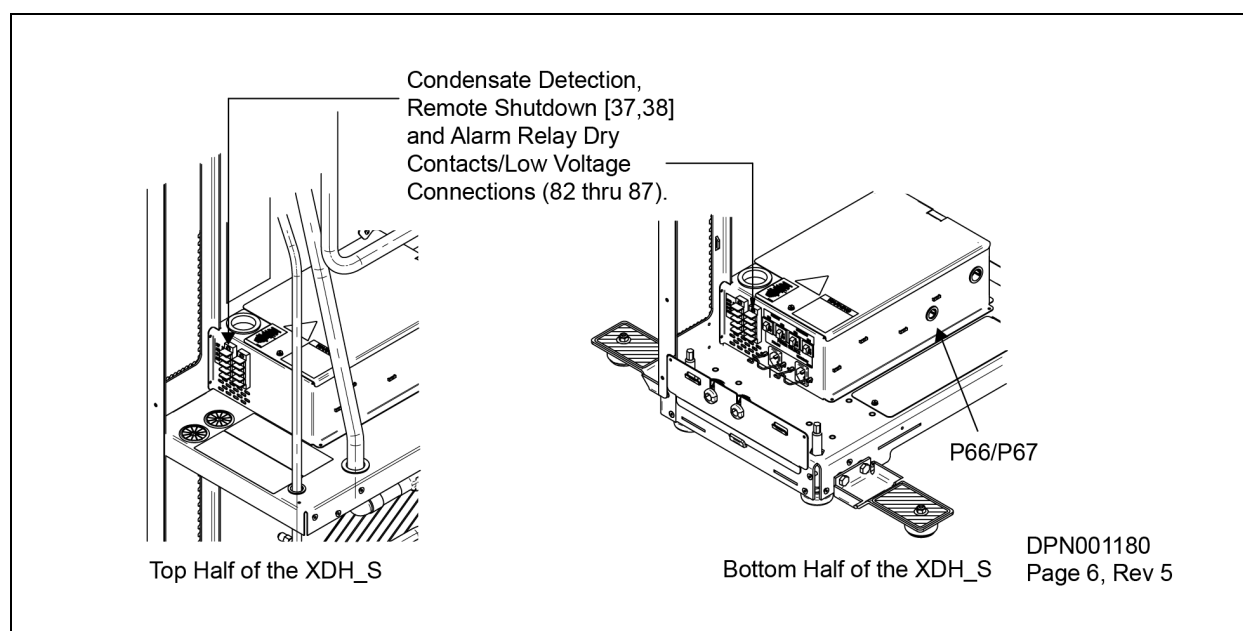

## 4.9 Liebert XDO Standard Features

- **Micro Channel Heat Exchanger**—The Liebert XDO module includes two all-aluminum micro channel heat exchangers.
- **Fan**—Air is drawn in the sides of the module through the heat exchangers and is discharged by the fan to the area below—The Liebert XDO fan tray hinges down to allow access to replace or service all electrical components.
- **Internal Mounting**—The Liebert XDO module is typically suspended from the overhead building structure by inserting field-supplied threaded rods into the internal mounting brackets.

## 4.10 Optional Features Liebert XDO

- **Refrigerant Pre-Charge**—The Liebert XDO can be precharged with refrigerant. The module will have the one-shot fittings and be pressurized. The one-shot Liebert XD Flex Piping will also be precharged with refrigerant.
- **Field-Installed Flexible Piping** (for use with prefabricated piping assemblies or port kits)—Field-installed flexible piping kits are available in lengths of 4, 6, 8 and 10 feet (1.2, 1.8, 2.4 and 3 meters). Connection style to the module end may be straight or 90 degrees with one-shot connections. Flex pipes with one-shot connections will have pressurized R134a. Connection to the prefabricated piping assembly is with a threaded coupler. For information on acquiring the correct kit for your installation, refer to DPN000780, available by calling 1-800-LIEBERT and from your local Vertiv representative.
- **External Mounting Brackets**—The Liebert XDO module can be suspended by external mounting brackets that are attached to the front and rear panels of the module. The external mounting brackets are optional ship-loose items.
- **Smart Modules**—The Liebert XDO is available with an optional factory-installed control board. A Liebert XDO smart module will allow remote monitoring, shutdown, fan failure alarms, condensate detection and automatically cycling the fan On and Off as the heat load requires. Liebert XD smart modules are able to provide alarm conditions such as fan failure or condensate detection at the Liebert XDP display via CANbus communication.
- **Lighting Fixture**—Field-installable lighting fixtures are available in two voltages, 120V and 277V. The lighting fixture may be attached to the bottom of the light panel to the left and right of the fan. Each fixture consists of housing, reflector, ballast and diffuser. Fixtures are compatible with standard 48" fluorescent bulbs. Bulbs are not included.

Figure 4.10 Dimensional data—Liebert XDO hard-piped modules

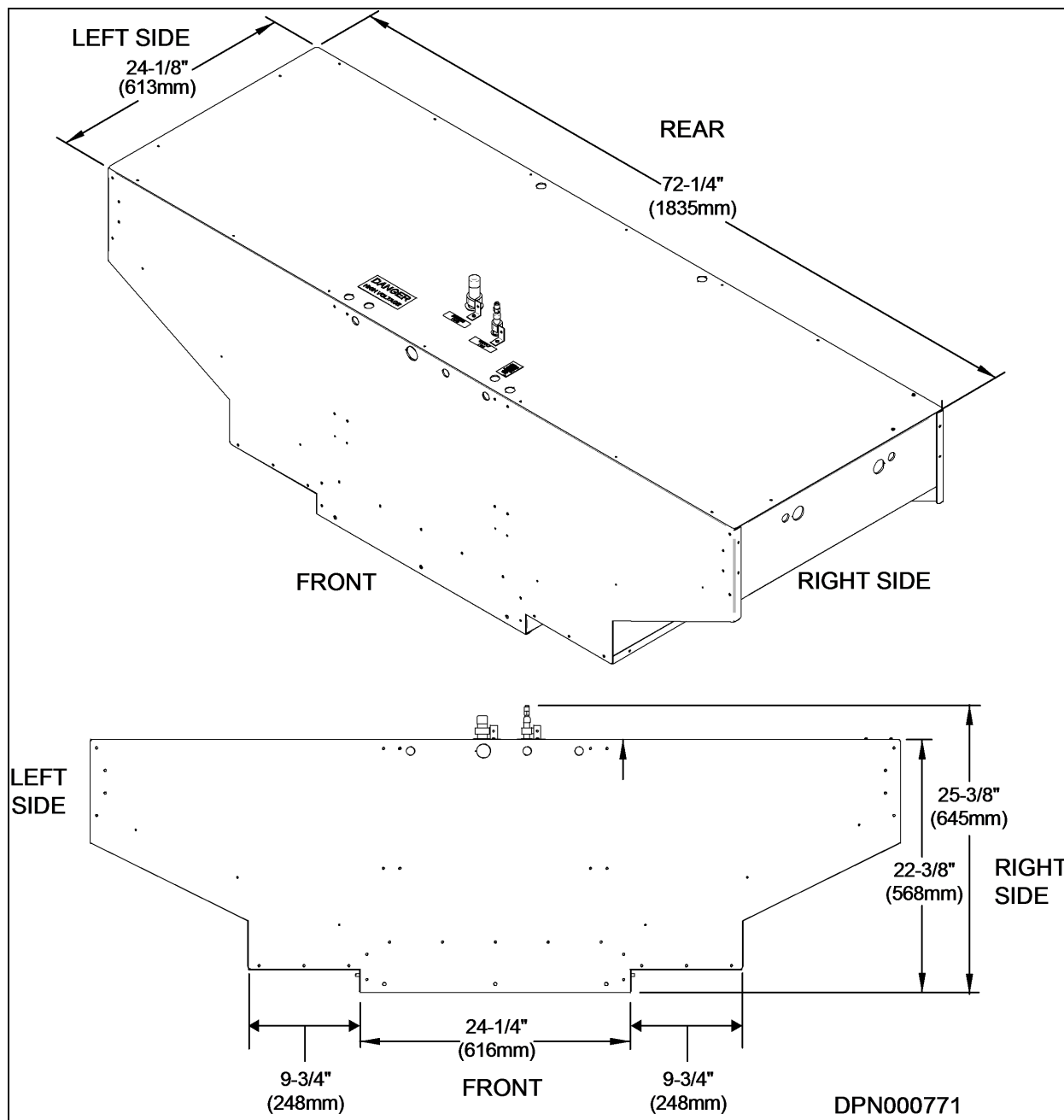



Figure 4.11 Dimensional data—Liebert XDO with pre-charged option

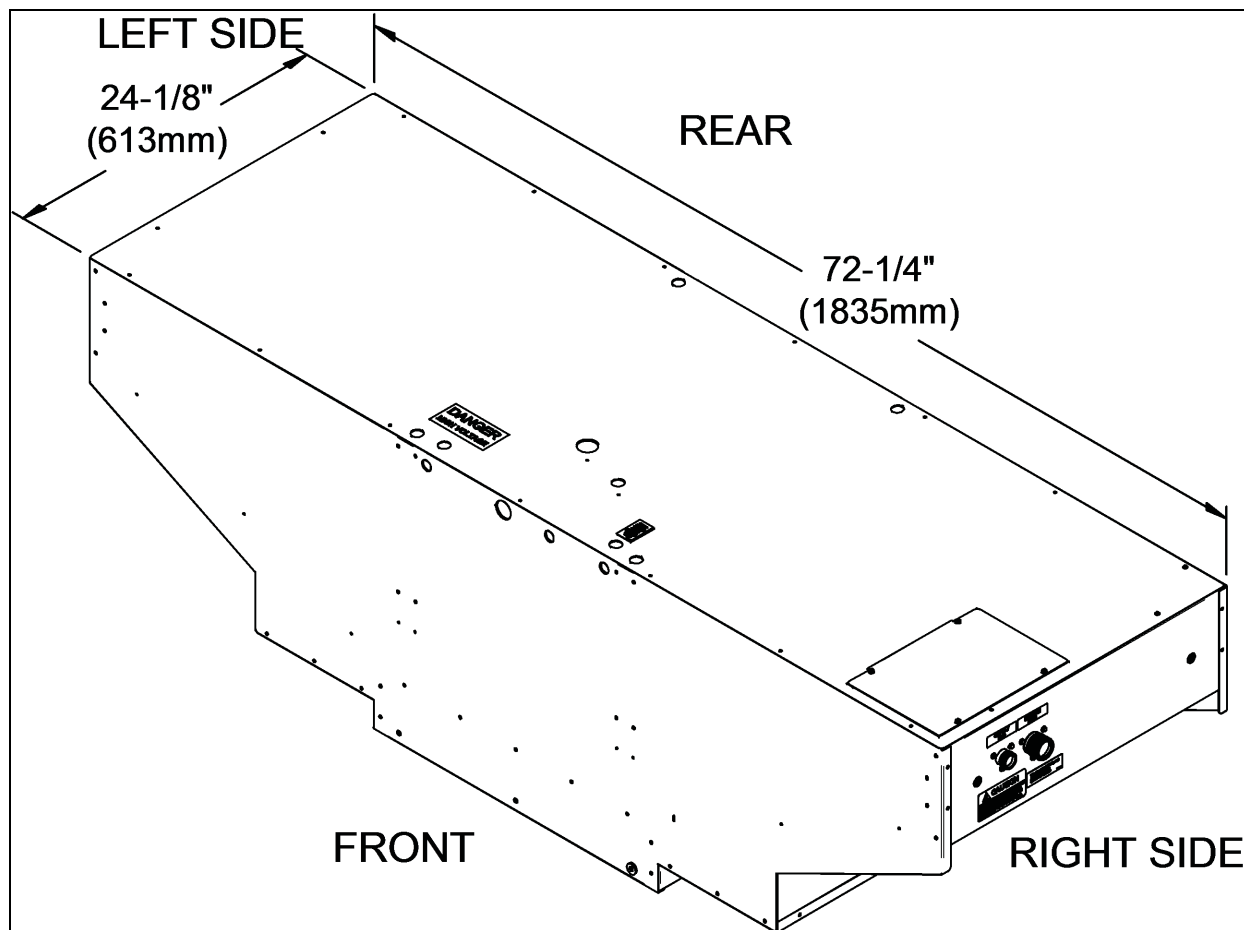

Figure 4.12 Liebert XDO internal mounting location

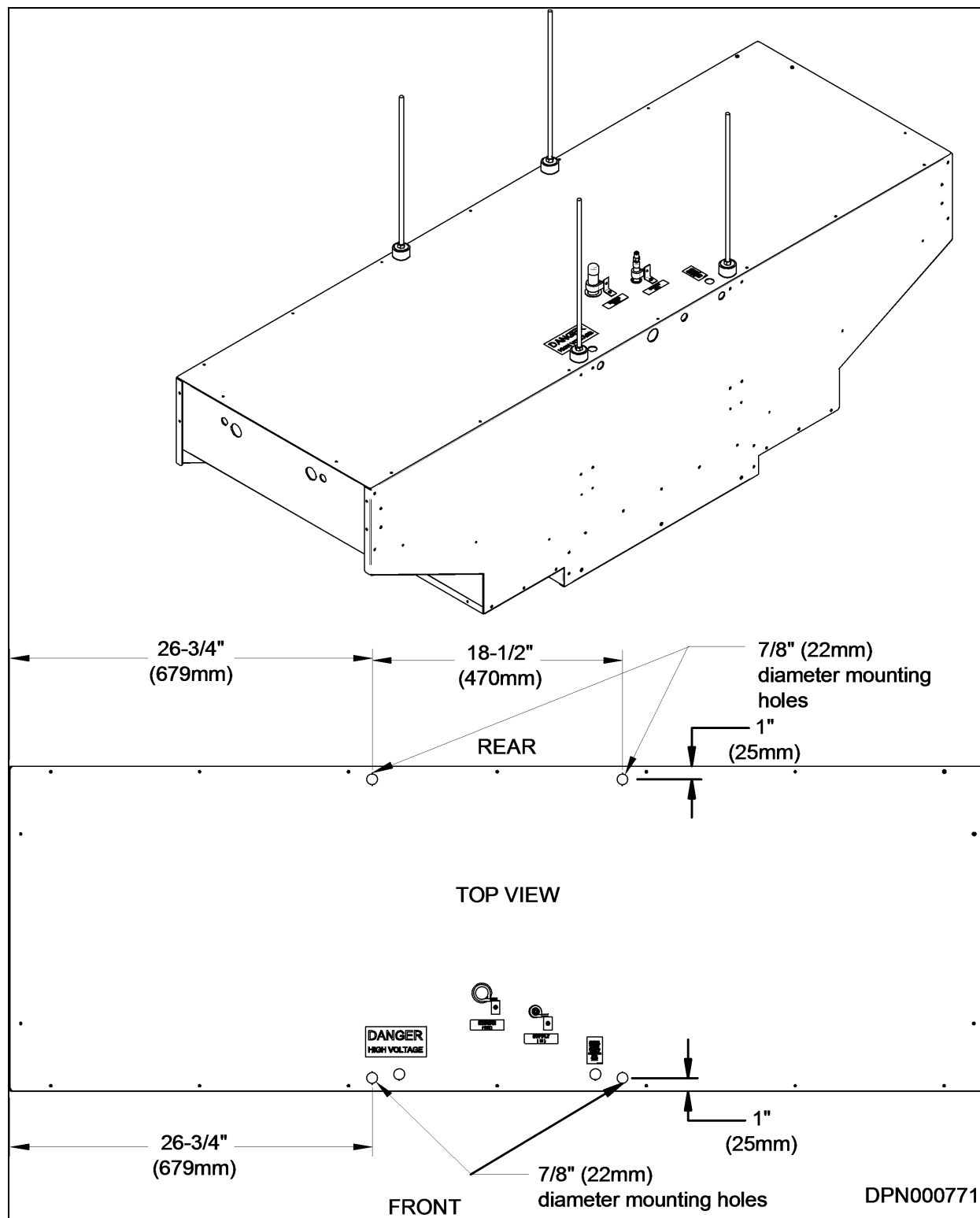

Figure 4.13 Top and front electrical access points and terminal block—standard Liebert XDO modules

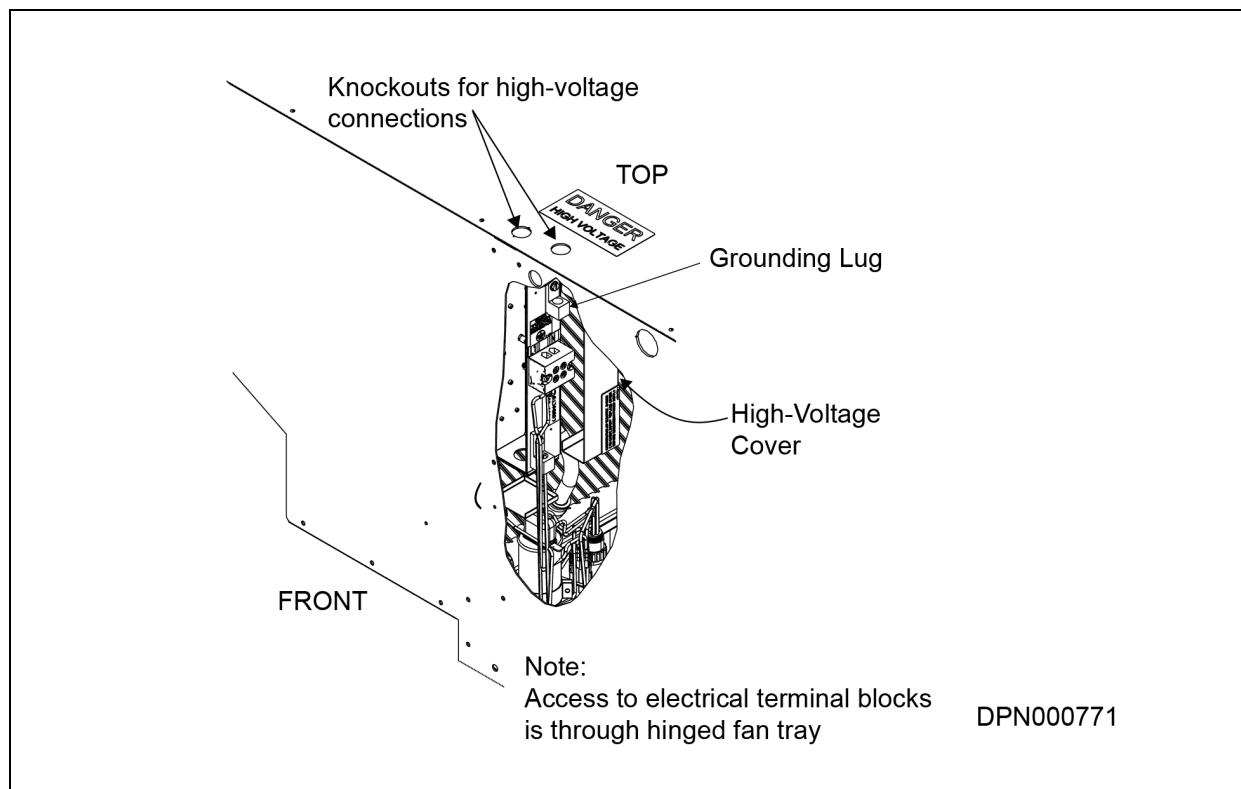

Figure 4.14 High-voltage terminal block and connection locations—standard Liebert XDO modules

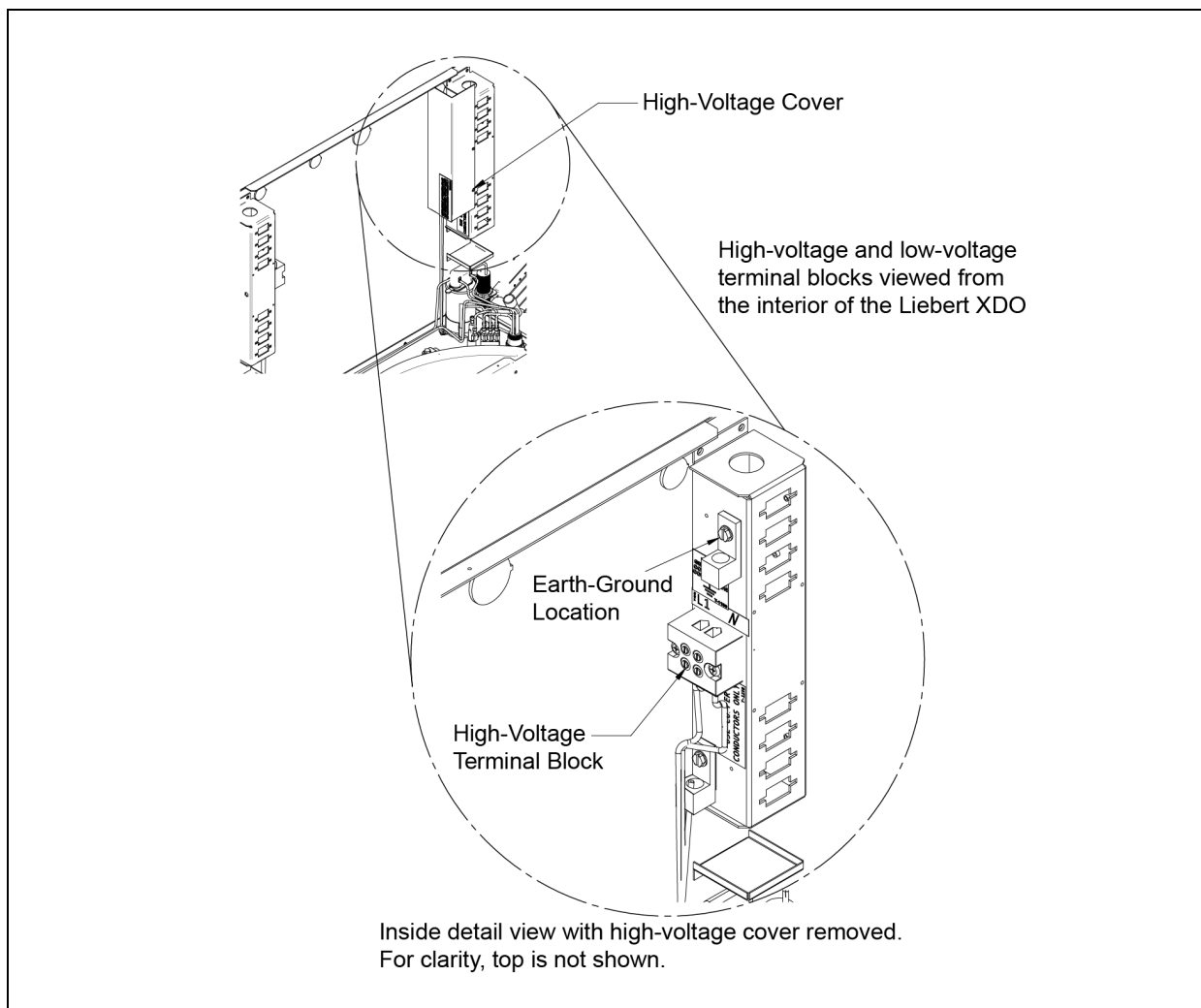

Figure 4.15 Top and front electrical access points—Liebert XDO smart modules

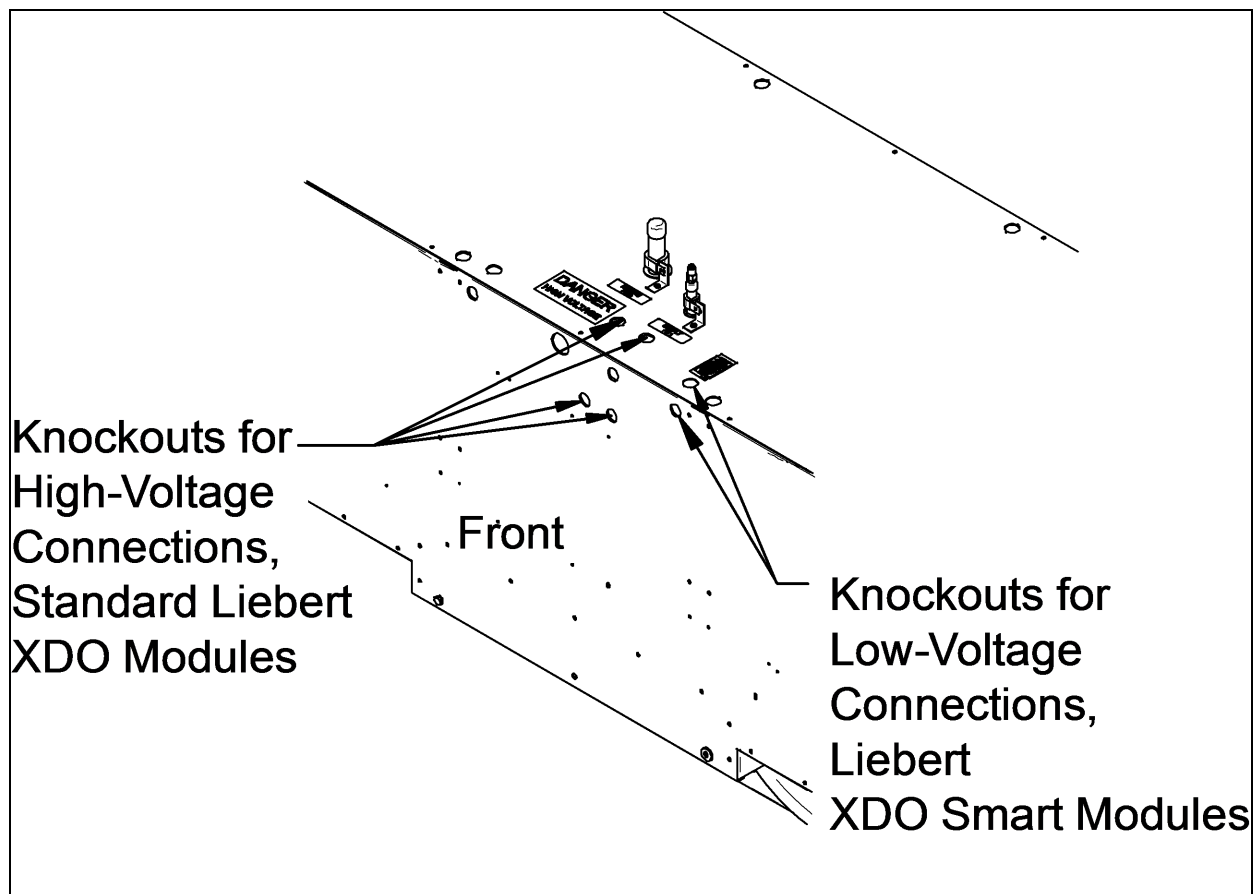
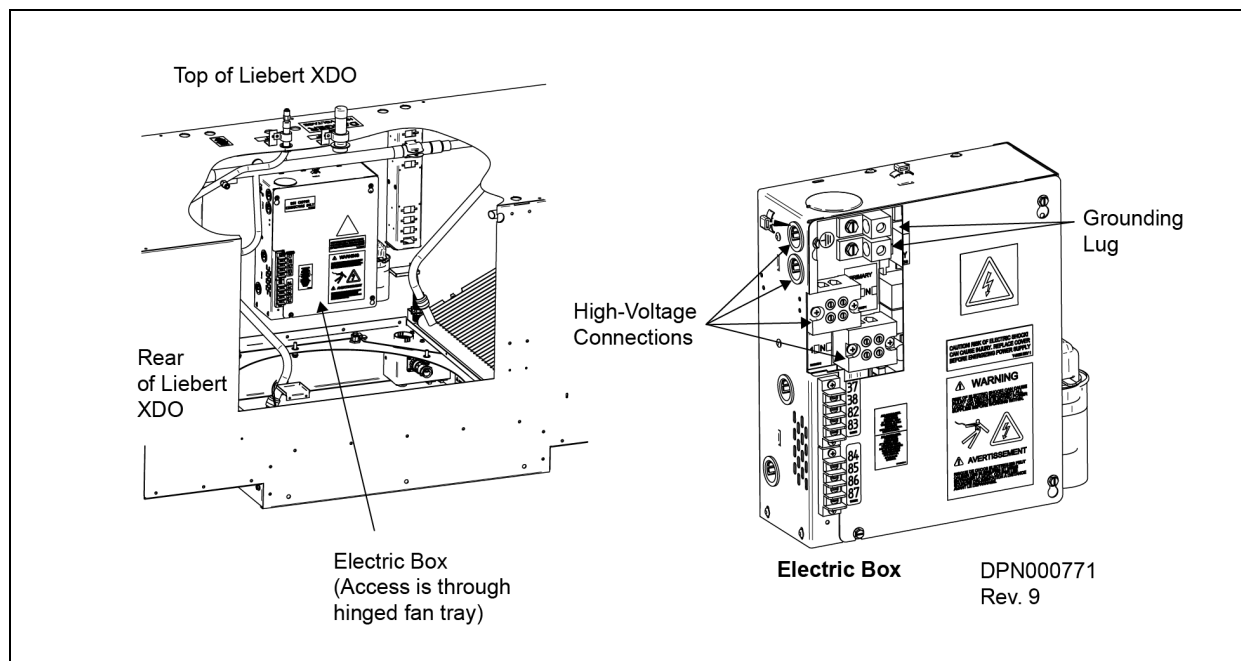

Figure 4.16 High-voltage terminal block connection locations—Liebert XDO smart modules



## 4.11 Low-Voltage Wiring—Liebert XDO Smart Modules

Low-voltage connections to the Liebert XDO are available only on smart modules.

Viewing the Liebert XDO from the front or from above, the low-voltage terminal block is on the right side of the module (see Figure 4.17 on the facing page). Make low-voltage connections on these modules according to site-specific drawings. The module must be installed in accordance with national and local wiring regulations.

For Liebert XDO smart modules, the low-voltage connections are on the electric box inside the Liebert XDO. Knockouts for the low-voltage connections are on the front of the Liebert XDO, near the top (see Figure 4.17 on the facing page).

Terminal block connections 37, 38 and 82 through 87 can be connected to a monitoring unit, such as Liebert SiteScan®. The remote shutdown, condensate detection alarm and fan failure alarms operate independently of each other.

- Contacts 37 and 38 are for remote shutdown.
- Contacts terminals 82, 83 and 84 are activated by the condensate detection alarm.
  - T82 is used for normally open contact closure requirements.
  - T83 is common.
  - T84 is used when normally closed contact closure is required.
- Contacts terminals 85, 86 and 87 are activated by the fan failure alarm.
  - T85 is for normally open contact closure requirements.
  - T86 is common.
  - T87 is used when normally closed contact closure is required. The condensate detection alarm and the fan failure alarm operate independently of each other.
- P66 and P67 are CAN bus ports.

Figure 4.17 Low-voltage wiring—Liebert XDO smart modules

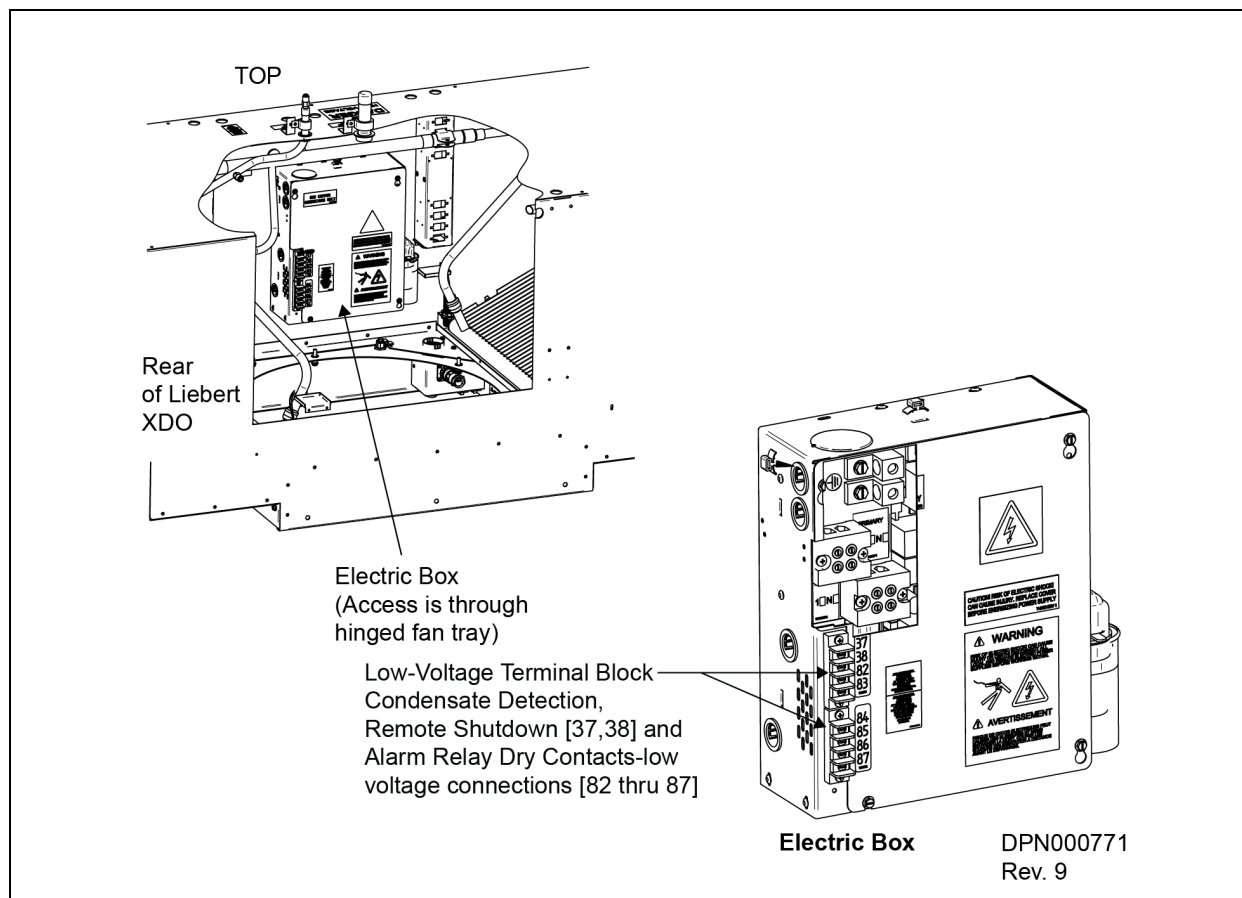

#### 4.12 Liebert XDR Standard Features

- **Micro-channel Heat Exchanger**—The Liebert XDR module includes two all-aluminum microchannel heat exchanger
- **Door Safety Catch**—Liebert XDR modules have a door safety catch to prevent the door from opening beyond 110°. When the door is fully open, the safety catch will hold the door in place. To release the door, push up on the door catch and close the door.
- **Removable Installation Handles**—The Liebert XDR will have four installation handles factory-installed to ease with installation and to be removed in the field after installation onto the rack to allow side-by-side placement of the racks.
- **Rack-Mount Kit**—The rack mount kits are constructed of 14-gauge steel to support the Liebert XDR on the rear of the equipment cabinet and painted black to match the module. The rack mount kit must be field-installed. Rack-mount kits are available for Knurr Miracel, APC AR3100, Dell PowerEdge 4210 and HP 10642. Contact the factory by calling 1-800-LIEBERT for kits to permit mounting on other rack types.

#### 4.13 Optional Features—Liebert XDR

- **Refrigerant Pre-Charge**—The Liebert XDR can be precharged with refrigerant. The module will have the one-shot fittings and will be pressurized. The one-shot Liebert XD Flex Piping will also be pre-charged with refrigerant.

- **Field-Installed Flexible Piping**—Field-installed flexible piping kits for use with prefabricated piping assemblies are available in lengths of 4, 6, 8 and 10 feet (1.2, 1.8, 2.4 and 3 meters). Connection style to the module end may be straight or 90 degrees with one-shot or removable connections.

Flex pipes with one-shot connections will have pressurized R134a. Flex pipes with removable connections will have a low-pressure nitrogen charge. Connection to the prefabricated piping assembly is with a threaded coupler. For information on acquiring the correct kit for your installation, refer to DPN000781, available from Liebert by calling 1-800-LIEBERT and from your local Vertiv representative.

#### 4.14 Liebert XDR Installation Considerations

Panels must be installed on the top and bottom of the rack to ensure that the air flows across the Liebert XDR's coils. If the panels are not installed, heated air will bypass the coils, drastically reducing the performance of the Liebert XDR.

**Table 4.1 Cooling capacity, 1500-3000 cfm air flow**

Degrees F				Degrees C			
Air flow (cfm)	EAT (°F)	Capacity (kW)	LAT (°F)	Air flow (cfm)	EAT (°C)	Capacity (kW)	LAT (°C)
1500	86.0	10.3	63.6	1500	30	10.3	17.5
1500	95.0	13.4	65.9	1500	35	13.4	18.9
1500	104.0	16.4	68.4	1500	40	16.4	20.2
1500	122.0	22.5	73.1	1500	50	22.5	22.9
1600	87.8	10.5	66.4	1600	31	10.5	19.1
1600	95.0	13.1	68.4	1600	35	13.1	20.2
1600	104.0	16.2	70.9	1600	40	16.2	21.6
1600	118.4	21.3	75.0	1600	48	21.3	23.9
1800	86.0	10.7	66.7	1800	30	10.7	19.3
1800	95.0	14.1	69.4	1800	35	14.1	20.8
1800	104.0	17.5	72.3	1800	40	17.5	22.4
1800	114.8	21.6	75.7	1800	46	21.6	24.3
2000	84.2	10.6	66.9	2000	29	10.6	19.4
2000	95.0	15.0	70.5	2000	35	15.0	21.4
2000	104.0	18.6	73.6	2000	40	18.6	23.1
2000	111.2	21.5	76.1	2000	44	21.5	24.5
2000	82.4	10.9	64.6	2000	28	10.9	18.1
2000	95.0	16.0	68.9	2000	35	16.0	20.5
2000	104.0	19.6	72.0	2000	40	19.6	22.2
2000	113.0	23.3	75.1	2000	45	23.3	23.9
2200	82.4	10.4	66.9	2200	28	10.4	19.4
2200	95.0	15.8	71.6	2200	35	15.8	22.0
2200	104.0	19.6	75.0	2200	40	19.6	23.9



**Table 4.1 Cooling capacity, 1500-3000 cfm air flow (continued)**

Degrees F				Degrees C			
Air flow (cfm)	EAT (°F)	Capacity (kW)	LAT (°F)	Air flow (cfm)	EAT (°C)	Capacity (kW)	LAT (°C)
2200	109.4	21.9	77.0	2200	43	21.9	25.0
2400	80.6	10.1	66.9	2400	27	10.1	19.4
2400	95.0	16.5	72.5	2400	35	16.5	22.5
2400	104.0	20.5	76.1	2400	40	20.5	24.5
2400	107.6	22.1	77.5	2400	42	22.1	25.3
2500	78.8	10.6	65.0	2500	26	10.6	18.3
2500	95.0	18.0	71.6	2500	35	18.0	22.0
2500	104.0	22.1	75.2	2500	40	22.1	24.0
2500	107.6	23.7	76.7	2500	42	23.7	24.8
3000	77.0	10.6	65.5	3000	25	10.6	18.6
3000	86.0	15.0	69.7	3000	30	15.0	20.9
3000	95.0	19.5	73.9	3000	35	19.5	23.3
3000	102.2	23.0	77.2	3000	39	23.0	25.1
55°F Refrigerant, 51°F dew point				12.8°C Refrigerant, 10.6°C dew point			

Figure 4.18 Liebert XDR dimensions with hard-piped connections

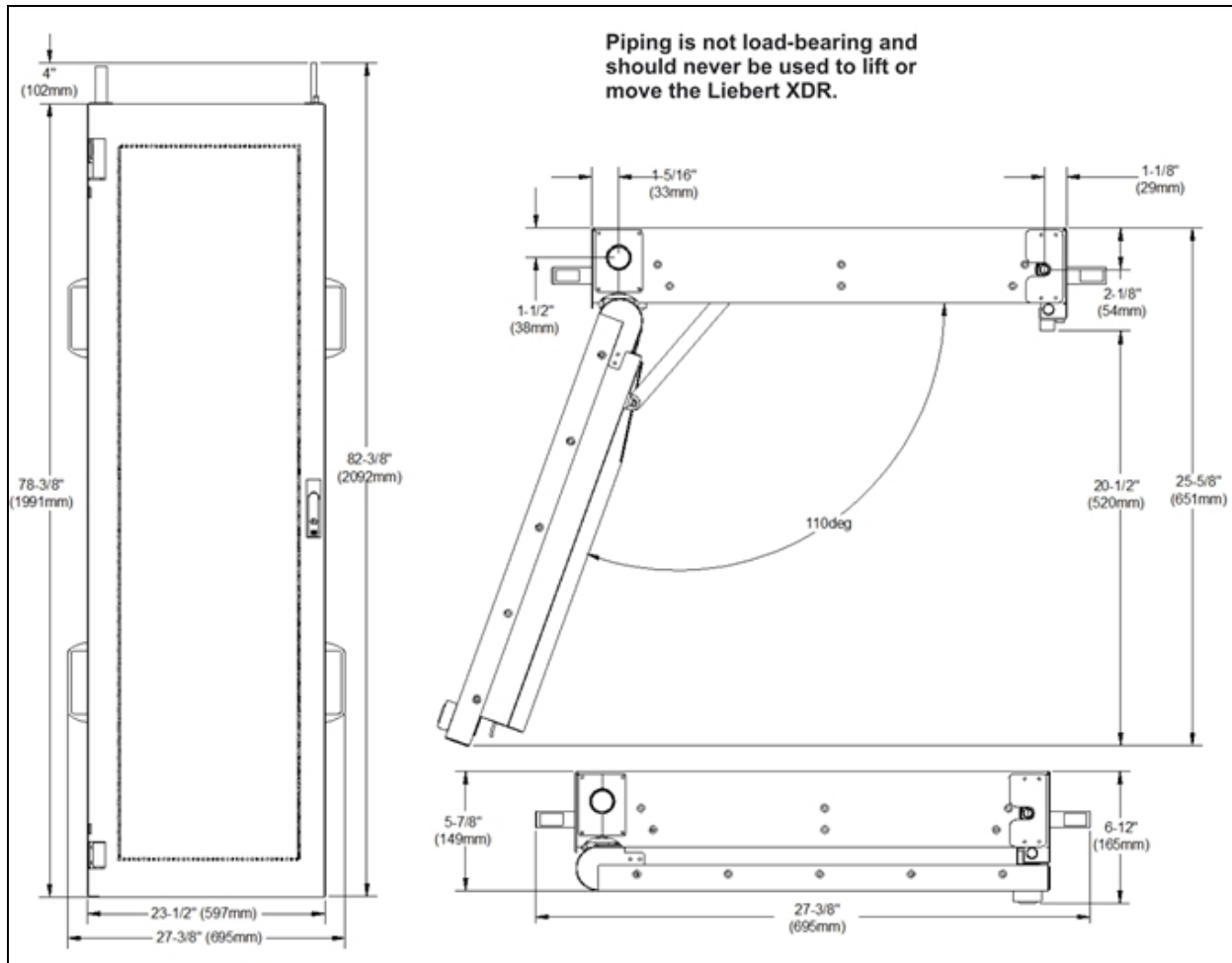

**NOTE:** The handles are for moving the Liebert XDR and can be removed after the module is secured to the rack.

Figure 4.19 Liebert XDR dimensions with one-shot connections (precharged)

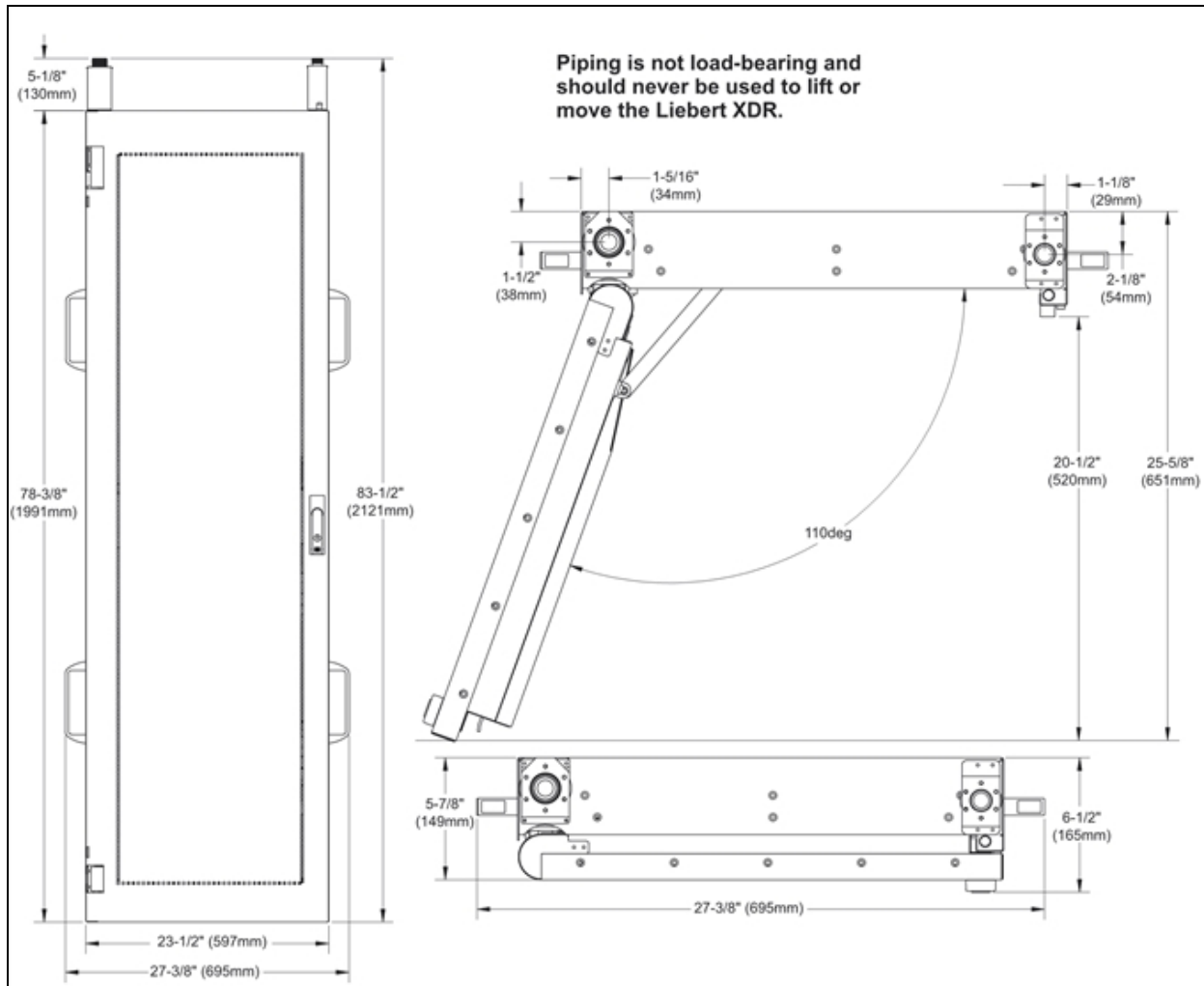

**NOTE:** The handles are for moving the Liebert XDR and can be removed after the module is secured to the rack.

Figure 4.20 Liebert XDR dimensions with removable connections

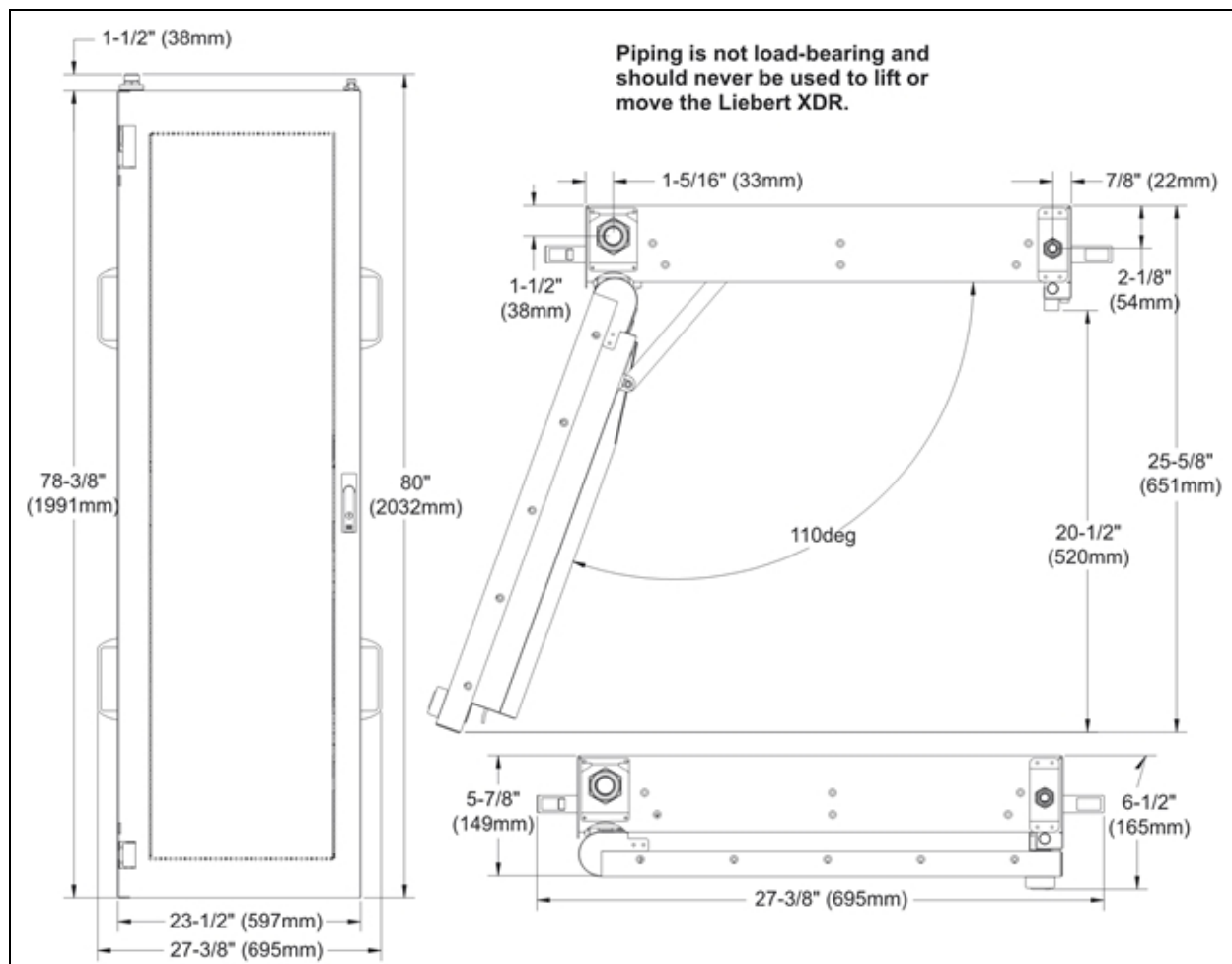

**NOTE:** The handles are for moving the Liebert XDR and can be removed after the module is secured to the rack.

#### 4.15 Liebert XDV Standard Features

- **Micro Channel Heat Exchanger**—The Liebert XDV module includes one all-aluminum micro channel heat exchanger.
- **Dual IEC Power Cords and Power Inlets**—The Liebert 115V, 60Hz Liebert XDV module is supplied with two detachable, 10 ft (3m) power cords that attach to two IEC power inlets in the rear of the module. Each power cord has a NEMA 5-15P (IEC 320-C14) plug at the opposite end. The Liebert 230V, 60/50 Hz Liebert XDV module is supplied with two non-detachable 10 ft (3m) power cords. This feature allows the module to be powered by two separate power sources.
- **Dual Air Inlets**—The Liebert XDV module can be configured to allow air to enter from the rear grille or the bottom of the module.
- **Dual Fans**—Airflow is provided by two fans on the front of the module.
- **Dual Switches**—Controls on the front of the module permit the use of one fan or both fans.

- **Liebert Foundation Mounting**—Two 1/4-20 cage nuts on the underside of module allow direct attachment to any Liebert Foundation cabinet; bolts provided with Liebert XDV module.
- **Mounting Clips for Non-Liebert Cabinets**—The Liebert XDV module is supplied with mounting clips that allow attachment to a non-Liebert cabinet (some drilling may be required).

#### 4.16 Optional Features—Liebert XDV

- **Refrigerant Pre-Charge**—The Liebert XDV can be precharged with refrigerant. The module will have the one-shot fittings and will be pressurized. The one-shot Liebert XD Flex Piping will also be precharged with refrigerant.
- **External Mounting Brackets**—The Liebert XDV can be suspended from the overhead building structure. The external mounting brackets are ship-loose items.
- **Field-Installed Flexible Piping** (for use with prefabricated piping assemblies)—Field-installed flexible piping kits are available in lengths of 4, 6, 8 and 10 feet (1.2, 1.8, 2.4 and 3 meters). Connection style to the module end may be straight or 90 degrees with one-shot or removable connections. Flex pipes with one-shot connections will have pressurized R134a. Flex pipes with removable connections will have a low pressure nitrogen charge. Connection to the prefabricated piping assembly is with a threaded coupler. For information on acquiring the correct kit for your installation, refer to DPN000781, available from Liebert by calling 1-800-LIEBERT and from your local Vertiv representative.
- **Smart Module**—Liebert XDV smart modules allow remote shutdown, fan failure alarms and automatically switching the second fan On and Off. This saves energy by permitting the module to run with one fan and switching on a second fan when the temperature requires both fans for cooling. Liebert XD smart modules are able to provide alarm conditions such as fan failure or condensate detection at the Liebert XDP display via CANbus communication. For electrical connection details, refer to the Liebert XDV user manual, SL-16626, available on the Vertiv web site: [www.VertivCo.com](http://www.VertivCo.com)

Figure 4.21 Liebert XDV dimensions

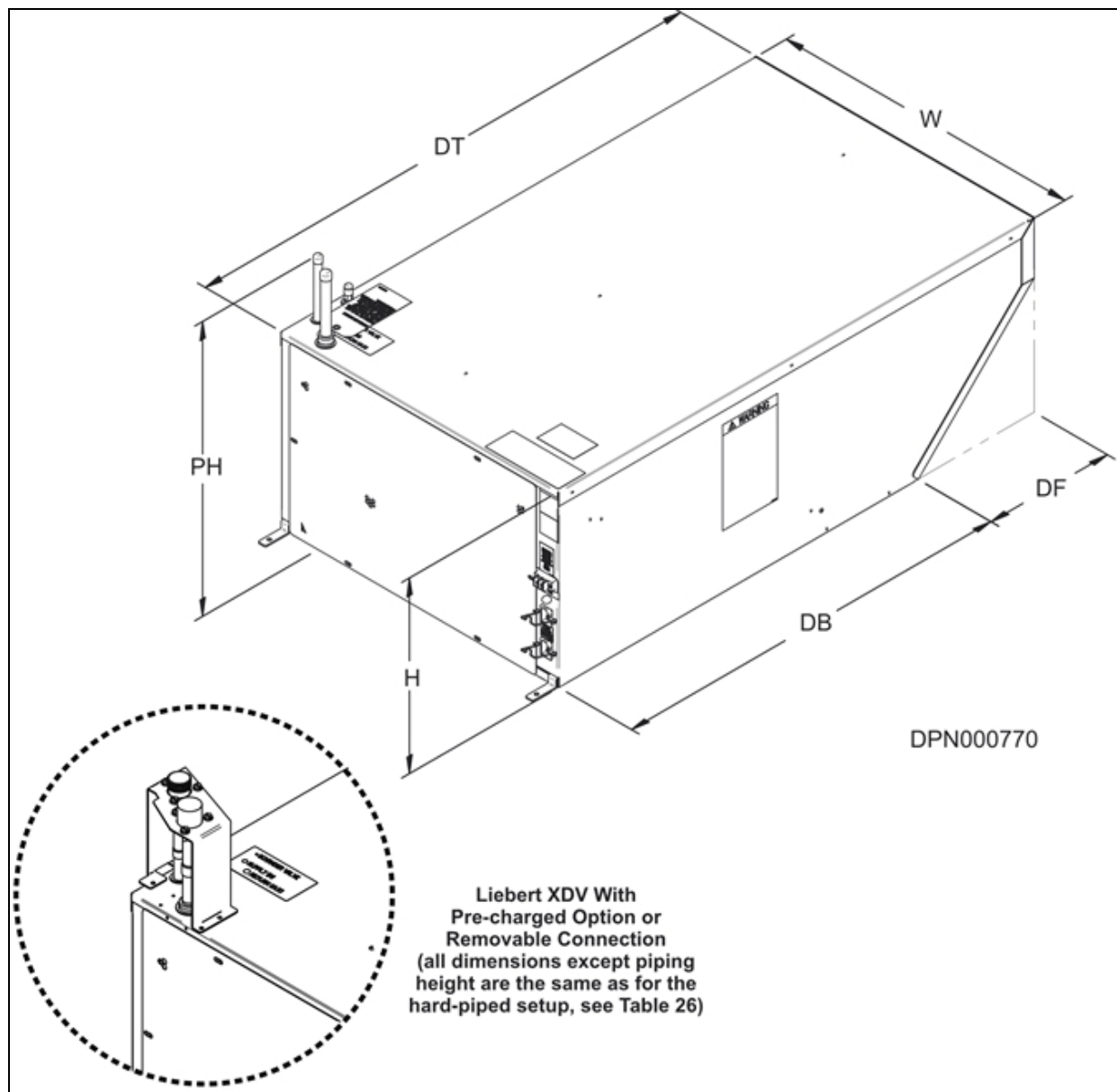

**Table 4.2 Dimensional data**

Illustration Key	Dimension	Measurement, in. (mm)
DT	Depth Top	
DB	Depth Bottom	
W	Width	
H	Height	
PH	Piping Height, hard-piped	18-5/8 (473)
	Piping Height, one-shot option or removable connection	19-5/8 (498)
	Depth Front	9-7/8 (250)

**Figure 4.22 Liebert XDV dimensions with one-shot connection**

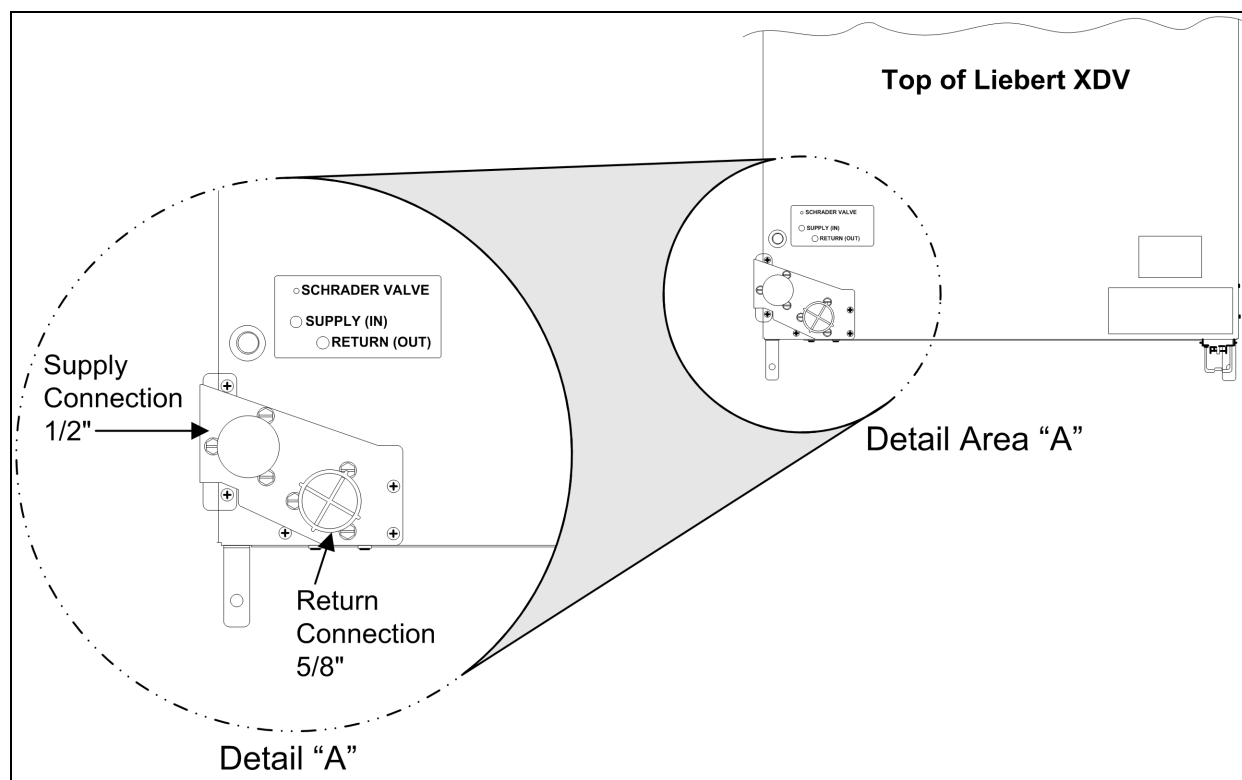

Figure 4.23 Suspending single Liebert XDV from Unistruts

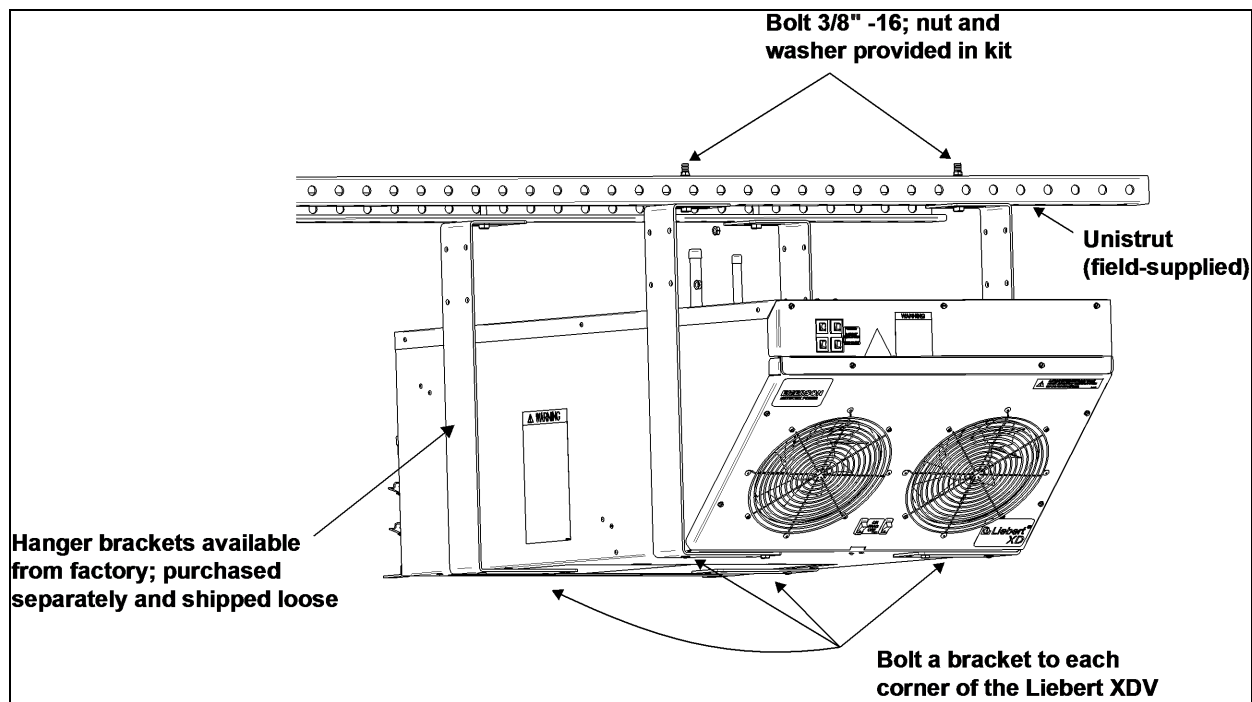



Figure 4.24 Suspending single Liebert XDV from the roof structure

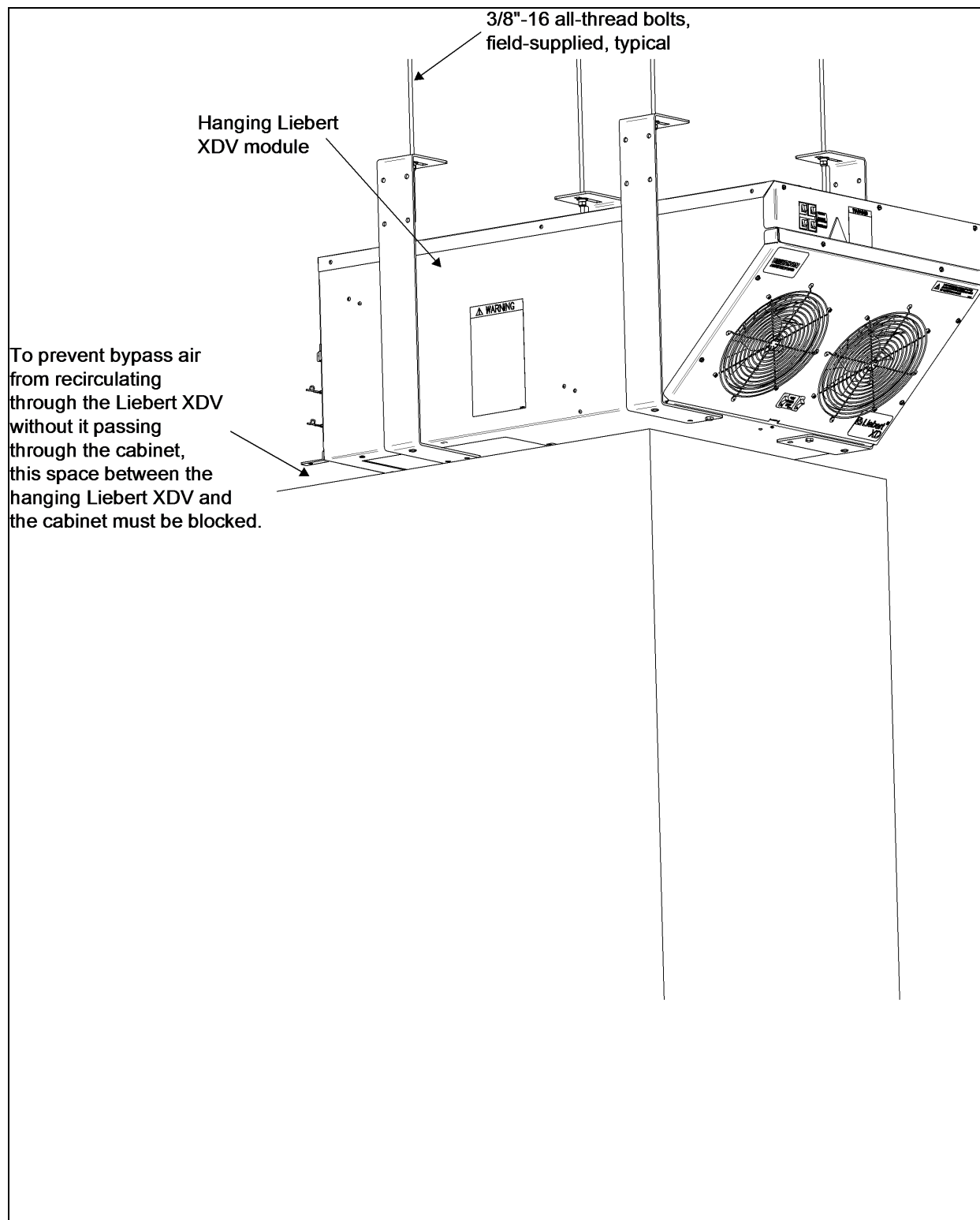
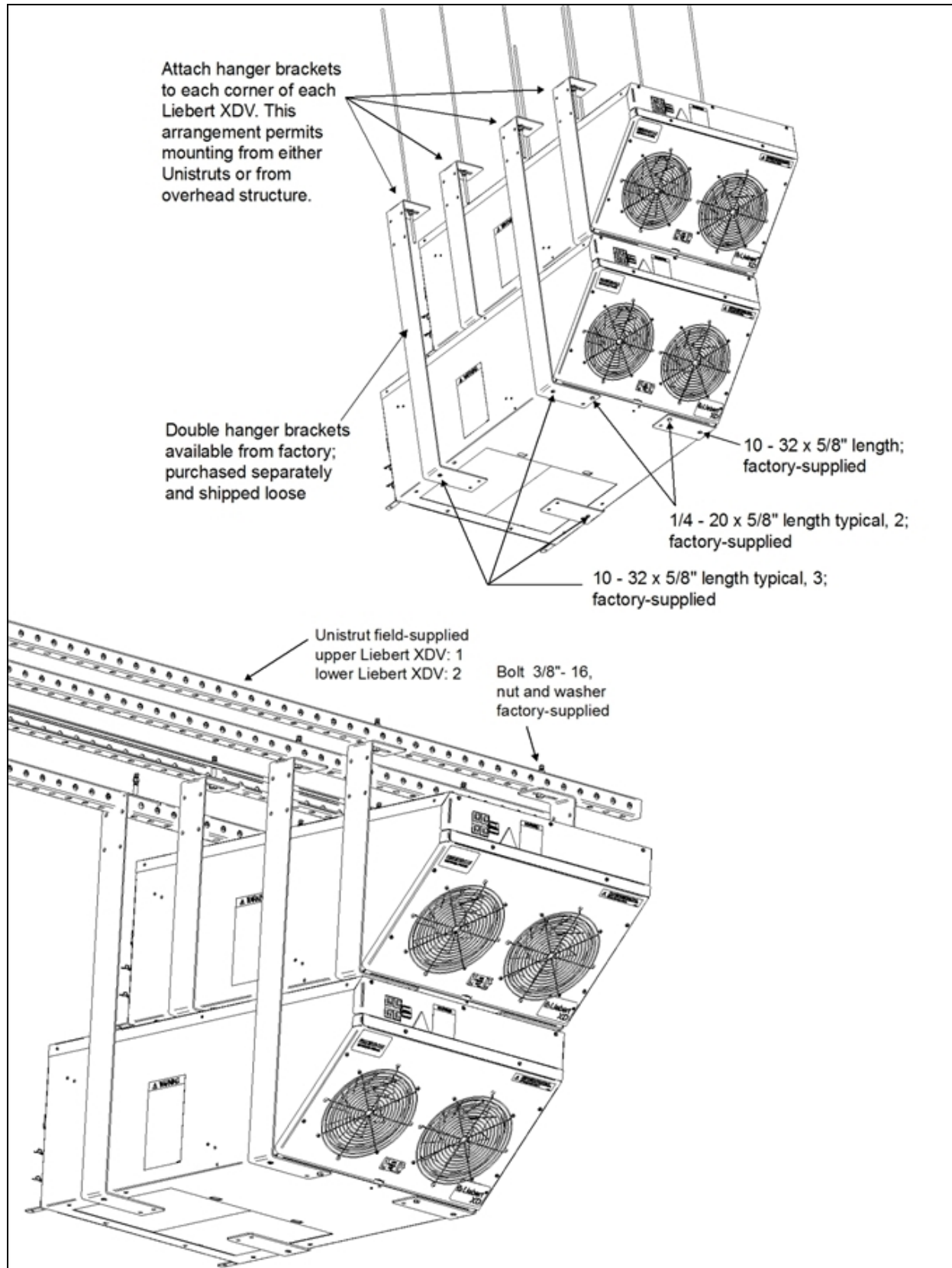

Figure 4.25 Alternate mounting methods—mounting multiple Liebert XDV modules



## 4.17 High-Voltage Cabling for Liebert XDV

The Liebert XDV ships with two IEC input power cords. IEC power cords connect to receptacles on the Liebert XDV and to power sources. See Figure 4.26 on the next page and Figure 4.27 on page 95 for power connection locations on basic modules; see Figure 4.28 on page 96 and Figure 4.29 on page 97 for power connection locations on smart modules.

Figure 4.26 Electrical connections for CSA-approved Liebert XDV basic modules

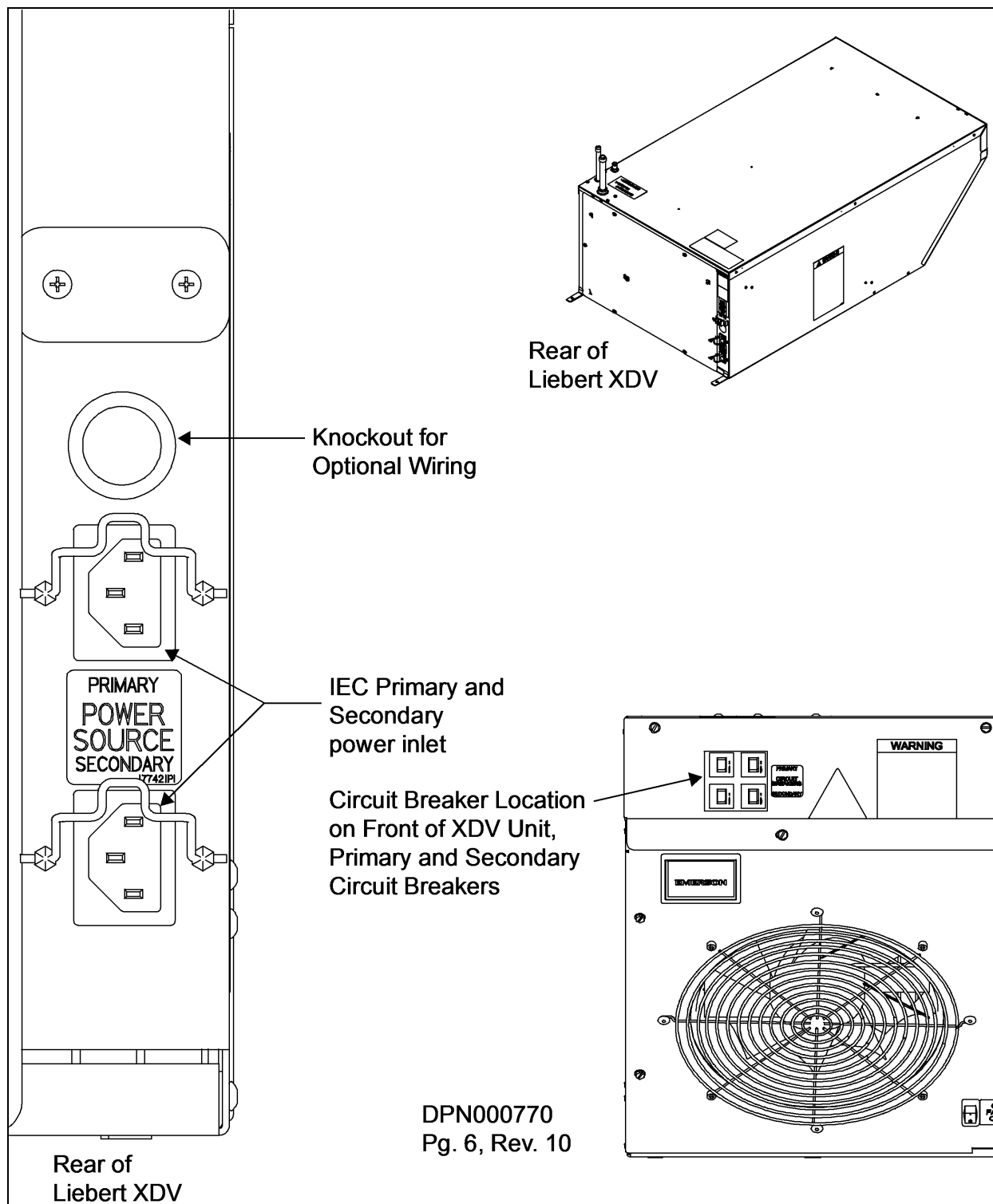

Figure 4.27 Electrical connections for CE-approved Liebert XDV basic modules

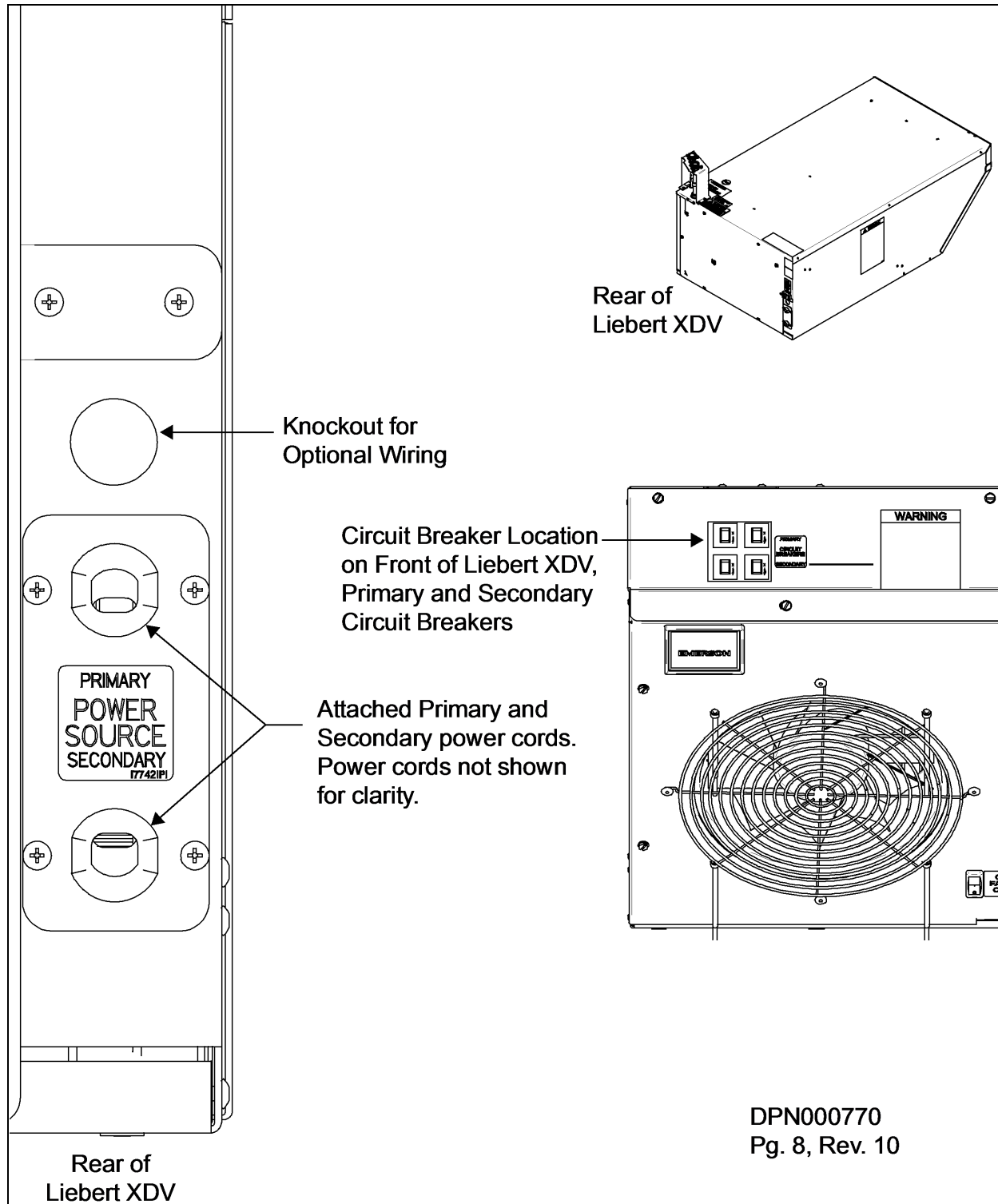

Figure 4.28 Electrical connections for CSA-approved Liebert XDV smart modules

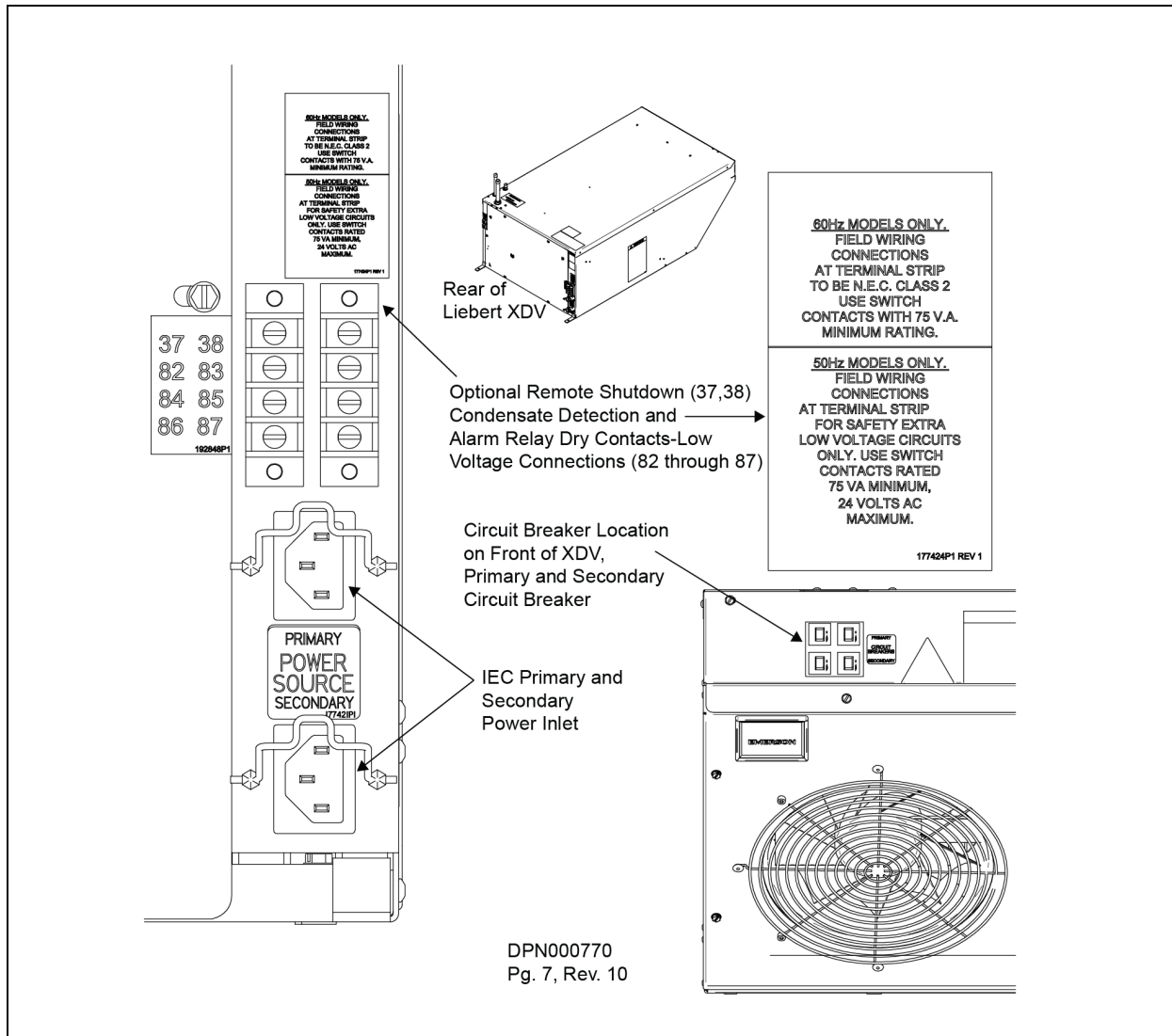
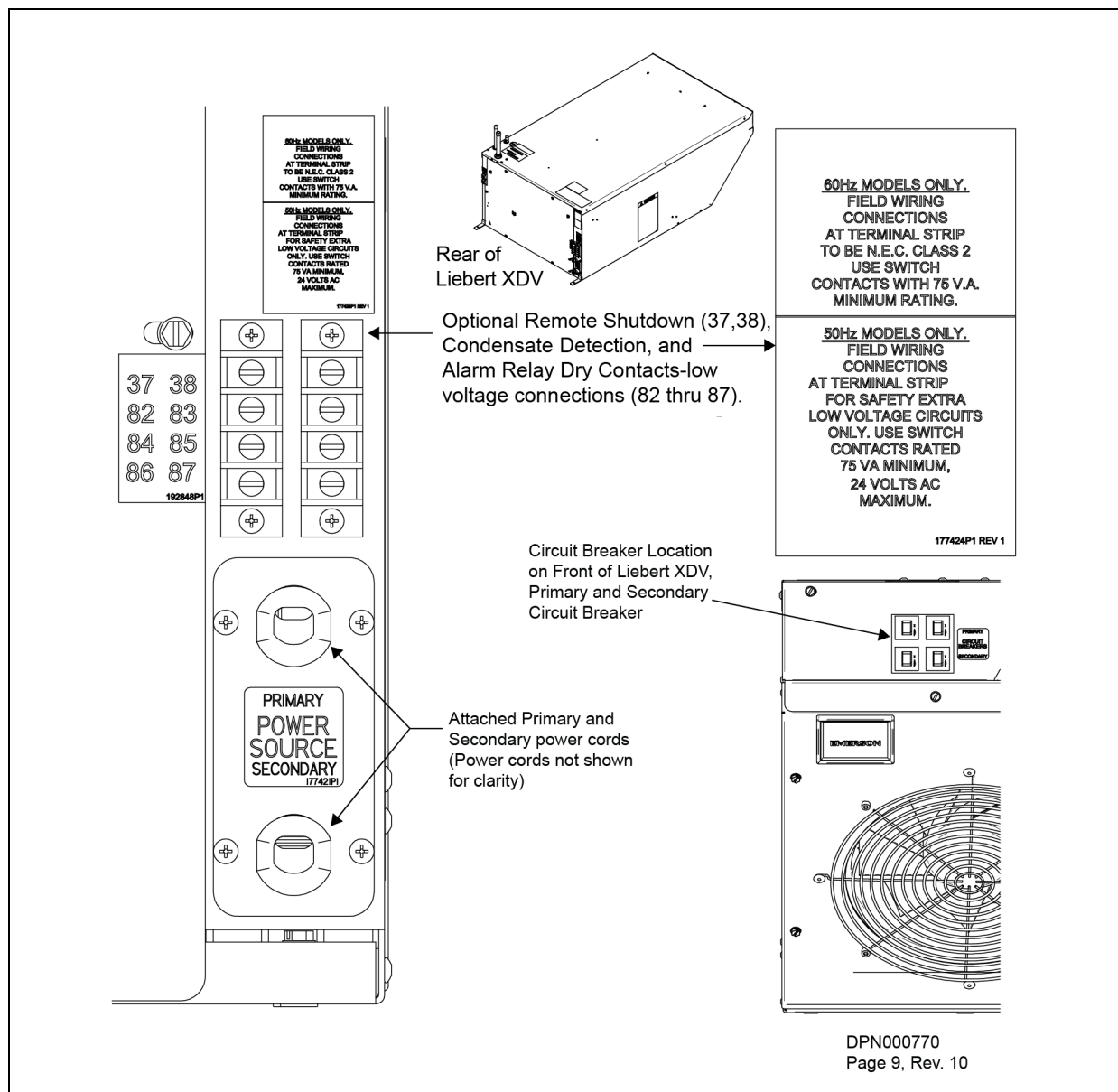

Figure 4.29 Electrical connections for CE-approved Liebert XDV smart modules



#### 4.18 Low-Voltage Wiring—Liebert XDV Smart Modules

The low-voltage connections for Liebert XDV smart modules are on the rear right side of the modules. The power connections are shown in Figure 4.30 on the next page and the dry contacts can be connected to a monitoring module, such as Liebert SiteScan®. Make low-voltage connections on these modules according to site-specific drawings. The module must be installed in accordance with national and local wiring regulations.

Terminal block connections 37, 38 and 82 through 87 can be connected to a monitoring unit, such as Liebert SiteScan. The remote shutdown, condensate detection alarm and fan failure alarms operate independently of each other.

- Contacts 37 and 38 are for remote shutdown.

- Contacts terminals 82, 83 and 84 are activated by the condensate detection alarm.
  - T82 is used for normally open contact closure requirements.
  - T83 is common.
  - T84 is used when normally closed contact closure is required.
- Contacts terminals 85, 86 and 87 are activated by the fan failure alarm.
  - T85 is for normally open contact closure requirements.
  - T86 is common.
  - T87 is used when normally closed contact closure is required. The condensate detection alarm and the fan failure alarm operate independently of each other.
- P66 and P67 are CAN bus ports.

**Figure 4.30 Low-voltage connections for Liebert XDV smart modules**

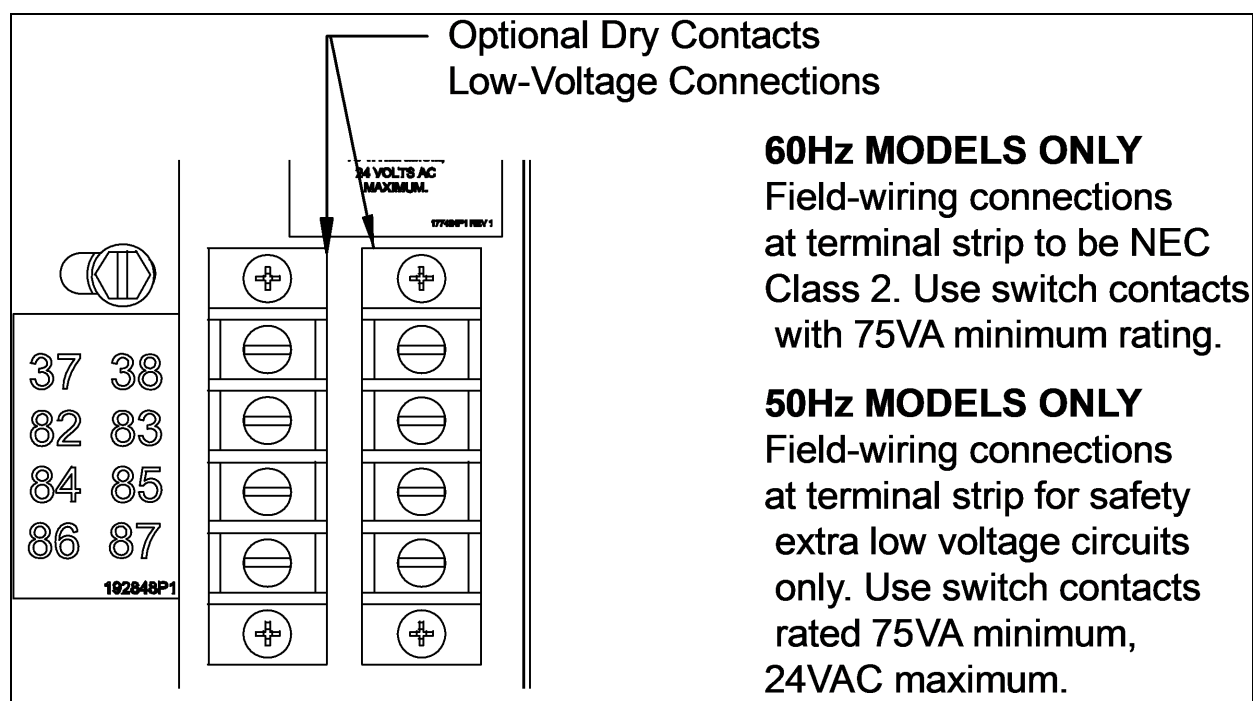



## 5 LIEBERT XDC AND LIEBERT XDP

### 5.1 Liebert XDC Standard Features

- **Compressors**—Scroll with a suction gas cooled motor, vibration isolators, thermal overloads, manual reset high-pressure switch and pump down low-pressure switch.
- **Refrigeration System**—Dual refrigeration circuits each including liquid line filter dryers, refrigerant sight glass with moisture indicator, electronic control valve, adjustable externally equalized expansion valves and liquid line solenoid valves.
- **Heat Exchanger**—Brazed plate design with interwoven circuiting constructed of stainless steel plates, copper brazed.
- **Pumps**—Centrifugal type, end suction, canned rotor design.
- **Liebert iCOM**—The Liebert iCOM offers the highest capabilities in unit control, communication and monitoring of Liebert Precision Cooling units. The Liebert iCOM is a factory-installed assembly. Operating conditions and status are indicated on the unit display, which is mounted either on the unit or on the wall, depending on application details (see the Liebert XDC user manual, SL-16674, available at [www.VertivCo.com](http://www.VertivCo.com). The control system also monitors unit operation and activates an alarm when any of the specified factory preset conditions are exceeded. The unit includes two temperature-humidity sensors to aid in effective cooling.
- **Liebert Lee-Temp™ Refrigerant Control Air-Cooled Condenser**—The Liebert Lee-Temp head pressure control system is designed to maintain proper operating head pressures in outdoor temperatures down to -30°F (-34.4°C). The condensers utilize head pressure control valves, extra refrigerant and insulated refrigerant receivers with heater pads. It works by flooding the condenser coil with liquid refrigerant to a level that balances the system condensing requirements with the condenser coil surface available to reject the system heat. During the summer, the system requires the entire condenser coil surface for heat rejection and most of the refrigerant is stored in a receiver. In the winter, the same amount of heat can be rejected by only a fraction of the coil surface. As head pressure begins to fall, the control valve restricts the flow of liquid refrigerant exiting from the condenser. This extra liquid refrigerant reduces the effective condenser surface area available for heat transfer. The head pressure control valve also bypasses hot gas into the receiver to warm the liquid and maintain liquid pressure for proper operation of the expansion valve. Condenser fan controls are either fan cycling on ambient temperature or constant on.

#### 5.1.1 Liebert XDC Optional Features

- **Water / Glycol Condensers**—A water/glycol floor stand condenser option is available for heat rejection requirements. The water/glycol floor stand can be installed beneath the Liebert XDC or nearby.

Figure 5.1 Dimensional data

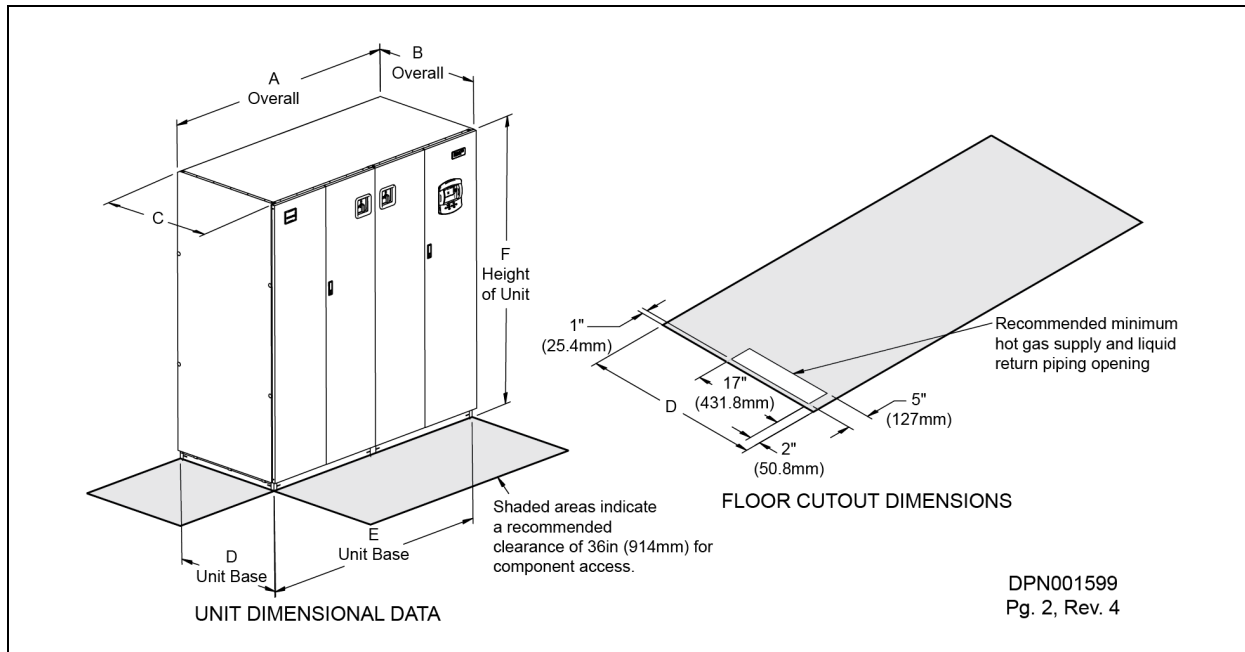

Table 5.1 Liebert XDC dimensions, weight

Air-Cooled Model	Dimensional Data, inches (mm)						Shipping Weight lb. (kg)	
	A	B *	C	D	E	F	Domestic	Export
50/60Hz								
XDC160	74 (1880)	34 (864)	33-1/8 (841)	33 (838)	72 (1829)	78 (1981)	1975 (896)	2109 (957)

\*Dimension does not include the bezel of the disconnect switch or iCOM display.

Figure 5.2 Piping locations

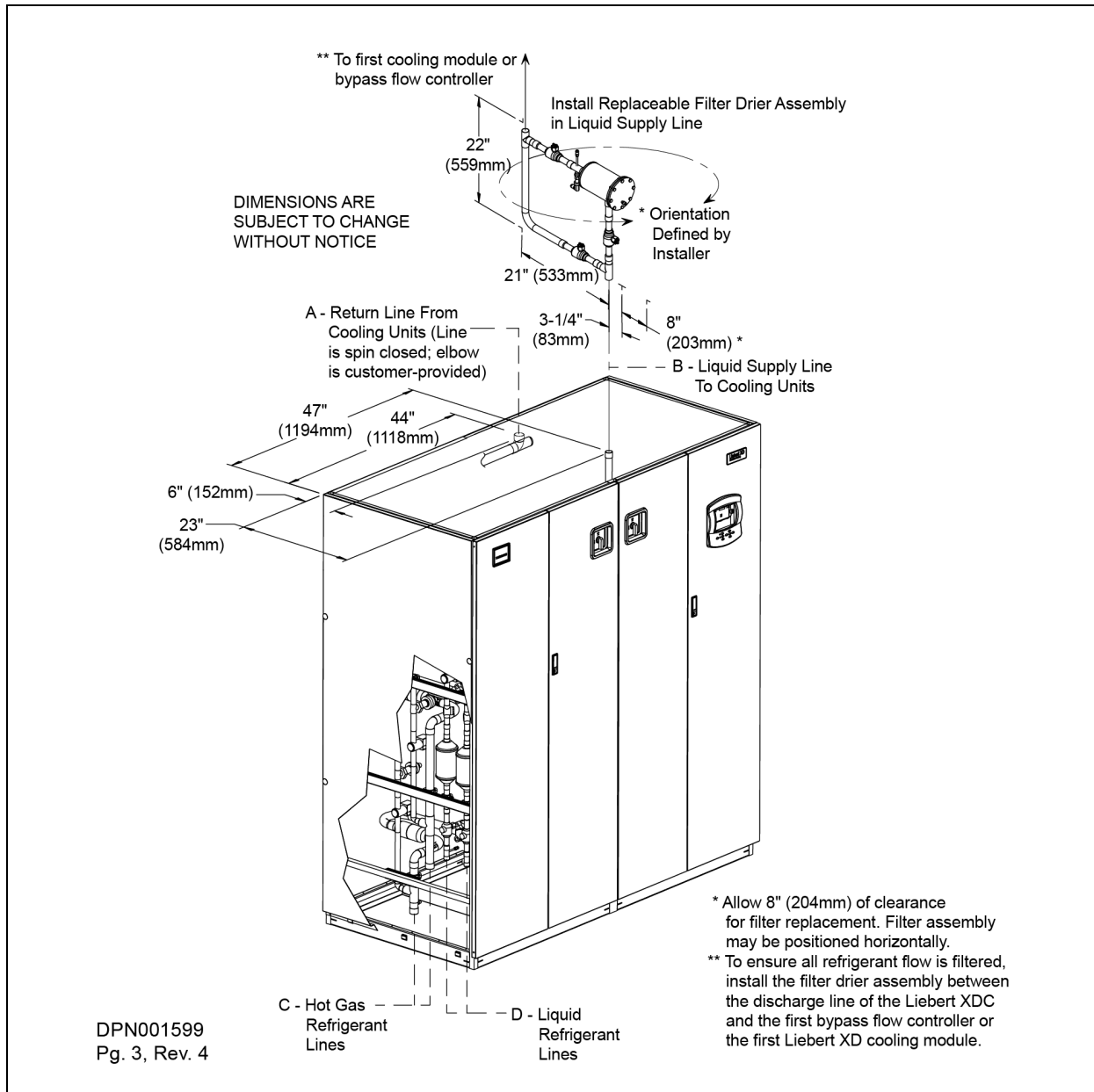

Table 5.2 Liebert XDC piping connection sizes

50/60Hz	Piping Outlet Connection Sizes, OD Cu, inches			
	A	B	C	D
XDC160	2-1/8	1-1/8	1-3/8	7/8

Source: DPN001599

Figure 5.3 Positioning a water/glycol Liebert XDC for placement on a floor stand

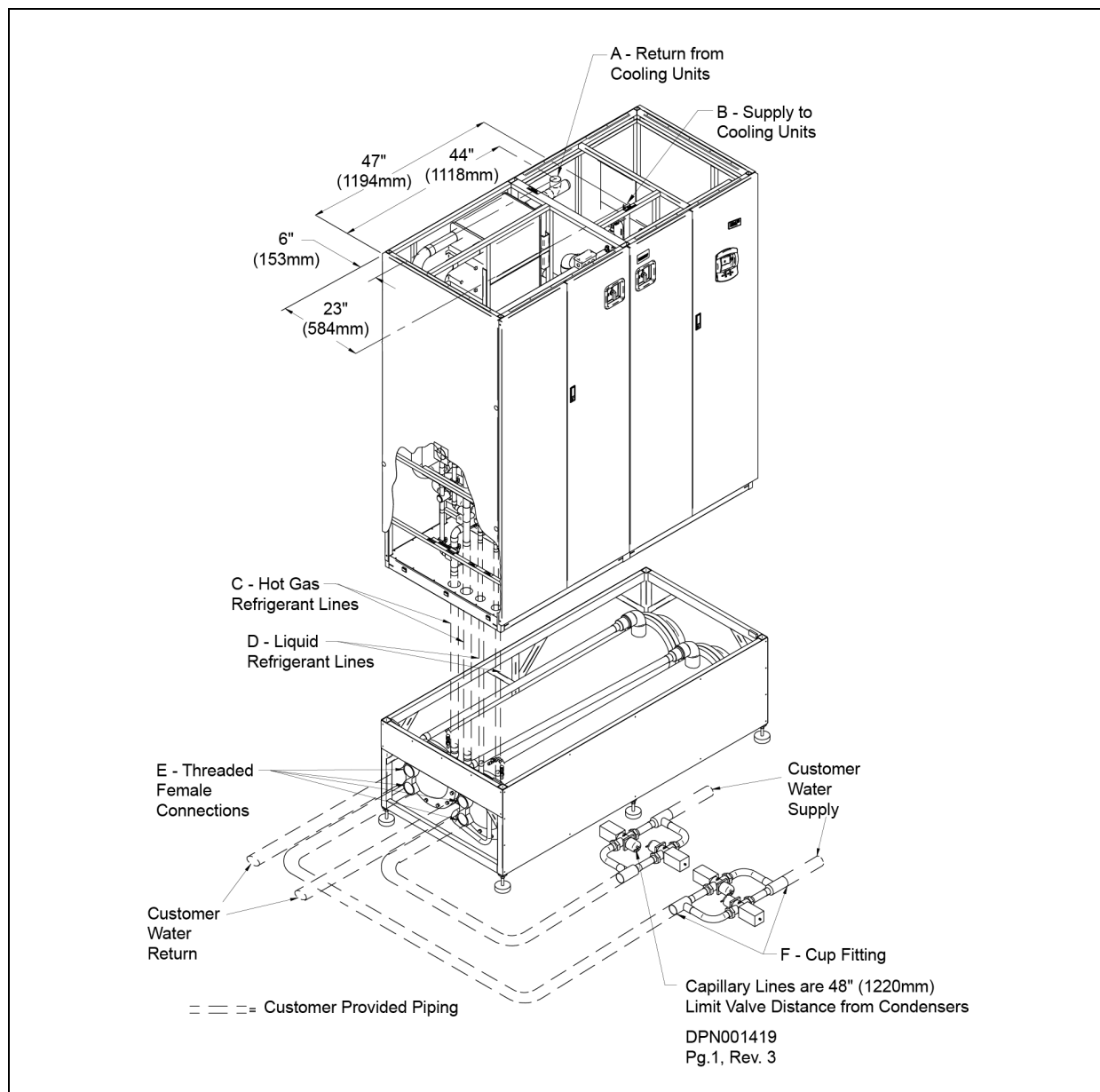

Table 5.3 Liebert XDC Water/Glycol Piping Connection Sizes

Model	Piping Outlet Connection Sizes, OD Cu, inches					
	A	B	C	D	E*	F**
XDC160	2-1/8	1-1/8	1-3/8	7/8	2-1/2	2-1/8 or 2-5/8
*Threaded Female Connection						
**2-1/8" for 1" WRV, 2-5/8" for 1-1/4" WRV						

Figure 5.4 Piping locations—floor stand and valve assembly

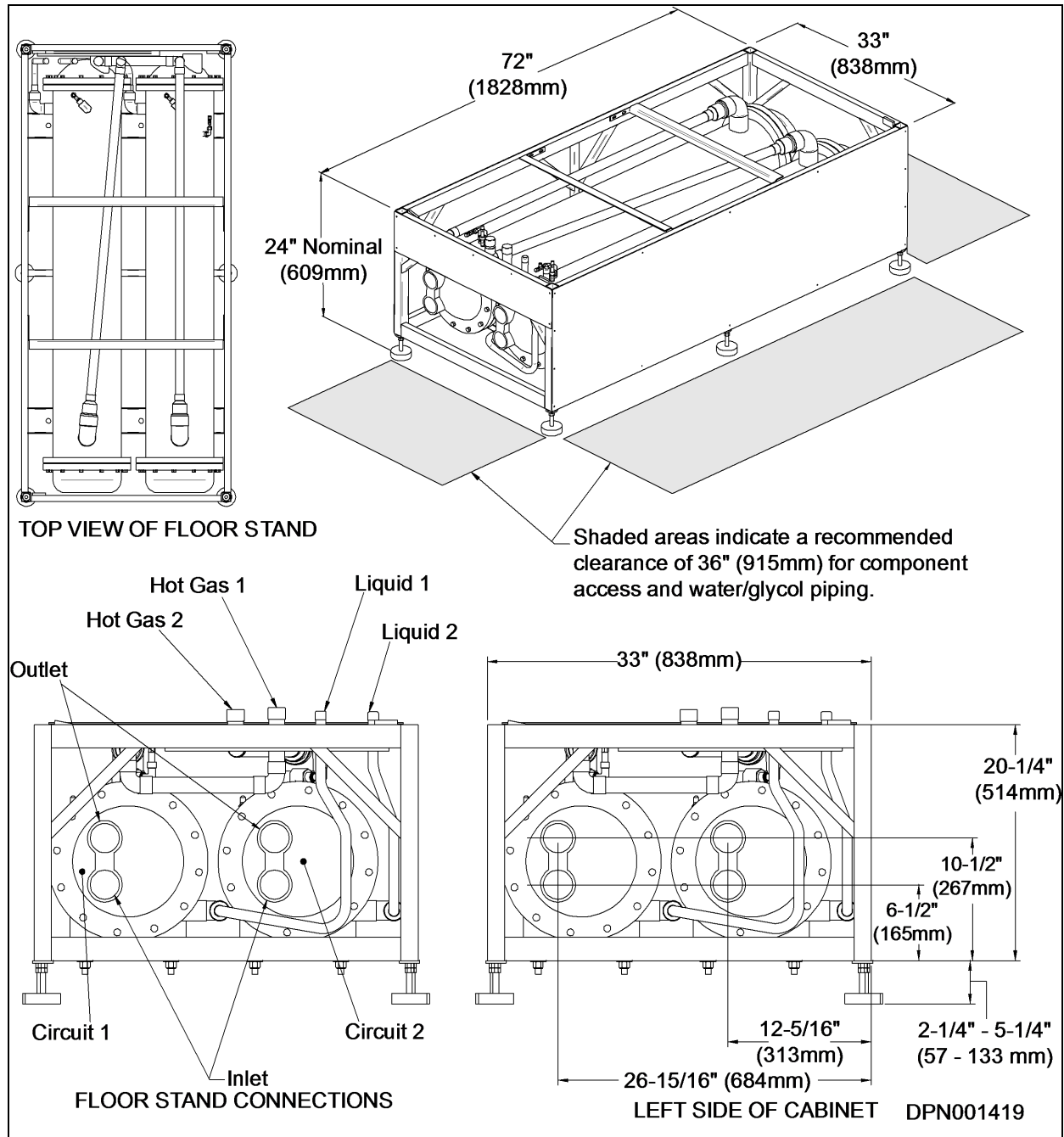

Figure 5.5 Front view of Liebert XDC and electrical enclosures

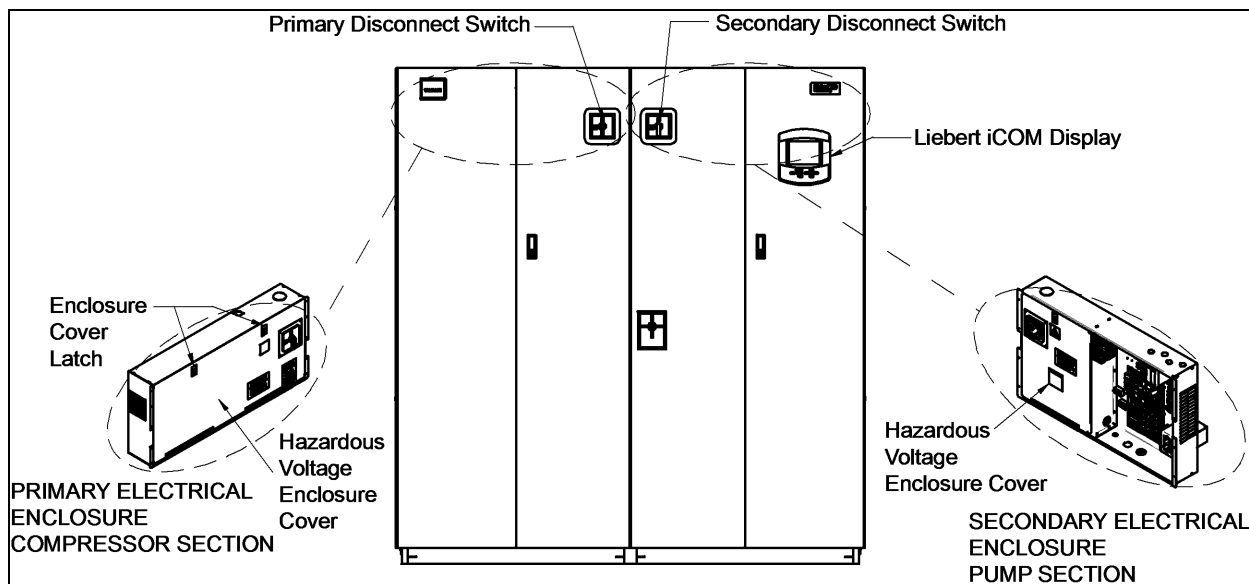

Figure 5.6 Liebert XDC electrical enclosure knockout locations for field wiring

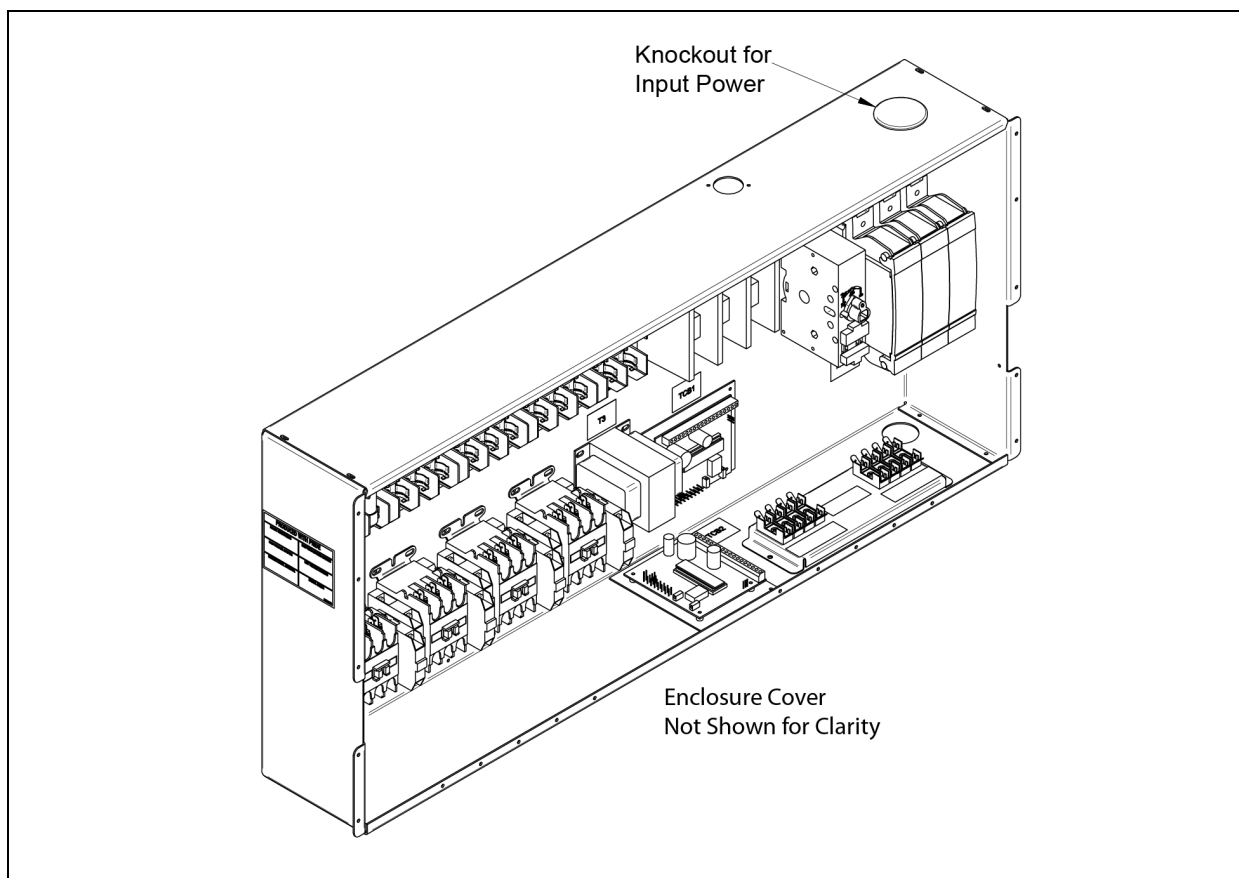

Figure 5.7 Liebert XDC high-voltage connections—primary disconnect switch, 60Hz models

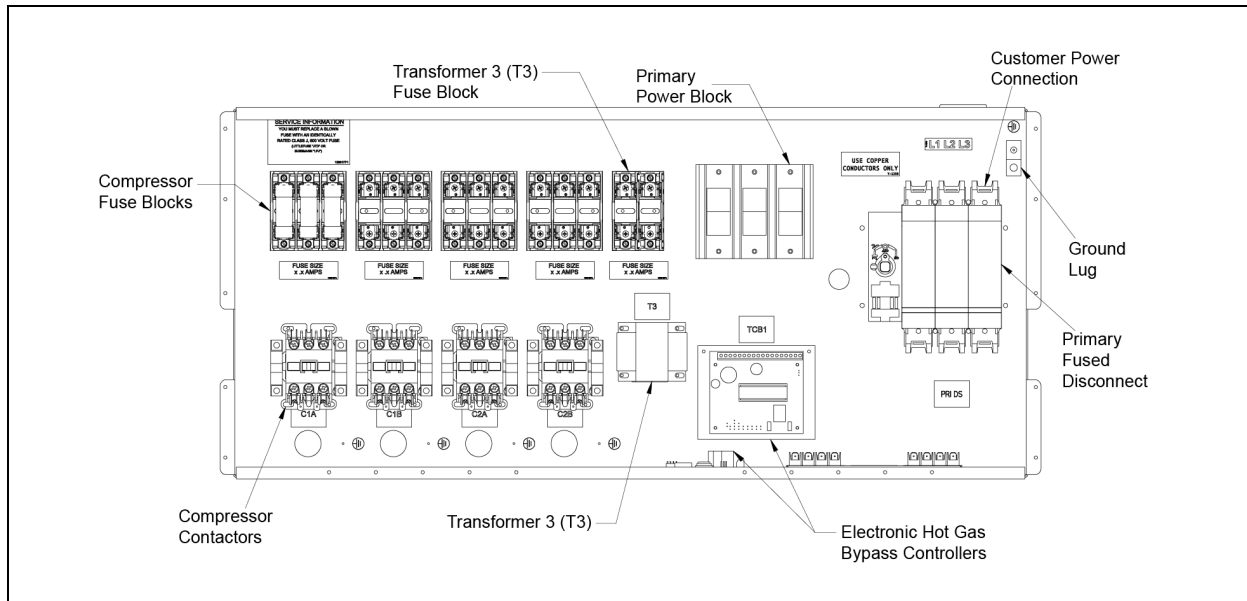

Figure 5.8 Liebert XDC high-voltage connections—primary disconnect switch, 50Hz models

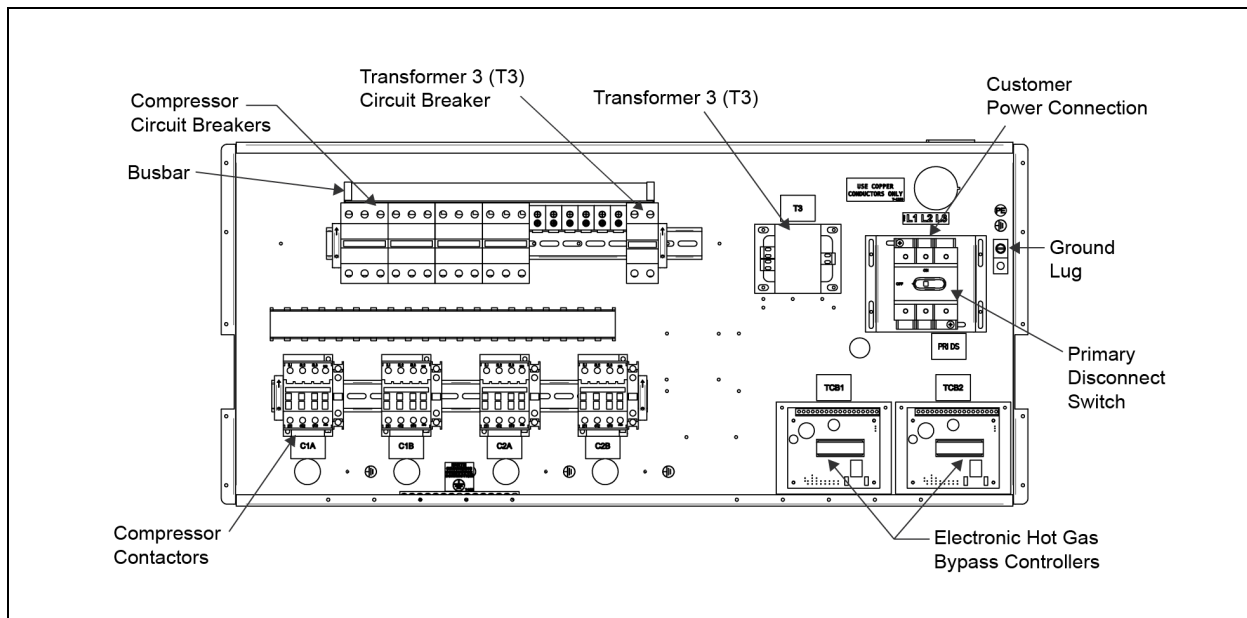

Figure 5.9 Liebert XDC high-voltage connections—secondary disconnect switch, 60Hz models

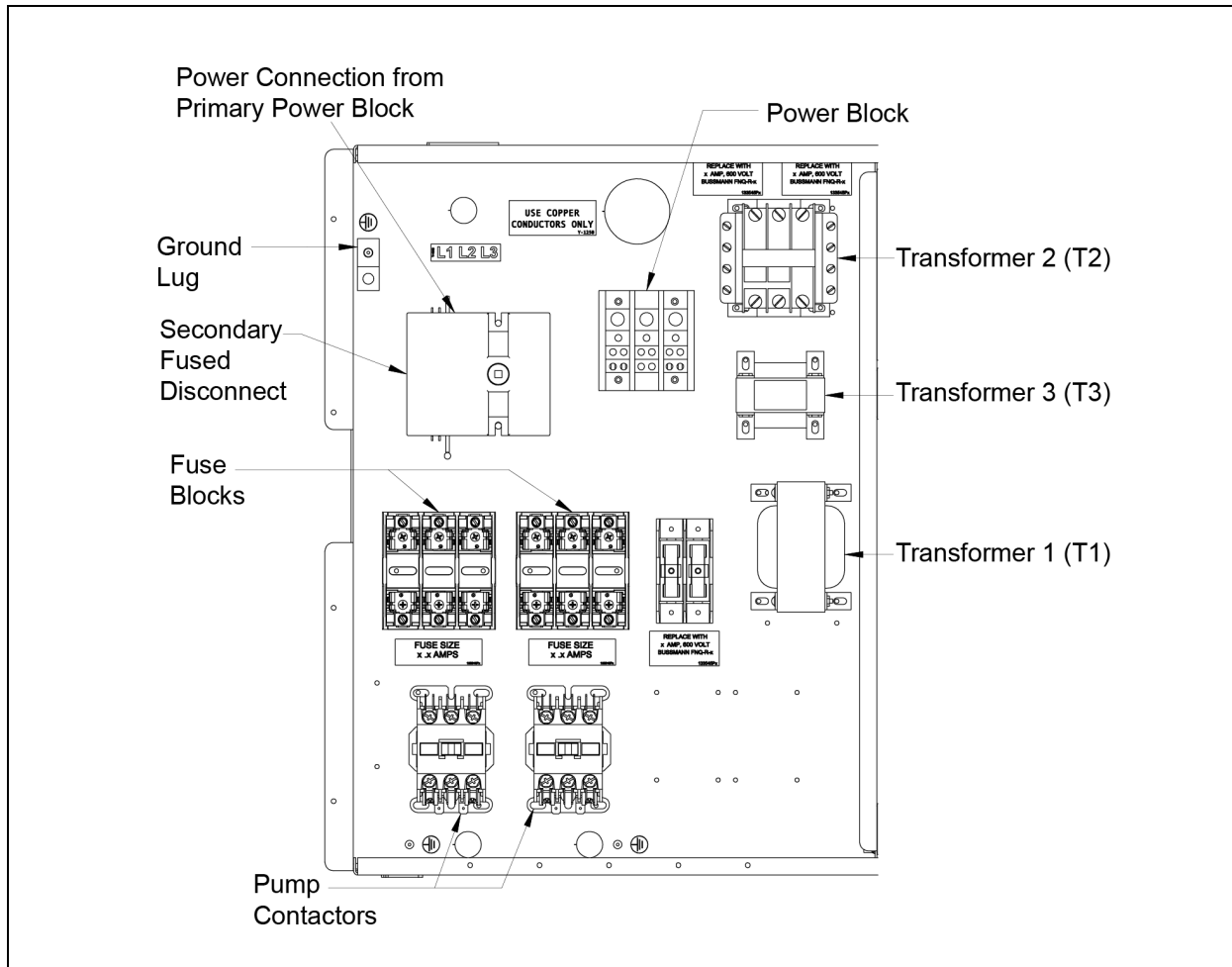



Figure 5.10 Liebert XDC high-voltage connections—secondary disconnect switch, 50Hz models

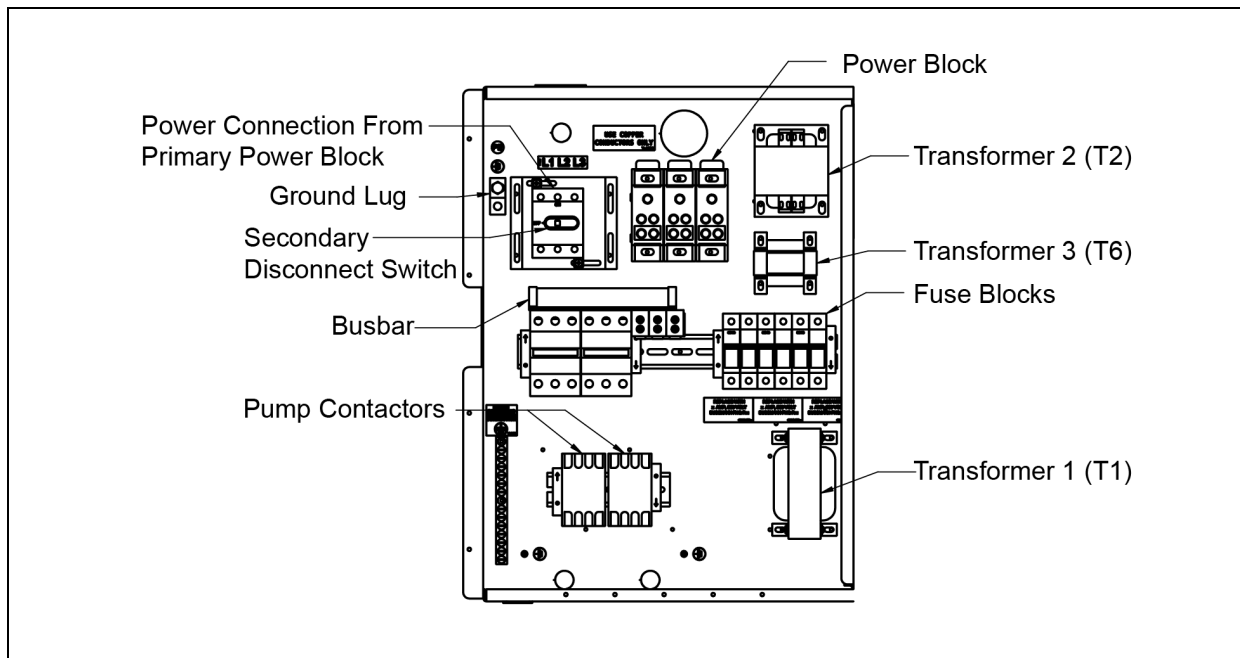

Figure 5.11 Liebert XDC heat rejection electrical connection points

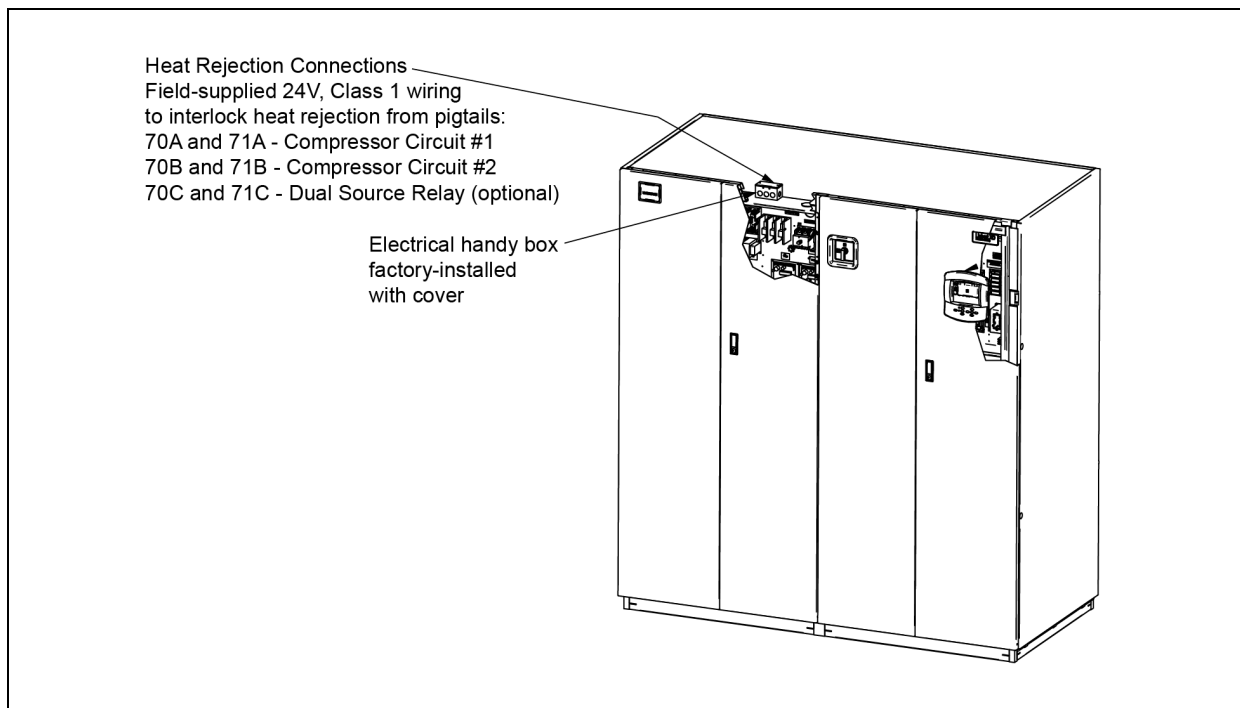

Figure 5.12 Liebert XDC electrical enclosure knockout locations for Extra Low-Voltage connections

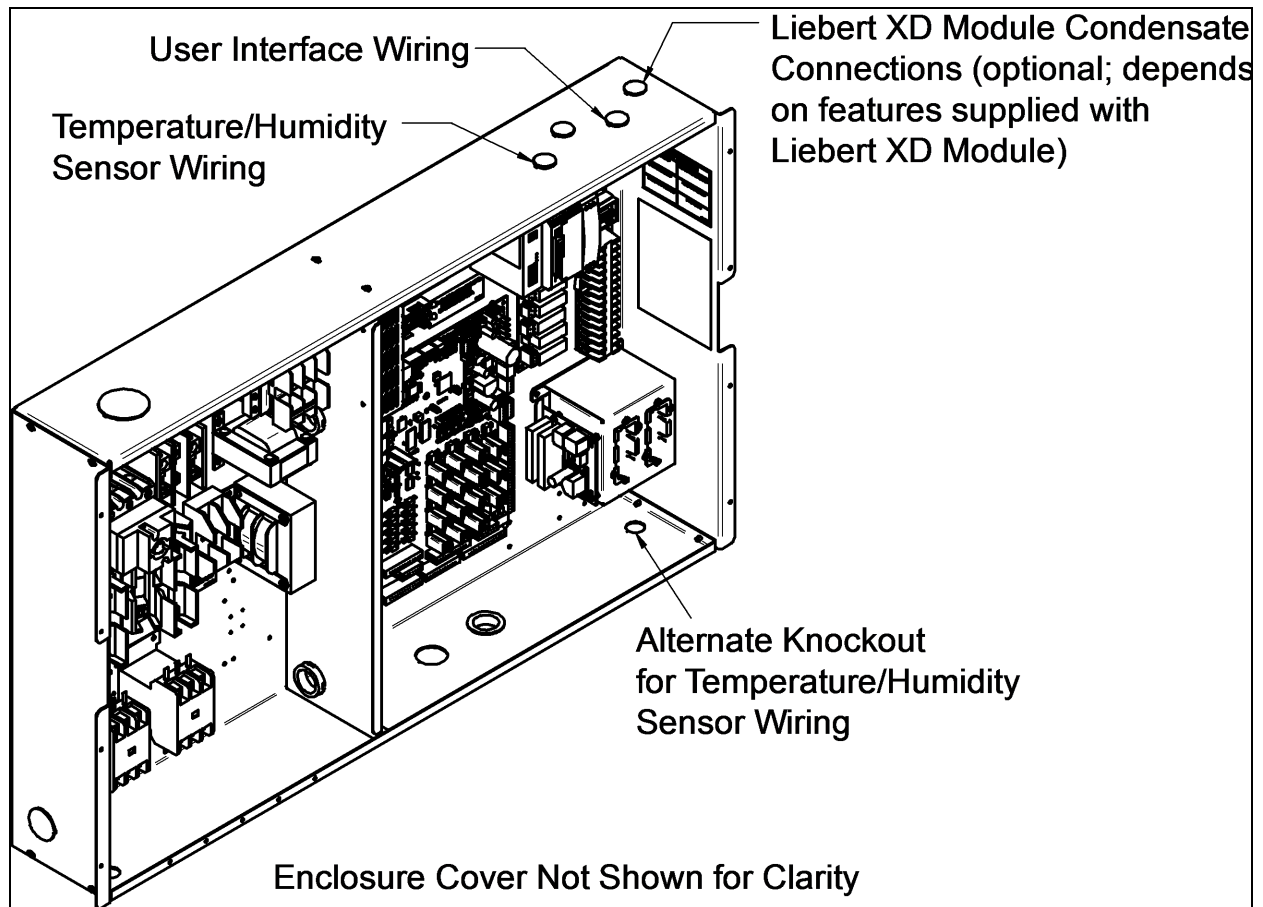
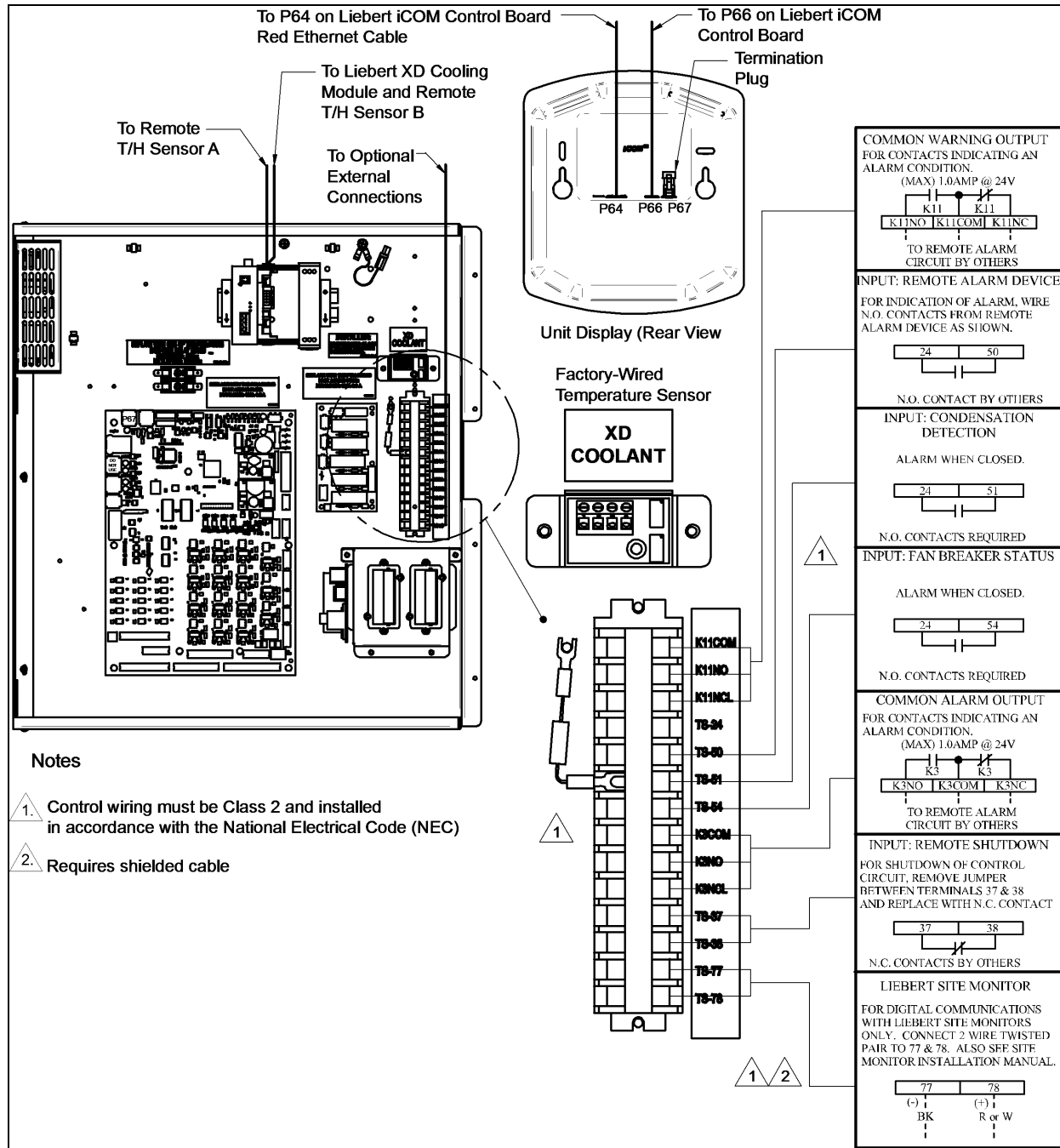

Figure 5.13 Liebert XDC Extra Low Voltage field connection points



## 5.2 Liebert XDP Standard Features

- Heat Exchanger—Brazed plate design with interwoven circuiting constructed of stainless steel plates, copper brazed.
- Pumps—Centrifugal type, end suction, internally cooled, canned rotor design.

- Cabinet and Frame**—Custom powder painted steel panels. A hinged control access panel opens to a second front panel, which is a protected enclosure for all high-voltage components. Frame is constructed of 14 gauge heliarc welded tubular steel and painted using an auto-deposition coating system.
- Liebert iCOM**—The Liebert iCOM offers the highest capabilities in control, communication and monitoring of Liebert Precision Cooling units. The Liebert iCOM is a factory-installed assembly. Operating conditions and status are indicated on the display, which is mounted either on the Liebert XDP or on the wall, depending on application details (see user manual, SL-16644). The control system also monitors unit operation and activates an alarm when any of the specified factory preset conditions are exceeded.

The Liebert XDP with Liebert iCOM includes two temperature-humidity sensors to aid in effective cooling.

- CANbus Communication**—The Liebert XDP is able to communicate with Liebert XD smart modules over CANbus. This allows the status of the modules to be viewed from the Liebert XDP Liebert iCOM display. The Liebert XDP is also able to send remote shutdown signals to the smart modules. Liebert XD smart modules are able to provide alarm conditions such as fan failure or condensate detection at the Liebert XDP display.

**Figure 5.14 Liebert XDP dimensions**

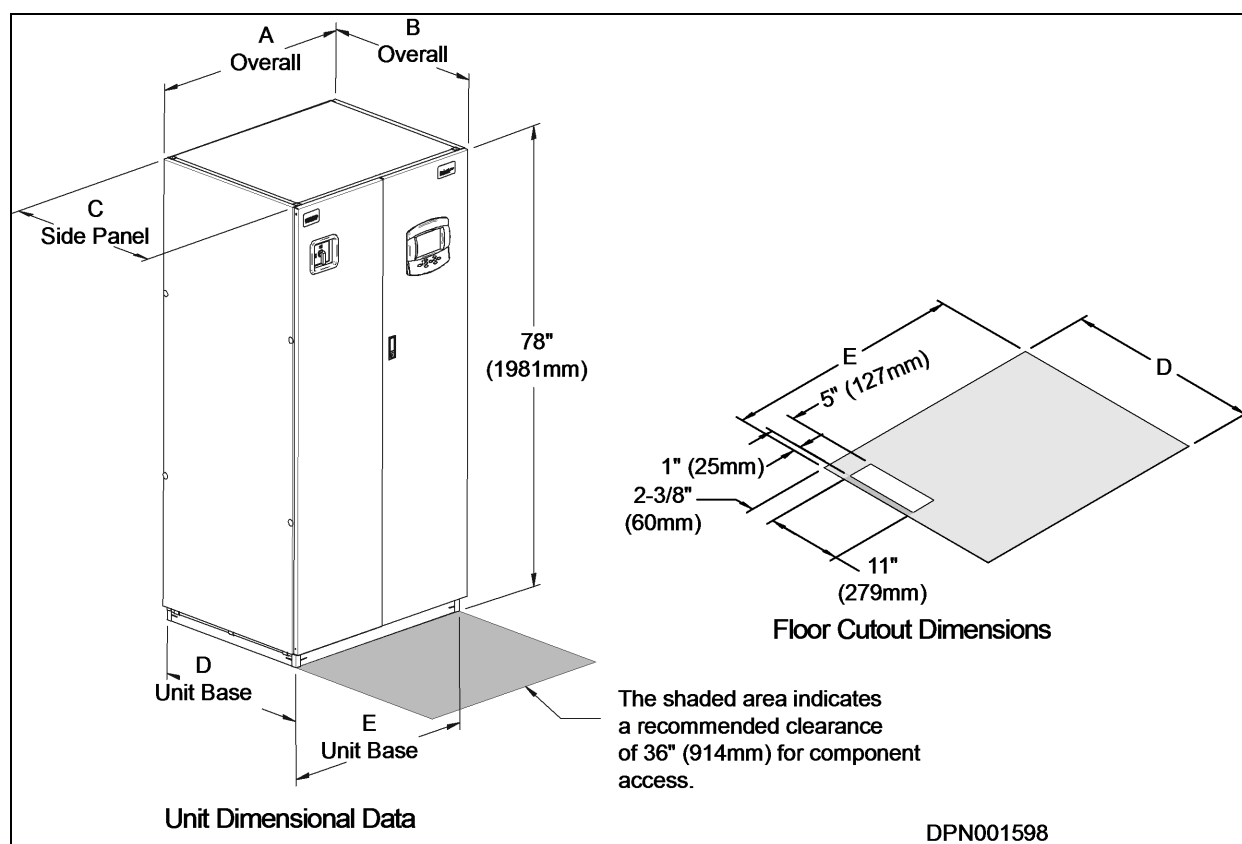
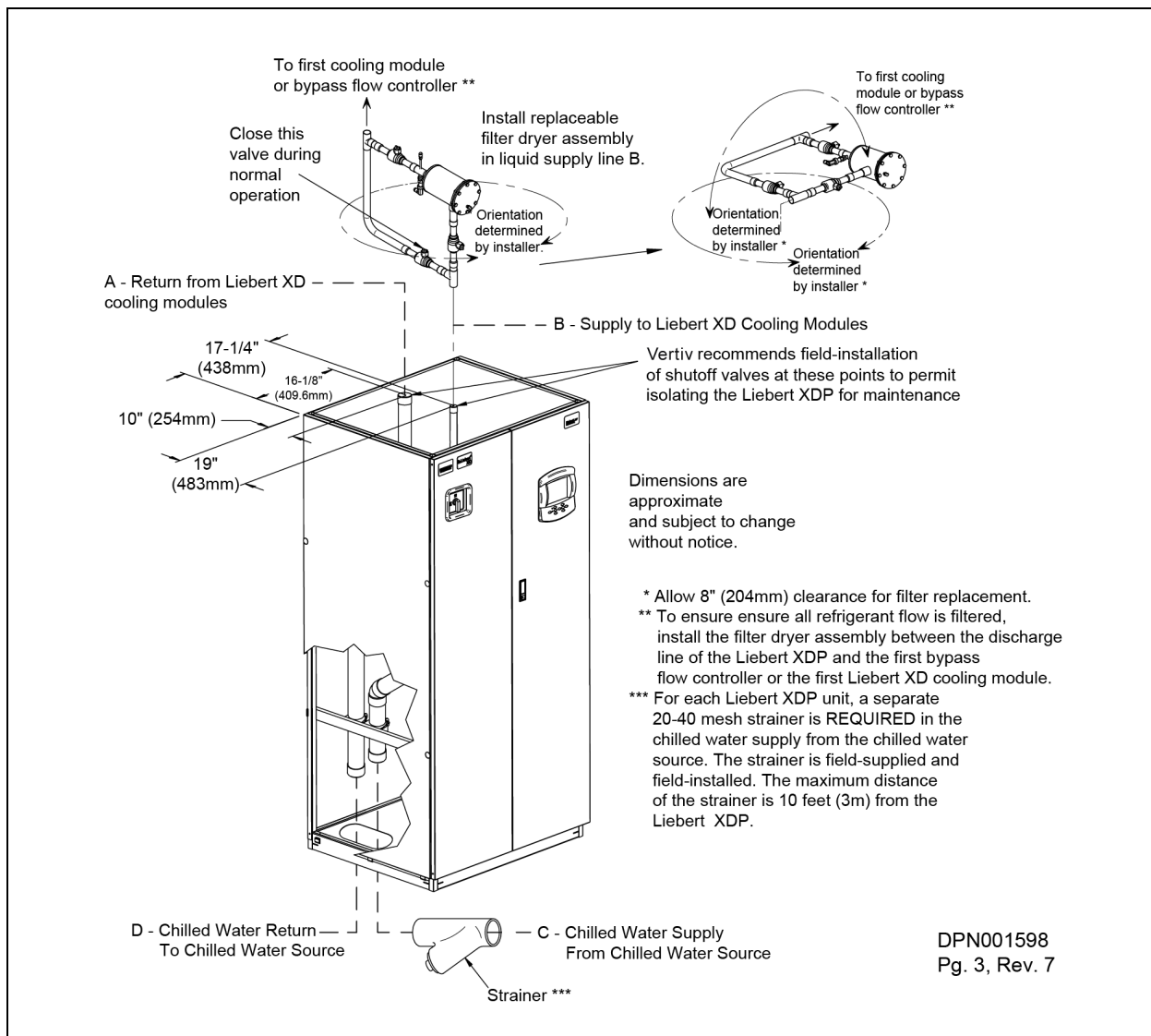

**Table 5.4 Liebert XDP dimensions**

Model	Dimensional Data inches (mm)					Shipping Weight, lb (kg)	
	A	B*	C	D	E	Domestic	Export
Liebert XDP160	38 (965)	34 (864)	33-1/8 (841)	33 (838)	36 (914)	990 (449)	1067 (484)

\* The dimension does not include the bezel of the disconnect switch.

**Figure 5.15 Liebert XDP piping access points and external features**



**Table 5.5 Unit piping outlet connection sizes, inches, OD Cu**

Model	Pipe Connection Point			
	A	B	C	D
Liebert XDP160	2-1/8	1-1/8	2-5/8	2-5/8

Figure 5.16 Front view of Liebert XDP and electrical enclosure

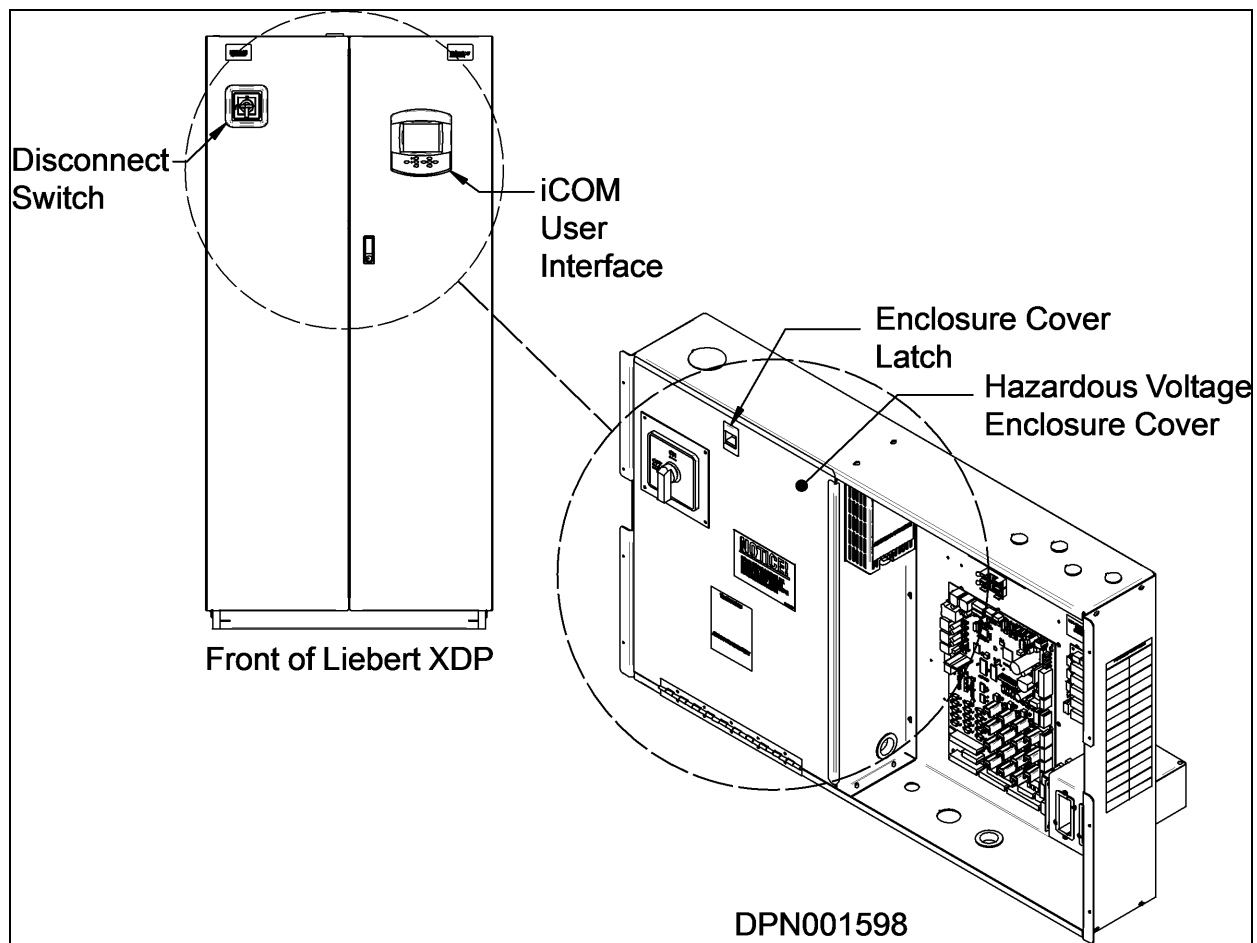

Figure 5.17 Liebert XDP electrical enclosure knockout location for hazardous voltage wiring

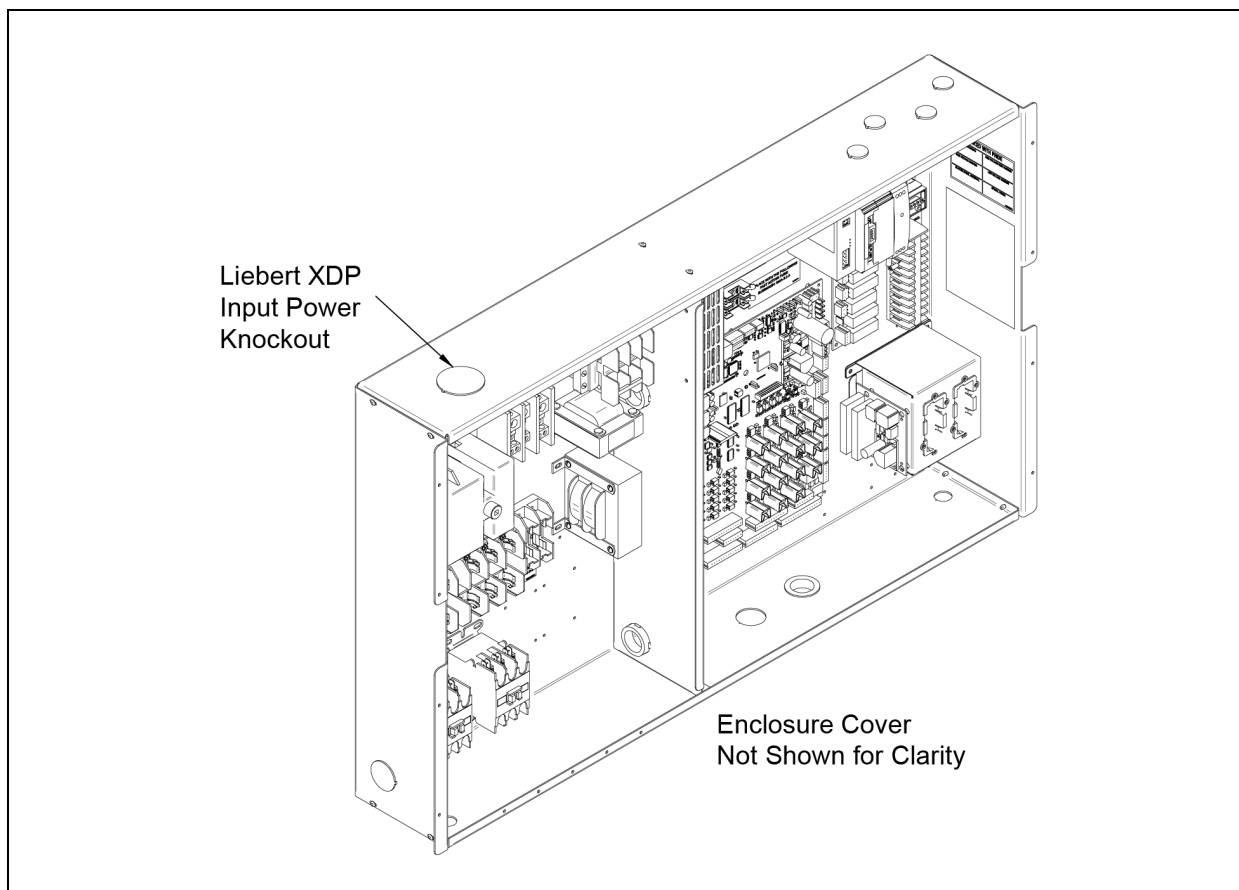

Figure 5.18 Liebert XDP electrical enclosure knockout locations for field wiring

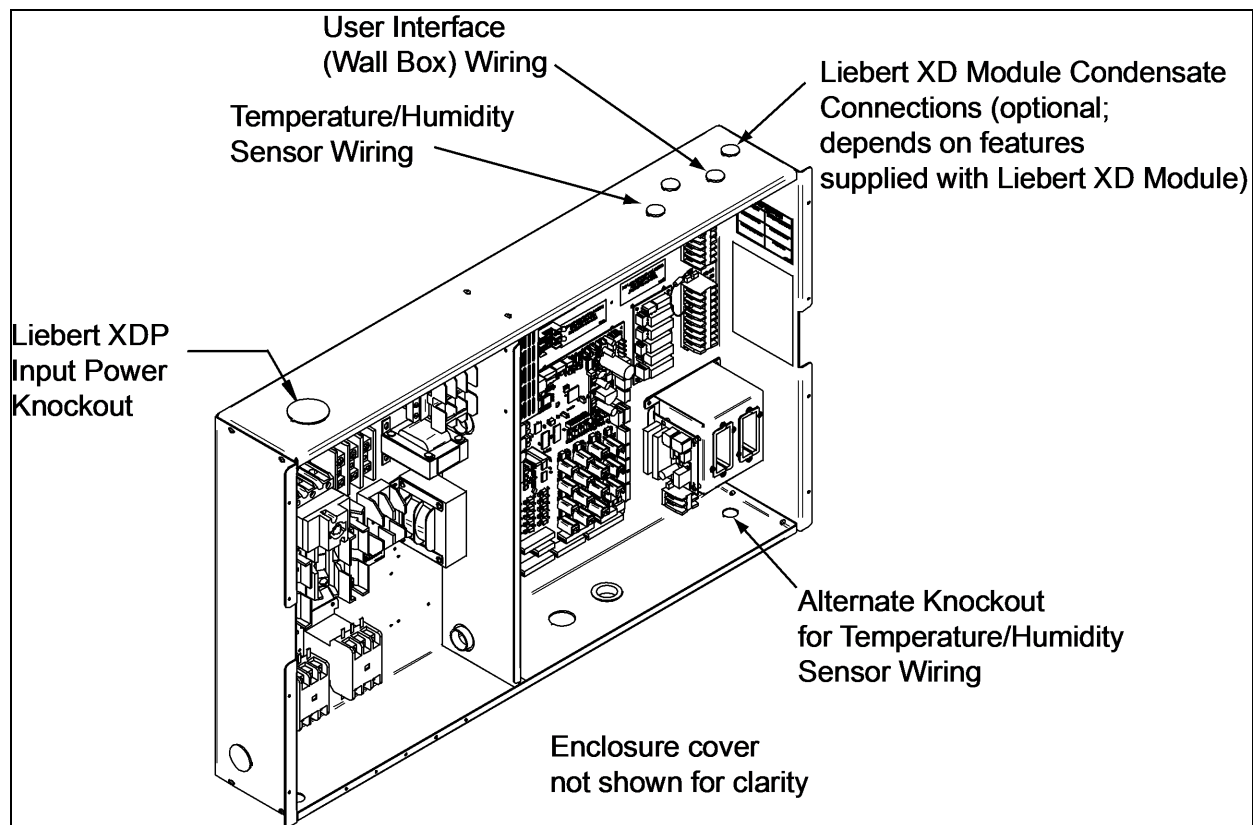



Figure 5.19 Liebert XDP high-voltage connections—60Hz

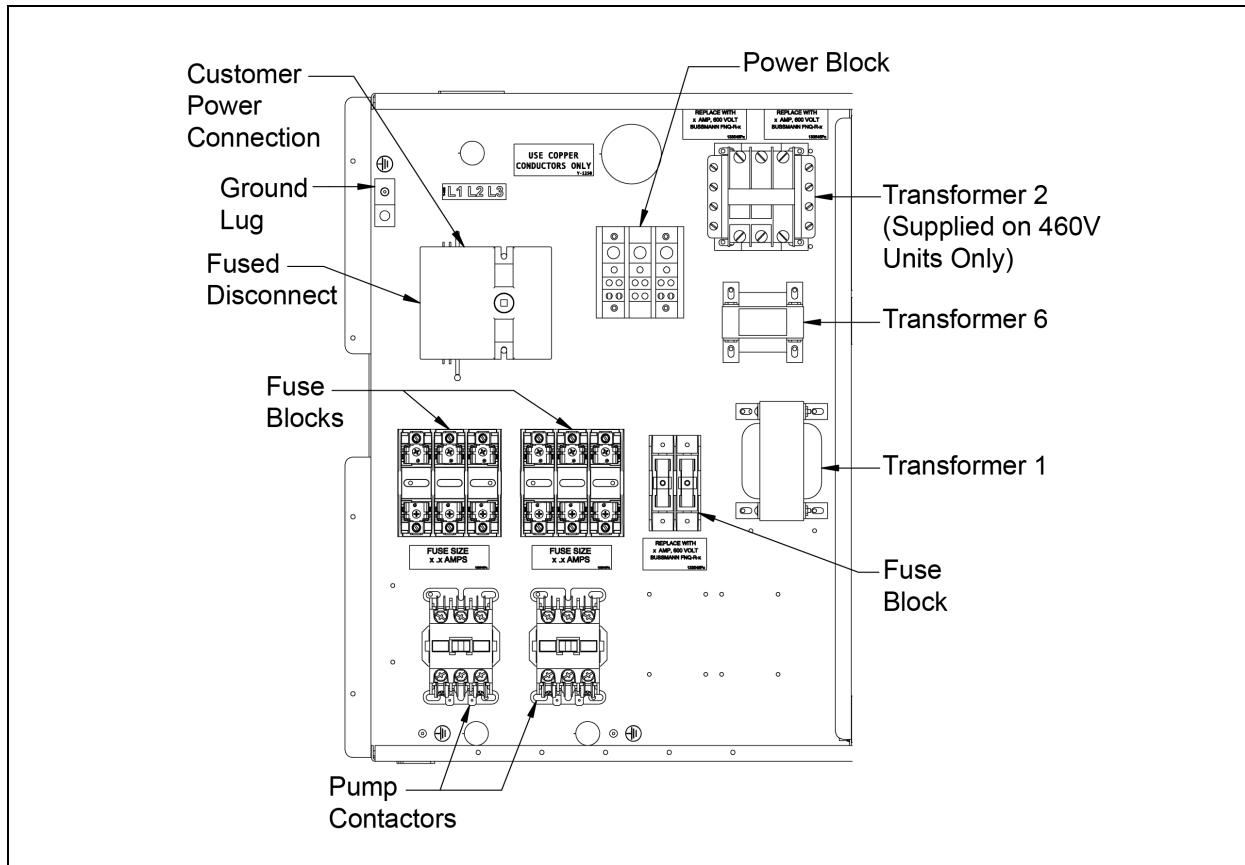
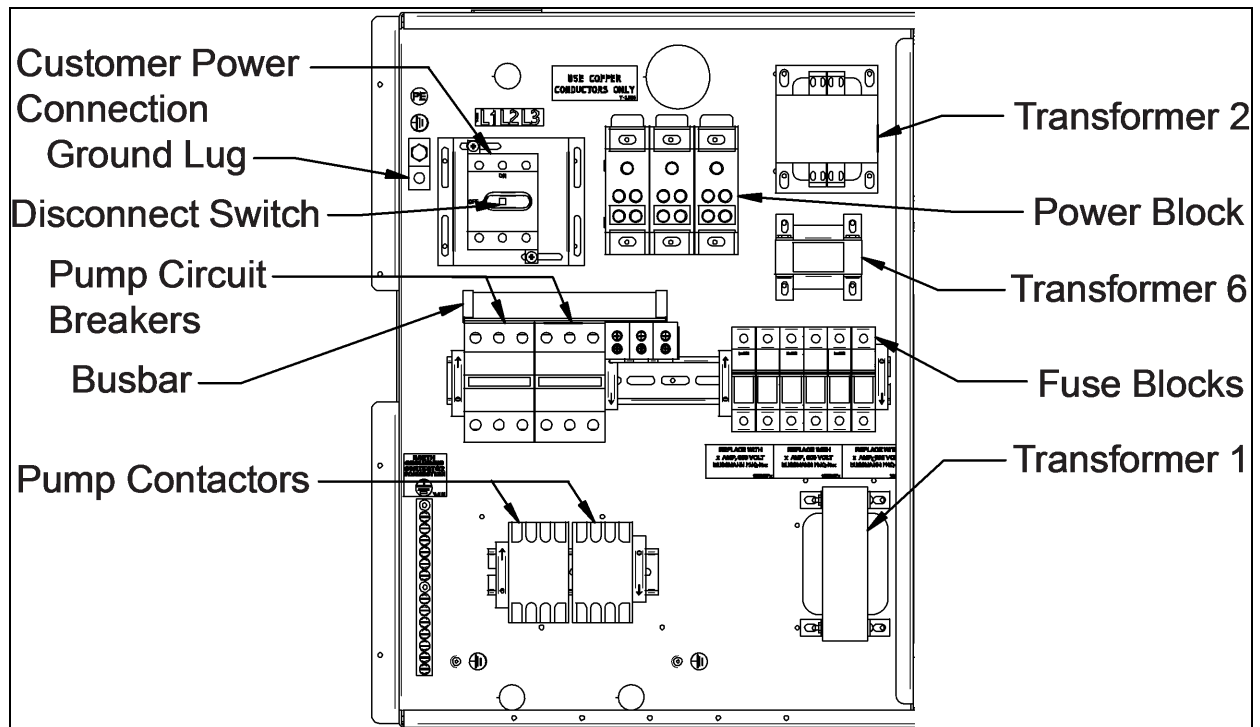

Figure 5.20 Liebert XDP high-voltage connections—50Hz



## 6 HEAT REJECTION

### 6.1 Liebert Lee-Temp™ Refrigerant Control Air-cooled Condensers

The Liebert XDC requires two air-cooled condensers per unit. Each condenser requires one receiver.

#### 6.1.1 Liebert Lee-Temp Refrigerant Control Air-Cooled Condenser

The Liebert Lee-Temp head pressure control system is designed to maintain proper operating head pressures in outdoor temperatures down to -30°F (-34.4°C). The condensers utilize head pressure control valves, extra refrigerant and insulated refrigerant receivers with heater pads. It works by flooding the condenser coil with liquid refrigerant to a level that balances the system condensing requirements with the condenser coil surface available to reject the system heat. During the summer, the system requires the entire condenser coil surface for heat rejection and most of the refrigerant is stored in a receiver. In the winter, the same amount of heat can be rejected by only a fraction of the coil surface. As head pressure begins to fall, the control valve restricts the flow of liquid refrigerant exiting from the condenser. This extra liquid refrigerant reduces the effective condenser surface area available for heat transfer. The head pressure control valve also bypasses hot gas into the receiver to warm the liquid and maintain liquid pressure for proper operation of the expansion valve. Condenser fan controls are either fan cycling on ambient temperature or constant on.

#### 6.1.2 Standard Features-All Condensers

**Table 6.1**

Receivers and head pressure kits for Liebert Lee-Temp condensers

Outdoor Ambient °F (°C)	Condenser Model 50/60Hz	Condenser Qty	Receiver Part #	Receiver Qty	Head Pressure Kit	Head Pressure Kit Qty
-30 to 100 (-34 to 38)	DCSL415	2	185010G2 <sup>1</sup> /G4 <sup>2</sup>	2	179711G1	2
-30 to 105 (-34 to 41)	DCSL616	2	179713G1 <sup>1</sup> /G2 <sup>2</sup>	1	179711G2	2
35 to 105 (2 to 41)	DCSL616	2	181610G2 <sup>1</sup> /G4 <sup>2</sup>	2	179711G1	2
1. 120V heater 2. 230V heater						

Liebert condensers consist of condenser coil(s), housing, propeller fan(s) direct-driven by individual fan motor(s), electrical controls and mounting legs. Liebert air-cooled condensers provide positive refrigerant head pressure control to the Precision Cooling indoor unit by adjusting heat rejection capacity. Various methods are employed to match indoor unit type, minimum outdoor design ambient and maximum sound requirements.

### **6.1.3 Condenser Coil**

Liebert-manufactured coils are constructed of copper tubes in a staggered tube pattern. Tubes are expanded into continuous, corrugated aluminum fins. The fins have full-depth fin collars completely covering the copper tubes, which are connected to heavy wall Type “L” headers. Inlet coil connector tubes pass through relieved holes in the tube sheet for maximum resistance to piping strain and vibration. Coils are either single circuit or dual circuit, depending on the application. The hot-gas and liquid lines are spun shut at the factory and include a factory-installed Schrader valve. Coils are factory leak-tested at a minimum of 300 psig (2068kPag), dehydrated, then filled and sealed with a nitrogen holding charge for shipment.

### **6.1.4 Housing**

The condenser housing is fabricated from bright aluminum sheet and divided into individual fan sections by full width baffles. Structural support members, including coil support frame, motor and drive support, are galvanized steel for strength and corrosion resistance. Aluminum legs are provided for mounting unit for vertical discharge and have rigging holes for hoisting the unit into position. The unit's electrical panel is inside an integral NEMA 3R weatherproof section of the housing.

### **6.1.5 Propeller Fan**

Aluminum propeller fan blades are secured to a corrosion-protected steel hub. Fan guards are heavy gauge, close-meshed steel wire with corrosion resistant PVC finish rated to pass a 675-hour salt spray test. Fans are secured to the fan motor shaft by a keyed hub and dual setscrews. Fan diameter is 26" (660mm) or less. The fans are factory-balanced and run before shipment.

### **6.1.6 Fan Motor**

The condenser's fan motor is a continuous air-over design equipped with rain shield and permanently sealed bearing. Die-formed, galvanized steel supports are used for rigid mounting of the motor.

### **6.1.7 Electrical Controls**

Electrical controls, overload protection devices and service connection terminals are factory-wired inside the integral electrical panel section of the housing. A locking disconnect switch is factory-mounted and wired to the electrical panel and controlled via an externally mounted locking door handle. An indoor unit interlock circuit enables condenser operation whenever indoor unit compressors are active. Only supply wiring and indoor unit interlock wiring are required at condenser installation.

## 6.2 Mechanical Considerations

### 6.2.1 Dimensions

Figure 6.1 Condenser planning dimensional data—Four-fan units

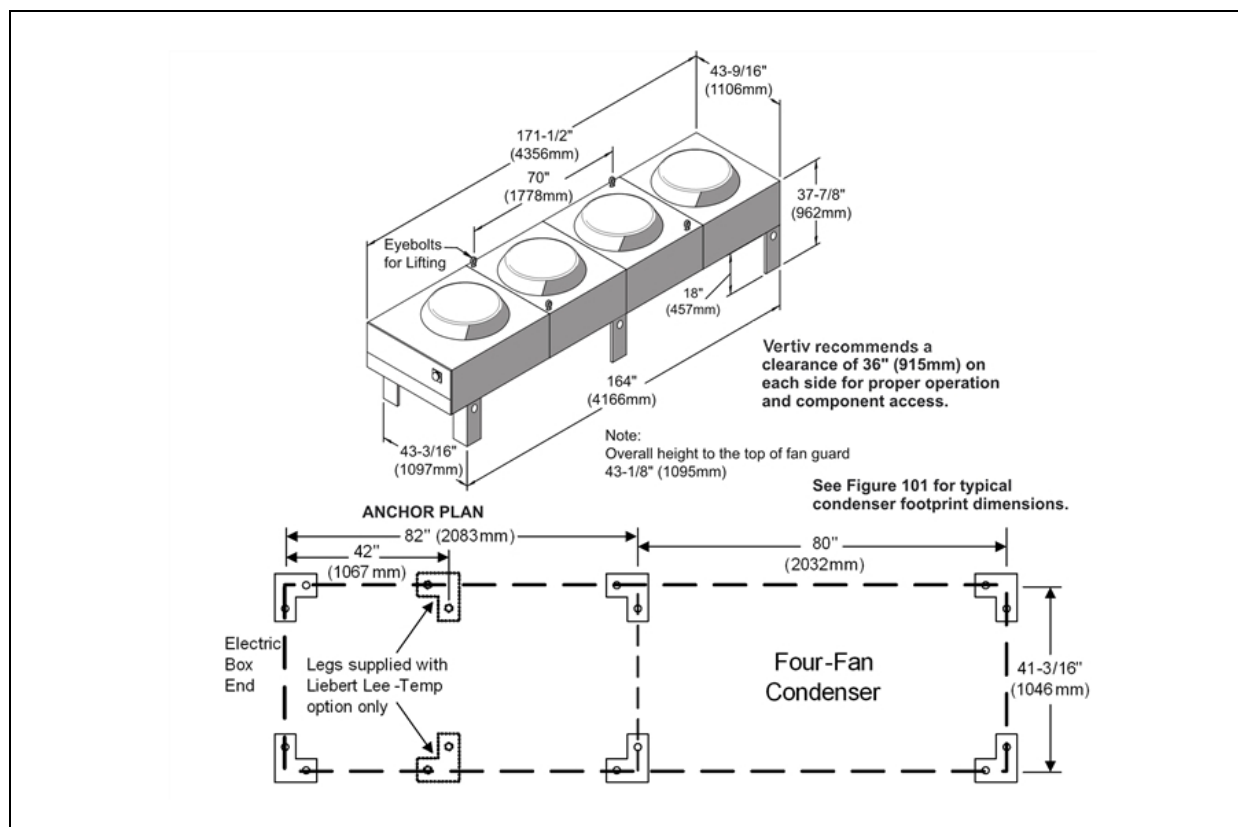

Figure 6.2 Condenser planning dimensional data—Six-fan units

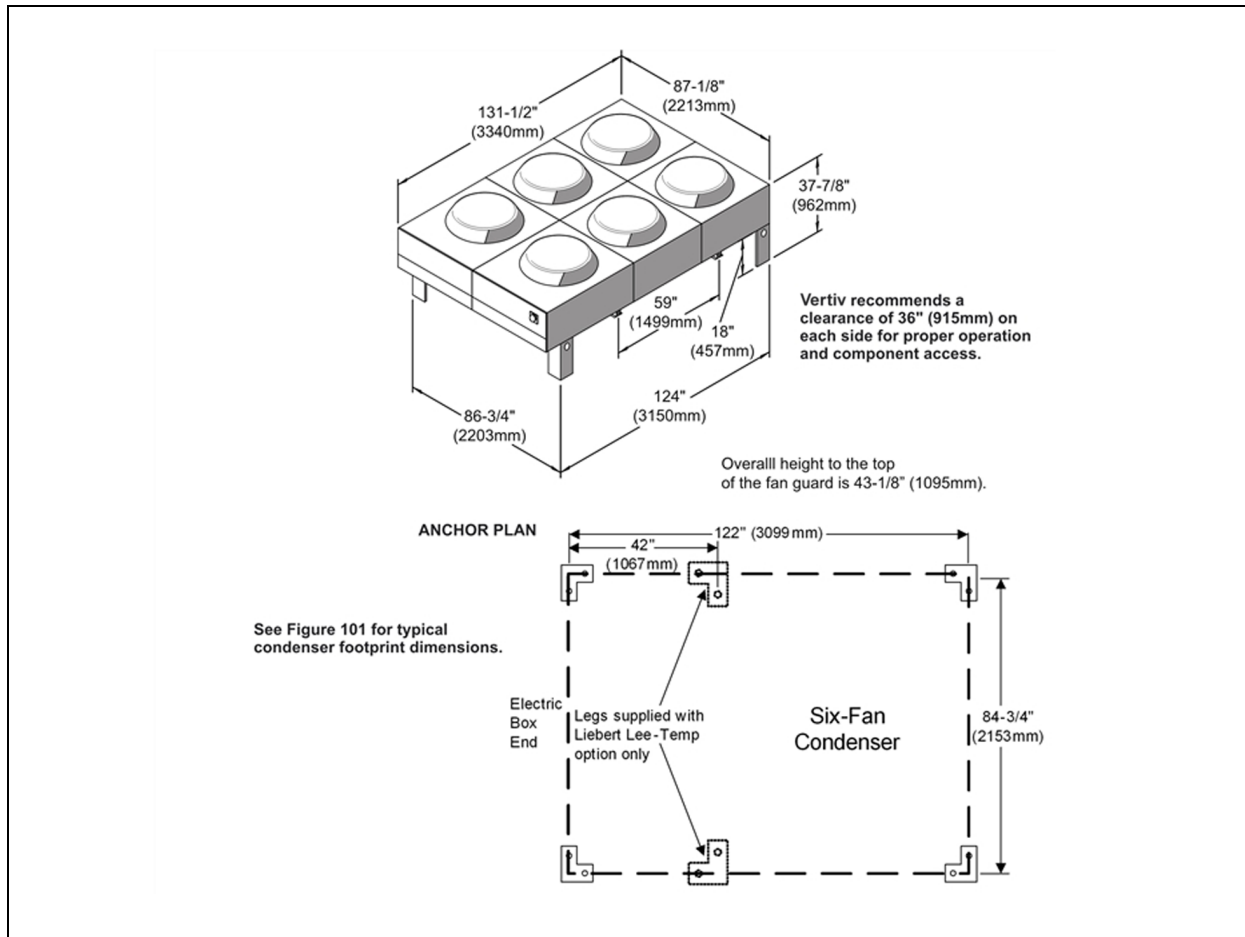
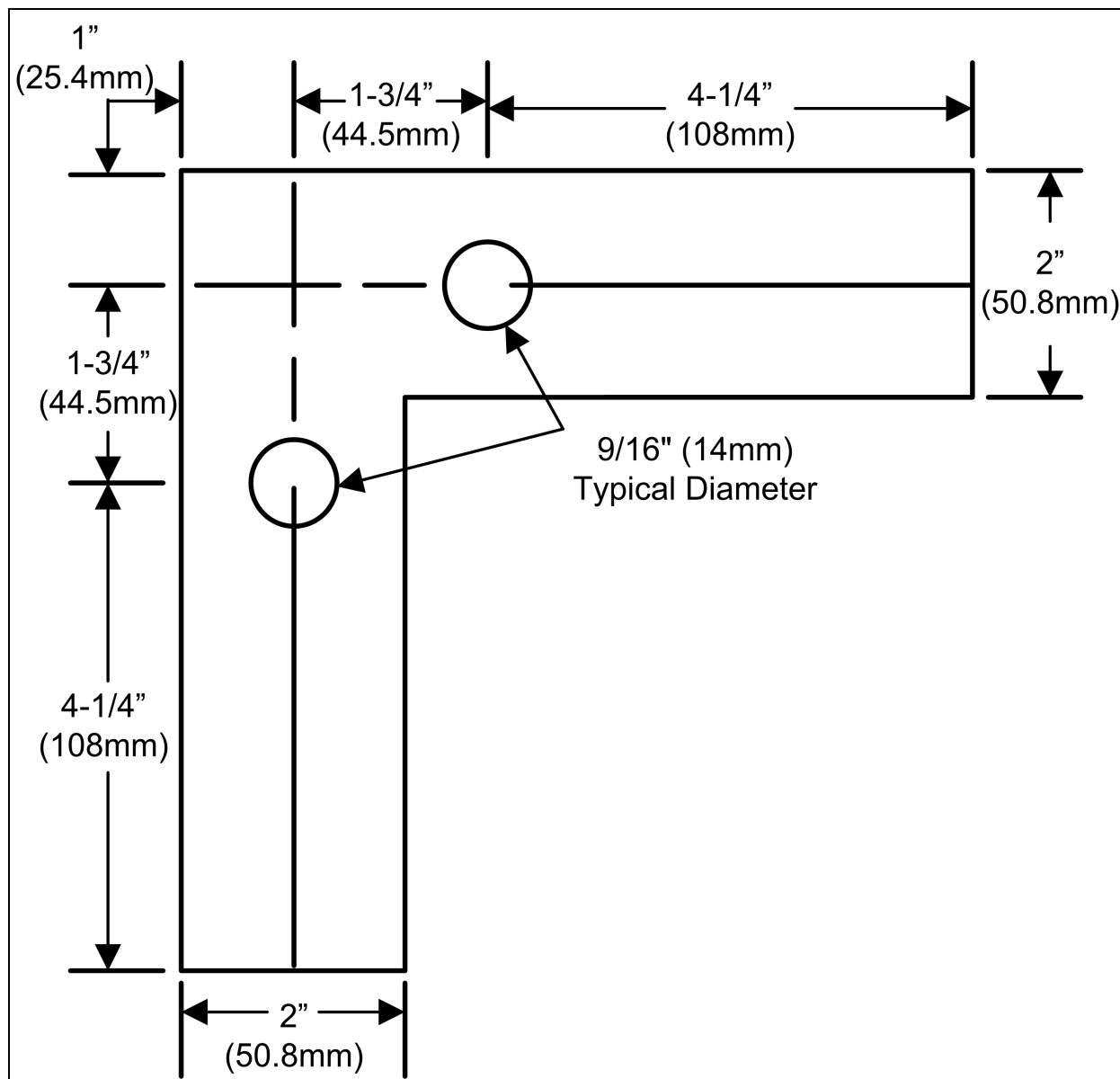

Figure 6.3 Typical condenser footprint—dimensions



**Table 6.2 Condenser weights and connections**

Outdoor Ambient °F (°C)	Model 50/60Hz	Number of Fans	Connection Size, OD, In.		Net Weight lb (kg)	Receiver Part #	Receivers per Condenser	Net Weight lb (kg)
			Hot Gas	Liquid				
-30 to 100 (-34 to 38)	DCSL415	4	1-3/8	1-1/8	840 (381)	<b>185010G2<sup>1</sup>/G4<sup>2</sup></b>	1	260 (118)
-30 to 105 (-34 to 41)	DCSL616	6	(2) 1-5/8	(2) 1-1/8	1380 (626)	<b>179713G1<sup>1</sup>/G2<sup>2</sup></b>	1	424 (192)
35 to 105 (-34 to 41)	DCSL616	6	(2) 1-5/8	(2) 1-1/8	1380 (626)	<b>181610G2<sup>1</sup>/G4<sup>2</sup></b>	1	200 (91)
1. 120V 2. 230V								

**Table 6.3 60Hz electrical condenser data—Liebert Lee-Temp controlled/fan-cycling**

Model #	083, 104, 28K			165, 205, 60K			251, 308, 90K			415, 510			616			830, 1010			
# of Fans	1			2			3			4			6			8			
Input Voltage	ph	FLA	WSA	OPD	FLA	WSA	OPD	FLA	WSA	OPD	FLA	WSA	OPD	FLA	WSA	OPD	FLA	WSA	OPD
208/230	3	3.5	4.4	15	7.0	7.9	15	10.5	11.4	15	14.0	14.9	20	21.0	21.9	25	28.0	28.9	35
460		1.7	2.1	15	3.4	3.8	15	5.1	5.5	15	6.8	7.2	15	10.2	10.6	15	13.6	14.0	20
575		1.4	1.8	15	2.8	3.2	15	4.2	4.6	15	5.6	6.0	15	8.4	8.8	15	11.2	11.6	15
FLA = Full Load Amps; WSA = Wire Size Amps; OPD = Maximum Overcurrent Protection Device																			

**Table 6.4 50 Hz condenser full load amp values**

Condenser Control Type		Liebert Lee Temp Controlled/Fan-Cycling	
Model #	# of Fans	Input Voltage - Phase	
		200/230-3	380/415-3
415	4	14.0	6.8
616	6	21.0	10.2

**Table 6.5 Liebert Lee-Temp receiver electrical data, 50Hz and 60Hz**

Rated Voltage - Single Phase	120			200/208/230		
Watts/Receiver	150	300	450	150	300	450
Full Load Amps	1.4	2.8	4.2	0.7	1.4	2.1
Wire Size Amps	1.8	3.5	5.3	0.9	1.8	2.7
Maximum Overcurrent Protection Device, Amps	15	15	15	15	15	15
The Liebert Lee-Temp receiver requires a separate power feed for heaters. The condenser is not designed to supply power to the receiver.						



## 6.3 Heat Rejection Piping

### 6.3.1 Piping for Direct Expansion (DX) Circuit—R-407C Air-Cooled Units

Risk of refrigerant system explosion or rupture from overpressurization. Can cause equipment damage, injury or death.



**WARNING!** Installer must install a 400 psig pressure relief valve in each of the two R-407C refrigerant circuits of the Liebert XDC system. Do not install shutoff valves between the compressors and the pressure relief valves.

For systems requiring EU CE compliance, the pressure relief valves must be CE-certified by a notified body to the EU Pressure Equipment Directive.

## 6.4 Install Double Discharge Risers

For air-cooled systems, double discharge risers must be installed in the hot gas lines that have vertical heights of 15 feet (4.6m) or more (see Figure 6.4 on the next page). This will allow proper oil return to the compressors when the system is running at low loads. A double riser system is constructed of a large diameter riser with a trap at the base and a riser with a smaller diameter in parallel.

At full-load operation, the refrigerant vapor flows up both risers at velocities that are adequate to carry the oil. At low loads, refrigerant vapor velocities are lower and the trap at the bottom of the riser becomes filled with oil. When this happens, refrigerant flows up only the smaller riser.

The trap at the top of the riser must be tied into the top of the line to prevent oil from filling the larger riser. For each double riser used, the maximum height of the riser must not exceed 15 feet (4.6m). Multiple risers must be installed in series as the height of the hot gas line increases. Total maximum height of the hot gas line must not exceed 60 feet (18.3m).

Horizontal discharge lines should be pitched downward in the direction of flow to aid in oil drainage with downward pitch of at least 1/2 inch in 10 feet (13mm in 3m).

Figure 6.4 Double discharge riser layout

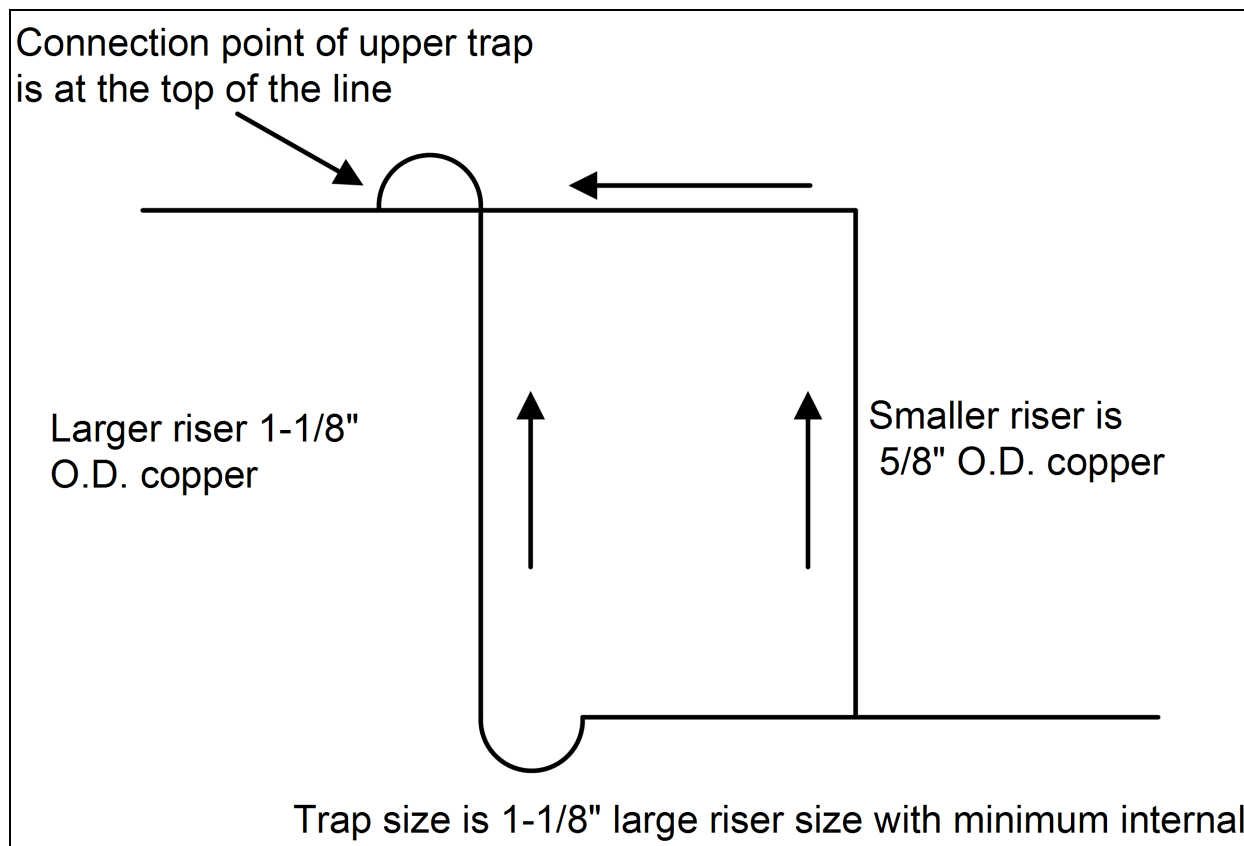

Contact your local Liebert representative for factory approval whenever a refrigerant piping run exceeds 200 feet (60m) equivalent length or when condensers must be installed below the level of the cooling coil.

For Air-Cooled Liebert Lee-Temp / Flood Back Head Pressure Control Units Only



**WARNING! Risk of explosive discharge from high-pressure refrigerant. Can cause injury or death.**

**This unit contains fluids and/or gases under high pressure.**

**Relieve pressure before working with piping.**

#### NOTICE

Risk of refrigerant contamination. Can cause equipment damage and operational problems.

Refrigerant R-407C is a blend of three components and must be introduced and charged from the cylinder only as a liquid.

Refrigerant R-407C uses a POE (polyolester) lubricant. Do not open the compressor unit piping to the atmosphere for more than 15 minutes. The compressors contain POE oil that is very hygroscopic; it quickly absorbs water from the atmosphere. The longer the compressor piping is open to the atmosphere, the harder it will be to fully evacuate. If left open too long, the POE oil may need to be replaced before achieving the required vacuum level.

POE oils also have a property that makes them act as a solvent in a refrigeration system. Maintaining system cleanliness is extremely important because the oil will tend to bring any foreign matter back to the compressor. Refer to the ASHRAE refrigeration handbook for general good-practice refrigeration piping.

**Table 6.6 Receivers and head pressure kits for Liebert Lee-Temp condensers**

Outdoor Ambient °F (°C)	Condenser Model 50/60Hz	Condenser Qty	Receiver Part #	Receiver Qty	Head Pressure Kit	Head Pressure Kit Qty
-30 to 100 (-34 to 38)	D CSL415	2	185010G2 1/G4 <sup>2</sup>	2	179711G1	2
-30 to 105 (-34 to 41)	D CSL616	2	179713G1 <sup>1</sup> /G2 <sup>2</sup>	1	179711G2	2
35 to 105 (2 to 41)	D CSL616	2	181610G2 <sup>1</sup> /G4 <sup>2</sup>	2	179711G1	2
1. 120V heater 2. 230V heater						

Figure 6.5 Installation data—Liebert Lee-Temp, one-circuit, four-fan model

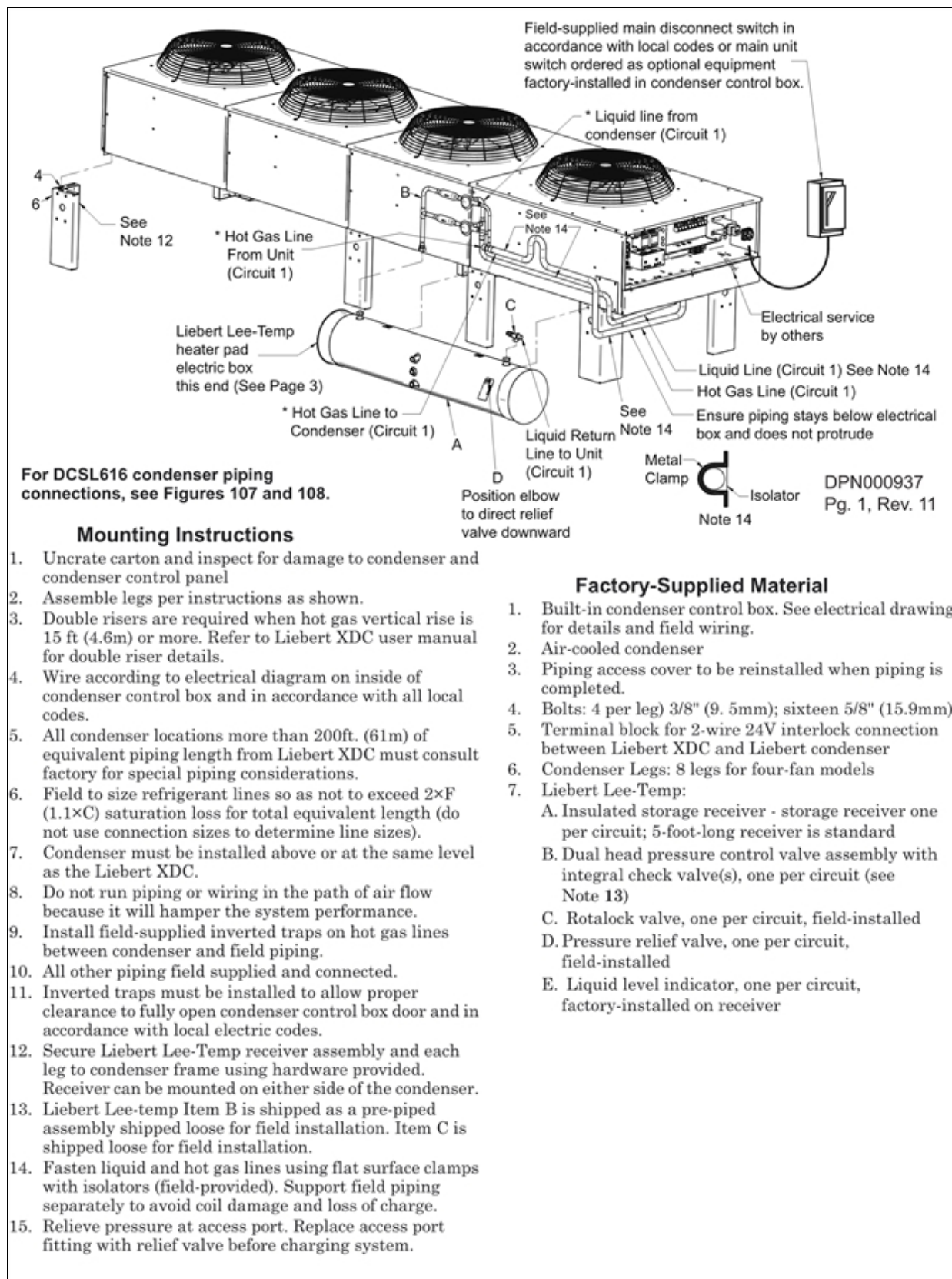

Figure 6.6 Installation data—Liebert Lee-Temp, one-circuit, high ambient six-fan model

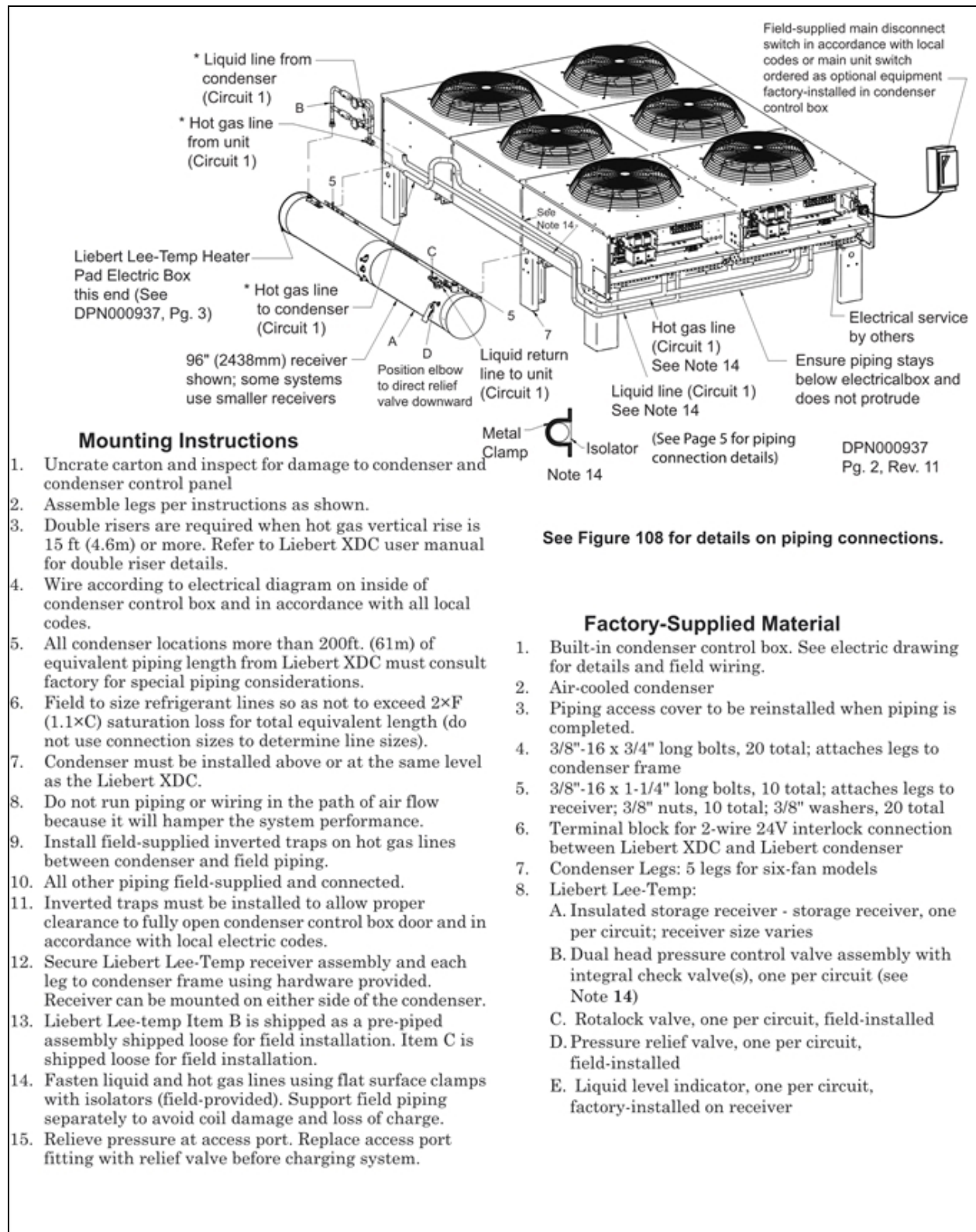

Figure 6.7 Liebert XDC piping schematic and Liebert Lee-Temp heater pad wiring

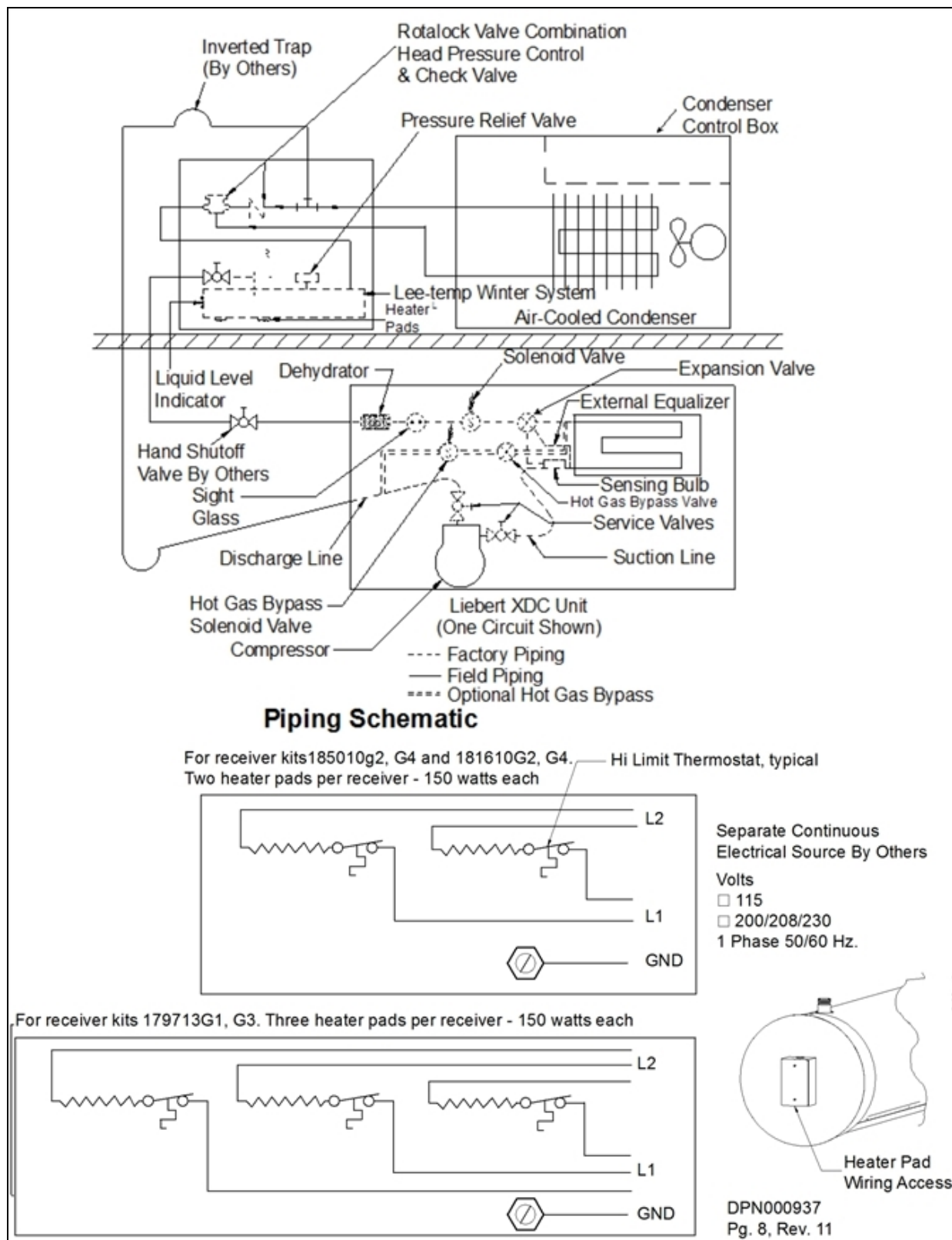
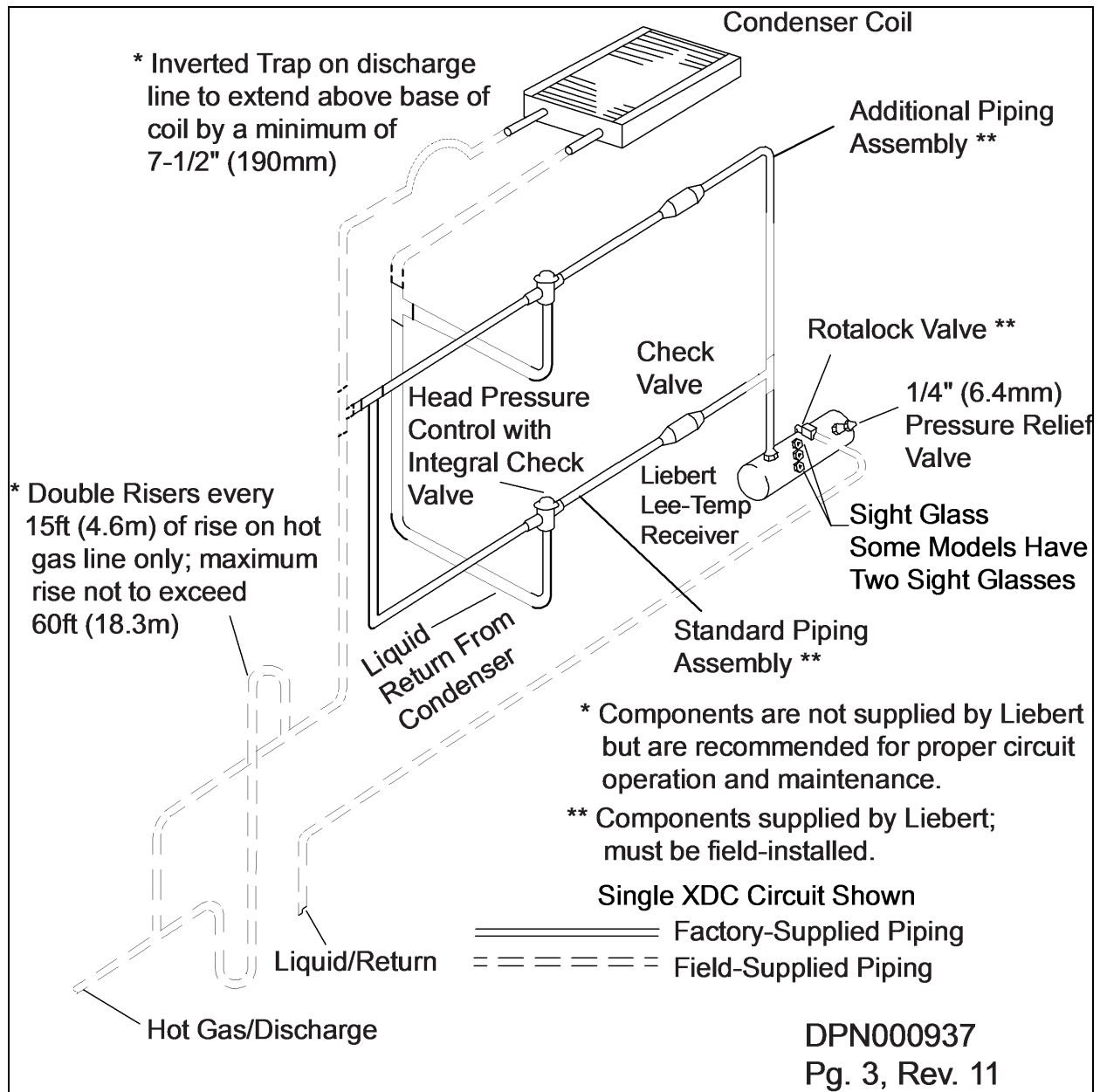



Figure 6.8 General arrangement air-cooled Liebert XDC Liebert Lee-Temp Control



**Table 6.7 Recommended refrigerant line sizes, DX R-407C, OD copper**

Liebert XDC 160			
Equivalent Length, ft., (m)	*Hot Gas Line, in.	Liquid Line, in.	
50 (15)	1-1/8	7/8	
100 (30)	1-1/8	1-1/8	
150 (45)	1-3/8	1-1/8	
200 (60)	1-3/8	1-1/8	

\* Double risers are required when hot gas vertical rise is 15ft. (4.6m) or more.  
 Source: DPN000937, Pg. 3, Rev. 11



Figure 6.9 DCSL616 piping connections—two refrigerant circuits connected for parallel flow

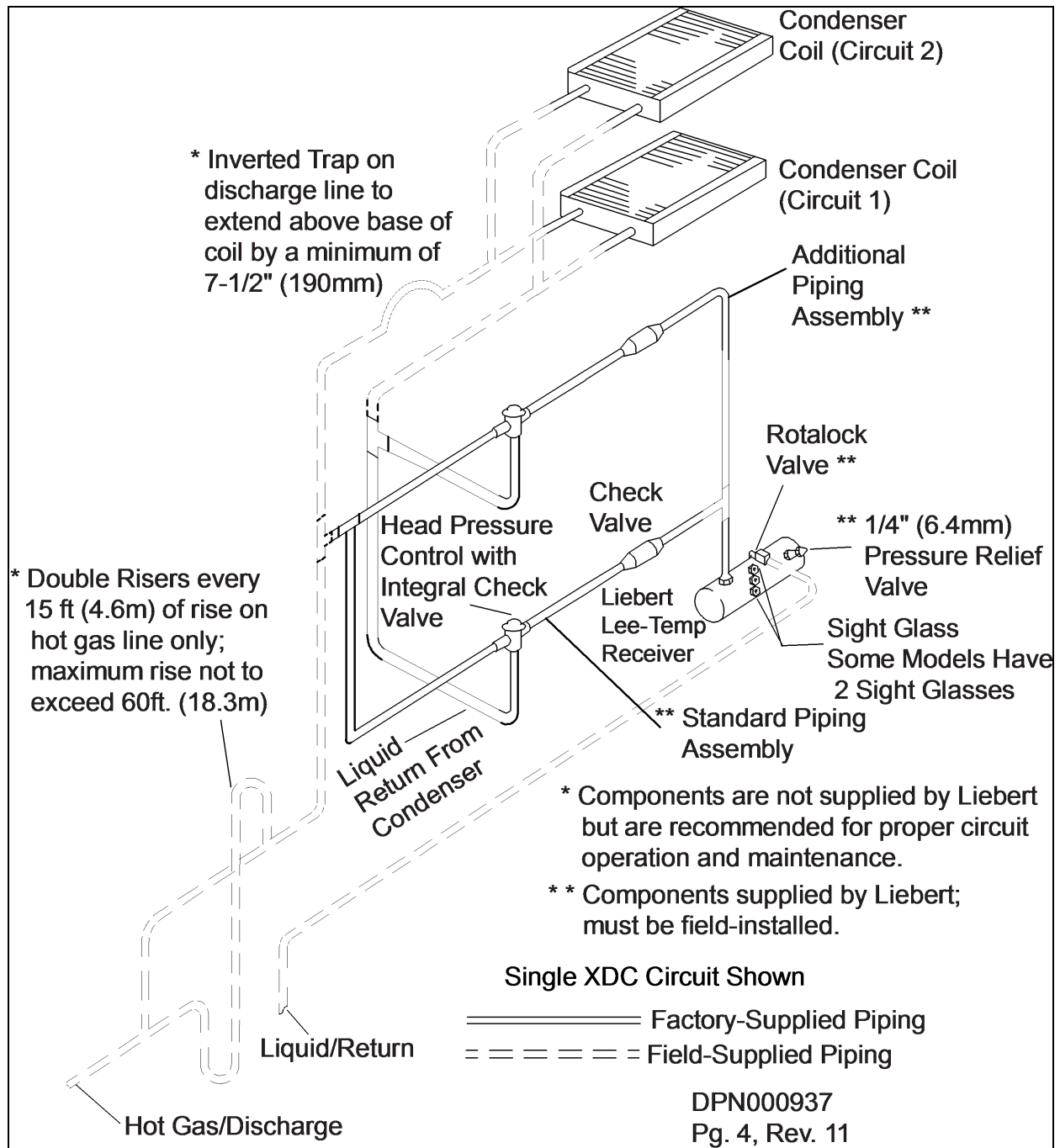
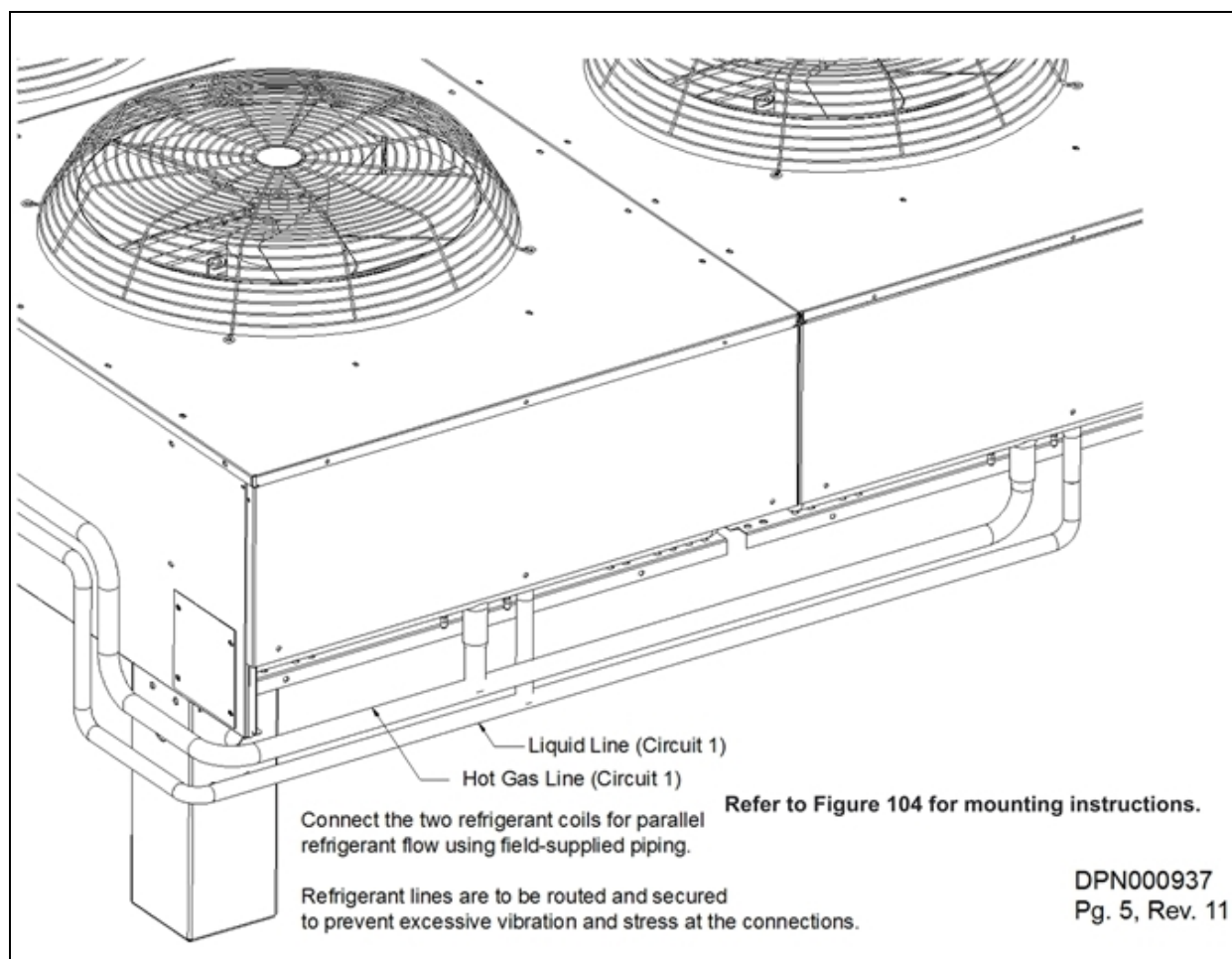

**Table 6.8 Recommended refrigerant line sizes for DCSL616**

Liebert XDC 160			
Equivalent Length, ft., (m)	*Hot Gas Line, in.	Liquid Line, in.	
50 (15)	1-1/8	7/8	
100 (30)	1-1/8	1-1/8	
150 (45)	1-3/8	1-1/8	
200 (60)	1-3/8	1-1/8	

\* Double risers are required when hot gas vertical rise is 15 feet or more.  
 Source: DPN000937, Pg. 4, Rev. 11

**Figure 6.10 DCSL616 piping connections—two refrigerant circuits connected for parallel refrigerant flow**



### 6.4.1 Air-Cooled Condenser with Liebert Lee-Temp “Flooded Condenser” Head Pressure Control System—R-407C (DX) Circuit

The Liebert Lee-Temp system consists of a modulating type head pressure control valves and insulated receivers with heater pads to ensure operation at ambient temperatures as low as -30°F (-34.4°C).

## 6.5 Calculating Refrigerant Volume

Using Table 6.9 below, Table 6.10 below and Table 6.11 below or Table 6.12 below, calculate the refrigerant charge of the individual sections of the heat rejection system. Add the calculated charge amounts to determine the amount of R-407C refrigerant required for one system.

**Table 6.9 Indoor unit refrigerant charge—R-407C**

Model 50/60 Hz	Charge/Circuit, lb. (kg)
Liebert XDC160	17.5 (8.0)

**Table 6.10 Outdoor air condenser charge—R-407C**

Outdoor Ambient, °F (°C)	Model 50/60 Hz	Receiver Part #	Charge / Circuit, lb. (kg)
-30 to 100 (-34 to 38)	DCSL415	185010G2 below / G4 below	200 (91)
-30 to 105 (-34 to 41)	DCSL616	179713G1 below / G2 below	254 (115)
35 to 105 (2 to 41)	DCSL616	181610G2 below / G4 below	164 (75)
120V			
230V			

**Table 6.11 Air-cooled systems - liquid line charge - R-407C refrigerant per 100ft (30m) of Type ACR copper tube**

O.D., inches	Liquid Line, lb. (kg)	Hot Gas Line, lb. (kg)
3/8	3.7 (1.7)	-
1/2	6.9 (3.1)	-
5/8	11.0 (5.0)	2.2 (1.0)
3/4	15.7 (7.1)	3.1 (1.4)
7/8	23.0 (10.4)	4.5 (2.0)
1-1/8	39.3 (17.8)	7.8 (3.5)
1-3/8	59.8 (27.1)	11.8 (5.4)
1-5/8	—	16.7 (7.6)

**Table 6.12 Indoor water/glycol-cooled module – R-407C refrigerant charge**

Model 60 Hz	Charge / Circuit, lb. (kg)
Liebert XDC 160	30.0 (13.2) per circuit

### 6.5.1 Liebert XDC DX R-407c Circuit Volume

#### NOTICE

Risk of improper lubrication. May cause equipment damage.

Liebert XDCs' refrigerant R-407c circuits with refrigerant charges over 55 lb (24.9 kg) require additional oil. See Figure 6.11 below for the amount required for various charge levels.

Once the system has been fully charged with refrigerant, use a hand pump to add the additional oil at the suction side of the system while the system is running.

The amount of oil added by field service must be recorded on a tag attached at the tandem the amount added along with the date it was added. This will be documented on a tag located at the tandem compressor and marked "Oil Added Field Service Record." Refer to the Liebert XDC user manual, SL-16674, available at [www.VertivCo.com](http://www.VertivCo.com).

Figure 6.11 Additional oil requirements for refrigerant charge

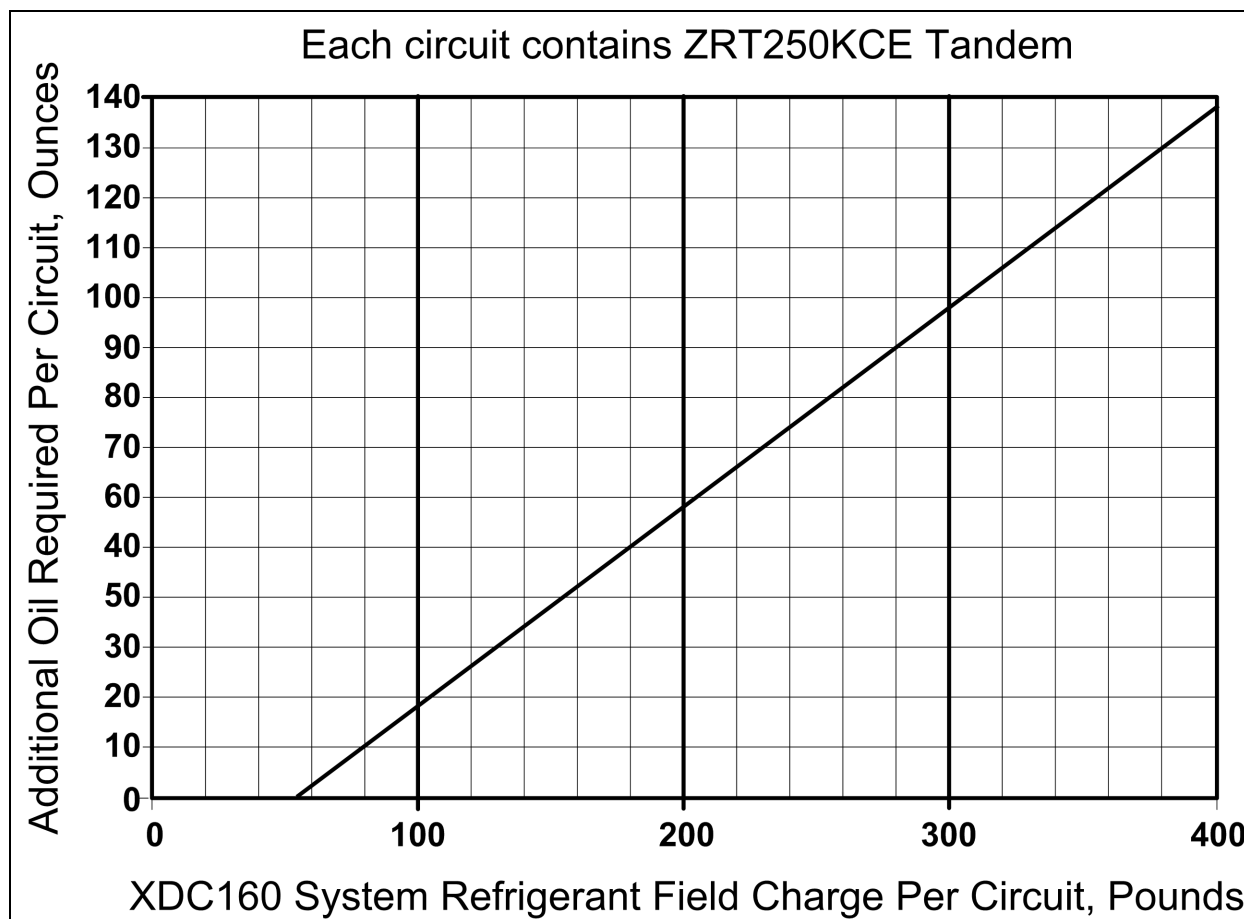

To calculate the oil required, use the following formula:

$$\text{Additional Oil Required per Circuit} = (\text{Refrigerant Charge} * 0.4 - 22)$$

Enter the refrigerant charge in pounds to determine the oil required in ounces

## NOTICE

Risk of improper compressor lubrication. Can cause compressor and refrigerant system damage. Failure to use oil types, viscosities and quantities recommended by the compressor manufacturer may reduce compressor life and void the compressor warranty.

- Do not mix polyol ester (POE) and mineral-based oils.
- Do not mix oils of different viscosities.

Consult Vertiv Technical Support or the compressor manufacturer if questions arise.

## 6.6 Liebert Drycoolers

The Liebert drycooler is a low-profile, direct-drive propeller fan-type air cooled unit. Constructed with an aluminum cabinet and a copper-tube aluminum fin coil, the unit is quiet and corrosion resistant. All electrical connections and controls are enclosed in an integral NEMA 3R rated electrical panel section of the drycooler.

### 6.6.1 Liebert Drycooler Fan Cycling Control

Available on all sizes of standard sound and Quiet-Line drycoolers. A thermostatic control cycles the fan on a single-fan drycooler in response to leaving fluid temperatures. Two or more thermostats are employed on drycoolers with two or more fans to cycle fans or groups of fans in response to leaving fluid temperatures. The thermostat setpoints are listed on the factory-supplied schematic. They typically range from 35 to 45°F (2 to 7°C) for GLYCOOL applications and 65 to 75°F (18 to 24°C) for glycol applications.

### 6.6.2 Pump Controls

Controls for pump(s) up to 7.5hp are built into the same integral electric panel as the drycooler fan controls. Pump fuses, overload heaters and flow switch (dual pump control models) are included with the Liebert pump packages or must be field-supplied for field-supplied pumps.

Dual pump option—Provides controls for primary and standby pump. The flow switch senses loss of flow and switches to the standby pump for continuous system operation in the event of a pump failure. An internal switch allows manual selection of the lead/lag pump.

## 6.7 Typical System configurations

The standard glycol-cooled precision air conditioning system includes these major components:

- indoor air conditioning unit with heat exchangers (refrigerant/glycol)
- glycol regulating valve
- outdoor air cooled drycooler
- glycol pump(s)
- expansion/compression tank
- pump controls
- interconnection piping
- unit interlock control wiring

Figure 6.12 on the next page shows a typical configuration of multiple indoor units and multiple outdoor drycoolers using a dual pump package and on a common piping loop.

Additional field-supplied components, such as valves, expansion tank, strainers and flow or pressure switches are also shown in Figure 6.12 below. These components are necessary and should be included when designing a system with one indoor and one outdoor unit on a piping loop or a system using multiple indoor and outdoor units on a common piping loop. Larger systems may also benefit from an air separator (not shown). Refer to SL-10080, available at [www.VertivCo.com](http://www.VertivCo.com) for further details on required components.

**Figure 6.12 Typical piping arrangement for Liebert XDC and two DDNT880A**

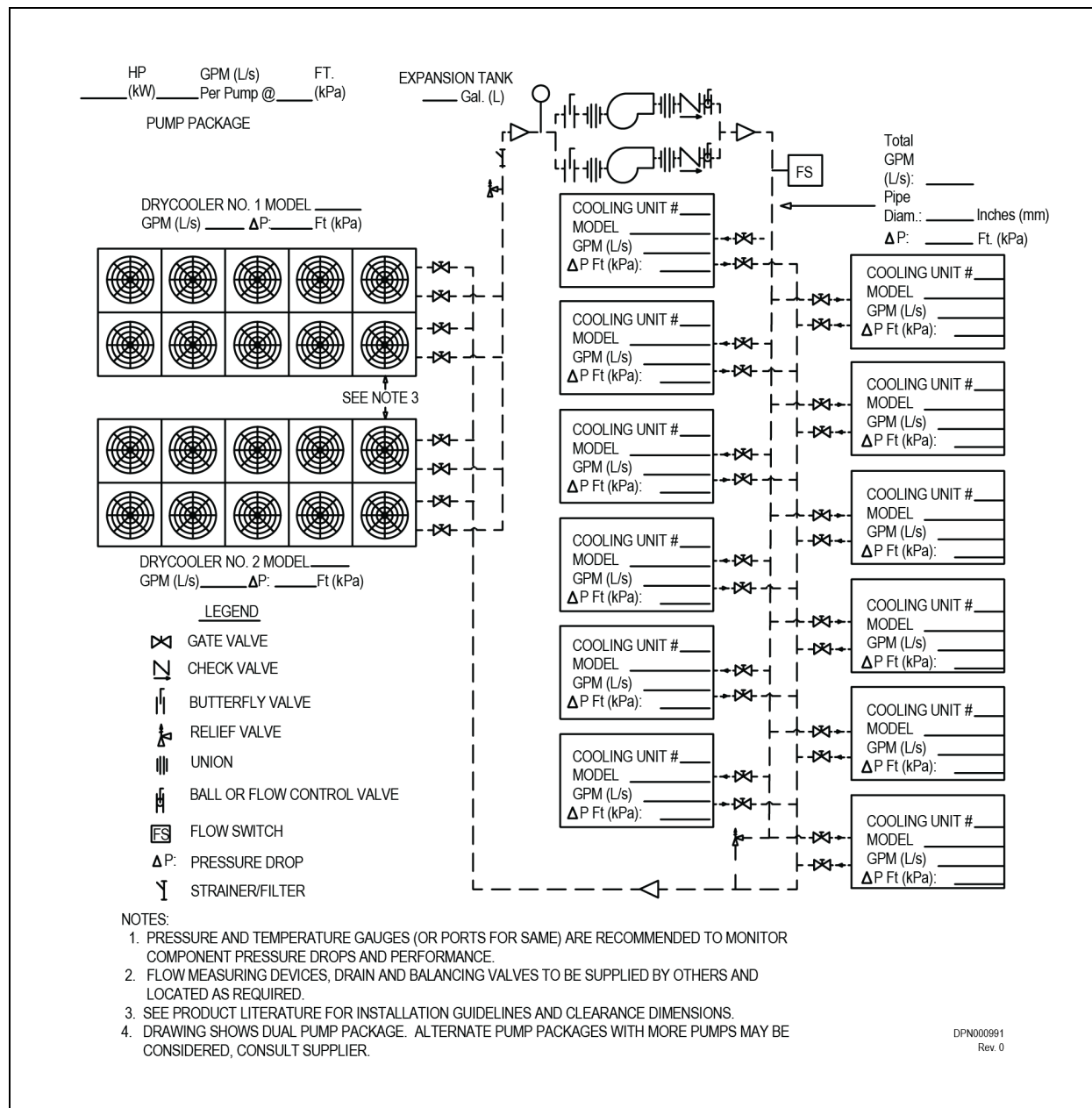

## 6.8 Site Considerations

The drycoolers and pumps should be installed in a location offering maximum security and access for maintenance.

Avoid ground level sites with public access and areas that contribute to heavy snow or ice accumulations. Utilize Piggyback drycoolers whenever interior building locations must be used. To ensure adequate air supply, Vertiv recommends that the drycoolers be located in an area with clean air, away from loose dirt and foreign matter that may clog the coil. In addition, drycoolers should not be located near steam, hot air or fume exhausts. Drycoolers must not be installed in a pit, where discharge air is likely to be recirculated through the drycooler or installed where objects restrict the air inlet free area. Also, the drycoolers should be located no closer than 3 feet (1m) from a wall, obstruction or adjacent unit (see Figure 6.13 on the next page).

The drycooler must be installed on a level surface to ensure proper glycol flow, venting and drainage.

For roof installation, mount the drycooler on suitable curbs or other supports in accordance with local codes.

Allow adequate space for pump packages, expansion/compression tanks, piping and additional field supplied devices.

When mounting pump packages, mount on level surface or suitable curbs that will allow cooling ventilation air to enter from underneath the pump package frame and exit through the louvers.

## 6.9 Dimensions and Weights

**Table 6.13**

Standard drycooler net weights, shipping weights, dimensions and volume, approximate

Model	No. of Fans	Net Weight lb (kg)	Domestic Packaging			Export Packaging		
			Packaged Weight lb (kg)	Dimensions L x W x H in (cm)	Volume ft <sup>3</sup> (m <sup>3</sup> )	Packaged Weight lb (kg)	Dimensions L x W x H in (cm)	Volume ft <sup>3</sup> (m <sup>3</sup> )
*D**880	8	2330 (1058)	2730 (1239)	184 x 37 x 97	382	3230 (1446)	185 x 38 x 97	395
*D**940		2430 (1103)	2910 (1321)	(467 x 94 x 246)	(10.8)	3410 (1548)	(470 x 97 x 246)	(11.2)

Figure 6.13 Drycooler planning dimensional data—Eight-fan units

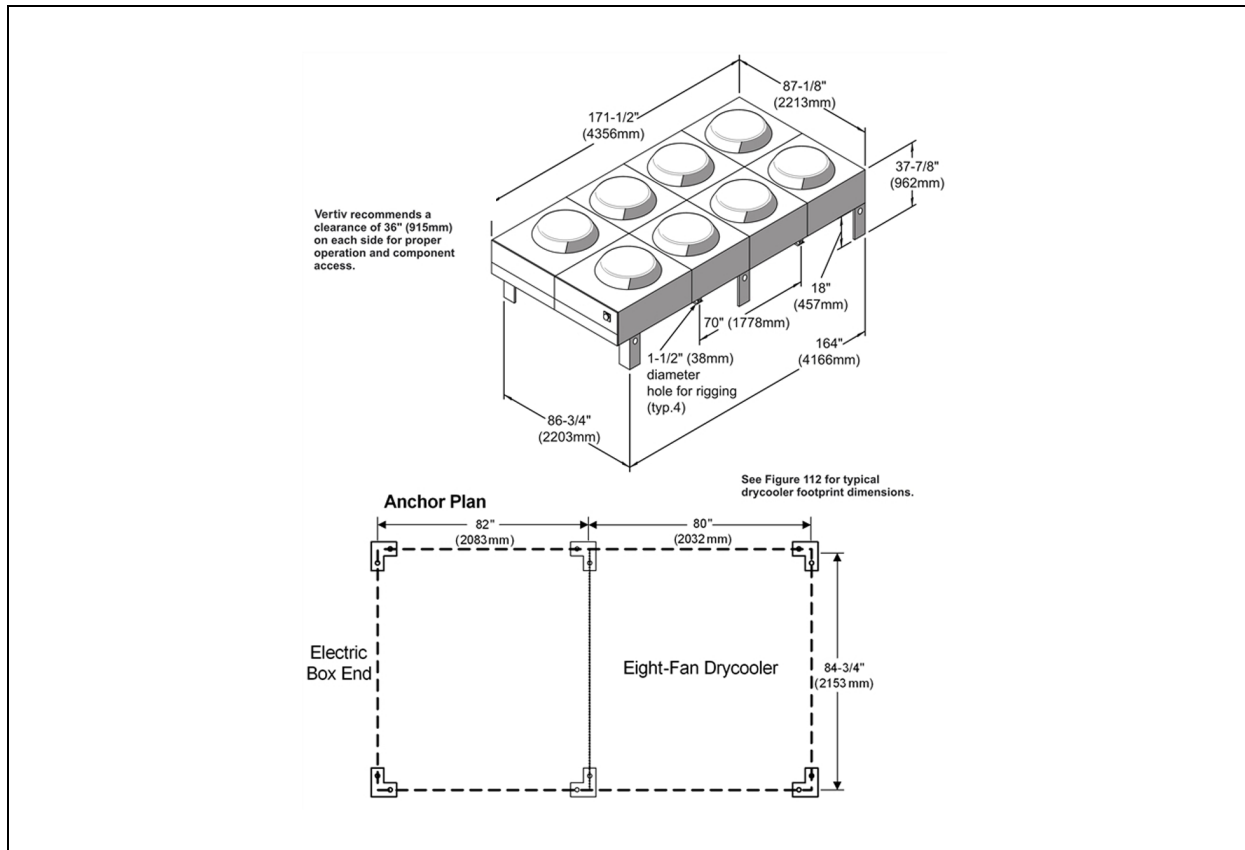



Figure 6.14 Typical drycooler footprint—dimensions

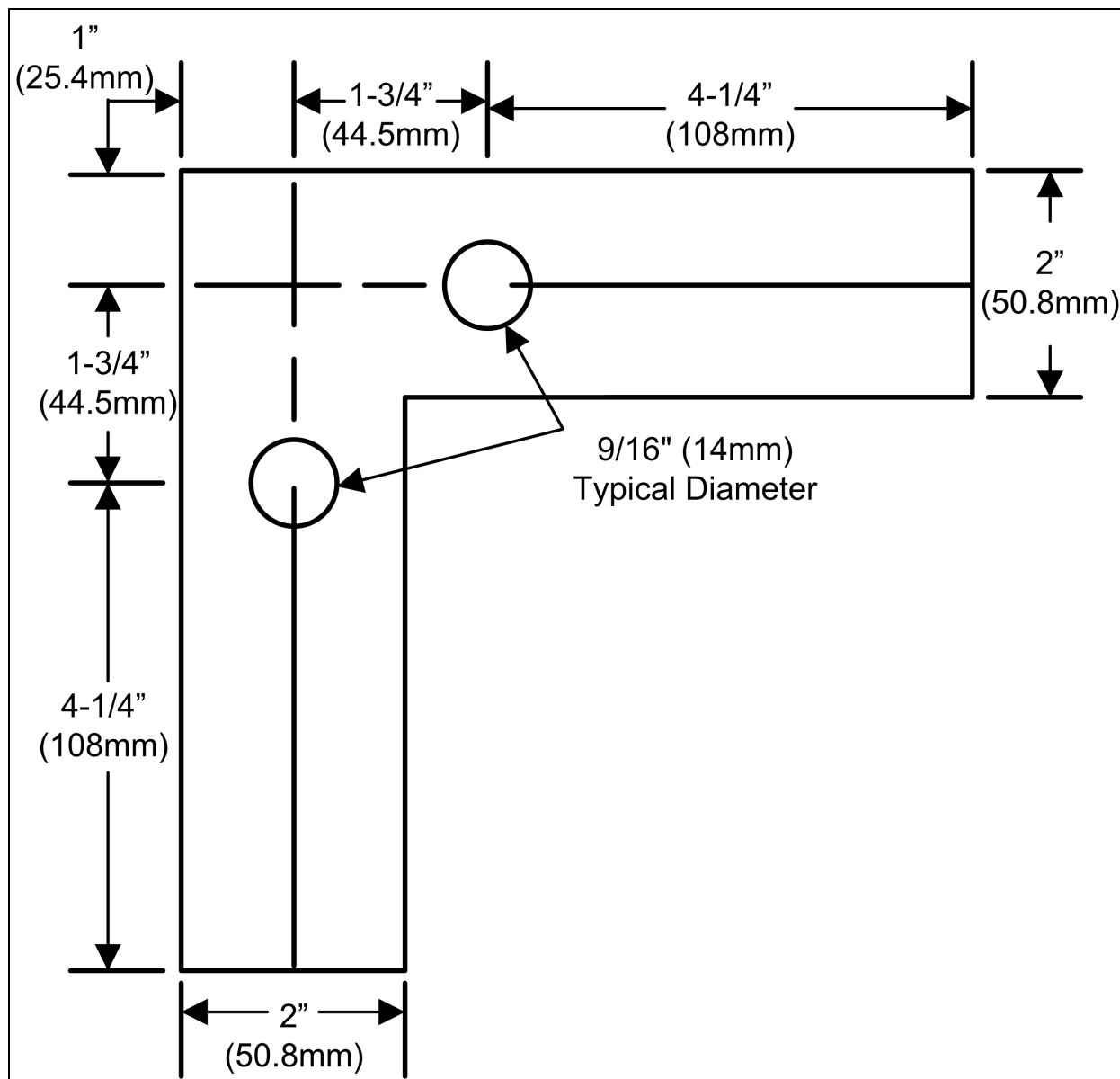
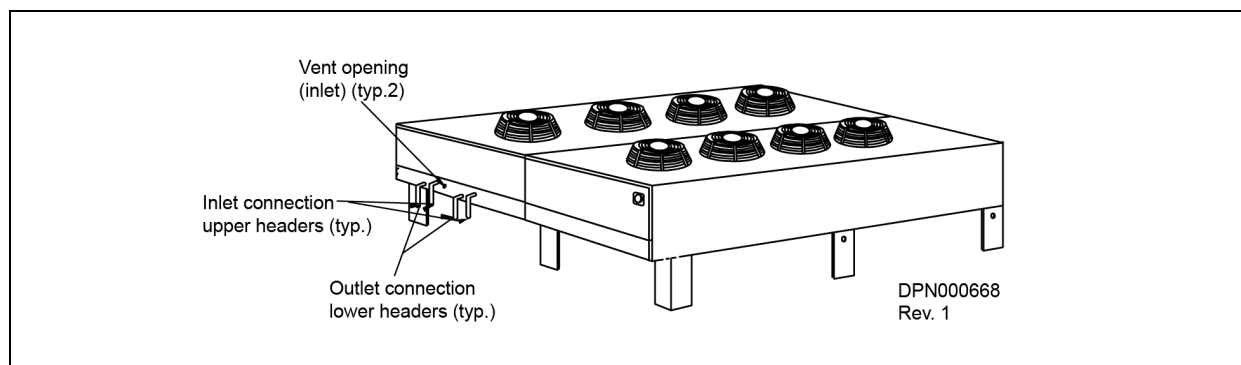

Figure 6.15 Piping connections for 8-fan drycoolers



**Table 6.14 Standard drycooler piping connection sizes and internal volume**

Drycooler Model #	No. of Internal Coil Circuits	No. of Fans	Internal Volume, gal. (L.)	No. of Inlets/Outlets	Inlet & Outlet Connection Size	
					OD Copper, in.	ID Sweat, in.
880	80*	8	44.0 (166.5)	4/4	—	2-1/8
940	96*	8	52.0 (196.8)	4/4	—	2-1/8

\* = Standard Circuiting

## 6.10 Mounting the Drycooler

The drycooler must be installed so that it is level within 1/2" (13mm) to ensure proper glycol flow, venting and drainage. For roof installation, mount the drycooler on suitable curbs or other supports; follow all local and national codes. Secure the legs to the mounting surface using a field-supplied 1/2" (13mm) diameter bolt in each of the two 9/16" (14mm) holes in each leg. See Figure 6.13 on page 138 for anchor dimensions.

## 6.11 Glycol Piping



**CAUTION: Risk of explosive discharge of high pressure gas and flying projectiles. Can cause building and/or piping damage and personal injury.**

**Units are shipped from the factory with a pressurized dry nitrogen holding charge. Carefully relieve the pressure before cutting into the piping system.**

### NOTICE

Risk of excessive coolant fluid pressure, improper piping material, and unsupported piping. Can cause piping rupture, coolant fluid leaks and building and/or equipment damage.

To avoid the possibility of burst pipes, the system installer must supply and install a relief valve in the system. Galvanized pipe must not be used in glycol systems. To help prevent piping failures, supply and return lines must be supported such that their weight does not bear on the piping of the unit or pumps.

### 6.11.1 Piping Guidelines

Piping between the drycooler, the pump and the indoor unit is required to complete the system and is to be provided and installed by the system installer. All fluid piping must comply with local codes. Properly sized pipes will help reduce pumping power and operating costs.

Pipe material choices are typically copper, plastic or steel/black iron. Consult glycol and pipe manufacturing literature for compatibility and sizing assistance. Galvanized piping should not be used. Any copper piping installed should be "L" or "K" refrigerant grade copper.

See Figure 6.12 on page 136 for a typical piping diagram, depicting multiple indoor units, multiple drycoolers and dual pumps. Single indoor unit/pump/drycooler systems are also possible.

Drycooler supply and return connections vary in size and number. Refer to Table 6.14 above. Vertiv recommends installing manual service shutoff valves at the supply and return connections of each drycooler and indoor cooling unit. The shutoff valves permit isolating equipment for routine maintenance and for repairs.

Multiple pump packages require a check valve at the discharge of each pump to prevent back-flow through the standby pump(s). To extend the service life of the drycooler and the system's pumps, install filters/strainers in the supply line to the pumps. These filters should have a 16-20 mesh screen and be a type that can be easily replaced or cleaned.

Installing hose bibs at the lowest point of the system will facilitate filling.

Keep piping runs as straight as possible; avoid unnecessary bends and minimize additional fittings.

Allow for pipe expansion from warm fluids. Piping should be isolated from the building with vibration-isolating supports. Use soft, flexible material to seal between pipes and wall openings to prevent pipe damage.

Consideration of the minimum glycol temperature to be supplied from the drycooler and the pipe routing will determine if the glycol supply and return lines should be insulated. Insulation will prevent condensation on the glycol lines in low ambient conditions.

Completed piping system should provide maximum leak-prevention. Welded or high-temperature soldered joints should be used where possible. Threaded pipe joints, if needed, can be made with tightly drawn Teflon™ tape.

Clean and prepare all pipe connections before joining. Be careful not to allow solder/joining debris to get inside the lines during the connection process.

### **6.11.2 Expansion Tanks, Fluid Relief Valves, Air Management and Other Devices**

An expansion tank must be provided for expansion and contraction of the fluid due to temperature change in this closed system. Vents are required at system high points to vent trapped air when filling the system. A fluid pressure relief valve is also a necessary piping component.

All systems must have an air management system to ensure proper component operation and system performance. There are several methods that can be used to manage the air within a closed loop hydronic system. Depending on the method chosen, the system may include one or more of the following ancillary components: tank-steel (expansion, compression, diaphragm or bladder), air separator and air vent.

Consult your local engineer to determine which method will be used and where these components must be installed.

Depending on the complexity of the system, various other devices may be specified—refer to site-specific drawings. Some of the devices that may be required are: pressure gauges, flow switches, automatic air separator, tempering valves, standby pumps and sensors for electrical controls.

#### **NOTICE**

Risk of frozen coolant fluid. Can cause piping rupture, coolant fluid leaks and building damage.

Immediately following the use of water for leak testing or system cleaning, charge the tested system with the proper percentage of glycol and water for your coldest design ambient. Complete system drain-down cannot be ensured and damage to the system could result from freezing of residual water.

## **6.12 Electrical Supply**

Line voltage electrical service is required for all models. Refer to equipment nameplate regarding wire size and circuit protection requirements. Electrical service must conform to national and local electrical codes. Refer to electrical schematic when making connections.

Each unit is shipped from the factory with all internal unit wiring completed.

 **WARNING! Risk of electric shock. Can cause injury or death.**

Disconnect all local and remote electrical power supplies before working within the electrical enclosure.

The line side of the disconnect remains energized when the disconnect is Off.

Use a voltmeter to verify that the electrical power is Off before performing any electrical and/or mechanical service and/or maintenance operations.

 **WARNING! Risk of high speed moving parts. Can cause injury or death.**

The fan(s) blades can start to rotate unexpectedly when the power is On. Disconnect all local and remote electrical power supplies before working within the fan compartment.

Use a voltmeter to verify that the electrical power is Off before performing any electrical and/or mechanical service and/or maintenance operations.

Each unit is shipped from the factory with all internal unit wiring completed. Refer to the electrical schematic supplied with the drycooler when making line voltage supply, low voltage indoor unit interlock and any low voltage alarm connections. All wiring must be done in accordance with all applicable local, state and national electrical codes.

For electrical characteristics, refer to Table 6.15 on the facing page.

### 6.12.1 Line Voltage Wiring

 **WARNING! Risk of electrical fire and short circuit. Can cause property damage, injury or death.**

Select and install the electrical supply wire and overcurrent protection device(s) according to the specifications on the unit nameplate(s), per the instructions in this manual and according to the applicable national, state and local code requirements. Use copper conductors only. Make sure all electrical connections are tight. Unit-specific wiring diagrams are provided on each unit.

Drycooler rated voltage should be verified with available power supply upon receipt of unit but before installation. Refer to the unit electrical schematic and serial tag for specific electrical requirements. All wiring must be done in accordance with all applicable local, state and national electrical codes.

Line voltage electrical service is required for all drycoolers at the location of the drycooler. If the drycooler contains pump controls, the pump package voltage must match the drycooler voltage. See the unit's serial tag for specific electrical requirements of the drycooler and any pump package. A unit disconnect is standard on drycoolers with internal pump controls and optional on all other drycoolers. Site disconnect (s) may also be required per local code to isolate the drycooler/pumps for maintenance. Route the supply power to the site disconnect switch and then to the drycooler. Route the conduit through the hole provided in the cabinet. Connect earth ground to lug provided near terminal board.

**Table 6.15 60Hz electrical values - Eight-fan drycoolers without pump controls, standard models**

	Voltage	Phase	FLA	WSA	OPD
880, 940	208/230	3	28.0	28.9	35
	460	3	13.6	14.0	20
	575	3	11.2	11.6	15

Values are calculated per UL 1995. OPD values may be adjusted higher than calculations to compensate for maximum anticipated application temperatures.

**Table 6.16 60Hz pump FLA values**

Pump hp	Input Power, Volts	
	208	460
10	30.8	14.0

Values based on NEC handbook values for 3-phase motors.

## 6.12.2 Low Voltage Control Wiring

### NOTICE

Risk of control malfunction. Can cause improper unit operation.

Make sure that all low voltage electrical wiring has been performed per the schematic diagram provided and that all low voltage wiring connections are tight.

A control interlock between the drycooler and the indoor cooling units is required. Field-supplied copper wire is required for connection between like-numbered Terminals 70 & 71 on both units for remote On/Off control of the drycooler, synchronized with the indoor unit. Wiring must be sized and selected for insulation class per NEC and other local codes. The recommended control circuit wire (24VAC) size is 16AWG for lengths up to 150ft. (45m). Contact the factory for assistance with longer wiring runs.

**Table 6.17 Minimum recommended control circuit wire size, AWG, 60 Hz models**

Control Wire Run, ft (m)	Drycooler Types With Pump Controls													
	DSF			DDF			DSO			DDO				
	Number of Fans							Number of Fans						
	1	1	1	2	3	4	6	8	1	2	3	4	6	8
0-25 (0-7.6)	16	16	16	16	16	16	16	16	16	16	16	16	16	16
26-50 (7.9-15.2)	16	16	16	16	16	16	16	14	16	14	14	14	14	14
51-75 (15.5-22.8)	16	16	16	16	16	16	14	14	14	14	14	12	14	14
76-100 (23.2-30.4)	16	16	16	16	16	16	12	12	12	12	12	12	12	12
101-125 (30.8-38.1)	16	14	16	16	14	14	12	12	12	10	10	10	10	10
126-150 (38.4-45.7)	16	14	16	14	14	14	10	12	10	10	10	10	10	10

**Table 6.17 Minimum recommended control circuit wire size, AWG, 60 Hz models (continued)**

Control Wire Run, ft (m)	Drycooler Types With Pump Controls														
	DSF	DDF	DSO						DDO						
	Number of Fans								Number of Fans						
	1	1	1	2	3	4	6	8	1	2	3	4	6	8	
Control Wire Run, ft (m)	Drycooler Types Without Pump Controls														
	(D)DNL		(D)DNT												
	Number of Fans														
	1-4	6 & 8	1	2	3	4	6	8							
0-25 (0-7.6)	16	16	16	16	16	16	16	16							
26-50 (7.9-15.2)	16	16	16	16	16	16	16	16							
51-75 (15.5-22.8)	16	16	16	16	16	16	16	14							
76-100 (23.2-30.4)	16	16	16	16	16	16	16	12							
101-125 (30.8-38.1)	16	16	16	16	16	16	14	12							
126-150 (38.4-45.7)	16	16	16	16	16	14	14	10							
Data based on 16 AWG min. wire size, 0.4 Amp per contactor, 1 to 1.5 Volt maximum drop & 104 °F (40 °C) average ambient temperature															

**Table 6.18 Minimum recommended control circuit wire size, mm2, 50Hz models**

Control Wire Run, m (ft)	Drycooler Types With Pump Controls														
	DSF	DDF	DSO						DDO						
	Number of Fans								Number of Fans						
	1	1	1	2	3	4	6	8	1	2	3	4	6	8	
0-7.6 (0-25)	1.0	1.0	1.0	1.0	1.0	1.0	1.0	1.5	1.0	1.5	1.5	1.5	1.5	1.5	
7.9-15.2 (26-50)	1.0	1.0	1.0	1.0	1.0	1.0	2.5	2.5	2.5	2.5	2.5	2.5	2.5	2.5	
15.5-22.8 (51-75)	1.0	1.5	1.0	1.5	1.5	1.5	4.0	4.0	4.0	4.0	4.0	4.0	4.0	4.0	
23.2-30.4 (76-100)	1.0	2.5	1.0	1.5	2.5	2.5	4.0	6.0	4.0	6.0	6.0	6.0	6.0	6.0	
30.8-38.1 (101-125)	1.5	2.5	1.5	2.5	2.5	2.5	6.0	6.0	6.0	6.0	6.0	6.0	6.0	6.0	
38.4-45.7 (126-150)	1.5	4.0	1.5	2.5	4.0	4.0	6.0	6.0	6.0	6.0	6.0	10.0	6.0	6.0	
Control Wire Run, m (ft)	Drycooler Types Without Pump Controls														
	(D)DNL		(D)DNT												
	Number of Fans														
	1-4	6 & 8	1	2	3	4	6	8							
0-7.6 (0-25)	1.0	1.0	1.0	1.0	1.0	1.0	1.0	1.0							

**Table 6.18 Minimum recommended control circuit wire size, mm<sup>2</sup>, 50Hz models (continued)**

Control Wire Run, m (ft)	Drycooler Types With Pump Controls													
	DSF	DDF	DSO						DDO					
	Number of Fans													
	1	1	1	2	3	4	6	8	1	2	3	4	6	8
7.9-15.2 (26-50)	1.0	1.0	1.0	1.0	1.0	1.0	1.0	2.5						
15.5-22.8 (51-75)	1.0	1.0	1.0	1.0	1.0	1.5	1.5	4.0						
23.2-30.4 (76-100)	1.0	1.0	1.0	1.0	1.0	1.5	2.5	4.0						
30.8-38.1 (101-125)	1.0	1.5	1.0	1.5	1.5	2.5	2.5	6.0						
38.4-45.7 (126-150)	1.0	1.5	1.0	1.5	1.5	2.5	4.0	6.0						

Table based on 1.0 mm<sup>2</sup> min. wire size, 0.5 Amp per contactor, 1 to 1.5 Volt maximum drop & 40 °C (104 °F) average ambient temperature

## 6.13 Filling Instructions

### 6.13.1 Preparing the System for Filling

It is important to remove any dirt, oil or metal filings that may contaminate the cooling system piping in order to prevent contamination of the fresh glycol solution and fouling of the drycooler piping. The system should be flushed thoroughly using a mild cleaning solution or high-quality water and then completely drained before charging with glycol. Cleaning new systems is just as important as cleaning old ones. New systems can be coated with oil or a protective film; dirt and scale are also common. Any residual contaminants could adversely affect the heat transfer stability and performance of your system. In many cases, in both old and new systems, special cleaners are needed to remove scale, rust and hydrocarbon foulants from pipes, manifolds and passages. Clean heat transfer surfaces are important in maintaining the integrity of the heating/cooling system. For more information on cleaners and degreasers, contact your sales representative. Follow the manufacturer's instructions when using these products.

Calculate the internal volume of the system as closely as possible. The drycooler volumes are shown in Table 6.14 on page 140. Use Table 6.20 on page 147 for field-installed piping volumes. Indoor unit volumes are found in their user manuals.

### 6.13.2 Glycol Solutions

**NOTE: Glycol solutions should be considered for the protection of the coil. When glycol solutions are not used, damage can occur either from freezing or from corrosion from water.**

When considering the use of any glycol products in a particular application, you should review the latest Material Safety Data Sheets and ensure that the use you intend can be accomplished safely. For Material Safety Data Sheets and other product safety information, contact the supplier nearest you. Before handling any other products mentioned in the text, you should obtain available product safety information and take necessary steps to ensure safety of use.

#### NOTICE

Risk of mishandled glycol products. Can cause environmental damage.

When mishandled, glycol products pose a threat to the environment. Before using any glycol products, review the latest Material Safety Data Sheets and ensure that you can use the product safely. Glycol manufacturers request that the customer read, understand and comply with the information on the product packaging and in the current Material Safety Data Sheets. Make this information available to anyone responsible for operation, maintenance and repair of the drycooler and related equipment.

No chemical should be used as or in a food, drug, medical device, or cosmetic, or in a product or process in which it may contact a food, drug, medical device, or cosmetic until the user has determined the suitability and legality of the use. Since government regulations and use conditions are subject to change, it is the user's responsibility to determine that this information is appropriate and suitable under current, applicable laws and regulations.

## NOTICE

Risk of using the wrong type of glycol. Can cause piping damage, coolant fluid leaks, and substantial building damage.

Automotive antifreeze is unacceptable and must NOT be used.

Typical inhibited formula ethylene glycol and propylene glycol manufacturers and suppliers are Union Carbide (Ucartherm) and Dow Chemical (Dowtherm SR-1, Dowfrost). These glycols are supplied with corrosion inhibitors and do not contain a silicone anti-leak formula. Commercial ethylene glycol and propylene glycol, when pure, are generally less corrosive to the common metals of construction than water itself. Aqueous solutions of these glycols, however, assume the corrosivity of the water from which they are prepared and may become increasingly corrosive with use when not properly inhibited.

There are two basic types of additives:

- Corrosion inhibitors and
- Environmental stabilizers

The corrosion inhibitors function by forming a surface barrier that protects the metals from attack. Environmental stabilizers, while not corrosion inhibitors in the strictest sense of the word, decrease corrosion by stabilizing or favorably altering the overall environment. An alkaline buffer, such as borax, is a simple example of an environmental stabilizer, since its prime purpose is to maintain an alkaline condition (pH above 7).

The percentage of glycol to water must be determined by using the lowest design outdoor temperature in which the system is operating. Table 6.19 below indicates the solution volume of inhibited glycol required to provide freeze protection at various ambient temperatures.

**Table 6.19**

Glycol concentrations for freeze protection by ambient temperatures

Coolant Type	Temperature, °F (°C)							
	20 (-7)	10 (-12)	0 (-18)	-10 (-23)	-20 (-29)	-30 (-34)	-40 (-40)	-50 (-46)
Propylene Glycol % by Volume	18 *	29*	36	42	46	50	54	57
Ethylene Glycol % by Volume	17 *	26*	35	41	46	50	55	59

Based on Dowfrost™ (PG) and Dowtherm™ SR-1 (EG) product literature.  
\* Inhibitor levels should be adjusted to properly protect the system if solution concentrations are less than 30%.



## NOTICE

Risk of corrosive dilution water. Can cause piping system damage, coolant fluid leaks and substantial building damage.

The quality of water used for dilution must be considered because water may contain corrosive elements that reduce the effectiveness of the inhibited formulation. Surface water that is classified as soft (low in chloride and sulfate ion content—less than 100 ppm each) should be used.

### 6.13.3 Filling the System

Installation of hose bibs at the lowest point of the system is recommended.

When filling a glycol system keep air to a minimum. Air in glycol turns to foam and is difficult and time-consuming to remove. (Anti-foam additives are available and may be considered.)

Open all operating systems to the loop. With the top vent(s) open, fill the system from the bottom of the loop. This will allow the glycol to push the air out of the top of the system, minimizing trapped air. Fill to approximately 80% of calculated capacity. Fill slowly from this point, checking fluid levels until full.

**NOTE: For glycol solution preparation and periodic testing, follow manufacturer’s recommendations. Do not mix products of different manufacturers.**

**Table 6.20 Volume in standard Type "L" copper piping**

Diameter (in.)		Volume	
Outside	Inside	gal/ft	l/m
1-3/8	1.265	0.065	
1-5/8	1.505	0.092	1.15
2-1/8	1.985	0.161	2.00
2-5/8	2.465	0.248	3.08
3-1/8	2.945	0.354	4.40
3-5/8	3.425	0.479	5.95
4-1/8	3.905	0.622	7.73

### 6.14 Outdoor Control Enclosure

The Liebert Outdoor Control Enclosure is designed to be used with a Liebert condenser or drycooler to control one or more pump and/or fan motors. The enclosure is rated NEMA 3R when installed as shown in Figure 6.16 on the next page.

Figure 6.16 Liebert Outdoor Control Enclosure installed



Figure 6.17 Flow rate, 10 hp, 3500 rpm pump package, Model # 9A31258G3 in aluminum enclosure

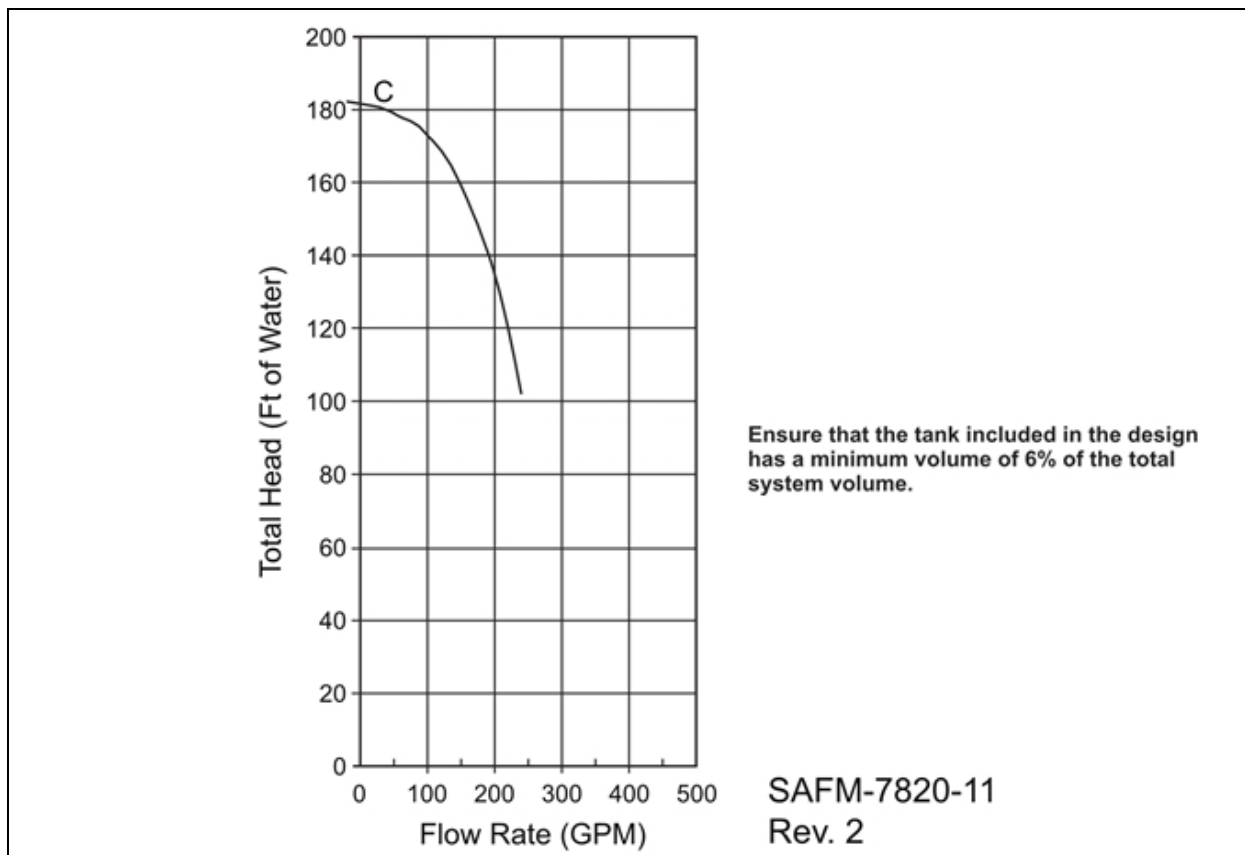

**Table 6.21 Liebert Outdoor Control Enclosure specifications**

Model	HP	Size	Impeller	Connections		FLA	Cabinet Size- in (mm)		
				Discharge	Suction		Length	Width	Height
D10ANTS1317	10	2 x 1.5 x 7	6.44	1.5 FPT	2.0 FPT	14	41.3	32.4	19.9
D10ANTS1317						30.8	(1049)	(822)	(506)

### 6.14.1 Electrical Connections



**WARNING!** Risk of electric shock. Can cause injury or death. Disconnect all local and remote power supplies before working within.

### 6.14.2 Hazardous Voltage Power Supply Wiring

Wire per national and local electrical codes.

Hazardous voltage electrical service is required at the location of the control enclosure. Use the knockouts provided at the bottom of the enclosure. This power supply does not have to be the same voltage as the Liebert indoor unit. This separate power source may be 110V, 208V, 230V, 460V or 575V, single-phase or three-phase, 60Hz; or it may be 200V, 230V, 380V or 415V, single-phase or three-phase, 50Hz as appropriate.

Install a field-supplied disconnect as required per local and national codes.

Figure 6.18 Dimensions and knockout sizes, 36-inch models

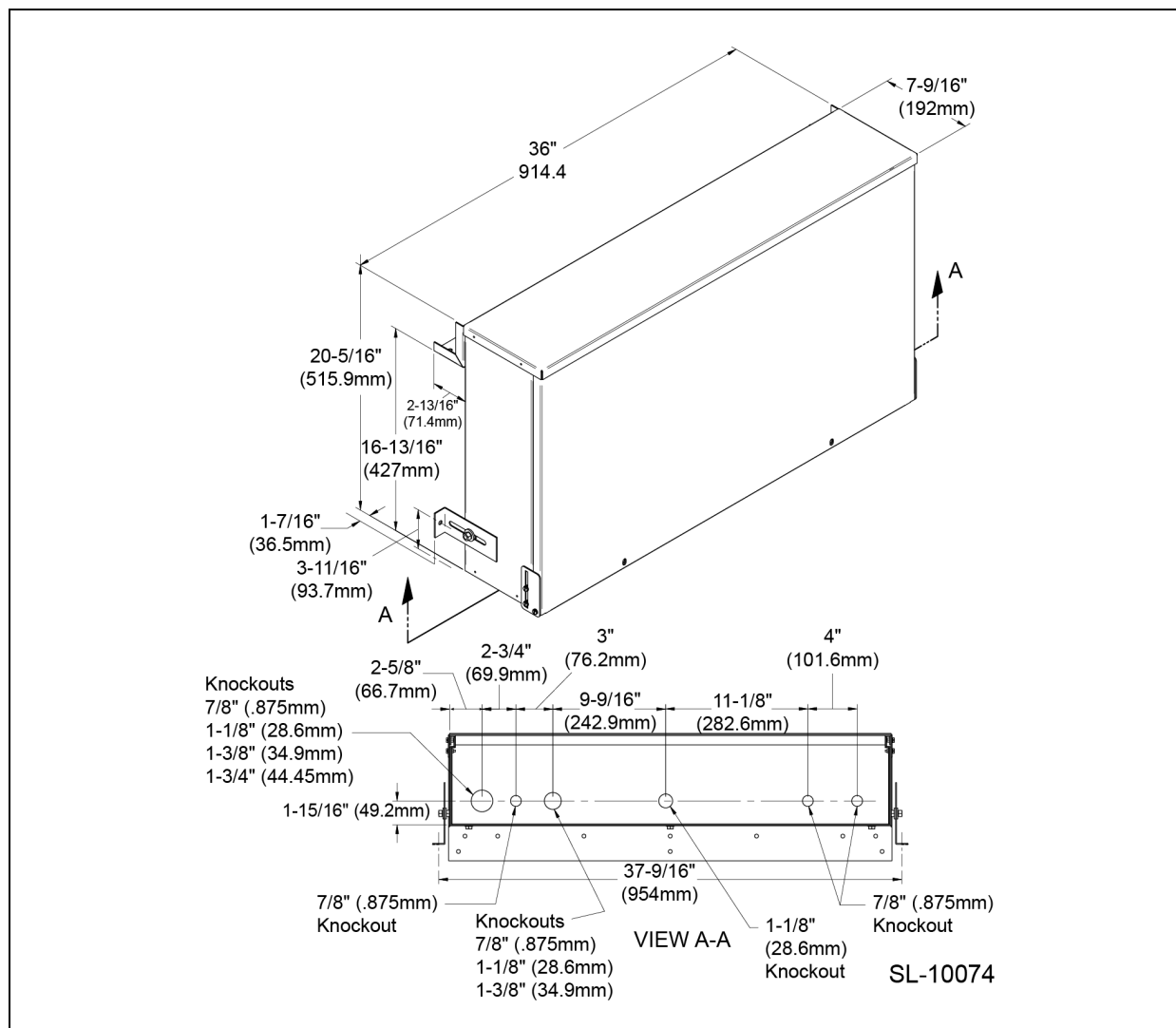

### 6.14.3 Extra-Low Voltage Control Wiring

Control interlock between the control enclosure and the indoor unit(s) or other source(s) is required. Multiple indoor units may be connected in parallel if the controlled pumps will feed them all.

- Extra-low voltage, non-safety control wiring must be a minimum of 16 GA. (1.665 mm<sup>2</sup>) for up to 75 feet (22.9m), or not to exceed 1V drop in the control line.
- Install extra-low voltage control wiring (24V) from Terminals 70 & 71 on the wire raceway in the compressor compartment of the indoor unit to Terminals 70 & 71 of the control enclosure.
- Extra-low voltage control wiring should also be installed between Terminals 24 and 50 from the control enclosure to the indoor cooling unit's common alarm or other alarm location for loss-of-flow indication.
- Install extra-low voltage control wiring between the auxiliary terminals on the control panel to Terminals 70 and 71 on the drycooler.
- The flow switch wiring should be connected to Terminals 77 and 74.

- Provide line voltage to power block(s) in control enclosure as shown in the electrical schematic.
- Install optional field-supplied disconnect if desired.
- Run three-phase line voltage from the control box to each individual pump motor.

#### 6.14.4 Dual Pump Package Flow Switch

Mount the flow switch in a section of coolant supply/return piping where there is a straight run of at least five (5) pipe diameters on each side of the flow switch.

- The switch should be mounted so the terminals or wire leads are easily accessible for wiring.
- Mount the flow switch in a standard 1" x 1" x 1" tee for one-inch pipe installation. Use a reducing tee for larger sizes of pipe to keep the flow switch near the pipe and to provide adequate paddle length in the flow stream.
- Screw the flow switch in position so the flat part of the paddle is at a right angle to the flow. The arrow on the side of the case must point in the direction of the flow.
- The flow switch must be mounted in a horizontal pipeline.

#### 6.14.5 Dual Pump Controls Sequence of Operation

On a call for cooling, the compressor contactor and/or the Econ-O-Coil relay in the Liebert unit is energized. The relay and contactor are in the Liebert indoor evaporator section. Each compressor contactor has a side switch wired in parallel with the Econ-O-Coil relay and is responsible for closure of the low-voltage pump-control circuit.

This low-voltage circuit has a series of contactors, relays, selector switch and a flow switch. This circuit controls the start of the pumps and provides contact closure to interlock the drycooler(s) control circuit. Once the circuit is closed, 24V is passed to the pumps control circuit and the auxiliary relays are energized, closing the drycooler(s) control circuit.

Pump P1 is factory-set to be the primary pump (Selector Switch 1-2). Voltage then passes through the normally closed contacts of the R2 relay (standby pump relay), through the current overloads and to the #1 pump contactor. At this point, the #1 pump and appropriate drycoolers are running.

When the pump establishes flow, it opens the system flow switch. The pump has approximately 10 seconds to establish full flow. If it does, the system will run in this state until the call for cooling is satisfied and the circuit drops out. If this pump cannot establish flow or if it has been running and fails, the flow switch will close and energize an adjustable relay, typically set for 10 seconds.

Once this relay times out, it energizes the R2 switch over relay. This relay will drop out the voltage to the #1 pump contactor and energize the #2 pump contactor. Along with the R2 relay the AL relay (alarm relay) will energize. This will provide a set of closed contacts for remote indication of the switch-over situation.

Once the problem with the lead pump is repaired, the controls must be reset. To reset the control box, turn Off the main power to the control box and then restore the main power to the control box. Pump P1 then becomes the primary pump again.

This page intentionally left blank.

## 7 LIEBERT ICOM

Figure 7.1 Liebert iCOM display—Liebert XDC and Liebert XDP

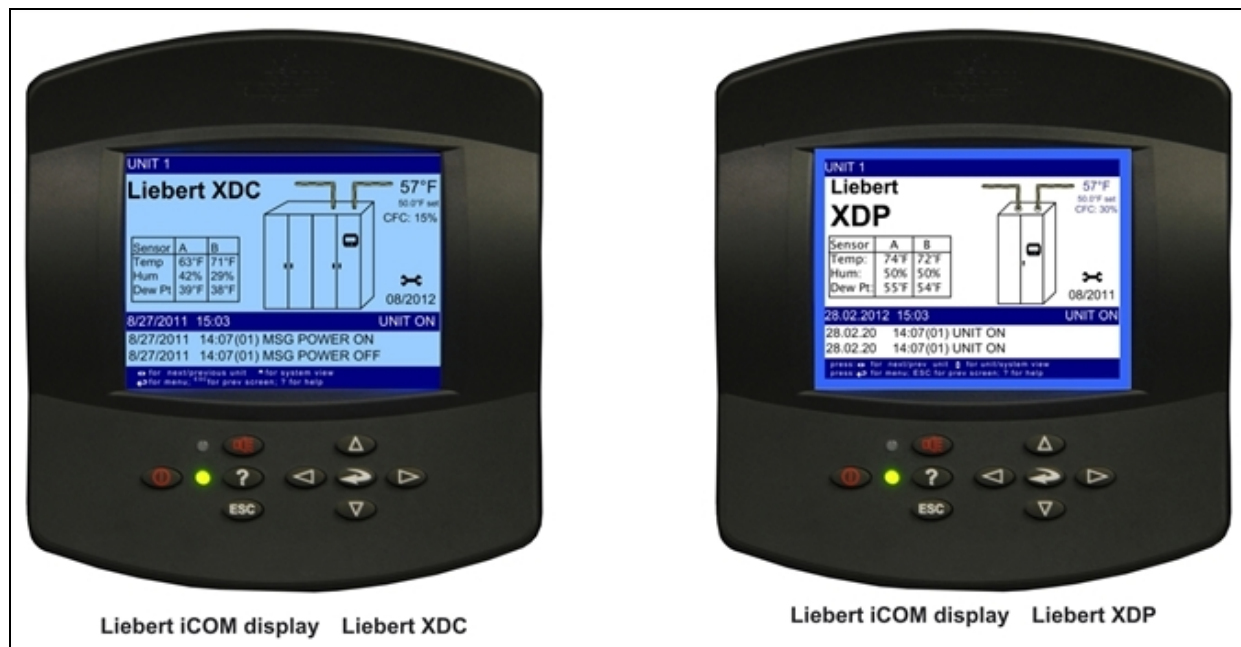

### 7.1 Liebert iCOM Display Layout

The Liebert iCOM displays icons and text for monitoring and controlling your Liebert cooling unit. Figures 105 and 106 shows the Liebert iCOM's home screen for the Liebert XDC and Liebert XDP.

Figure 7.2 Liebert iCOM default home screen for Liebert XDC

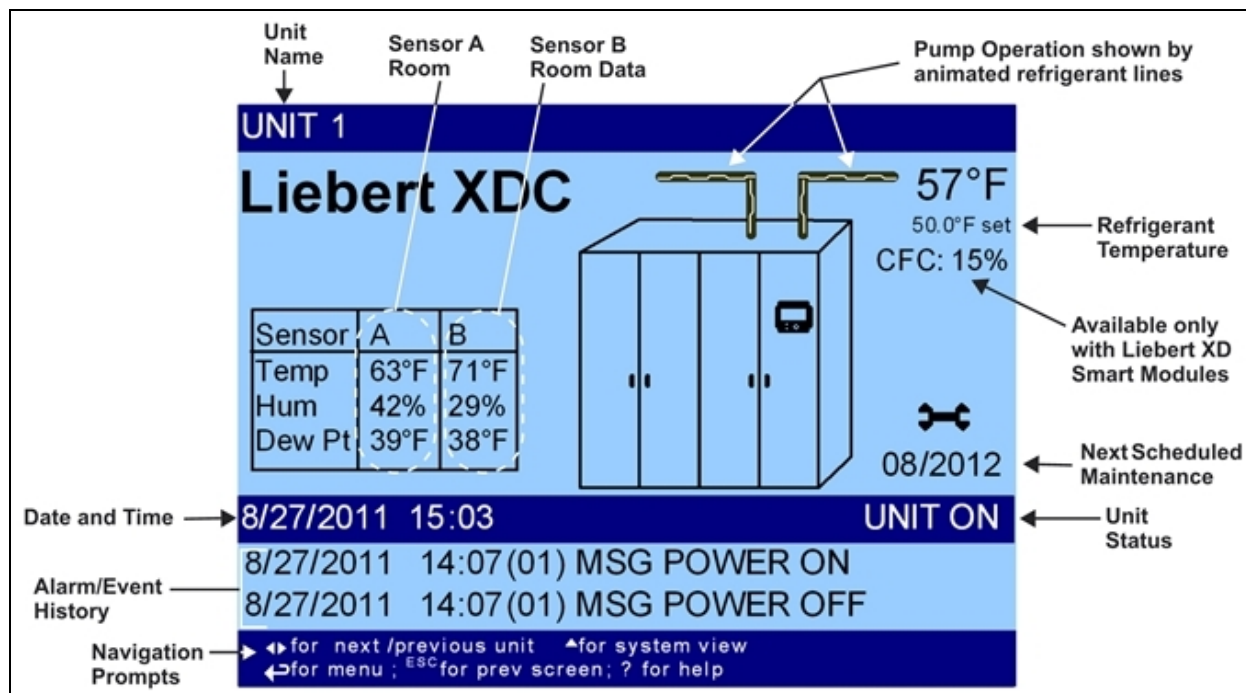
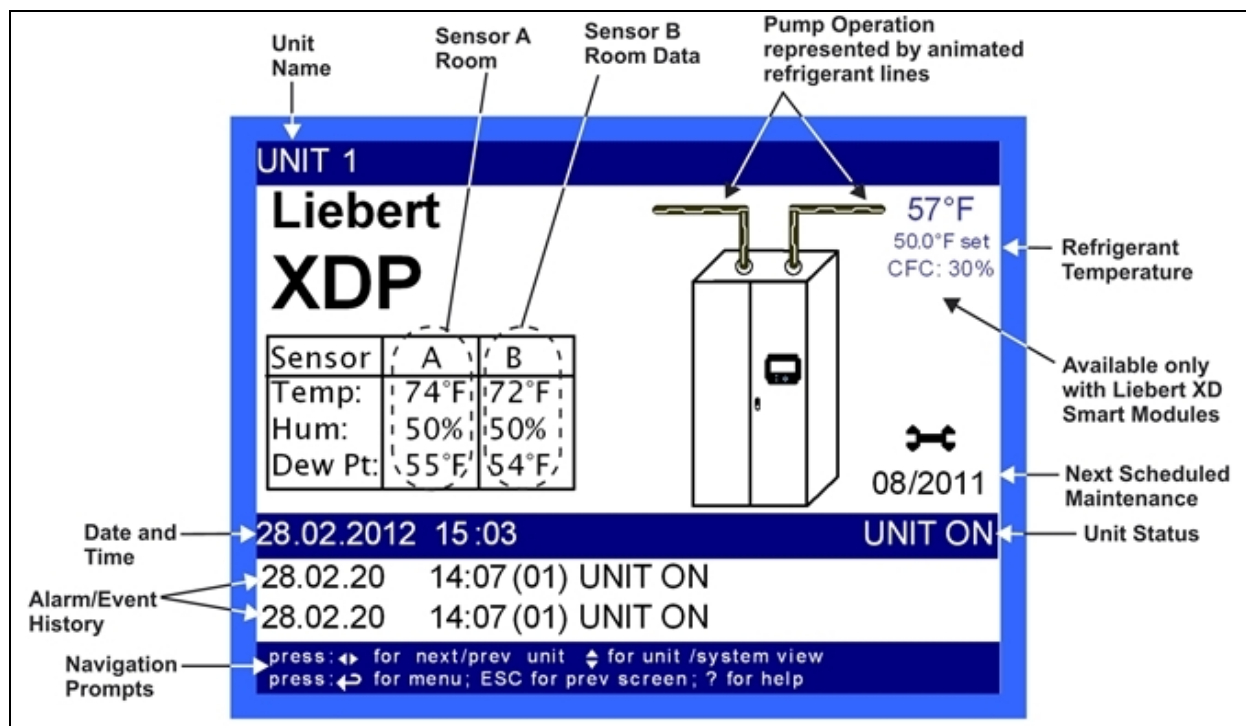

Figure 7.3 Liebert iCOM default home screen for Liebert XDP





## 7.2 Cooling Module Overview

The Liebert iCOM will display an overview of all connected cooling modules. It does not display a system view, which would include units other than the cooling modules (Figure 7.4 below). The Liebert iCOM will also display smart module parameters (Figure 7.5 on the next page).

Figure 7.4 Cooling module overview

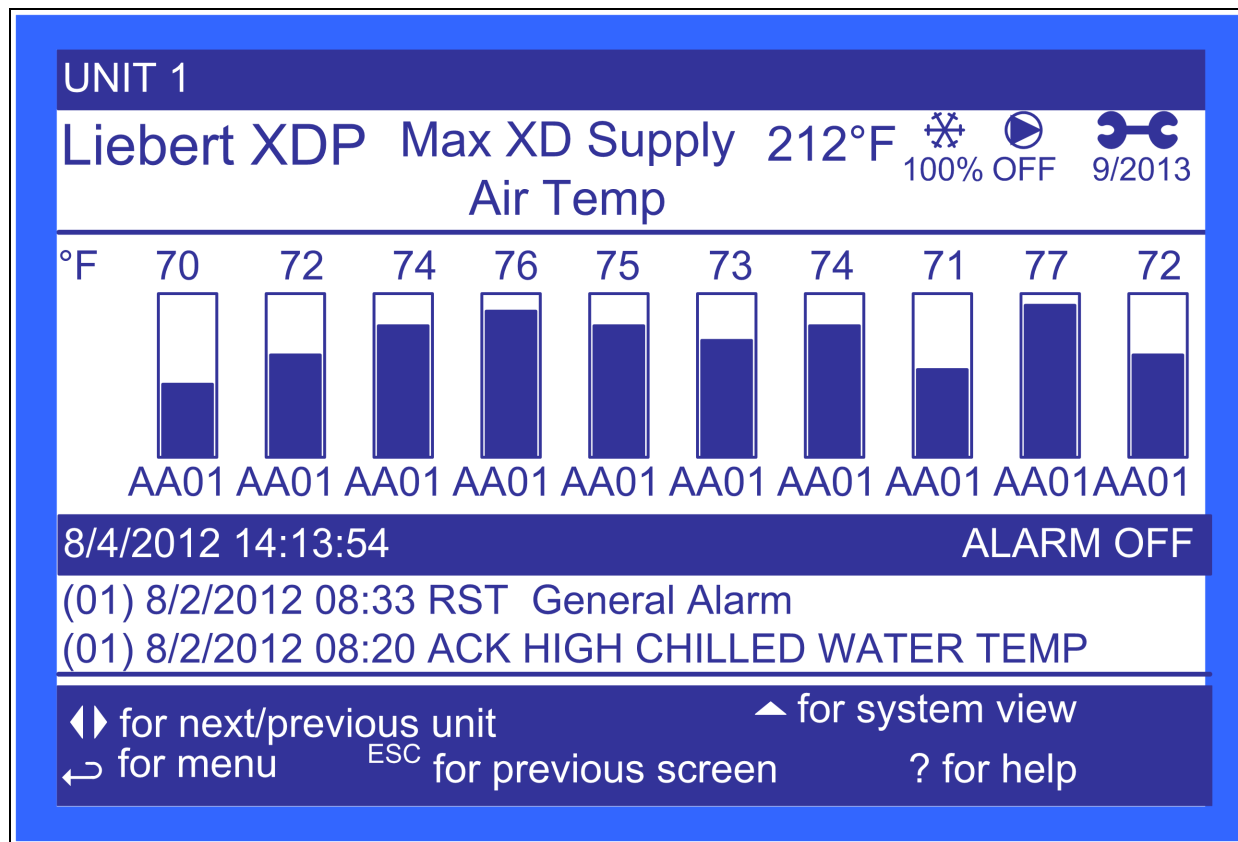
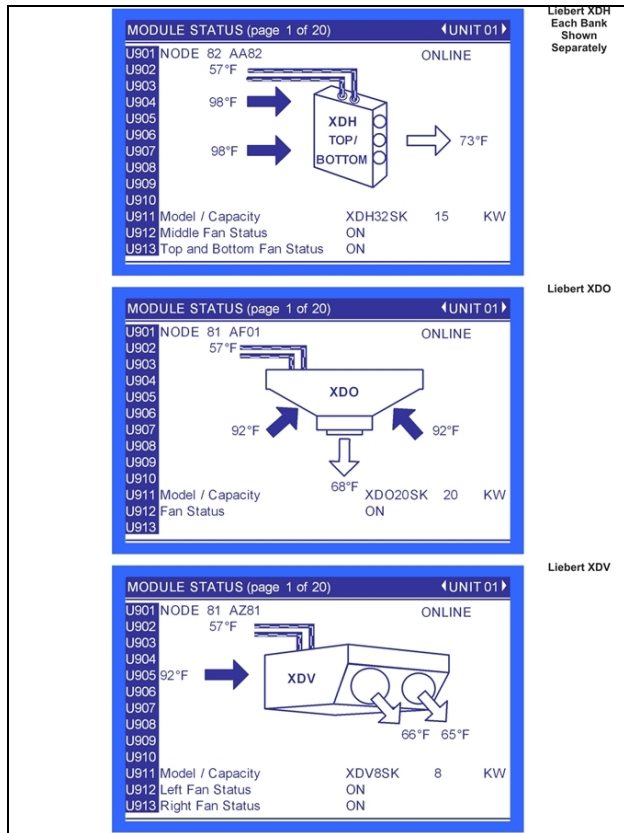

Figure 7.5 Smart module parameters—Liebert XDH, Liebert XDO, Liebert XDV



## 7.3 Graphical Data Record

The Graphical Data Record charts the average temperature from Sensors A and B, the average dew point from Sensors A and B, the supply refrigerant temperature and the supply refrigerant control point.











The temperature scales can be changed to expand or compress the data.

The time scale also can be altered to any of several selectable values.

### 7.3.1 Liebert iCOM User Menu Icons and Legend

User menus report general cooling unit operations and status. User Menu screens employ a coding that begins in “U” and is followed by parameters and information, such as settings.









**Table 7.1 Liebert iCOM User Menu icons**

<p>Setpoints</p> <p>View and change operational setpoints</p> <p>°C / °F % RH SET</p>	<p>Spare Parts List</p> <p>Contains spare parts available on site</p>	<p>Event Log</p>  <p>Lists last 400 events and alarms</p> <p>View Only</p>	<p>Graphic Data Record</p>  <p>Displays average temperature from Sensors A and B, the average dew point from Sensors A and B, the supply refrigerant temperature and the supply refrigerant control point graphs; Data is View Only;</p> <p>Display scale is adjustable</p>	<p>View Network</p>  <p>Shows status of all connected units; View Only</p>	<p>Set Alarms</p> <p>Allows user to change settings for alarms</p> 
<p>Sensor Data</p>  <p>Shows readings of sensors; View Only</p>	<p>Active Alarms</p>  <p>Lists all current alarms; View Only</p>	<p>Display Setup</p>  <p>Change settings for display: language and time</p>	<p>Total Run Hours</p>  <p>Records the run time of all components and allows setting of limits on run time; View Only</p>	<p>XDIO</p>  <p>Displays readings for the individual smart modules; View Only</p>	<p>Service Contacts</p>  <p>Contains key contact information for service</p>

### 7.3.2 Liebert iCOM Service Menu Icons and Legend

Service menus allow customized settings for site operations. Service Menu screens employ a coding that begins in “S” and is followed by parameters and information, such as settings.

**Table 7.2 Liebert iCOM Service Menu icons**

<p>Setpoint</p> <p>°C / °F % RH SET</p> <p>View and change operational setpoints</p>	<p><b>Unit Diary</b></p>  <p>Shows all program changes and maintenance performed,</p>	<p>Maintenance/Wellness Settings</p>  <p>Shows all maintenance records, calculates next maintenance date</p>	<p>Diagnostics/Service Mode</p>  <p>Enter Diagnostics/Service Mode for troubleshooting and repair</p>	<p>Set Alarms</p> <p>Change settings for alarms</p> 
<p>Sensor Calibration/Setup</p>  <p>Setup and calibrate sensors for site</p>	<p>Network</p>  <p>Setup or alter network setting.</p>	<p>Options Setup</p>  <p>Enter specific settings for various options</p>	<p><b>Smart Module</b></p> <p>Setup of alarms and events. Set temperature limits for supply and return sensors. Label smart modules, view firmware version.</p> 	<p>Service Contacts</p>  <p>Contains key contact information for service</p>

### 7.4 Liebert XDC Alarms Descriptions

**NOTE: Alarms must be acknowledged before they can be reset. To acknowledge or silence an alarm, press the ALARM key one time. This will silence the alarm; the red LED will remain illuminated until the alarm is reset.**

- **CALL SERVICE**—Activated when Customer Input 1 is configured for “Call Service” and 24VAC is applied to the input. This alarm is reset when the 24VAC is removed.
- **COMP 1A HIGH PRESSURE**—Activated when the control senses a high head pressure signal from Compressor 1A. This alarm will reset when the main power is cycled or the HP 1A Alarm Code variable in the Service Diagnostics menu is reset to 0.

- **COMP 1B HIGH PRESSURE**—Activated when the control senses a high head pressure signal from Compressor 1B. This alarm will reset when the main power is cycled or the HP 1B Alarm Code variable in the Service Diagnostics menu is reset to 0.
- **COMP 2A HIGH PRESSURE**—Activated when the control senses a high head pressure signal from Compressor 2A. This alarm will reset when the control power is cycled or the HP 2A Alarm Code variable in the Service Diagnostics menu is reset to 0.
- **COMP 2B HIGH PRESSURE**—Activated when the control senses a high head pressure signal from Compressor 2B by the control. This alarm will reset when the main power is cycled or the HP 2B Alarm Code variable in the Service Diagnostics menu is reset to 0.
- **COMP 1A SHORT CYCLE**—Activated when Compressor 1A turns On, Off, then back On, 10 times within 1 hour. The alarm will reset itself when the control turns Compressor 1A On, then Off fewer than 10 times within 1 hour of operating time for 1.5 hours.
- **COMP 1B SHORT CYCLE**—Activated when Compressor 1B turns On, Off, then back On, 10 times within 1 hour. The alarm will reset itself when the control turns Compressor 1B On, then Off fewer than 10 times within 1 hour of operating time for 1.5 hours.
- **COMP 2A SHORT CYCLE**—Activated when Compressor 2A turns On, Off, then back On, five times within 10 minutes or 10 times within 1 hour. The alarm will reset itself when the control turns Compressor 2A On, then Off fewer than 10 times within 1 hour of operating time for 1.5 hours.
- **COMP 2B SHORT CYCLE**—Activated when Compressor 2B turns On, Off, then back On, five times within 10 minutes or 10 times within 1 hour. The alarm will reset itself when the control turns Compressor 2B On, then Off fewer than 10 times within 1 hour of operating time for 1.5 hours.
- **COMPRESSOR(S) LOCKOUT**—Activated when Customer Input 1 is configured for “Comp Lock PD” and 24VAC is applied to the input. This alarm is reset when the 24VAC is removed.
- **CONDENSATION DETECTED (optional)**—Activated when water is detected at a cooling module. A 24VAC signal is applied to the condensation input on the control board using a twisted pair of wires or the alarm is sent via CANbus communication. When this alarm is active, the control will raise its refrigerant control point by 4°F (2.2°C). This alarm will reset when the alarms is acknowledged and the signal stops being sent from CANbus or condensation input. The alarm can also be reset by cycling the power. The main power must be cycled to remove the 4°F (2.2°C) offset.
- **CUSTOMER INPUT 1**—Activated when a 24VAC signal is applied to the customer alarm input on the control board. This alarm will reset when the 24VAC signal stops being sent from the customer alarm input. WATER UNDER FLOOR, SMOKE DETECTED, CALL SERVICE and COMP LOCK PD are possible designations for this alarm; they are set with the Unit Code.
- **FAN FAILURE (optional)**—Activated when a 24VAC signal is applied to the fan failure input on the control board using a twisted pair of wires or the alarm is sent via CANbus communication. This alarm will reset when the alarms is acknowledged and the signal stops being sent from CANbus or fan failure input. The alarm can also be reset by cycling the power.
- **HIGH DEW POINT**—Activates when the calculated dew point at either Sensor A or B exceeds the user-specified alarm setpoint. The alarm will reset when the calculated room dew point from both Sensor A and Sensor B is 2°F (1.1°C) below the setpoint and the alarm has been acknowledged.

- **HIGH REFRIGERANT TEMP**—Activated when the refrigerant temperature sensor reads the refrigerant temperature above the user-specified alarm setpoint. This alarm will reset when the reading from the refrigerant temperature sensor drops 2°F (1.1°C) below the user-specified setpoint and the alarm has been acknowledged.
- **HIGH TEMP SENSOR A**—Activated when the reading from Sensor A is above the user-specified alarm setpoint. The alarm will reset when the reading from Sensor A drops 2°F (1.1°C) below the setpoint and the alarm has been acknowledged.
- **HIGH TEMP SENSOR B**—Activated when the reading from Sensor B is above the user-specified alarm setpoint. The alarm will reset when the reading from Sensor B drops 2°F (1.1°C) below the setpoint and the alarm has been acknowledged.
- **LOSS OF FLOW PUMP 1**—Activated when Pump 1 is commanded to run and the differential pressure switch does not sense differential pressure (set at 6 psi; 41kPa; 0.41 bars). After attempting to start Pump 1 three times, the Liebert XDC will automatically switch to the other pump to establish flow. This alarm will reset when flow has been established on Pump 1 and the alarm has been acknowledged.
- **LOSS OF FLOW PUMP 2**—Activated when Pump 2 is commanded to run and the differential pressure switch does not sense differential pressure (set at 6 psi; 41kPa; 0.41 bars). After attempting to start Pump 2 three times, the Liebert XDC will automatically switch to the other pump to establish flow. This alarm will reset when flow has been established on Pump 2 and the alarm has been acknowledged.
- **LOW MEMORY**—Activated when the control board is low in memory resources. This alarm rests automatically as soon as memory consumption falls below the threshold.
- **LOW REFRIGERANT TEMP**—Activated when the supply refrigerant temperature sensor temperature reading drops below the higher of the two calculated dew points, assuming that neither Sensor A or Sensor B has a sensor failure alarm. This alarm will reset when the refrigerant temperature sensor reads the refrigerant temperature above both of the two calculated dew points and the alarm has been acknowledged. This alarm can lock the unit Off. If this occurs, the main power must be cycled, or the Low Refrig Temp Alarm Code in the Service Diagnostics menu must be reset to 0.
- **LOW TEMP SENSOR A**—Activates when the reading from Sensor A drops below the user-specified alarm setpoint. The alarm will reset when the reading from Sensor A rises 2°F (1.1°C) above the setpoint and the alarm has been acknowledged.
- **LOW TEMP SENSOR B**—Activates when the reading from Sensor B drops below the user-specified alarm setpoint. The alarm will reset when the reading from Sensor B rises 2°F (1.1°C) above the setpoint and the alarm has been acknowledged.
- **NODEX CONDENSATION DETEC**—Activated when condensation is detected on a smart module at CAN node ID X, where X is a value ranging from 81 to 100. This alarm resets when condensate is no longer detected. The main power must be cycled off to remove the 4°F (2.2°C) offset value.
- **NODEX FAN FAILURE**—Activated when a fan failure occurs on a smart module at CAN node ID X, where X is a value ranging from 81 to 100. The alarm will rest when the fan returns to normal operation.
- **NODEX LOCAL SHUT DOWN**—Activated when a smart module at CAN node ID X, where X is a value ranging from 81 to 100, has been shut down by an external signal. This alarm will reset when the remote shutdown input is deactivated.

- **NODEX RETURNAIR TEMPLIMIT**—Activated when the return air temperature (entering air temperature to the module) exceeds the user-specified return air temperature range on a smart module at CAN node ID X, where X is a value ranging from 81 to 100. This alarm will reset when the return air temperature return to with the user-specified range.
- **NODEX SENSOR FAILURE**—Activated when a smart module at CAN node ID X, where X is a value ranging from 81 to 100, stops receiving a signal from one or more of its supply air, return air, or refrigerant temperature sensors. This alarm will reset when signals are detected from the module's sensors.
- **NODEX SUPPLYAIR TEMPLIMIT**—Activated when the supply air temperature (temperature of the air leaving the module) exceeds the user-specified supply air temperature range on a smart module at CAN node ID X, where X is a value ranging from 81 to 100. This alarm will reset when the return air temperature return to with the user-specified range.
- **PUMP SHORT CYCLE**—Activated when the Liebert XDC is trying to establish flow (differential pressure) and is unable to do so. The Liebert XDC will attempt three times to establish flow on a pump before trying the other pump. The control will keep cycling three times on one pump, then three times on the other pump until it is able to establish flow (differential pressure). If this cycling occurs for 30 minutes and the Liebert XDC still does not establish flow, a PUMP SHORT CYCLE alarm will be present. This alarm will shut down the Liebert XDC. To reset this alarm, the main power must be cycled.
- **RAM/BATTERY FAIL**—Activated when the RAM backup battery or the RAM itself has failed. This requires a hardware replacement.
- **SENSOR A FAILURE**—Activated when the controls no longer senses a signal from Sensor A. This alarm will reset when the signal is returned and the alarms has been acknowledged.
- **SENSOR B FAILURE**— Activated when the controls no longer senses a signal from Sensor B. This alarm will reset when the signal is returned and the alarm has been acknowledged.
- **SMOKE DETECTED**—Activated when the Customer Input 1 is configured for “Smoke” and 24VAC is applied to the input. This alarm is reset when the 24VAC is removed.

**NOTE: This is not a room smoke detector and is not intended to replace external smoke detectors.**

- **SUPPLY REFRIGERANT SENSOR FAILURE**—Activated when the control no longer senses a signal from the supply refrigerant sensor. This alarm will reset when the signal is returned.
- **TANDEM BANK 1 LP**—Activated when the low-pressure switch for Tandem Compressor Bank 1 doesn't send the proper signal during normal operation, or during pump-down. This alarm will reset when the main power is cycled or the Tandem Bank 1 LP Code variable in the Service Diagnostics menu is reset to 0.
- **TANDEM BANK 2 LP**—Activated when the low-pressure switch for Tandem Compressor Bank 2 doesn't send the proper signal during normal operation, or during pump-down. This alarm will reset when the main power is cycled or the Tandem Bank 2 LP Code variable in the Service Diagnostics menu is reset to 0.
- **TANDEM BANK 1 PD**—Activated when Tandem Compressor Bank 1 suction pressure cannot be pumped down below the threshold during compressor shutdown. This alarm will reset when the main power is cycled or the Tandem Bank 1 PD Alarm Code variable in the Service Diagnostics menu is reset to 0.
- **TANDEM BANK 2 PD**—Activated when Tandem Compressor Bank 2 suction pressure cannot be pumped down below the threshold during compressor shutdown. This alarm will reset when the main power is cycled or the Tandem Bank 2 PD Alarm Code variable in the Service Diagnostics menu is reset to 0.

- **UNIT CODE MISSING**—Activated when a valid unit code has not been entered and saved. To reset, enter valid unit code, save and execute.
- **WATER UNDER FLOOR**—Activated when Customer Input 1 is configured for “Water Alarm” and 24VAC is applied to the input. This alarm is reset when the 24VAC is removed.

## 7.5 Warning Descriptions

- **COMPRESSOR 1A HRS EXCEED**—Activated when the Compressor 1A Actual Hours exceeds the user-specified limit. To reset, Actual Hours must be reset to 0.
- **COMPRESSOR 1B HRS EXCEED**—Activated when the Compressor 1B Actual Hours exceeds the user-specified limit. To reset, Actual Hours must be reset to 0.
- **COMPRESSOR 2A HRS EXCEED**—Activated when the Compressor 2A Actual Hours exceeds the user-specified limit. To reset, Actual Hours must be reset to 0.
- **COMPRESSOR 2B HRS EXCEED**—Activated when the Compressor 2B Actual Hours exceeds the user-specified limit. To reset, Actual Hours must be reset to 0.
- **PUMP 1 HRS EXCEED**—Activated when the Pump 1 Actual Hours exceeds the user-specified limit. To reset, Actual Hours must be reset to 0.
- **PUMP 2 HRS EXCEED**—Activated when the Pump 2 Actual Hours exceeds the user-specified limit. To reset, Actual Hours must be reset to 0.
- **LOSS OF POWER**—Activated when the unit is On and operational and 24VAC power to the control is lost. This alarm will be emitted when power is restored to the control. The Liebert XDC will restart at a user-defined time delay after power is restored. Once activated, the alarm will remain activated for 30 minutes.

## 7.6 Liebert XDP Alarms

**NOTE: Alarms must be acknowledged before they can be reset. To acknowledge or silence an alarm, press the ALARM key one time. This will silence the alarm; the red LED will remain illuminated until the alarm is reset.**

**CALL SERVICE**—Activated when Customer Input 1 is configured for “Call Service” and 24VAC is applied to the input. This alarm is reset when the 24VAC is removed.

**CONDENSATION DETECTED (optional)**—Activated when water is detected at a cooling module. A 24VAC signal is applied to the condensation input on the control board using a pair of twisted wires or the alarm is sent via CANbus communication. When this alarm is active, the control will raise its refrigerant control point by 4°F (2.2°C). This alarm will reset when the alarm is acknowledged and the signal stops being sent from CANbus or condensation input. The alarm can also be reset by cycling the power. The main power must be cycled to remove the 4°F (2.2°C) offset.

**CONTROL VALVE FAILURE**—Activated when the chilled water control valve has been commanded to open or close by the control and no change is detected by the valve position signal. The alarm is reset when the main power is cycled.

**CUSTOMER INPUT 1**—Activated when a 24VAC signal is applied to the customer alarm input on the control board. This alarm will reset when the 24VAC signal stops being sent from the customer alarm input. WATER UNDER FLOOR, SMOKE DETECTED, CALL SERVICE, and COMP LOCK PD are possible designations for this alarm; they are set with the Unit Code.

**FAN FAILURE (optional)**—Activated when a 24VAC signal is applied to the fan failure input on the control board using a twisted pair of wires or the alarm is sent via CANbus communication. This alarm will reset when the alarm is acknowledged and the signal stops being sent from CANbus or fan failure input. The alarm can also be reset by cycling the power.

**HIGH CW TEMP**—Activated when the Supply CW sensor reads the chilled water temperature above the user-specified alarm setpoint. This alarm will reset when the reading from the refrigerant temperature sensor drops 5°F (2.8°C) below the user-specified setpoint and the alarm has been acknowledged.

**HIGH DEW POINT**—Activates when the calculated dew point at either Sensor A or B exceeds the user-specified alarm setpoint. The alarm will reset when the calculated room dew point from both Sensor A and Sensor B is 2°F (1.1°C) below the setpoint and the alarm has been acknowledged.

**HIGH REFRIGERANT TEMP**—Activated when the refrigerant temperature sensor reads the refrigerant temperature above the user-specified alarm setpoint. This alarm will reset when the reading from the refrigerant temperature sensor drops 2°F (1.1°C) below the user-specified setpoint and the alarm has been acknowledged.

**HIGH TEMP SENSOR A**—Activated when the reading from Sensor A is above the user-specified alarm setpoint. The alarm will reset when the reading from Sensor A drops 2°F (1.1°C) below the setpoint and the alarm has been acknowledged.

**HIGH TEMP SENSOR B**—Activated when the reading from Sensor A is above the user-specified alarm setpoint. The alarm will reset when the reading from Sensor A drops 2°F (1.1°C) below the setpoint and the alarm has been acknowledged.

**LOSS OF FLOW PUMP 1**—Activated when Pump 1 is commanded to run and the differential pressure switch does not sense differential pressure (set at 6 psi; 41kPa; 0.41 bars). After attempting to start Pump 1 three times, the Liebert XDP will automatically switch to the other pump to establish flow. This alarm will reset when flow has been established on Pump 1 and the alarm has been acknowledged.

**LOSS OF FLOW PUMP 2**—Activated when Pump 2 is commanded to run and the differential pressure switch does not sense differential pressure (set at 6 psi; 41kPa; 0.41 bars). After attempting to start Pump 2 three times, the Liebert XDP will automatically switch to the other pump to establish flow. This alarm will reset when flow has been established on Pump 2 and the alarm has been acknowledged.

**LOW MEMORY**—Activated when the control board is low in memory resources. This alarm rests automatically as soon as memory consumption falls below the threshold.

**LOW REFRIGERANT TEMP**—Activated when the supply refrigerant temperature sensor temperature reading drops below the higher of the two calculated dew points, assuming that neither Sensor A or Sensor B has a sensor failure alarm. This alarm will reset when the refrigerant temperature sensor reads the refrigerant temperature above both of the two calculated dew points and the alarm has been acknowledged. This alarm can lock the unit Off. If this occurs, the main power must be cycled, or the Low Refrig Temp Alarm Code in the Service Diagnostics menu must be reset to 0.

**LOW TEMP SENSOR A**—Activated when the reading from Sensor A drops below the user-specified alarm setpoint. The alarm will reset when the reading from Sensor A rises 2°F (1.1°C) above the setpoint and the alarm has been acknowledged.

**LOW TEMP SENSOR B**—Activated when the reading from Sensor B drops below the user-specified alarm setpoint. The alarm will reset when the reading from Sensor B rises 2°F (1.1°C) above the setpoint and the alarm has been acknowledged.

**NODEX CONDENSATION DETEC**—Activated when condensation is detected on a smart module at CAN node ID X, where X is a value ranging from 81 to 100. This alarm resets when condensate is no longer detected. The main power must be cycled off to remove the 4°F (2.2°C) offset value.

**NODEX FAN FAILURE**—Activated when a fan failure occurs on a smart module at CAN node ID X, where X is a value ranging from 81 to 100. The alarm will rest when the fan returns to normal operation.



**NODEX LOCAL SHUT DOWN**—Activated when a smart module at CAN node ID X, where X is a value ranging from 81 to 100, has been shut down by an external signal. This alarm will reset when the remote shutdown input is deactivated.

**NODEX RETURN AIR TEMPLIMIT**—Activated when the return air temperature (entering air temperature to the module) exceeds the user-specified return air temperature range on a smart module at CAN node ID X, where X is a value ranging from 81 to 100. This alarm will reset when the return air temperature returns to within the user-specified range.

**NODEX SENSOR FAILURE**—Activated when a smart module at CAN node ID X, where X is a value ranging from 81 to 100, stops receiving a signal from one or more of its supply air, return air, or refrigerant temperature sensors. This alarm will reset when signals are detected from the module's sensors.

**NODEX SUPPLY AIR TEMPLIMIT**—Activated when the supply air temperature (temperature of the air leaving the module) exceeds the user-specified supply air temperature range on a smart module at CAN node ID X, where X is a value ranging from 81 to 100. This alarm will reset when the return air temperature returns to within the user-specified range.

**PUMP SHORT CYCLE**—Activated when the Liebert XDP is trying to establish flow (differential pressure) and is unable to do so. The Liebert XDP will attempt three times to establish flow on a pump before trying the other pump. The control will keep cycling three times on one pump, then three times on the other pump until it is able to establish flow (differential pressure). If this cycling occurs for 30 minutes and the Liebert XDP still does not establish flow, a PUMP SHORT CYCLE alarm will be present. This alarm will shut down the Liebert XDP. To reset this alarm, the main power must be cycled.

**RAM/BATTERY FAIL**—Activated when the RAM backup battery or the RAM itself has failed. This requires a hardware replacement.

**SENSOR A FAILURE**—Activated when the controls no longer sense a signal from Sensor A. This alarm will reset when the signal is returned and the alarm has been acknowledged.

**SENSOR B FAILURE**—Activated when the controls no longer sense a signal from Sensor B. This alarm will reset when the signal is returned and the alarm has been acknowledged.

**SMOKE DETECTED**—Activated when the Customer Input 1 is configured for “Smoke” and 24VAC is applied to the input. This alarm is reset when the 24VAC is removed.

**NOTE: This is not a room smoke detector and is not intended to replace external smoke detectors.**

**SUPPLY CW SENSOR FAILURE**—Activated when the control no longer senses a signal from the Supply CW sensor. This alarm will reset when the signal is returned.

**SUPPLY REFRIGERANT SENSOR FAILURE**—Activated when the control no longer senses a signal from the supply refrigerant sensor. This alarm will reset when the signal is returned.

**UNIT CODE MISSING**—Activated when a valid unit code has not been entered and saved. To reset, enter valid unit code, save and execute.

**WATER UNDER FLOOR**—Activated when Customer Input 1 is configured for “Water Alarm” and 24VAC is applied to the input. This alarm is reset when the 24VAC is removed.

## 7.7 Liebert XDP Warnings

**LOSS OF POWER**—Activated when the unit is On and operational and 24VAC power to the control is lost. This alarm will be emitted when power is restored to the control. The Liebert XDP will restart at a user-defined time delay after power is restored. Once activated, the alarm will remain activated for 30 minutes.

**PUMP 1 HRS EXCEED**—Activated when the Pump 1 Actual Hours exceeds the user-specified limit. To reset, Actual Hours must be reset to 0.

**PUMP 2 HRS EXCEED**—Activated when the Pump 2 Actual Hours exceeds the user-specified limit. To reset, Actual Hours must be reset to 0.

## 7.8 CANbus Communications

A Controller Area Network (CAN) is a specialized internal communication network. It allows a Liebert XDP, Liebert XDC and Liebert XD Smart Modules to communicate without a host computer. Networking the Liebert XDP or Liebert XDC to Smart Modules enables the Smart Modules to be controlled and monitored from the Liebert XDP or Liebert XDC.

Figure 7.6 below shows a typical Liebert XD system in a CANbus network. Liebert XD Smart Modules should be connected to the Liebert XDP or Liebert XDC that supplies the modules with refrigerant.

**Figure 7.6 Liebert XD system with CANbus**



**NOTE:** Only six Liebert XDV10S\* are shown. A maximum of 16 Liebert XDV10S\*, a maximum of 20 Liebert XDV8S\*, maximum of eight single-circuited Liebert XDH20S\*, five single-circuited Liebert XDH32S\*, maximum of eight Liebert XDO20S\*, or a maximum of 10 Liebert XDO16S\* can be connected together on a single CANbus.

Plan wiring runs for Unit-to-Module (U2M) communication when designing the layout of the conditioned space. In addition to general good wiring practices, take into account:

- Keep control and communication cables away from power cables to prevent electromagnetic interference.
- Do not bend cables to less than four times the diameter of the cable.
- Do not deform cables when securing in bundles or when hanging them.
- Keep cables away from devices that can introduce noise into them, such as machines, fluorescentlights, and electronics.
- Avoid stretching cables-tension when pulling cables should not exceed 25 pounds (11kg).
- Do not secure cables with any method that might damage them; use approved hangers, such as those used for telephone wire and RG-6 coaxial wire; available at most hardware stores.

- Do not run cables through conduit. Cables should be treated the same as any other data cable.

Running CANbus cables through conduit will increase the total length required.

## 7.9 Network Layout Options

The Liebert XDP and Liebert XDC have two CANbus ports each (P2 and P4) on the CAN Isolator in the low voltage side of the electrical box (see Figure 7.11 on page 170 and Figure 7.12 on page 171). This allows for two chains of the network to be created to minimize the total network length.

### 7.9.1 Remote Temperature/Humidity Sensor Placement and Connection to the CANbus

The Liebert XDP and Liebert XDC are shipped with two remote temperature/humidity sensors. One sensor should be placed closer to the Liebert XDP or Liebert XDC; the other should be placed in the warmest part of the cold aisle or in the return air stream of a computer room air conditioning unit, such as as the Liebert DS™ or Liebert CW™.

One shielded CANbus cable is provided with each sensor.

The remote sensors can be placed at the end of a chain or in the middle of a daisy chain as shown.

Refer to Figure 7.7 on the next page and Figure 7.8 on page 167 for examples of acceptable network layouts.

Figure 7.7 Modules on a single chain

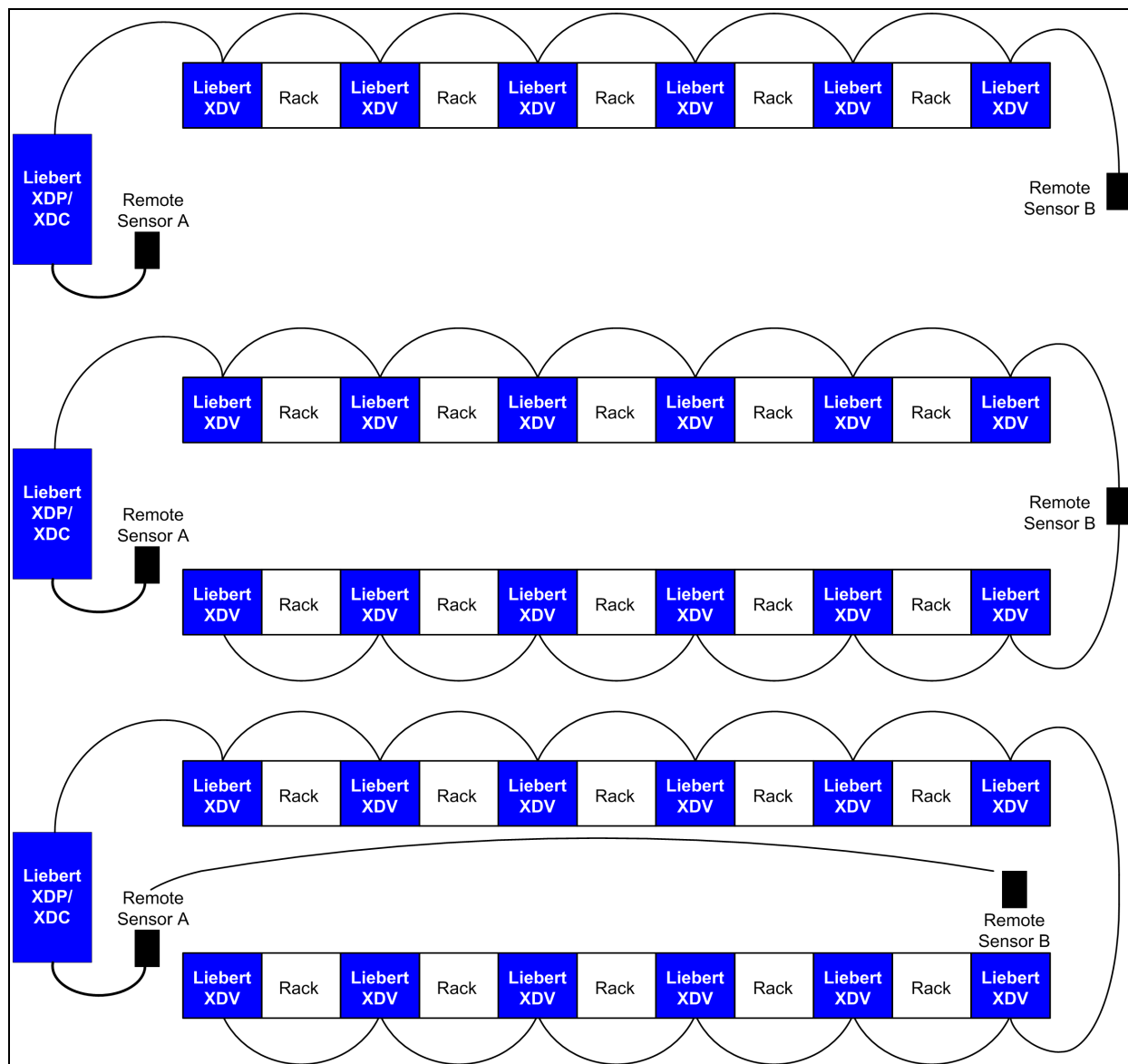
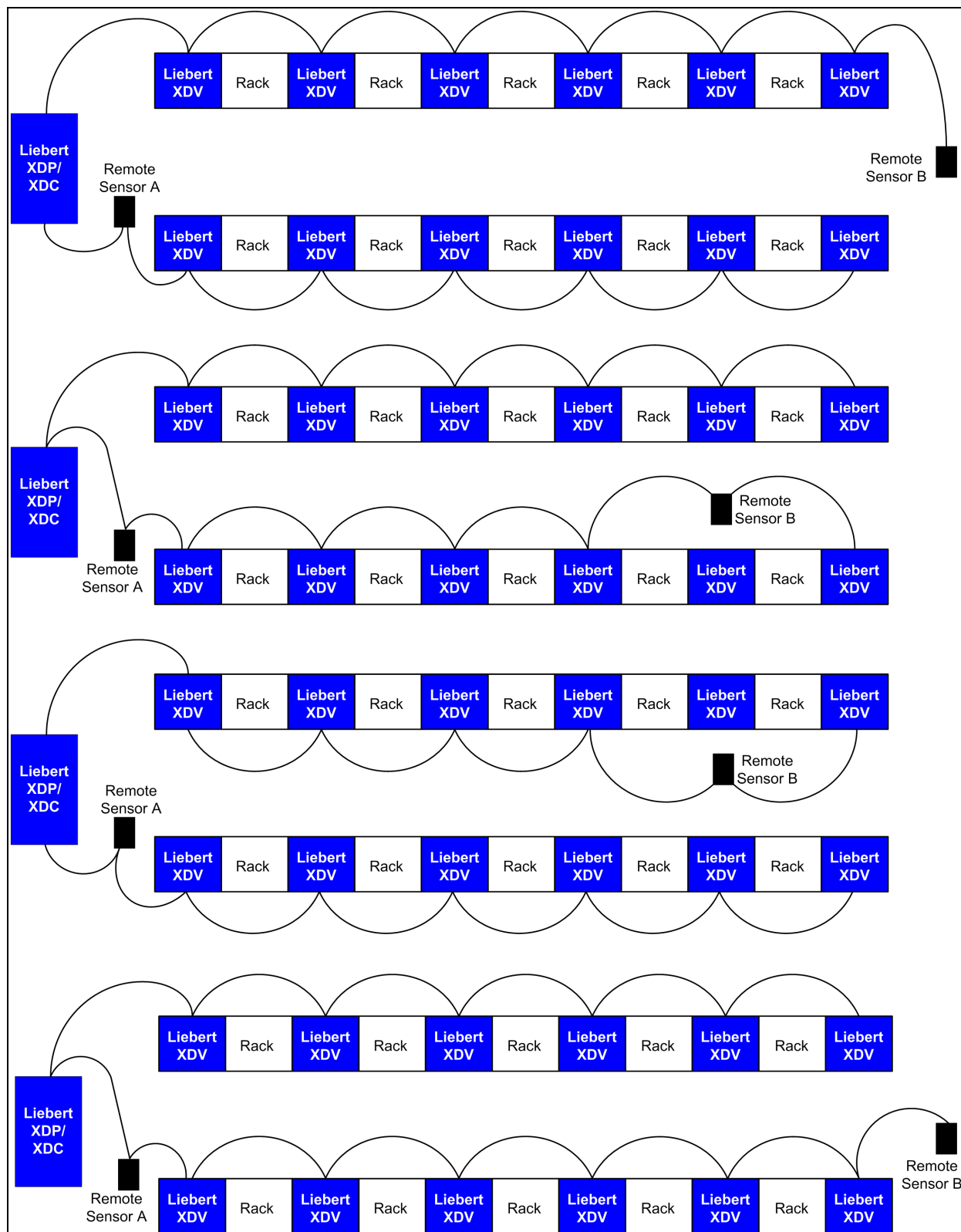

Figure 7.8 Modules on two chains



## 7.9.2 CANbus Maximum Length

The CANbus network (the sum of the two CANbus chains) has a maximum length limitation.

- If the Liebert XDP or Liebert XDC with iCOM does not have a CAN Isolator, the maximum distance is 150 ft. (46m) total network without measuring the final device voltage. The 150 ft. (46m) total must also include the remote temperature and humidity sensor cable lengths.
- If the Liebert XDP or Liebert XDC contains a CAN Isolator, the maximum distance is 300 ft. (91m). To exceed this length, the final device voltage must be measured.

## 7.10 CANbus Cables

The Liebert XDP may be connected to the Smart Modules with a CANbus cable. The shielded cable consists of three pairs of twisted wires with a 6-pin RJ12 connector.

### NOTICE

Risk of improper wiring. Can cause equipment damage.

Mismatching wire pins at the RJ12 connection will damage the CAN device. Extreme caution should be taken when making cables.

**Figure 7.9** CANbus cable

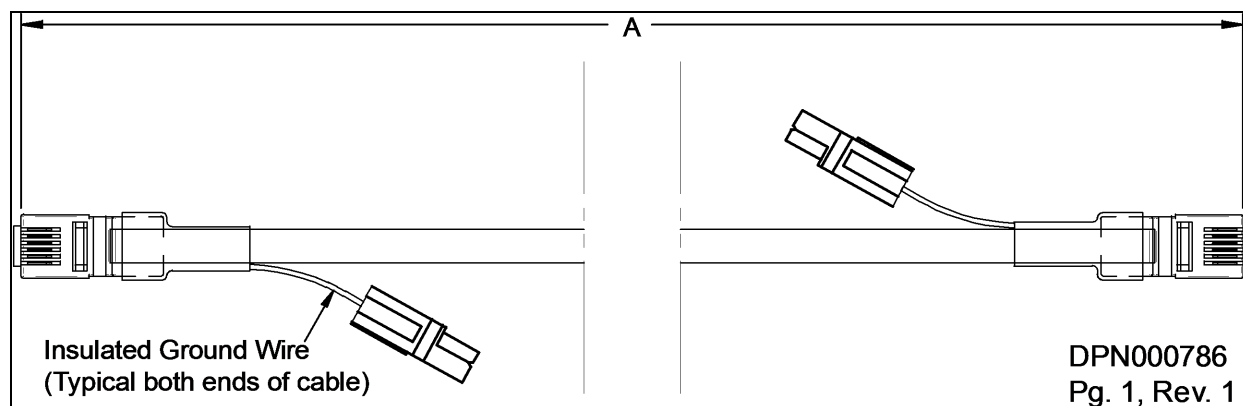

**Table 7.3** CANbus cable lengths and part numbers

Liebert Part #	Dimension A ft. (m)
300157G1	6 (1.8)
300157G2	10 (3)
300157G3	20 (6)
300157G4	30 (9.1)
300157G5	60 (18.3)
300157G6	90 (27.4)
300157G7	120 (36.6)
300157G8	150 (45.7)
300157G9	6.25 (1.9)
300157G10	3 (0.9)

**Table 7.3 CANbus cable lengths and part numbers (continued)**

Liebert Part #	Dimension A ft. (m)
300157G11	15 (4.6)
300157G13	40 (12.2)
300157G14	50 (15.2)
300157G15	70 (21.3)
300157G16	80 (24.4)
300157G17	100 (30.5)
300157G18	110 (33.5)

**Figure 7.10 CANbus cable plug**

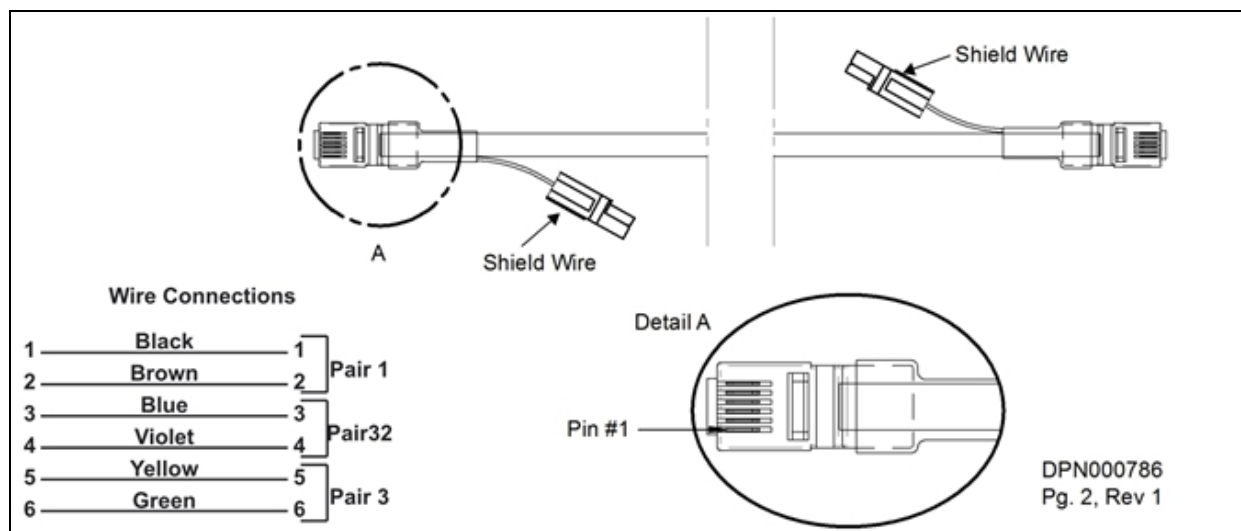

## 7.11 Connecting the CANbus Network

### 7.11.1 Connection to the Liebert XDP or Liebert XDC

The Liebert XDP and Liebert XDC have two CANbus ports each (P2 and P4) on the CAN Isolator in the low voltage side of the electrical box (see Figure 7.11 on the next page and Figure 7.12 on page 171). This allows for two chains of the network to be created to minimize the total network length.

Figure 7.11 CAN Isolator location within the Liebert XDP/XDC

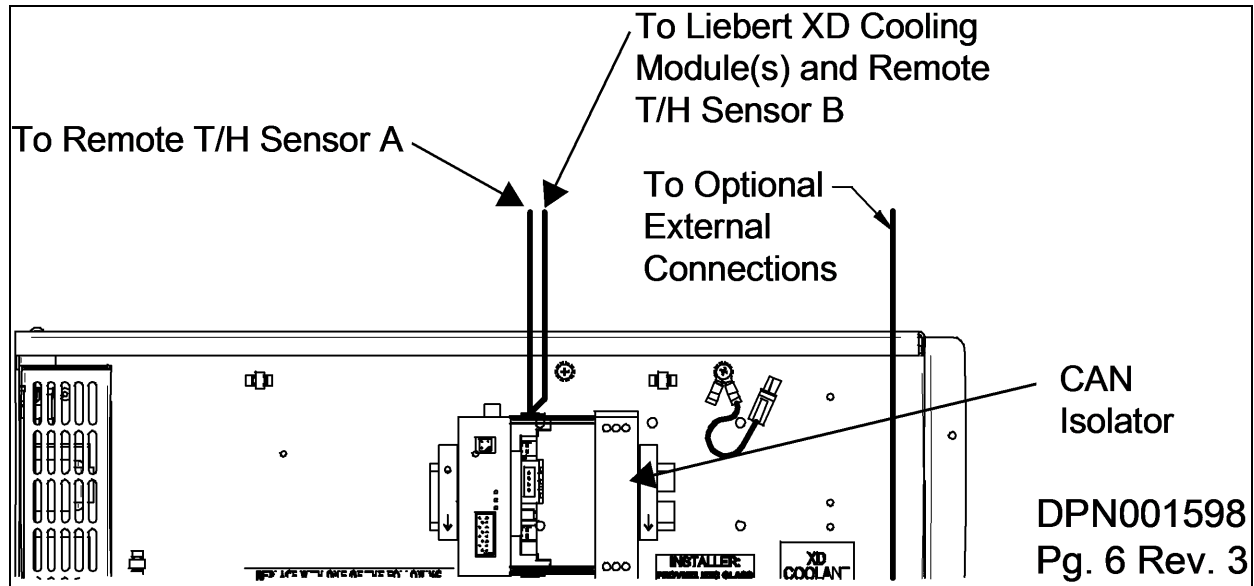
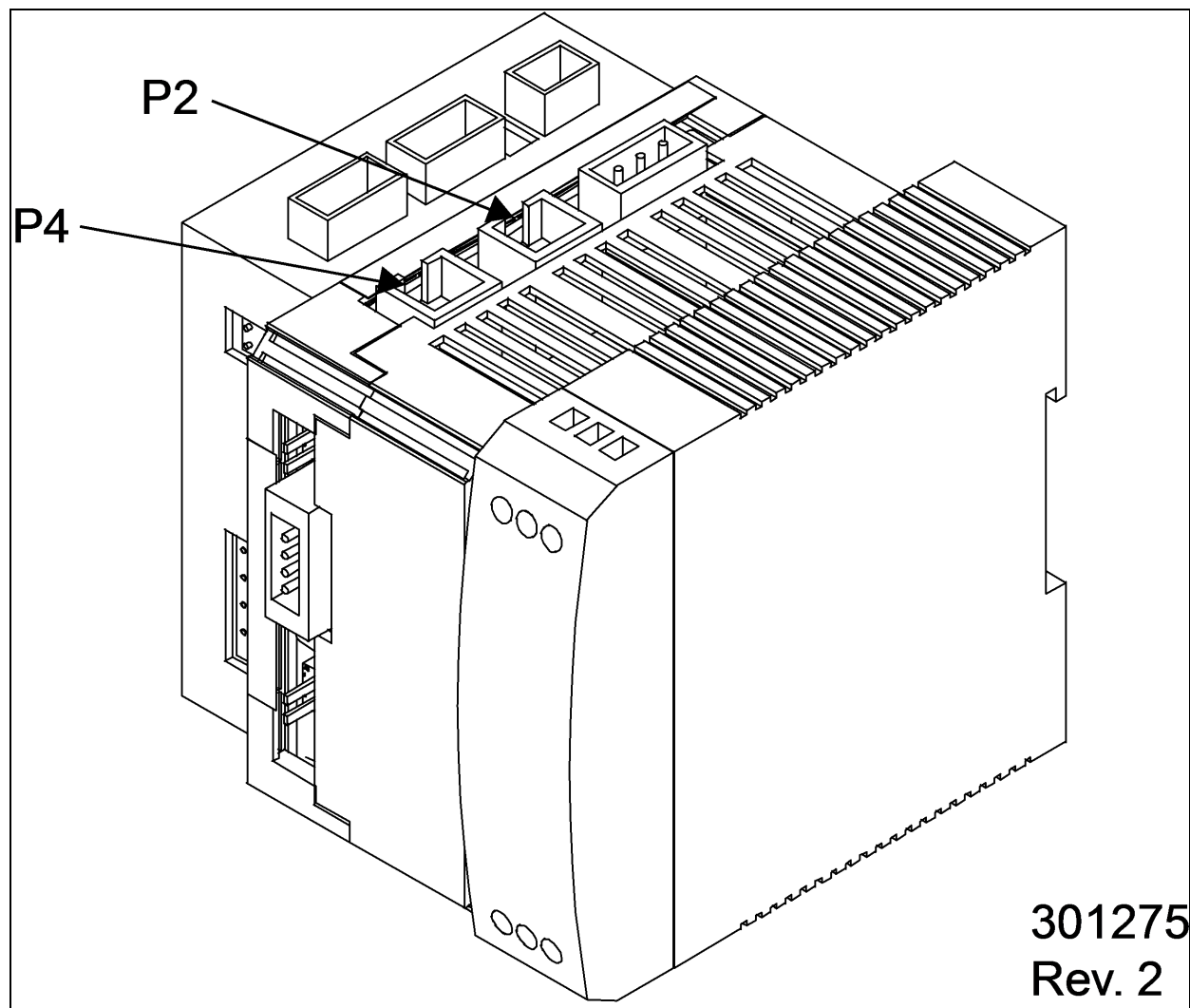



Figure 7.12 P2 and P4 locations on the CAN Isolator



301275  
Rev. 2

## 7.11.2 Connecting to the Liebert XDV Smart Modules

### Liebert XDV CANbus Port Locations

The CANbus ports on the Liebert XDV are on the rear of the unit. The cable from the Liebert XDP or Liebert XDC side will be connected to port P66. The leaving cable will be connected to port P67. See Figure 7.13 on the next page.

Figure 7.13 Liebert XDV Smart Module CANbus port locations

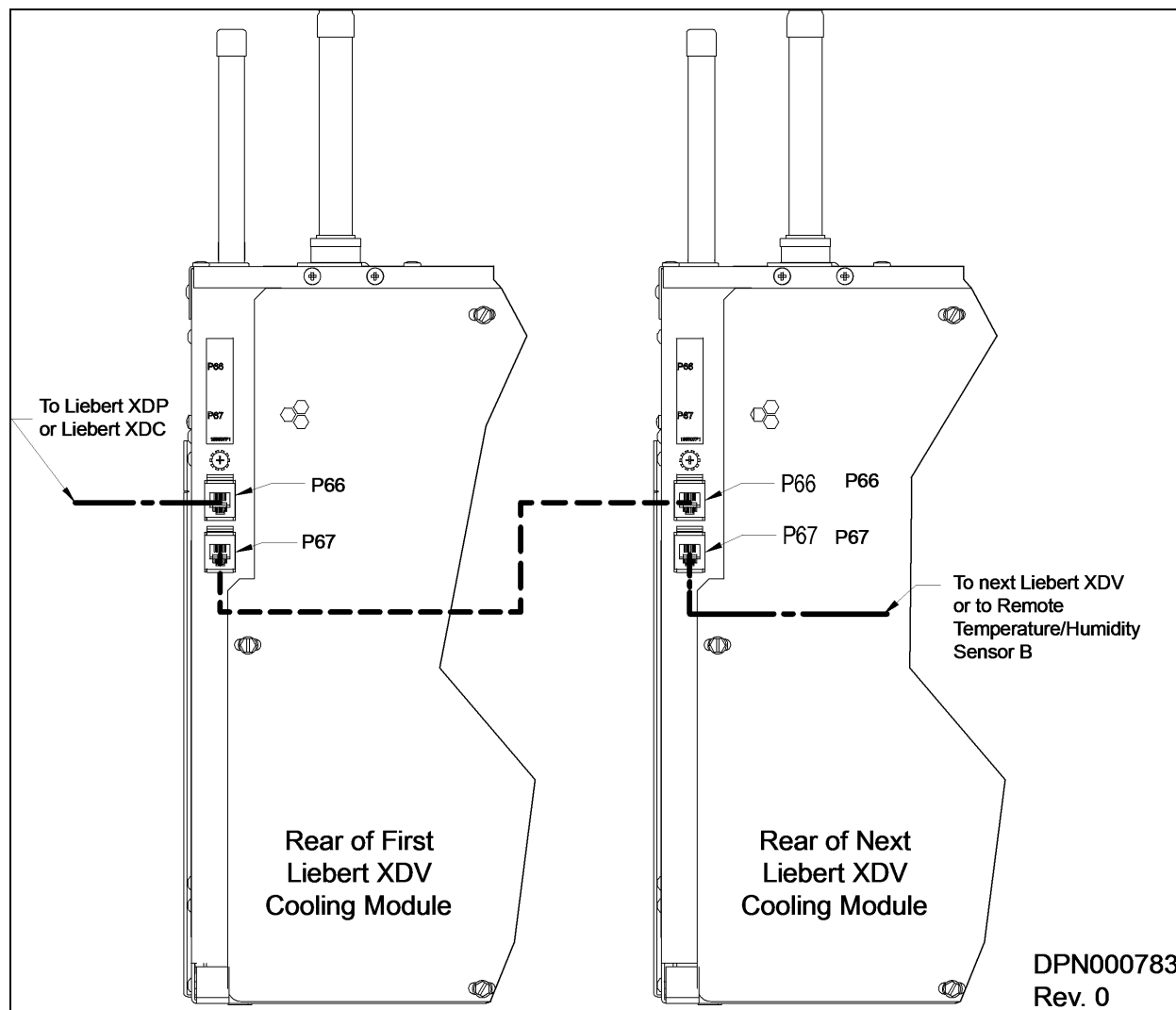

### 7.11.3 Connecting to the Liebert XDH Smart Modules

#### Liebert XDH CANbus Port Locations

The Liebert XDH CANbus ports are located on the side of the electrical box. The cable from the Liebert XDP or Liebert XDC side will be connected to Port P66. The leaving cable will be connected to Port P67. See Figure 7.14 on the facing page.

Figure 7.14 Liebert XDH CANbus port locations

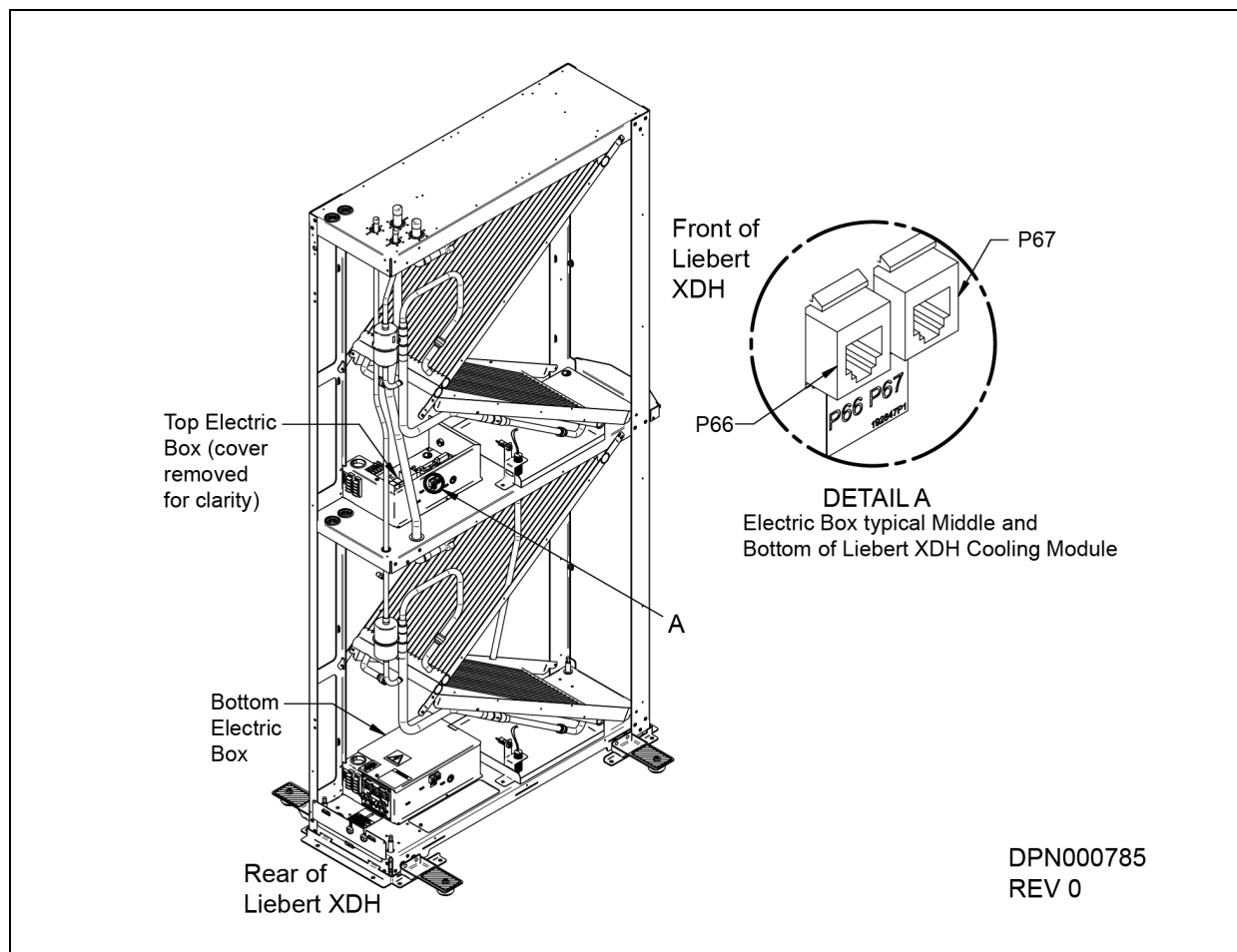

### Liebert XDH Single-Circuited CANbus Connections

For Liebert XDHs with both top and bottom circuits tied to the same Liebert XDP or Liebert XDC, the top and bottom control boards must be tied together using a CANbus cable with a length of 6.25ft. (1.9m). See Figure 7.15 on the next page.

**Figure 7.15 Single-circuited Liebert XDHs**

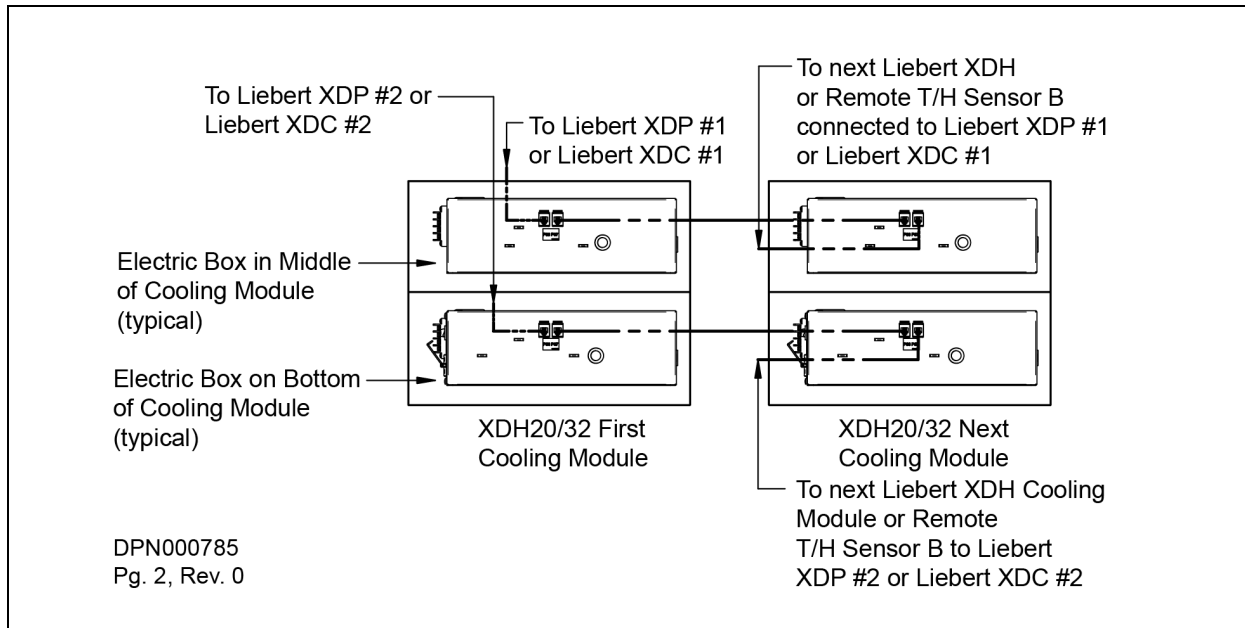

### Liebert XDH Dual-Circuited CANbus Connections

The Liebert XD Smart Modules are to be tied only to the Liebert XDP or Liebert XDC that they are mechanically connected to. For Liebert XDHs with the top and bottom circuits tied to different Liebert XDPs or Liebert XDCs, the control boards must be connected in the same manner. See Figure 7.16 below.

**Figure 7.16 Dual-circuited Liebert XDHs**

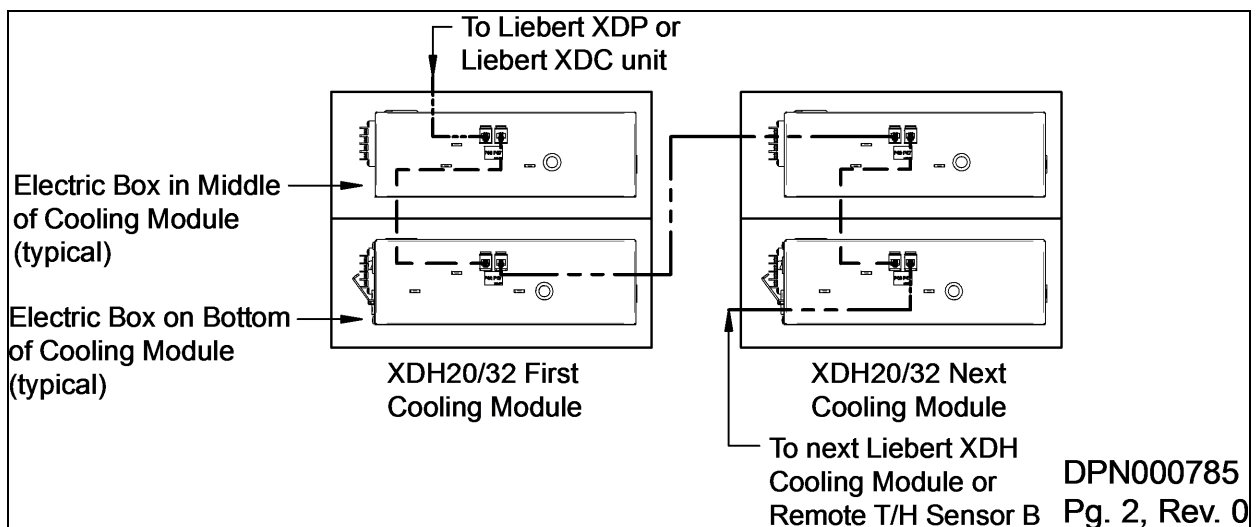

## 7.11.4 Connecting to the Liebert XD Smart modules

### Liebert XDO CANbus Port Locations

The Liebert XDO CANbus ports are located on the side of the electrical box. The cable from the Liebert XDP or Liebert XDC side will be connected to Port P66. The leaving cable will be connected to Port P67. See Figure 7.17 below.

Figure 7.17 Liebert XDO CANbus port locations

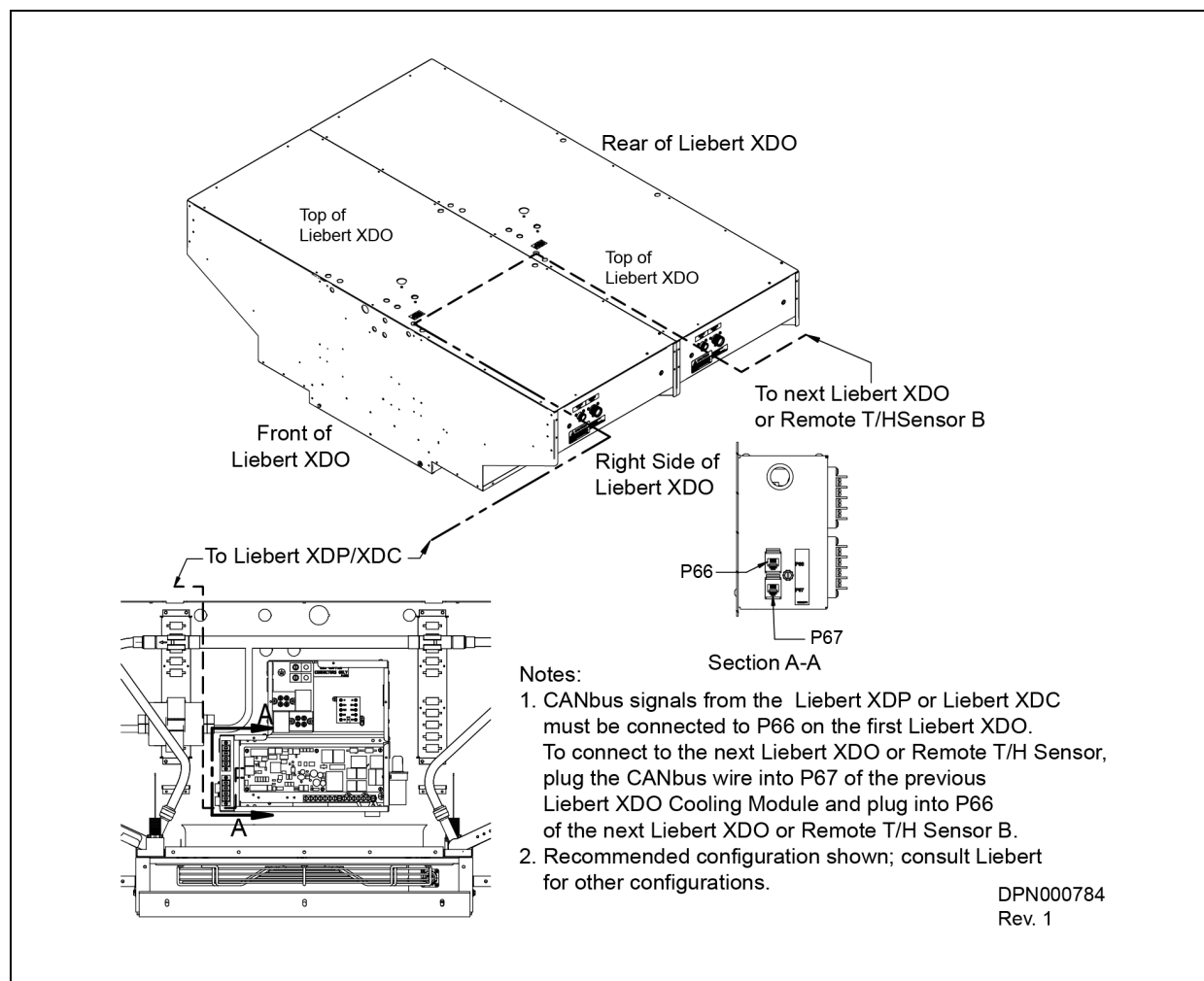

## 7.12 CANbus Termination

The last device in the chain must be terminated.

- The remote temperature and humidity sensors are terminated at the factory.
- The Liebert XD smart modules are not terminated at the factory. Improper termination will cause communication errors.

### 7.12.1 Remote Temperature and Humidity Sensors Termination

The control board is terminated at the factory. If a remote sensor is the last device in the CANbus chain, no changes are necessary. The termination jumper must be removed if a remote sensor is not the last device in the CANbus chain. Refer to the Liebert XD module user manual for terminating procedures.

### 7.12.2 Terminating a Smart Module

Liebert XD smart modules must be properly terminated or communication errors will result. Smart modules are shipped from the factory unterminated. If the smart module is the last device in the chain—in other words, the last module is not connected to a remote sensor—the smart module control board must be terminated. Refer to the Liebert XD module user manual for terminating procedures.

## 8 MONITORING

The Liebert XDC and Liebert XDP with iCOM allow for control down to the Smart Module level. Many of the Liebert XD system data points can be monitored through a building management system. For specific protocol mapping, refer to the protocol specific reference guide for registers, available at [www.VertivCo.com](http://www.VertivCo.com).

**Table 8.1 Liebert XDC/XDP monitoring points**

Data Description	Definitions
Auto Restart Delay	If power is lost, the control will delay this amount of time after power is restored before restarting the unit.
Calculated Next Maintenance Month	Calculated month of the next scheduled maintenance. Used in conjunction with (Calculated Next Maintenance Year).
Calculated Next Maintenance Year	Calculated year of the next scheduled maintenance. Used in conjunction with (Calculated Next Maintenance Month).
Circuit 1 Low Suction Pressure	Compressor Circuit 1 low suction pressure.
Circuit 2 Low Suction Pressure	Compressor Circuit 2 low suction pressure.
Compressor 1A High Head Pressure	Compressor 1A High Head Pressure
Compressor 1A Short Cycle	Compressor 1A short cycle. A short cycle is defined as turning On and Off a number of times over a set time period.
Compressor 1A State	Compressor 1A operational state.
Compressor 1B High Head Pressure	Compressor 1B high head pressure.
Compressor 1B Short Cycle	Compressor 1B short cycle. A short cycle is defined as turning On and Off a number of times over a set time period.
Compressor 1B State	Compressor 1B operational state.
Compressor 2A High Head Pressure	Compressor 2A high head pressure.
Compressor 2A Short Cycle	Compressor 2A short cycle. A short cycle is defined as turning On and Off a number of times over a set time period.
Compressor 2A State	Compressor 2A operational state.
Compressor 2B High Head Pressure	Compressor 2B high head pressure.
Compressor 2B Short Cycle	Compressor 2B short cycle. A short cycle is defined as turning On and Off a number of times over a set time period.
Compressor 2B State	Compressor 2B operational state.
Customer Input 1	Customer Input 1.
Dew Point Temperature	Dew point temperature, using the highest reading from all sensors.
Ext Air Over Temp Threshold	Threshold value used in the ([Ext Air Sensor A Over Temperature], [Ext Air Sensor B Over Temperature]...) events.
Ext Air Sensor A Dew Point Temp	Dew point temperature as measured by External Air Sensor A.
Ext Air Sensor A Humidity	Relative humidity as measured by External Air Sensor A.
Ext Air Sensor A Issue	The External Air Sensor A is disconnected or the signal is out of range.
Ext Air Sensor A Over Temperature	(Ext Air Sensor A Temperature) has exceeded (Ext Air Over Temp Threshold).

**Table 8.1 Liebert XDC/XDP monitoring points (continued)**

Data Description	Definitions
Ext Air Sensor A Temperature	Air temperature as measured by External Air Sensor A.
Ext Air Sensor A Under Temperature	(Ext Air Sensor A Temperature) has dropped below (Ext Air Under Temp Threshold).
Ext Air Sensor B Dew Point Temp	Dew point temperature as measured by External Air Sensor B.
Ext Air Sensor B Humidity	Relative humidity as measured by External Air Sensor B.
Ext Air Sensor B Issue	The external air sensor B is disconnected or the signal is out of range.
Ext Air Sensor B Over Temperature	(Ext Air Sensor B Temperature) has exceeded (Ext Air Over Temp Threshold).
Ext Air Sensor B Temperature	Air temperature as measured by External Air Sensor B.
Ext Air Sensor B Under Temperature	(Ext Air Sensor B Temperature) has dropped below (Ext Air Under Temp Threshold).
Ext Air Under Temp Threshold	Threshold value used in the ([Ext Air Sensor A Under Temperature], [Ext Air Sensor B Under Temperature]...) events.
Ext Dew Point Over Temp Threshold	Threshold value used in the (Ext Dew Point Over Temperature) event.
Ext Dew Point Over Temperature	At least one dew point temperature reading ([Ext Air Sensor A Dew Point Temp], [Ext Air Sensor B Dew Point Temp]...) has exceeded (Ext Dew Point Over Temp Threshold).
Fan Issue	One or more fans are not operating within their operational parameters.
Hot Gas Solenoid Valve 1 Position	Hot gas solenoid Valve 1 position.
Hot Gas Solenoid Valve 2 Position	Hot gas solenoid Valve 2 position
Hot Gas Valve 1 Open Position	Hot gas Valve 1 open position.
Hot Gas Valve 2 Open Position	Hot gas Valve 2 open position.
Maintenance Ramp	The ratio of operations performed to the calculated operations available between maintenance intervals.
Minimum Room Temperature Set Point	Minimum desired room air temperature. If the room air temperature falls below this set point, the unit will reduce the cooling.
Pump 1 Loss of Flow	Loss of flow is detected in Pump 1. The loss of flow condition occurs when no differential pressure is detected across the pump.
Pump 1 State	Pump 1 operational state.
Pump 2 Loss of Flow	Loss of flow is detected in Pump 2. The loss of flow condition occurs when no differential pressure is detected across the pump.
Pump 2 State	Pump 2 operational state.
Pump Short Cycle	Pumps have short cycled. A short cycle is defined as turning On and Off a number of times over a set time period.
Shutdown - Loss Of Power	System lost power. This event becomes active when the unit is powered on following an unexpected loss of power.
Supply Refrig Over Temp Threshold	Threshold value used in the (Supply Refrigerant Over Temp) event.
Supply Refrig Over Temp Threshold	Threshold value used in the (Supply Refrigerant Over Temp) event.
Supply Refrigerant Over Temp	Event that is activated when (Supply Refrigerant Temperature) exceeds (Supply Refrig Over Temp Threshold). The event is deactivated when the temperature drops below the threshold.
Supply Refrigerant Temp Sensor Issue	The supply refrigerant temperature sensor is disconnected or the signal is out of range.



**Table 8.1 Liebert XDC/XDP monitoring points (continued)**

Data Description	Definitions
Supply Refrigerant Temperature	Supply refrigerant temperature.
Supply Refrigerant Under Temp	(Supply Refrigerant Temperature) has dropped below a specified threshold.
System Condensation Detected	System condensation detected.
System Control Mode	System Control Mode
System Date and Time	The system date and time
System Event Acknowledge/Reset	Reset and/or acknowledge all events.
System On/Off Control	Turn system functionality On or Off.
System Operating State	Current operating state of the system.
System Status	The operating status for the system

**Table 8.2 Liebert XD Smart Module monitoring points**

Data Description	Definitions
Cold Aisle Over Temp Threshold	Upper threshold value used in the (Cold Aisle Temp Out of Range) event.
Cold Aisle Over Temp Threshold	Upper threshold value used in the (Cold Aisle Temp Out of Range) event.
Cold Aisle Temp Out of Range	The air temperature in the cold aisle is either above (Cold Aisle Over Temp Threshold) or below (Cold Aisle Under Temp Threshold).
Cold Aisle Under Temp Threshold	Lower threshold value used in the (Cold Aisle Temp Out of Range) event.
Cold Aisle Under Temp Threshold	Lower threshold value used in the (Cold Aisle Temp Out of Range) event.
Communication Status	Communication status of remote device.
Cooling Capacity	Cooling capacity in use, expressed as a percentage of the maximum rated capacity.
Cooling Capacity	Cooling capacity in use, expressed in kilowatts.
Ext Fan Issue	One or more fans are not operating within their operational parameters.
Ext Fan Issue - Event Control	Enable/disable the activation of the (Ext Fan Issue) event. If set to "disabled," the event will not be annunciated. This implies that the event will not be placed in any active event list or in any event history list.
Ext Fan Issue - Event Type	The event type for the (Ext Fan Issue) event.
Ext Remote Shutdown	Unit is shut down by a remote signal.
Ext Remote Shutdown - Event Control	Enable/disable the activation of the (Remote Shutdown) event. If set to 'disabled', the event will not be annunciated. This implies that the event will not be placed in any active event list or in any event history list.
Ext Remote Shutdown - Event Type	The event type for the (Remote Shutdown) event.
Ext System Condensation Detected	External system condensation detected.
Ext System Condensation Detected - Event Control	Enable/disable the activation of the (Ext System Condensation Detected) event. If set to "disabled," the event will not be annunciated. This implies that the event will not be placed in any active event list or in any event history list.
Ext System Condensation Detected - Event Type	The event type for the (Ext System Condensation Detected) event.

**Table 8.2 Liebert XD Smart Module monitoring points (continued)**

Data Description	Definitions
Fan Button Control	Enable or disable the buttons from controlling the state of the fans.
Fan On/Off Control	Turn system fans On or Off.
Hot Aisle Over Temp Threshold	Upper threshold value used in the (Hot Aisle Temp Out of Range) event.
Hot Aisle Over Temp Threshold	Upper threshold value used in the (Hot Aisle Temp Out of Range) event.
Hot Aisle Temp Out of Range	The air temperature in the Hot aisle is either above (Hot Aisle Over Temp Threshold) or below (Hot Aisle Under Temp Threshold).
Hot Aisle Under Temp Threshold	Lower threshold value used in the (Hot Aisle Temp Out of Range) event.
Hot Aisle Under Temp Threshold	Lower threshold value used in the (Hot Aisle Temp Out of Range) event.
Primary Fan Group State	Current operational state of the primary fan group.
Sensor Issue	One or more sensors are disconnected or the signals are out of range.
Sensor Issue - Event Control	Enable/disable the activation of the (Sensor Issue) event. If set to 'disabled', the event will not be annunciated. This implies that the event will not be placed in any active event list or in any event history list.
Sensor Issue - Event Type	The event type for the (Sensor Issue) event.
Fan Economy Mode	Mode in which system secondary fans are to be controlled.
Fan State	Current operational state of a group of fans.
Module Refrigerant Temperature	Refrigerant temperature as measured by Module Sensor
Module Sensor 1 Temperature	Air temperature as measured by Module Sensor 1
Module Sensor 2 Temperature	Air temperature as measured by Module Sensor 2
Module Sensor 3 Temperature	Air temperature as measured by Module Sensor 3
Visual ID Control	Visual identification control to display an LED flashing sequence, allowing it to be visually located.

**Table 8.3 System data points**

Data Description	Definitions
Unit Communication Lost	Master has lost communication with one or more networked units.
RAM Battery Issue	RAM or RAM backup battery is not operating correctly.
Master Unit Communication Lost	Communication with master unit has been lost.
Remote Shutdown	Unit is shut down by a remote signal.
Unit Code Missing	Unit code has not been entered and saved.
Unit On	Unit was turned on.
Unit Off	Unit was turned Off.
Unit Standby	Unit was placed in standby mode.

**Table 8.3 System data points (continued)**

Data Description	Definitions
Unit Partial Shutdown	An event has occurred requiring some system components to be shutdown and disabled.
Unit Shutdown	An event has occurred requiring the unit to be shutdown and disabled to prevent damage to the system.
Maintenance Due	The calculated maintenance date has been reached.
Maintenance Completed	Maintenance has been completed on the unit.
System Operating State Reason	The reason the system is in the current operating state.
System Date and Time	The system date and time

**Table 8.4 Communication cards for Liebert XD units**

Communication Card	Protocol
IS-WEBL	SNMPv1, SNMPv2c, HTTP, HTTPS, Email, SMS, Telnet, Liebert Protocol
IS-485L	Modbus 485
IS-IPBML	HTTP, HTTPS, Telnet, Modbus, IP, BACnet IP
IS-485EXI	Liebert SiteScan®

This page intentionally left blank.

## 9 SPECIFICATIONS AND MODEL NUMBER NOMENCLATURE

Table 9.1 Liebert XDCF specifications

Models	XD-CF-10-BP-*, XD-CF-10-TP-*
	XD-CF-10-BPE-*, XD-CF TPE-*
Cooling capacity, maximum	10kWH / 2.8 Tons / 34,000 BTUh
Conditions	55°F (13°C) entering fluid temperature, 50°F (10°C) or lower dew point
Dimensions, inches (mm)	
Height – including pipe connections	31-3/8" (797mm)
Width	13-7/16" (341mm)
Depth	7-5/16" (186mm)
Weight, lb (kg)	
Module only	18 (8.2)
Shipping weight	30 lb. (13.06 kg)
Pipe connections	
Refrigerant Supply from Liebert XDP/Liebert XDC	1/2" threaded one-shot coupling on the module
Refrigerant Return to Liebert XDP/Liebert XDC	5/8" threaded one-shot coupling on the unit
Cabinet exterior finish	Gray
Agency	
Safety	CSA — CE

Figure 9.1 Liebert XDCF model number nomenclature

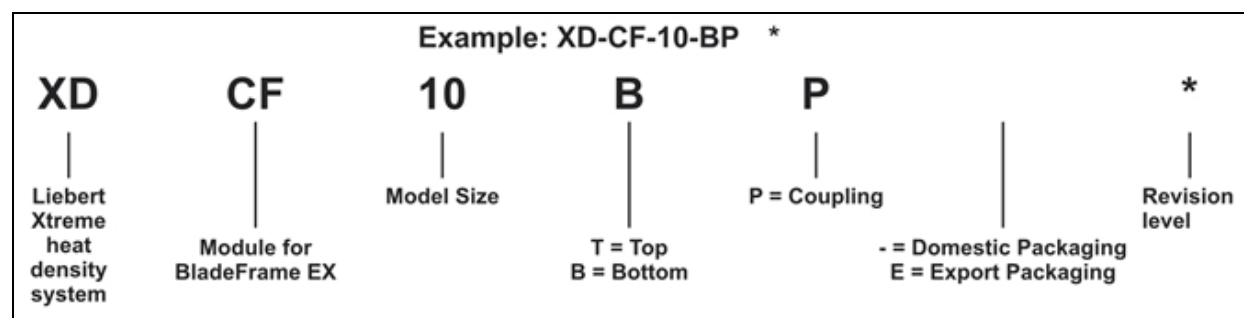

**Table 9.2 Liebert XDH20 specifications**

Models	XDH20BK <sup>1</sup> XDH20SK <sup>1</sup> (60Hz)	XDH20BS <sup>1</sup> XDH20SS <sup>1</sup> (50/60Hz)
Cooling Capacity	XDH20, 60Hz Nominal (98°F [37°C] EAT): 22kW/6.3 Tons XDH20, 60Hz Maximum(105°F [41°C] EAT): 25.3kW/7.2 Tons XDH20, 50Hz Nominal (98°F [37°C] EAT): 21.6kW / 6.1 Tons XDH20, 50Hz Maximum(105°F [41°C] EAT): 25.3kW/7.2 Tons	
Conditions	Capacity rating is @ 55°F (13°C) Entering Fluid Temperature and 50°F (10°C) or lower dew point	
Electrical Requirements		
Input	120V-1ph-60Hz	220-240V-1ph-50Hz, CE / 208-240V-1ph-60Hz, CSA
Input Power Connections	Two IEC320-C14 power inlets and two IEC power cords with NEMA 5-15P plugs	Two IEC320-C14 power inlets and two IEC power cords with IEC320-C14 plugs
Full Load Amps	5	2.5
Power Consumption, Nominal, Watts	600	575
Dimensions, inches (mm)		
Height—Module Only	78 (1981)	
Height—including Pipe Connections	80 (2032)	
Width	12 (305)	
Depth	42 (1067)	
Weight, lb (kg)		
Module Only	233 (106)	233 (106)
Shipping Weight	317 (144)	317 (144)
<b>Number of Fans</b>	6	
Airflow, Nominal, ft <sup>3</sup> /min (m <sup>3</sup> /hr)	2500 (4248)	2428 (4125)
Audible Noise, Sound Power	81 dBA	81 dBA
Pipe Connections		
Refrigerant Supply	1/2" OD, Cu	
Refrigerant Return	7/8" OD, Cu	
Serviceable Parts	Fans and electrical components	
Cabinet Exterior Finish	Black, matte finish, heat-fused powder coat	
Options		
Smart Module control board (factory-installed)	Dry contact (24 VAC - 1A maximum)	
Pre-Charged Refrigerant	R-134a refrigerant, one-shot connections	
	Uni-directional or bi-directional	
Agency		
Approvals	CSA 60Hz	CE 50Hz, CSA 50/60Hz
1. Refer to Figure 9.2 on page 186 for complete part number.		

**Table 9.3 Liebert XDH32 specifications**

Models	XDH32BK <sup>1</sup> XDH32SK <sup>1</sup> (60Hz)	XDH32BS <sup>1</sup> XDH32SS <sup>1</sup> (50/60Hz)
Cooling Capacity	XDH32, 60Hz Nominal (98°F [37°C] EAT): 30kW/8.5 Tons XDH32, 60Hz Maximum(105°F [41°C] EAT): 34kW/9.7 Tons XDH32, 50Hz Nominal (98°F [37°C] EAT): 30kW / 8.5 Tons XDH32, 50Hz Maximum(103°F [39°C] EAT): 34kW/9.7 Tons	
Conditions	Capacity rating is @ 55°F (13°C) Entering Fluid Temperature and 50°F (10°C) or lower dew point	
Electrical Requirements		
Input	120V-1ph-60Hz	220-240V-1ph-50Hz, CE / 208-240V-1ph-60Hz, CSA
Input Power Connections	Two IEC320-C14 power inlets and two IEC power cords with NEMA 5-15P plugs	Two IEC320-C14 power inlets and two IEC power cords with IEC320-C14 plugs
Full Load Amps	10	5
Power Consumption, Nominal, Watts	1200	1150
Dimensions, inches (mm)		
Height—Module Only	78 (1981)	
Height—Including Pipe Connections	80 (2032)	
Width	12 (305)	
Depth	42 (1067)	
Weight, lb (kg)		
Module Only	246 (112)	246 (112)
Shipping Weight	330 (150)	330 (150)
Number of Fans	6	
Airflow, Nominal, ft <sup>3</sup> /min (m <sup>3</sup> /hr)	4000 (6796)	3850 (6541)
Audible Noise, Sound Power	86 dBa	86 dBa
Pipe Connections		
Refrigerant Supply	1/2" OD, Cu	
Refrigerant Return	7/8" OD, Cu	
Serviceable Parts	Fans and electrical components	
Cabinet Exterior Finish	Black, matte finish, heat-fused powder coat	
Options		
Smart Module control board (factory-installed)	Dry contact (24VAC - 1A maximum)	
Pre-Charged Refrigerant	R-134a refrigerant, one-shot connections	
	Uni-directional or bi-directional	
Agency		
Approvals	CSA 60Hz	CE 50Hz, CSA 50/60Hz
Refer to Figure 9.2 on the next page for complete part number.		

Figure 9.2 Liebert XDH model number nomenclature

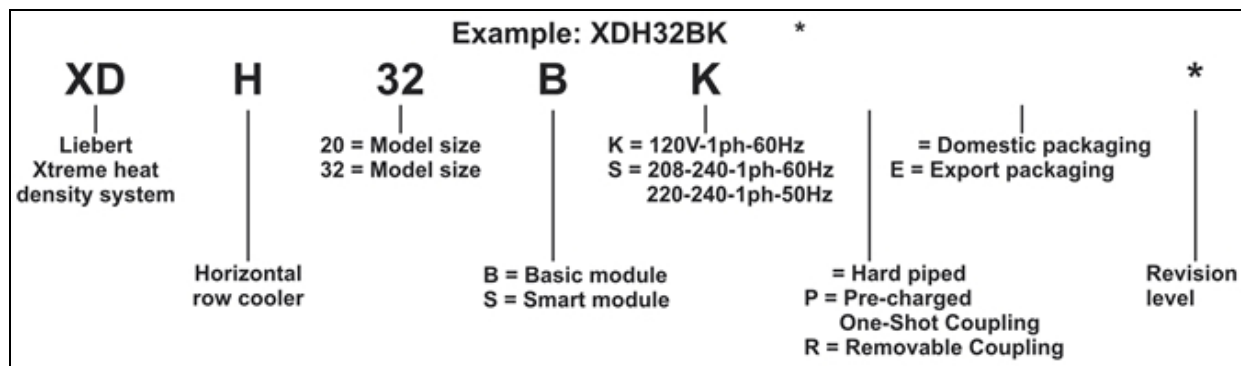

Table 9.4 Liebert XDO16 specifications

Models	XDO16BK <sup>1</sup> XDO16SK <sup>1</sup> (60Hz)	XDO16BS <sup>1</sup> XDO16SS <sup>1</sup> (60Hz)	XDO16BS <sup>1</sup> XDO16SS <sup>1</sup> (50Hz)
Cooling Capacity	Nominal (85°F [29.4°C] EAT): 16kW / 4.5 Tons Maximum (90°F [32°C] EAT): 17.3 kW / 4.9 Tons		Nominal (85°F [29.4°C] EAT): 14kW/4.0Tons Maximum (93°F [34°C] EAT): 17.3 kW / 4.9 Tons
Conditions	Capacity rating is @ 55°F (13°C) Entering Fluid Temperature and 50°F or lower dew point		
Electrical Requirements			
Input Voltage	1ph-60Hz-120V	1ph-60Hz-240V	1ph-50Hz-240V
Input Power Connections	Terminal blocks provided internal to module		
Full Load Amps	2.7A @ 120V	1.50 @ 230V	1.50 @ 230V
Wire Size Amps	3.4	2.0	2.0
Overcurrent Protection Device	15	15	15
Power consumption, nominal, watts	335	350	350
Dimensions, inches (mm)			
Length	72-1/4 (1835)		
Width	24-1/8 (613)		
Height	22-1/2 (572) not including electrical and piping access		
Weight, lb (kg)			
Module only	150 (68)		
Shipping weight	238 (108)	296 (134)	
Installed, with refrigerant, without options	155 (70)		
Number of Fans	1	1	1
Airflow, Nominal, ft <sup>3</sup> / min (m <sup>3</sup> / hr)	2700 (4587)		2250 (3822)
Audible Noise	85 dBa sound power		83 dBa sound power
Pipe Connections			
Refrigerant Supply from Liebert XDP/Liebert XDC	1/2" OD, Copper		



**Table 9.4 Liebert XDO16 specifications (continued)**

Refrigerant Return to Liebert XDP/Liebert XDC	7/8" OD, Copper		
Serviceable Parts	Fan and electrical components		
Exterior Finish – Bottom, Sides, Front and Rear	Black, matte finish, heat-fused powder coat		
Exterior Finish - Top	Hot-dipped galvanized steel		
Agency			
Approvals	CSA 60 Hz	CSA 60Hz	CE 50Hz
1. Refer to Figure 9.3 on the next page for full part number.			

**Table 9.5 Liebert XDO20 specifications**

Models	XDO20BK <sup>1</sup>	XDO20BS <sup>1</sup>	
	XDO20SK <sup>1</sup>	XDO20SS <sup>1</sup>	
	60Hz	60Hz	50Hz
Cooling Capacity	Nominal (92°F [33°C] EAT): 20kW / 5.7 Tons Maximum (100°F [38°C] EAT): 23.1kW / 6.6 Tons		Nominal (92°F [33°C] EAT): 17.7kW / 5 Tons Maximum (103°F [39°C] EAT): 23.1kW / 6.6 Tons
Conditions	Capacity rating is @ 55°F (13°C) Entering Fluid Temperature and 50°F (10°C) or lower dew point		
Electrical Requirements			
Input Voltage	1ph-60Hz-120V	1ph-60Hz-220-240V	1ph-50Hz-220-240V
Input Power Connections	Terminal blocks provided internal to module		
Full Load Amps	2.7A @ 120V	1.64A @ 230V	1.64A @ 230V
Wire Size Amps	3.4	2.0	2.0
Overcurrent Protection Device	15	15	15
Power consumption, nominal, watts	335	350	350
Dimensions, inches (mm)			
Length	72-1/4 (1835)		
Width	24-1/8 (613)		
Height	22-1/2 (572) not including electrical and piping access		
Weight, lb (kg)			
Module only	150 (68)		
Shipping weight	238 (108)	296 (134)	
Installed, with refrigerant, without options	155 (70)		
Number of Fans	1	1	1
Airflow, Nominal, ft <sup>3</sup> / min (m <sup>3</sup> / hr)	2700 (4590)		2250 (3820)
Audible Noise	85 dBA sound power		83 dBA sound power
Pipe Connections (without flex pipe)			
Refrigerant Supply from Liebert XDP/Liebert XDC	1/2" OD, Copper		

**Table 9.5 Liebert XDO20 specifications (continued)**

Models	XDO20BK <sup>1</sup> XDO20SK <sup>1</sup>	XDO20BS <sup>1</sup> XDO20SS <sup>1</sup>	
	60Hz	60Hz	50Hz
Refrigerant Return to Liebert XDP/Liebert XDC	7/8" OD, Copper		
Serviceable Parts	Fan and electrical components		
Exterior Finish – Bottom, Sides, Front and Rear	Black matte finish, heat-fused powder coat		
Exterior Finish - Top	Hot-dipped galvanized steel		
Agency			
Approvals	CSA 60 Hz		CE 50Hz
1. Refer to Figure 9.3 below for full part number.			

**Figure 9.3 Liebert XDO model number nomenclature**

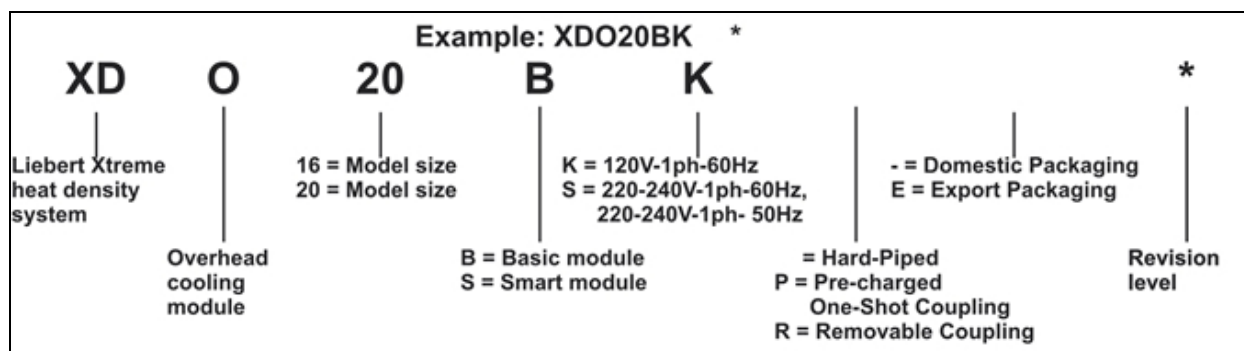

**Table 9.6 Options for Liebert XDO20 and Liebert XDO16**

Option	Liebert XDO - 60Hz Models	Liebert XDO - 50Hz Models
Lighting Fixtures (ship loose)	2 Liebert XDOs per lighting unit; 120V or 277V; 4' standard fluorescent tubes (not included)	
Power, optional lighting fixture	0.9A per 120V light fixture; 0.4A per 277V light fixture	None
Smart Module control board (factory-installed)	Dry contact 24VAC - 1A maximum	
Pre-Charged Refrigerant	R-134a Refrigerant, one-shot connections	

**Table 9.7 Liebert XDO dimensions—domestic and export**

Model	Shipping Dimensions, inches (mm)						Module Dimension Unpacked, inches (mm)		
	Domestic			Export					
	Length	Width	Height	Length	Width	Height	Length	Width	Height *
All Models		30 (762)	30 (762)	83 (2108)	30 (762)	30 (762)	72-1/4 (1835)	24-1/8 (613)	25-1/2 (648)

\* Includes piping connections

**Table 9.8 Liebert XDR20 specifications**

Models	XDR20B1- *	XDR20B1P * (Precharged R134a)	XDR20B1R *
Cooling Capacity, Nominal, rated at 104°F (40°C) EAT & 2400ft <sup>3</sup> /m (68m <sup>3</sup> /m)	20.5 kW (5.8 tons)		
Conditions	55°F (13°C) entering fluid temperature 50°F (10°C) or lower dew point		
Dimensions, inches (mm)			
Height, Including Pipe Connections	82-3/8 (2093)	83-1/2 (2121)	80 (2032)
Width With Handles Attached	27-3/8 (695)		
Handles Removed	23-1/2 (597)		
Depth	6-1/2 (165)		
Shipping Length	90 (2286)		
Shipping Width	30-1/2 (775)		
Shipping Depth	15-1/2 (394)		
Max Shipping Depth (4 modules)	62 (1575)		
Weight, lb (kg)			
Module Only	130 (59)	133 (60)	130 (59)
Shipping	225 (103)	228 (104)	225 (103)
Pipe Connections			
Refrigerant Supply	1/2" OD Type ACR		
Refrigerant Return	7/8" OD Type ACR		
Exterior Finish			
Safety	CSA, CE Approved		

\* Refer to Figure 9.4 on the next page for the complete part number.

**Table 9.9 Liebert XDR rack mounting kit**

Rack	Part #
Knurr Miracel	198163G1
Dell PowerEdge 4210	199050G1
HP 10642	199051G1
APC AR3100	199054G1

**Figure 9.4 Liebert XDR model number nomenclature**

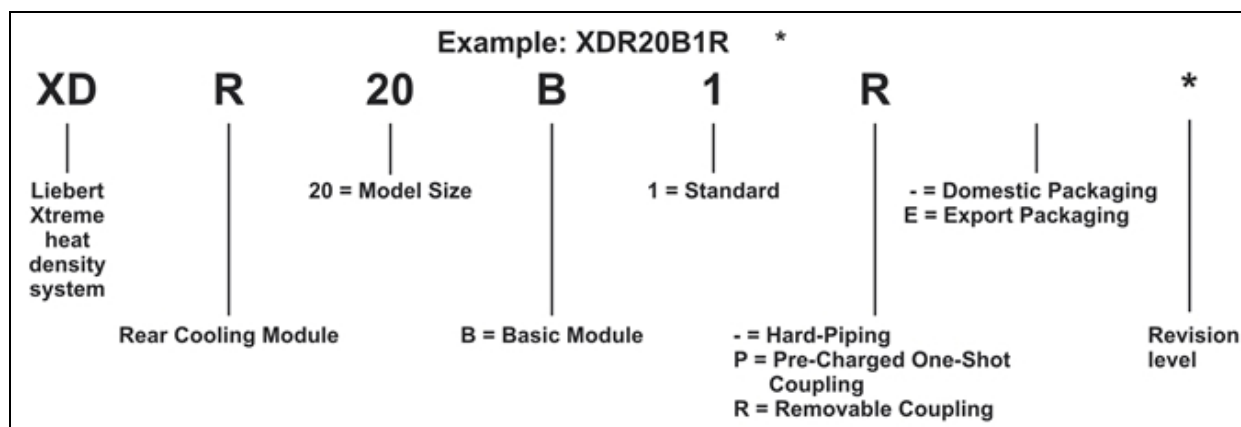

**Table 9.10 Liebert XDV8 specifications**

Models	XDV8BK*	XDV8BT*	XDV8BS*	
	XDV8SK*	XDV8ST*	XDV8SS*	
	60 Hz	60 Hz	50 Hz	50 Hz
Cooling Capacity	Nominal (92°F [33°C] EAT): 8kW / 2.3 Tons Maximum (95°F [35°C] EAT): 8.7kW / 2.5 Tons		Nominal (92°F [33°C] EAT): 7kW/2.0 Tons Maximum (103°F [39°C] EAT): 8.7kW/2.5Tons	
Conditions	Capacity rating is @ 55°F (13°C) Entering Fluid Temperature and 50°F (10°C) or lower dew point, rear air inlet.			
Electrical Requirements				
Input	120V model: 1ph-60 Hz	230V model: 1ph-60 Hz	230V model: 1ph-50 Hz	
Input power connections	2 power connections, each model			
Full Load Amps	120V model: 2.0A	230V model: 1.0A		
Power consumption, nominal, watts	180	190	190	190
Dimensions, in. (mm)				
Height – module only	14 (355) not including pipe connections			
Height – including pipe connections	18-5/8 (473)			
Width	22-7/8 (581)			
Depth – Top	39-1/2 (1003)			

**Table 9.10 Liebert XDV8 specifications (continued)**

Models	XDV8BK*	XDV8BT*	XDV8BS*	
	XDV8SK*	XDV8ST*	XDV8SS*	
	60 Hz	60 Hz	50 Hz	50 Hz
Depth – Bottom	29-5/8 (752)			
Weight, lb (kg)				
Module only	77 (35)			
Shipping weight	125 (57)			
Installed, with refrigerant	79 (36)			
Number of Fans	2	2	2	2
Air flow, Nominal, ft <sup>3</sup> / min (m <sup>3</sup> / hr)	1000 (1699) with rear inlet. Bottom inlet air flow may be less, depending on restrictions inside cabinet		833 (1415) with rear inlet. Bottom inlet air flow may be less, depending on restrictions inside cabinet	
Audible noise	78 dBa sound power		73 dBa sound power	
Pipe Connections (without Liebert Flex Pipe)				
Refrigerant Supply from Liebert XDP/Liebert XDC	1/2" OD Cu, (optional 1/2" threaded coupler flex piping)			
Refrigerant Return to Liebert XDP/Liebert XDC	5/8" OD Cu, (optional 3/4" threaded coupler flex piping)			
Serviceable Parts	Fans and electrical components			
Cabinet Exterior Finish	Black, matte finish, heat-fused powder coat			
Options				
Smart Module control board (factory-installed)	Dry contact, 24VAC, 1A maximum			
Pre-Charged Refrigerant	R-134a refrigerant, one-shot connections			
Agency				
Approvals	CSA 60Hz		CSA 50Hz	CE 50Hz
*Refer to Figure 9.5 on page 193 for complete part number.				

**Table 9.11 Liebert XDV10 specifications**

Models	XDV10BK*	XDV10BT*	XDV10BS*	
	XDV10SK*	XDV10ST*	XDV10SS*	
	60 Hz	60 Hz	50 Hz	50 Hz
Cooling Capacity	Nominal (98°F [37°C] EAT): 10kW / 2.8 Tons Maximum (106°F [41°C] EAT): 11.7kW/3.3 Tons		Nominal (98°F [37°C] EAT): 8.3kW / 2.4 Tons Maximum (116°F [47°C] EAT): 11.7kW/3.3 Tons	
Conditions	Capacity Rating is @ 55°F (13°C) Entering Fluid Temperature and 50°F (10°C) or lower dew point, rear air inlet.			
Electrical Requirements				
Input	120V model: 1ph-60 Hz	230V model: 1ph-60 Hz	230V model: 1ph-50 Hz	
Input power connections	2 power connections, each model			
Full Load Amps	120V model: 2.0A	230V model: 1.0A		

**Table 9.11 Liebert XDV10 specifications (continued)**

Models	XDV10BK*	XDV10BT*		XDV10BS*
	XDV10SK*	XDV10ST*		XDV10SS*
	60 Hz	60 Hz	50 Hz	50 Hz
Power consumption, nominal, watts	180	190	190	190
Dimensions, in. (mm)				
Height – module only	14 (355) not including pipe connections			
Height – including hard pipe connections	18-5/8 (473)			
Height – including one-shot connections	19-5/8 (498)			
Width	22-7/8 (581)			
Depth – Top	39-1/2 (1003)			
Depth – Bottom	29-5/8 (752)			
Weight, lb (kg)				
Module only	77 (35)			
Shipping weight	125 (57)			
Installed, with refrigerant	79 (36)			
Number of fans	2	2	2	2
Airflow, Nominal, ft <sup>3</sup> / min (m <sup>3</sup> / hr)	1000 (1699) with rear inlet. Bottom inlet airflow may be less, depending on restrictions inside cabinet		833 (1415) with rear inlet. Bottom inlet airflow may be less, depending on restrictions inside cabinet	
Audible noise	78 dBA sound power		73 dBA sound power	
Pipe Connections (without Liebert Flex Pipe)				
Refrigerant supply from Liebert XDP/ XDC	1/2" OD, Cu, (optional 1/2" threaded coupler flex piping)			
Refrigerant return to Liebert XDP/ XDC	5/8" OD, Cu, (optional 3/4" threaded coupler flex piping)			
Serviceable Parts	Fans and electrical components			
Cabinet Exterior Finish	Black, matte finish, heat-fused powder coat			
Options				
Smart Module control board (factory-installed)	Dry contact, 24VAC, 1A maximum			
Pre-Charged Refrigerant	R-134a refrigerant, one-shot connections			
Agency				
Approvals	CSA 60Hz		CSA 50Hz	CE 50Hz
*Refer to Figure 9.5 on the facing page for complete part number.				

**Table 9.12 Liebert XDV dimensions—domestic and export**

Model	Shipping Dimensions Length x Width x Height inches (mm)		Module Dimensions Unpacked Length x Width x Height inches (mm)
	Domestic	Export	Module Only
All Models	48 x 40 x 24-1/4 (1219 x 1016 x 616)	45-4/5 x 30-3/4 x 33 (1163 x 781 x 839mm)	39-1/2 x 22-7/8 x 14 (1003 x 581 x 356)

**Figure 9.5 Liebert XDV model number nomenclature**

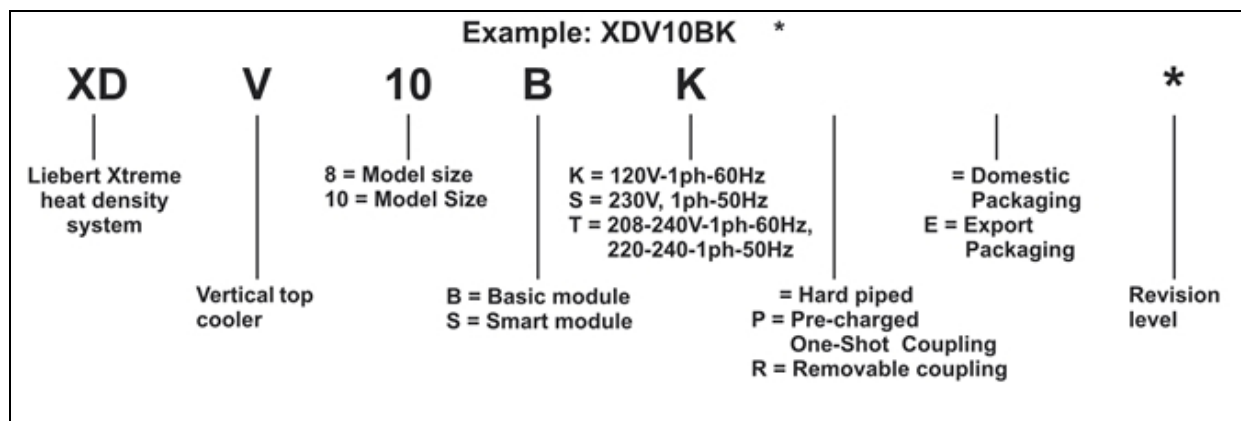

**Table 9.13 Liebert XDC160 specifications**

Models	XDC160 Air		XDC160 Water / Glycol
	XDC160AA	XDC160AM	189192G3 (90-100°F) 189192G5 (65-85°F)
Cooling Capacity, tons (kW)	46 (160)	37 (130)	See Table 9.14 on page 195, Table 9.15 on page 195 and Table 9.16 on page 196 for Water/Glycol performance data
Minimum Load	40% of system nominal capacity (64 kW for 60Hz unit)		
Electrical Requirements			
Input	460V-3ph-60Hz	380/415V-3ph-50Hz	460V-3ph-60Hz
Full Load Amps	79A		
Minimum supply wire sizing ampacity	84A		
Maximum fuse or circuit breaker size	100A		
Dimensions, inches (mm)			
Height - Main unit only	78 (1981)		
Height - Main unit only, as shipped	83 (2108)		
Width - Main unit	74 (1879)		
Depth - Main unit	34-5/8 (879)		

**Table 9.13 Liebert XDC160 specifications (continued)**

Models	XDC160 Air		XDC160 Water / Glycol
	XDC160AA	XDC160AM	189192G3 (90-100°F) 189192G5 (65-85°F)
Height - Water/Glycol-Cooled Condenser Stand	N/A		24 (607)
Width - Water/Glycol-Cooled Condenser Stand	N/A		72 (1829)
Depth - Water/Glycol-Cooled Condenser Stand	N/A		33 (839)
Weight, lb (kg)			
Main unit only	1800 (817)		
Main unit only, as shipped	Domestic: 1945 (882); Export: 2093 (949)		
Water/Glycol-Cooled Condenser Stand	N/A		1075 (488)
Water/Glycol-Cooled Condenser Stand, as shipped	N/A		1150 (521)
Pipe Connections, inches, O.D., Cu			
Liebert XD Coolant supply to Liebert XD cooling modules	1-1/8		
Liebert XD Coolant return from Liebert XD cooling modules	2-1/8		
Liquid line, DX circuit	7/8		
Hot gas line, DX circuit	1-3/8		
Heat Rejection Equipment			
95°F (35°C) ambient air-cooled condenser	2-DCSL415		N/A
105°F (41°C) ambient air-cooled condenser	2-DCSL616		N/A
Number of Liebert XD Cooling Modules Connected, Maximum (Minimum)			
Liebert XDCF10	16 (6)		
Liebert XDH20	8 (4)		
Liebert XDH32	5 (2)		
Liebert XDO16	10 (4)		
Liebert XDO20	8 (4)		
Liebert XDV8	20 (8)		
Liebert XDV10	16 (7)		
Cabinet Exterior Finish	Black, matte finish, heat-fused powder coat		
Maximum Ambient Operating Temperature °F (°C)	86 (30)		
Agency			
Approvals	CSA	CE	CSA



**Table 9.14 Floor stand specifications—water-cooled Liebert XDC**

	XDC160 Water Floor Stand - 60Hz				
	189192G5				189192G3
Entering Fluid Temp °F (°C)	65 (18)	70 (21)	75 (24)	85 (29)	95 (35)
Performance Data					
Cooling capacity, tons (kW)	46.1(162.3)	46.1(162.3)	46.1(162.3)	46.1(162.3)	44.5(156.5)
Flow, GPM	50	58	70	110	142
Pressure Drop, psi (Ft Water)	2.7 (6.2)	4.9 (11.3)	5.4 (12.5)	20.7 (47.8)	27.3 (63.1)
Heat Rejection Equipment					
Water regulating valve size	1"	1"	1"	1"	1"
Piping Connections					
Water / glycol supply and return lines	2-1/8"	2-1/8"	2-1/8"	2-1/8"	2-1/8"

**Table 9.15 Floor stand specifications—Liebert XDC with 40% propylene glycol**

	XDC160 Glycol Floor Stand - 60Hz - 40% PG		
	189192G3		
Outside Ambient °F (°C)	95 (35)	100 (38)	105 (41)
Max Entering Fluid Temp °F (°C)	110 (43)	110 (43)	110 (43)
Performance Data			
Cooling capacity, tons (kW)	42.5 (149.4)		
Total Heat Rejection, (kW)	192.6		
Flow, GPM	206		
Pressure Drop, psi (ft water)	37.2 (85.9)		
Heat Rejection Equipment			
Drycooler	DDNT 940A	2 x DDNT 880A*	
Drycooler Pressure Drop, psi (ft water)	6.7 (15.8)	2.9 (6.6)	
Glycol pump package - 10hp	460V - D10ANTS1317; 208V - D10YNTS1317		
Pump Control Package - 208V	RP020HY04S0758		
Pump Control Package - 460V	RP020HA08S0758		
Pump Total Head @ 206 GPM, ft water	145		
Water regulating valve size	1-1/4"		
Piping Connections			
Water / glycol supply and return lines	2-5/8"		
*When multiple drycoolers are used, ensure flow is balanced.			

**Table 9.16 Floor stand specifications—Liebert XDC with 40% ethylene glycol**

XDC160 Glycol Floor Stand - 60Hz - 40% EG 189192G3			
Outside Ambient °F (°C)	95 (35)	100 (38)	105 (41)
Max Entering Fluid Temp °F (°C)	110 (43)	110 (43)	110 (43)
Performance Data			
Cooling capacity, tons (kW)	42.5 (149.4)		
Total Heat Rejection, (kW)	192.6		
Flow, GPM	204		
Pressure Drop, psi (ft water)	35.9 (82.9)		
Heat Rejection Equipment			
Drycooler	DDNT 940A	2 x DDNT 880A*	
Drycooler Pressure Drop, psi (ft water)	6.5 (15.1)	2.7 (6.3)	
Glycol pump package - 10HP	460V - D10ANTS1317; 208V - D10YNTS1317		
Pump Control Package - 208V	RP020HY04S0758		
Pump Control Package - 460V	RP020HA08S0758		
Pump Total Head @ 204 GPM, ft water	145		
Water regulating valve size	1-1/4"		
Piping Connections			
Water / glycol supply and return lines	2-5/8"		
*When multiple drycoolers are used ensure flow is balanced.			

**Figure 9.6 Liebert XDC model number nomenclature**

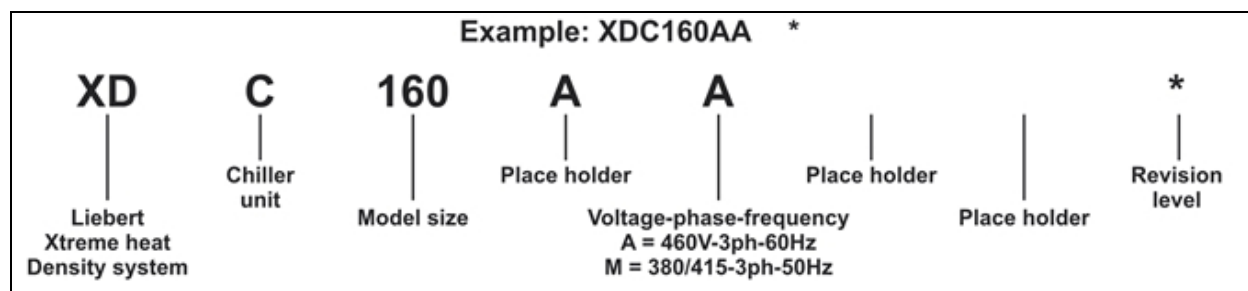

**Table 9.17 Liebert XDP160 specifications**

Models	XDP160RC--3	XDP160RA--3	XDP160RM--3
Cooling Capacity, Nominal	160kW / 46 Tons, 60Hz		140kW / 40 Tons, 50Hz
	Each capacity is based on 45°F (7°C) entering water temperature and 140gpm (530lpm) water flow rate. Capacity is reduced when glycol mixtures are used in place of 100% water.		
Minimum Load	30% of nominal system capacity or 48kW (163,800BTU/H)		
Electrical Requirements			
Input	208V/3ph/60Hz	460V/3/ph60Hz	380/415V/3ph/50Hz
Full Load Amps		2.1A	2.3A
Dimensions, inches (mm)			
Height – Unit only	78 (1981)		
Height – As shipped	83 (2108)		
Width	38 (965)		
Depth	34 (864)		
Weight, lb (kg)			
Unit only	821 (372)		
Shipping weight	Domestic: 990 (449); Export: 1067 (484)		
Installed, with refrigerant and chilled water	1038 (471)		
Pipe Connections			
Refrigerant supply to Liebert XD cooling module	1-1/8" OD, Cu		
Refrigerant return from Liebert XD cooling module	2-1/8" OD, Cu		
Chilled water supply and return	2-5/8" OD, Cu		
Control valve	2-way, 2" nominal; 35 PSIG close-off pressure rating; 150 PSIG maximum allowable pressure		
Pressure Drop – Chilled Water Side	20 psig (137kPa, 1.38bar), with 140 gpm (530lpm) water flow rate, control valve fully open		
Temperature Rise – Chilled Water Side at rated flow, °F (°C)	8.0 (4.4)	6.9 (3.8)	
Number of Liebert XD Cooling Modules Connected, Maximum (Minimum)			
Liebert XDCF10	16 (5)		
Liebert XDH20	8 (3)		
Liebert XDH32	5 (2)		
Liebert XDV8	20 (6)		
Liebert XDV10	16 (5)		
Liebert XDO16	10 (3)		
Liebert XDO20	8 (3)		
Cabinet Exterior Finish	Black, matte finish, heat-fused powder coat		
Operating Ambient Temperature, Maximum, °F (°C)	86 (30)		
Agency			
Approvals	CSA 60Hz		CE 50Hz

Figure 9.7 Liebert XDP model number nomenclature

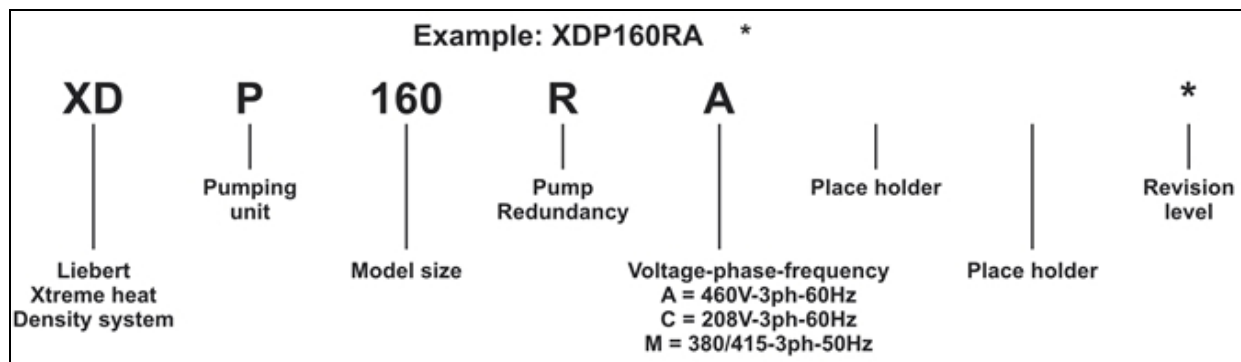





---

VertivCo.com | Vertiv Headquarters, 1050 Dearborn Drive, Columbus, OH, 43085, USA

© 2017 Vertiv Co. All rights reserved. Vertiv and the Vertiv logo are trademarks or registered trademarks of Vertiv Co. All other names and logos referred to are trade names, trademarks or registered trademarks of their respective owners. While every precaution has been taken to ensure accuracy and completeness herein, Vertiv Co. assumes no responsibility, and disclaims all liability, for damages resulting from use of this information or for any errors or omissions. Specifications are subject to change without notice.

SL-16655\_REV13\_11-17/590-1704-501A