



**Liebert®**

EconoPhase™

Installer/User Guide

14 to 72 Ton (50 to 250 kW) Capacity, 50 and 60 Hz

The information contained in this document is subject to change without notice and may not be suitable for all applications. While every precaution has been taken to ensure the accuracy and completeness of this document, Vertiv assumes no responsibility and disclaims all liability for damages resulting from use of this information or for any errors or omissions. Refer to other local practices or building codes as applicable for the correct methods, tools, and materials to be used in performing procedures not specifically described in this document.

The products covered by this instruction manual are manufactured and/or sold by Vertiv. This document is the property of Vertiv and contains confidential and proprietary information owned by Vertiv. Any copying, use or disclosure of it without the written permission of Vertiv is strictly prohibited.

Names of companies and products are trademarks or registered trademarks of the respective companies. Any questions regarding

### **Technical Support Site**

If you encounter any installation or operational issues with your product, check the pertinent section of this manual to see if the issue can be resolved by following outlined procedures. Visit <https://www.Vertiv.com/en-us/support/> for additional assistance.

# TABLE OF CONTENTS

<b>1 Important Safety Instructions</b> .....	<b>1</b>
<b>2 Model Number Nomenclature</b> .....	<b>5</b>
2.1 Model-number Nomenclature Detail .....	5
<b>3 EconoPhase Pumped-refrigerant Economizer with a Liebert DSE™ System</b> .....	<b>9</b>
3.1 Overview of Operating Modes .....	10
3.2 EconoPhase Operation .....	12
3.2.1 EconoPhase Control .....	13
3.2.2 Pump Start-up Routine .....	16
3.2.3 Switch from Compressor Operation to Pump Operation .....	16
3.2.4 Switch from Pump Operation to Compressor Operation .....	16
3.2.5 Loop Temperatures .....	17
<b>4 Pre-installation Preparation and Guidelines</b> .....	<b>19</b>
4.1 Standard Air-cooled Systems versus Liebert EconoPhase Systems .....	19
4.2 Determine Cooling Requirements of the System .....	20
4.3 Mechanical Considerations .....	20
4.4 Planning Dimensions .....	20
4.5 EconoPhase Unit Weights .....	21
<b>5 Equipment Handling</b> .....	<b>23</b>
5.1 Unpacking and Moving the EconoPhase Unit .....	23
<b>6 Piping and Refrigerant Requirements</b> .....	<b>27</b>
6.1 Placement Options and Piping Restrictions for the EconoPhase Unit and Liebert MC Condenser .....	28
6.2 Refrigerant Line Sizing in an EconoPhase System .....	28
6.2.1 Refrigerant Charge for EconoPhase Systems .....	29
<b>7 Electrical Connections</b> .....	<b>31</b>
7.1 High-voltage Electrical Connections .....	32
7.2 Low-voltage, Communication Wiring Connections .....	32
<b>8 Troubleshooting</b> .....	<b>35</b>
<b>Appendices</b> .....	<b>39</b>
Appendix A: Technical Support and Contacts .....	39
Appendix B: Submittal Drawings .....	41

This page intentionally left blank

# 1 IMPORTANT SAFETY INSTRUCTIONS

## SAVE THESE INSTRUCTIONS

This manual contains important safety instructions that should be followed during the installation and maintenance of the Liebert® EconoPhase. Read this manual thoroughly before attempting to install or operate this unit.

Only qualified personnel should move, install or service this equipment.

Adhere to all warnings, cautions, notices and installation, operating and safety instructions on the unit and in this manual. Follow all installation, operation and maintenance instructions and all applicable national and local building, electrical and plumbing codes.



**WARNING! Arc flash and electric shock hazard. Open all local and remote electric power disconnect switches, verify with a voltmeter that power is Off and wear personal protective equipment (PPE) per NFPA 70E before working within the electric control enclosure. Failure to comply can cause serious injury or death. Customer must provide earth ground to unit, per NEC, CEC and local codes, as applicable. Before proceeding with installation, read all instructions, verify that all the parts are included and check the nameplate to be sure the voltage matches available utility power. Refer to unit electrical schematic. Follow all local codes.**

Reinstall all terminal covers before connecting power to the unit. Failure to install these covers exposes high-voltage terminals.



**WARNING! Risk of electric shock from leakage current. Can cause injury or death. Reconnect earth ground if servicing or replacing the variable speed drive (VSD).**



**WARNING! Risk of over-pressurization of the refrigeration system. Can cause explosive discharge of high-pressure refrigerant, loss of refrigerant, environmental pollution, equipment damage, injury, or death. This unit contains fluids and gases under high pressure. Use extreme caution when charging the refrigerant system. Do not pressurize the system higher than the design pressure marked on the unit's nameplate. For systems requiring EU CE compliance (50 Hz), the system installer must provide and install a pressure relief valve in the high side refrigerant circuit that is rated same as the refrigerant high side "Max Allowable Pressure" rating that is marked on the unit serial tag. The pressure relief valve must be CE-certified to the EU Pressure Equipment Directive by an EU "Notified Body."**



**WARNING!** Risk of improper wiring, piping, moving, lifting and handling. Can cause equipment damage, serious injury or death. Installation and service of this equipment should be done only by qualified personnel who have been specially-trained in the installation of air-conditioning equipment and who are wearing appropriate, OSHA-approved PPE.



**CAUTION:** Risk of handling heavy unit and component parts. Can cause injury and equipment damage. Use OSHA-recommended safe lifting techniques and/or lifting equipment rated for the weight of the unit.

See [Typical EconoPhase unit weights](#) on page 21, for unit weight.



**CAUTION:** Risk of contact with sharp edges, splinters, and exposed fasteners. Can cause injury. Only properly trained and qualified personnel wearing appropriate, OSHA-approved PPE should attempt to move, lift, remove packaging from or prepare the unit for installation.



**CAUTION:** Risk of contact with hot surfaces. Can cause injury. The refrigerant discharge lines, pump motor, and some electrical components are extremely hot during unit operation. Allow sufficient time for them to cool to a touch-safe temperature before working within the unit cabinet. Use extreme caution and wear appropriate, OSHA-approved PPE when working on or near hot components.



**CAUTION:** Risk of electric shock and short circuits. Can cause equipment damage, injury or death. Insert CSA certified or UL listed bushings into holes and or knockouts used to route wiring through to protect the wire insulation from contact with sheet metal edges.

## NOTICE

Risk of excessive oxidation and scale formation on interior piping surfaces. Can cause equipment damage.

During brazing, the refrigerant lines must be filled with flowing dry nitrogen to prevent excessive oxidation and scale formation inside the piping. Use currently documented and accepted good refrigeration practices for piping supports, leak testing, dehydration and charging. Failure to use good system practices may result in damage to the system. Refer to the most currently published ASHRAE refrigeration handbook for documented good practice refrigeration piping guidelines.

## NOTICE

Risk of improper electrical connection of three-phase input power. Can cause unit damage.

Service technicians should use a gauge set during the initial start-up to verify that the three-phase power is connected properly.

**NOTICE**

Risk of overheated terminals. Can cause wiring and component damage.

Use copper wiring only. Make sure that all connections are tight.

**NOTICE**

Risk of improper program adjustment. Can cause equipment damage and loss of warranty.

The VSD is factory-programmed for proper operation. Altering the VSD program without authorization from the factory may void the warranty.

**NOTICE**

Risk of mismatched input power supply and VSD requirements. May cause equipment damage and failure.

The EMC filter must be removed from the VSD if the power supply is Delta-connected.

**NOTICE**

Risk of damage from forklift. Can cause unit damage. Keep tines of the forklift level and at a height suitable to fit below the skid and/or unit to prevent exterior and/or underside damage.

This page intentionally left blank



## 2 MODEL NUMBER NOMENCLATURE

This section describes the model-number configuration for Liebert® EconoPhase units and components.

### 2.1 Model-number Nomenclature Detail

[EconoPhase Model-number Digit Definitions](#) below describes each digit of the model number.

**Table 2.1 Liebert EconoPhase Model Number Example**

1	2	3	4	5	6	7	8	9	10	11	12
P	R	1	2	5	A	A	6	D	D	—	*

**Table 2.2 EconoPhase Model-number Digit Definitions**

Digit	Description
Digits 1 to 2 - Product Family	PR = Liebert® Pumped Refrigerant Economizer System
Digits 3 to 5 - Nominal Sensible Capacity, kW	050 085 125 250
Digit 6 - Air Discharge	A = Air-cooled heat rejection
Digit 7 - Power Supply	A = 460-3-60 B = 575-3-60 G = 415-3-50 Y = 208/230-3-60 2 = 380-3-60
Digit 8 - Disconnect Switch, Amperage	5 = 5,000 Amp SCCR 6 = 65,000 Amp SCCR

**Table 2.2 EconoPhase Model-number Digit Definitions (continued)**

Digit	Description
Digit 9 - Pump Configuration S = Single D = Dual	
Digit 10 - Packaging D = Domestic E = Export Crating	
Digit 11 - Pump Design — = Standard Pump H = High Efficiency Pump 2 = High Flow Pump	
Digit 12 - Revision 0 = No SFAs (Any Numeric or Alpha letter except S) S = SFA	

**Table 2.3 EconoPhase Specifications and Electrical Power Requirements**

Digits				Volts	Phase	Hertz	FLA	Minimum Supply-circuit Ampacity	Max Fuse Size	Single Pump Motor (one pump per circuit)	
1-5	7	9	11							HP	FLA
Product Family	Power Supply	Pump Configuration	Pump Design								
PR050	A	S	-	460	3	60	3.5	4.4	15	1.6	3.5
PR050	Y	S	-	208/230	3	60	6.9	8.6	15	1.6	6.9
PR050	B	S	-	575	3	60	2.8	3.5	15	1.6	3.5
PR050	2	S	-	380	3	60	4.2	5.3	15	1.6	4.2
PR050	G	3	-	415	3	50	3.7	4.7	15	1.2	3.7
PR050	A	S	H	460	3	60	1.3	1.6	15	0.75	1.3
PR050	Y	S	H	208/230	3	60	2.6	3.3	15	0.75	2.6
PR050	B	S	H	575	3	60	1	1.3	15	0.75	1.3
PR050	2	S	H	380	3	60	1.6	2	15	0.75	1.6
PR050	G	S	H	415	3	50	1.2	1.5	15	0.75	1.2
PR085	A	D	-	460	3	60	7	7.9	15	1.6	3.5
PR085	Y	D	-	208/230	3	60	13.8	15.5	20	1.6	6.9

**Table 2.3 EconoPhase Specifications and Electrical Power Requirements (continued)**

Digits				Volts	Phase	Hertz	FLA	Minimum Supply-circuit Ampacity	Max Fuse Size	Single Pump Motor (one pump per circuit)	
1-5	7	9	11							HP	FLA
Product Family	Power Supply	Pump Configuration	Pump Design								
PR085	B	D	-	575	3	60	5.6	6.3	15	1.6	3.5
PR085	2	D	-	380	3	60	8.4	9.4	15	1.6	4.2
PR085	G	D	-	415	3	50	7.4	8.3	15	1.2	3.7
PR085	A	D	H	460	3	60	2.6	2.9	15	0.75	1.3
PR085	Y	D	H	208/230	3	60	5.2	5.9	15	0.75	2.6
PR085	B	D	H	575	3	60	2	2.3	15	0.75	1.3
PR085	2	D	H	380	3	60	3.2	3.6	15	0.75	1.6
PR085	G	D	H	415	3	50	2.4	2.7	15	0.75	1.2
PR125	A	D	-	460	3	60	7	7.9	15	1.6	3.5
PR125	Y	D	-	208/230	3	60	13.8	15.5	20	1.6	6.9
PR125	B	D	-	575	3	60	5.6	6.3	15	1.6	3.5
PR125	2	D	-	380	3	60	8.4	9.4	15	1.6	4.2
PR125	G	D	-	415	3	50	7.4	8.3	15	1.2	3.7
PR250	A	D	- or 2	460	3	60	7	7.9	15	1.6	3.5
PR250	Y	D	- or 2	208/230	3	60	13.8	15.5	20	1.6	6.9
PR250	B	D	- or 2	575	3	60	5.6	6.3	15	1.6	3.5
PR250	2	D	- or 2	380	3	60	8.4	9.4	15	1.6	4.2
PR250	G	D	- or 2	415	3	50	7.4	8.3	15	1.2	3.7

Source DPN002327 Rev. 11 and DPN004355 Rev. 2

This page intentionally left blank

## 3 ECONOPHASE PUMPED-REFRIGERANT ECONOMIZER WITH A LIEBERT DSE™ SYSTEM

Liebert® DSE systems are designed to provide precision air conditioning to computer racks in a data center or computer room as efficiently and effectively as possible.

A Liebert® DSE system with EconoPhase is composed of individually-shipped components or components assembled together on skids. Some examples are:

### System example 1

- Liebert® DSE—High efficiency, floor-mounted indoor unit
- Liebert® MC™ Condenser—Air-cooled microchannel condenser, premium version
- Liebert® EconoPhase™—Liebert® EconoPhase pumped-refrigerant economizer (PRE)

### System example 2

- Liebert® DSE—High efficiency, floor-mounted indoor unit
- Liebert® MCV Heat-rejection Skid—Air-cooled microchannel condenser, premium version with a Liebert® EconoPhase pumped-refrigerant economizer (PRE)

The EconoPhase PRE is an add-on module for use with an air-cooled DSE system. The EconoPhase allows the system to switch to EconoPhase operation when the outdoor temperature is low enough to provide the required temperature difference between the inside air and the outside air, which, in turn, provides significant energy savings because the compressor(s) do not operate. At lower temperatures, the system switches one or both circuits from Compressor Mode to Pump Mode. The pump consumes roughly one-tenth of the power consumed by the compressor.

The EconoPhase system maintains this energy efficiency by employing the heat absorption properties of a liquid (pumped refrigerant) through a phase change. Refrigerant is pumped as a liquid, becomes a gas within the DSE evaporator and is then returned to the condenser where it condenses to a liquid. The sub-cooled liquid refrigerant from the condenser is run directly into the EconoPhase pumps and circulates back to the DSE unit (see [EconoPhase pumped-refrigerant pressure enthalpy diagram](#) on the next page). The system operates as a typical air-cooled direct-expansion system when outdoor ambient conditions are unfavorable to EconoPhase operation. The pumps in the EconoPhase PRE are turned off and bypassed during compressor operation.

Figure 3.1 EconoPhase pumped-refrigerant pressure enthalpy diagram

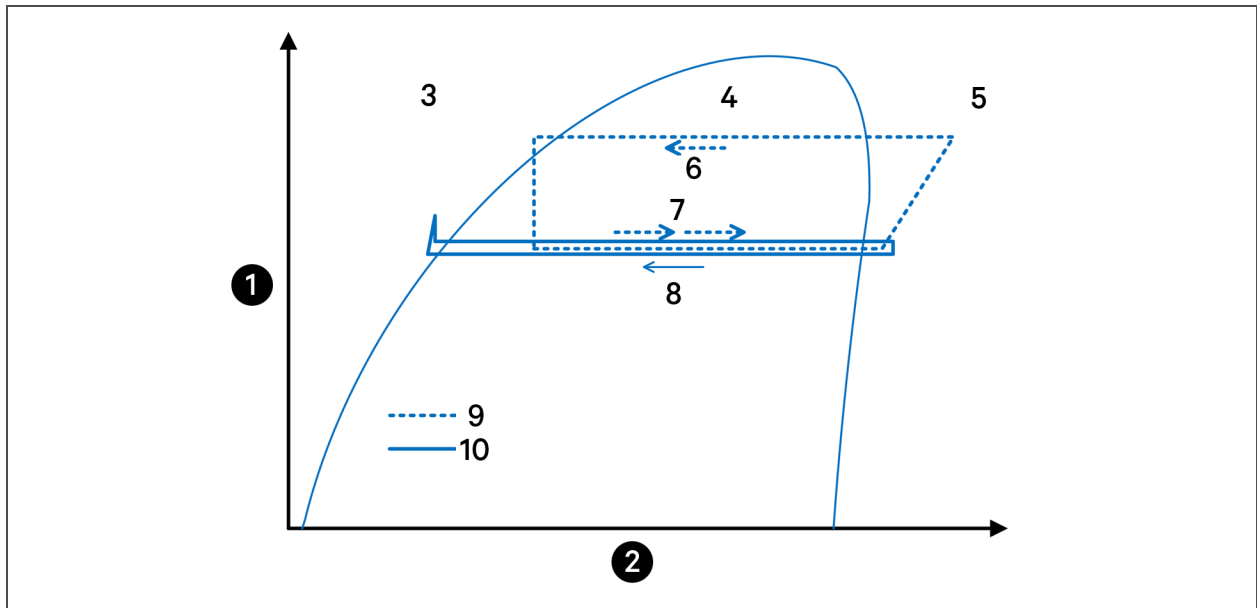

Item	Description	Item	Description
1	Pressure	6	Condenser (DX mode)
2	Enthalpy	7	Indoor unit
3	Liquid	8	Condenser (pump mode)
4	Liquid/Vapor maximum	9	Traditional vapor-compression cycle
5	Vapor	10	EconoPhase cycle

### 3.1 Overview of Operating Modes

Each circuit on a system combining a Liebert® EconoPhase, Liebert® DSE and Liebert® MC condenser has 6 distinct operating modes:

- Idling with compressor and pumps Off
- Start up
- Compressor operation
- Compressor-to-pump changeover
- Pump operation
- Pump-to-compressor changeover

A circuit will run most of the time in either compressor or pump operation mode. These modes both efficiently remove heat from the conditioned space and reject it via the air-cooled condenser. The flow paths during each mode of operation are detailed in [Compressorized operation flow path](#) below and [Pump operation flow path](#) on the next page.

A couple of differences to note between Compressor Mode and EconoPhase operation:

- The unit does not dehumidify in EconoPhase operation. If dehumidification is desired, EconoPhase operation must be disabled.
- Bubbles may be seen in the site glass in the indoor unit when the system is in EconoPhase operation. This does not necessarily mean the system is low on charge. Refer to the Liebert® DSE™ user manual (available at [www.Vertiv.com](http://www.Vertiv.com)) for complete charging instructions for the DSE/EconoPhase system.

**Figure 3.2 Compressorized operation flow path**

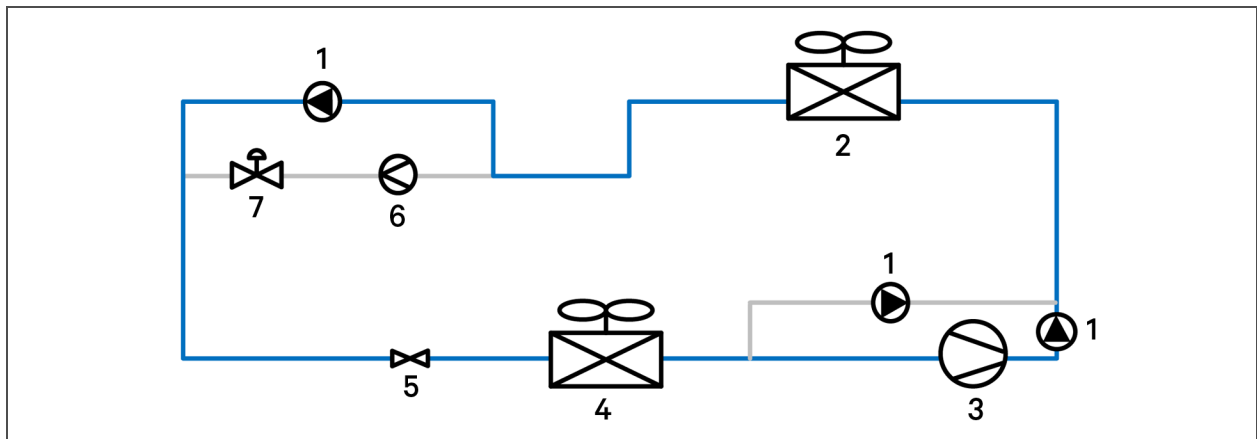

Item	Description	Item	Description
1	Check valve	5	Electronic expansion valve (EEV)
2	Condenser	6	Pump
3	Compressor	7	Solenoid valve
4	Evaporator		

Figure 3.3 Pump operation flow path

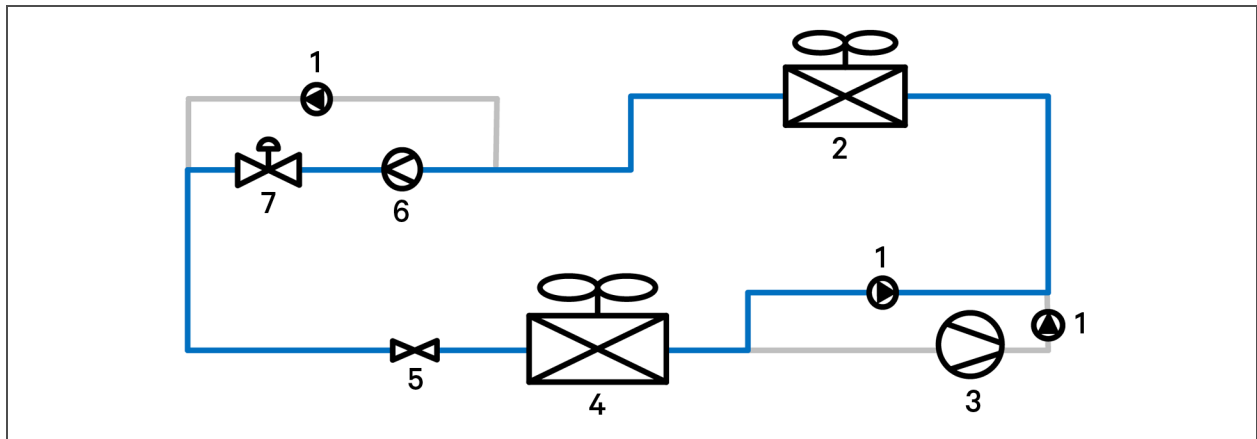

Item	Description	Item	Description
1	Check valve	5	Electronic expansion valve (EEV)
2	Condenser	6	Pump
3	Compressor	7	Solenoid valve
4	Evaporator		

### 3.2 EconoPhase Operation

The EconoPhase unit enables the Liebert® DSE™ system to operate in any of 3 modes to control temperature, depending on the outdoor temperature and the load.

- Compressor Mode
- Pump Mode
- Mixed Mode



When the outdoor temperature becomes low enough to provide the required temperature difference between the inside air and the outside air, there is no need to compress the refrigerant to a higher pressure/temperature. When the outdoor temperature is low enough, the system switches from Compressor Mode to Pump Mode or to Mixed Mode.

- **Compressor Mode:** All available compressors may be used to maintain the control temperature. All the available EconoPhase pumps are Off. The control will typically run in this mode when the load and temperatures are such that full or partial EconoPhase operation is not possible, or because certain pumps have experienced alarms.
- **Pump Mode:** All of the available pumps may be used to maintain the Control Temperature. All the compressors in the system are Off. The control will typically run in this mode when load and temperatures permit.
- **Mixed Mode** (Dual-pump models only): The pump in Circuit 1 is On and the compressor(s) in Circuit 2 is On. Some systems may not have Mixed Mode capability, depending on the manufacture date. Contact the factory to inquire about a software upgrade.

### 3.2.1 EconoPhase Control

EconoPhase operation has three main controlled parameters:

- room temperature
- refrigerant temperature
- pump pressure differential (outlet pressure - inlet pressure)

#### Room Temperature

When the system is in Pump Mode, the room temperature is controlled by modulating the pump speed with a variable frequency drive. The load requirement will determine if one pump or two are needed. [Two-circuit pump control](#) on the next page, shows the sequence of operation in terms of pump speed.

Minimum speed is 45% and maximum speed is 100%. See [Events and Actions of 2-circuit pump control](#) on the next page, for more detail on the events depicted and the conditions that trigger action.

The pump start-up routine calls for a start speed of 80% (see [Pump Start-up Routine](#) on page 16 for more detail). The pump will run for up to 60 seconds at 80% with the EEV at 60% while waiting on the pump differential to reach at least 12 psid to indicate that flow has been established. If the pump establishes flow, the speed will change from 80% to the required control speed as shown on the curves in [Two-circuit pump control](#) on the next page.



As seen in the last row of [Events and Actions of 2-circuit pump control](#) on the previous page, an exception to the “F to G” event, in which Pump 2 starts if Pump 1 is at its maximum speed for 60 seconds and Delta T (Room Air Temperature - Setpoint) is  $> 1^{\circ}\text{F}$ , is that Pump 2 will start when Delta T  $> 2^{\circ}\text{F}$  even if Pump 1 is not at its maximum speed. In that event, Pump 2 starts via the start-up routine and then goes immediately to its minimum position.

In the case of a transition from Compressor Mode to Pump Mode, the pumps will be given initial speeds based on the call for cooling at the time of transition. The pumps will go to this initial speed after the start-up routine is completed. This will mean that, depending on the load, both pumps will start immediately at the transition to Pump Mode from Compressor Mode.

When the system is in Mixed Mode, the room temperature is controlled either by modulating the digital compressor(s) on Circuit 2 with the pump on Circuit 1 at 100%, or by modulating the pump speed on Circuit 1 with the compressor(s) operating at the minimum digital percent.

### **Refrigerant Temperature**

When a circuit is running in Pump Mode, the refrigerant temperature is controlled by the condenser fan speed. When a circuit switches from Compressor Mode to Pump Mode, the condenser fan speed control changes from pressure control to temperature control, with the controlled parameter being condenser outlet refrigerant temperature.

The default setpoint on Circuit 1 is  $45^{\circ}\text{F}$ , while on Circuit 2 it is  $37^{\circ}\text{F}$ . The condenser fan speed will modulate to provide the respective temperature. But if the outdoor temperature is warm enough, or if the load is high enough, the fans might be at 100% and the actual refrigerant temperature might be above the setpoint. In that case, the temperature will depend on the heat rejection capability of the condenser at the given conditions.

Actual fan speed will depend on the load and the outdoor temperature. The fan speed will be lower for a given heat load with lower outdoor temperature in order to maintain the setpoint.

Because the refrigerant temperature could be below the dew point inside, the indoor piping must be insulated to prevent condensation. In addition, the outdoor piping must be insulated so that heat is not lost to the outdoor air at very low ambient temperatures, causing the refrigerant temperature to fall and increasing the possibility of frost at the evaporator.

### **Pump Pressure Differential**

The pump pressure differential must to be maintained above a minimum for cooling and lubricating flow to be provided to the pump motor and bearings. The differential is controlled by EEV position. When the system switches to EconoPhase operation, the EEV control changes from superheat control to manual control. The Liebert® iCOM™ controller then signals the EEV to control its position based on pump differential, unless during pump mode operation, the suction superheat drops below the minimum acceptable level, then the EEV will begin to close and restrict refrigerant mass flow to build superheat.

The default minimum EEV position is 50% and the maximum is 80%. The pump differential setpoint is 20 psid. If the pump is running at a high speed at steady state, the EEV may be at 80% and the actual pump differential may be above 25 psid. In that case, the EEV will stay at 80% and the differential will just be a function of pump speed and system pressure drop.

If the pump differential drops below 5 psid continuously for 30 minutes, the system will switch to direct expansion mode for 30 minutes. The system will switch back to EconoPhase operation if the conditions are still compatible.

### 3.2.2 Pump Start-up Routine

When either pump attempts to start, the first attempt will be at 80% speed. If flow is not established (as detected by pump differential being at least 12 psid within 60 seconds), the pump will turn Off for 10 seconds before trying again at 90% speed. If flow is still not established, the pump will turn Off for 10 seconds before trying again at 100% speed. If flow is not established after the 100% speed attempt, the system will switch to DX mode for 10 minutes before attempting to start the pumps again if the conditions are still compatible.

The second start-up routine is the same as above. If the second start-up attempt is unsuccessful, the system will switch to DX mode for 60 minutes before trying again.

The third start-up routine will be the same as above. If the third start-up attempt is unsuccessful, a “Pump Startup Fail” alarm will be displayed and EconoPhase operation will be locked out until the user manually resets the event at the Liebert® iCOM™.

### 3.2.3 Switch from Compressor Operation to Pump Operation

The Liebert® iCOM™ runs the system in the most efficient operating mode, given the load and temperature conditions. If Mixed Mode is available, the system will change from Compressor Mode to Mixed Mode when partial EconoPhase operation is possible and from Compressor or Mixed Mode to Pump Mode when full EconoPhase operation is possible

### 3.2.4 Switch from Pump Operation to Compressor Operation

The unit will switch from Pump Mode to Mixed Mode or Compressor Mode when at least one of the following is true:

- The difference between the actual controlled air temperature and the setpoint is 75% into the Cooling Proportional Band for 5 minutes. The default is 75%, but the percentage can be changed at the Liebert® iCOM™.

**NOTE: At start-up and at switchover from compressor operation to pump operation, more time is allowed to bring the temperature under control, but the temperature will never be allowed to go outside the cooling proportional band.**

- The pump differential pressure is below 5 psid for 30 minutes.
- The refrigerant temperature leaving the pump is below 30°F for 60 minutes.

- The pump does not establish flow at a pump start-up attempt.
- Power is lost at the EconoPhase unit.

### 3.2.5 Loop Temperatures

The EconoPhase page on the Liebert® iCOM™ display shows **Dis Ref Temp** (pump outlet temperature) and **Suct Ref Temp** (evaporator outlet temperature).

While the outdoor loop temperature could be close to the same on both circuits, the indoor loop temperatures (in most cases) and pressures in Circuit 1 will be higher than in Circuit 2 because of the staged cooling evaporator design in the Liebert® DA125. The **Suct Ref Temp** will be a function of load, return air temperature and pump speed.

[Representative EconoPhase loop temperatures at 35°F \(1.6°C\) outdoor temperature](#) below, shows some representative loop temperatures for EconoPhase at the outdoor rating condition, 35°F (1.6°C), for several heat load conditions and two return air conditions. System pressure drop for a given application will affect these temperatures because of its impact on flow rates for a given pump speed.

**NOTE:** The data in [Representative EconoPhase loop temperatures at 35°F \(1.6°C\) outdoor temperature](#) below, is from a system tested in controlled conditions and is for reference only.

**Table 3.2 Representative EconoPhase loop temperatures at 35°F (1.6°C) outdoor temperature**

Load, %	Outdoor Temp., °F (C)	RA Temp., °F (C)	Circuit 1	Circuit 2	Circuit 1	Circuit 2	Circuit 1	Circuit 2	Circuit 1	Circuit 2	Circuit 1	Circuit 2
			Pump Speed, %		Dis Ref Temp., °F (C)		Suct Ref Temp., °F (C)		Suction SH, °F (C)		Evap Saturation Temp., °F (C)	
100	35 (1.6)	85 (29.4)	100	60	52 (11.1)	40 (4.4)	82 (27.7)	68 (20)	21.9 (12.2)	22.6 (12.6)	59.9 (15.5)	45.4 (7.4)
75	35 (1.6)	85 (29.4)	100	46	52 (11.1)	37 (2.7)	78 (25.5)	69 (20.5)	18.2 (10.1)	28 (15.6)	60 (15.5)	40.5 (4.7)
50	35 (1.6)	85 (29.4)	64	45	46 (7.7)	37 (2.7)	84 (28.8)	75 (23.8)	32.8 (18.2)	35.7 (19.8)	51.3 (10.7)	39.6 (4.2)
25	35 (1.6)	85 (29.4)	54	Off	41 (5)	NA	84 (28.8)	NA	38.7 (21.5)	NA	45.5 (7.5)	NA
100	35 (1.6)	75 (23.8)	100	55	50 (10)	37 (2.7)	58 (14.4)	61 (16.1)	2.4 (1.3)	19.1 (10.6)	55 (13)	41.8 (5.4)
75	35 (1.6)	75 (23.8)	100	45	51 (10.5)	38 (3.3)	57 (13.8)	64 (17.7)	1.5 (0.8)	22.9 (12.7)	55.5 (13.3)	40.6 (4.7)
50	35 (1.6)	75 (23.8)	69	Off	46 (7.7)	NA	73 (22.7)	NA	21.1 (11.7)	NA	52.1 (11.2)	NA
25	35 (1.6)	75 (23.8)	54	Off	41 (5)	NA	74 (23.3)	NA	29.3 (16.3)	NA	45.1 (7.3)	NA

This page intentionally left blank

## 4 PRE-INSTALLATION PREPARATION AND GUIDELINES

**NOTE: Before installing unit, determine whether any building alterations are required to run piping, wiring and duct work. Follow all unit dimensional drawings and refer to the submittal engineering dimensional drawings of individual units for proper clearances.**

Refer to [Model Number Nomenclature](#) on page 5 and the appropriate submittal drawings, to determine the type of system being installed and anticipate building alterations, piping and duct work needed.

The unit dimensions, pipe-connection locations, and piping schematics are described in the submittal documents included in the .

- Verify that the floor is level, solid and sufficient to support the unit. See [Typical EconoPhase unit weights](#) on page 21. for unit weights.
- Allow at least the minimum recommended clearances for maintenance and service. See the appropriate submittal drawings for dimensions.
- We recommend installing an under-floor water detection system. Contact your Vertiv representative for information.

### 4.1 Standard Air-cooled Systems versus Liebert EconoPhase Systems

There are differences between the standard air-cooled Liebert® DSE™ system and a system designed with the Liebert® EconoPhase. You should be aware of these differences to achieve the best operation the Liebert® DSE and Liebert® EconoPhase. This section summarizes the differences.

- **Liebert® EconoPhase Operation**—when the outdoor temperature is low enough to provide the required temperature difference between the indoor air and the outside air, the compressors turn off and the EconoPhase pumps turn on.
- **Refrigerant Pumping**—during EconoPhase operation, the refrigerant is pumped around the air-cooled loop instead of going through the vapor compression cycle. System pressures will vary significantly depending on whether the system is operating in standard, air-cooled mode or in EconoPhase operation.
- **Energy Savings**—the system's coefficient of performance increases significantly during EconoPhase operation, which results in significant energy savings.
- **EEV**—an electronic expansion valve is employed during both direct-expansion and EconoPhase operation. The EEV provides energy savings and helps the pump maintain proper differential during EconoPhase operation.
- **Piping**—The condenser piping is larger than the size typically specified for Liebert® Thermal Management systems. The pipe sizing allows oil return to the compressor and efficient operation in both modes of operation. All field-piped lines must be insulated because the fluid temperatures can be well below the dew point during EconoPhase operation. All outdoor insulation must be UV rated and rated for outdoor use.

- **Unit/Module Communications**—A CANbus connection links the Liebert® DSE and the condenser and the Liebert® EconoPhase to achieve the most efficient operation.

## 4.2 Determine Cooling Requirements of the System

Refer to the Liebert® DSE™ user manual for complete instructions.

1. Calculate the total cooling required.
2. Determine placement of the Liebert® units.
3. Determine required line sizes.
4. Calculate the refrigerant volume of the DSE/EconoPhase system.
5. Complete design details including, electrical, mounting, piping, etc.

## 4.3 Mechanical Considerations

The EconoPhase pump is located at the condenser (receiver) outlet and always needs liquid at its inlet for proper function. The lines between the receiver and the EconoPhase unit must be sloped down toward the EconoPhase unit without any traps and with minimal bends. Traps in those lines will prevent the pump from establishing and from maintaining flow.

It is equally important to pump operation that the receiver be sufficiently above the EconoPhase unit. See [Placement Options and Piping Restrictions for the EconoPhase Unit and Liebert MC Condenser](#) on page 28 for the proper height difference. The maximum equivalent piping between the Liebert® MC Condenser and EconoPhase unit is 25 ft (7.6 m). The EconoPhase unit must be mounted outdoors for proper operation.

It is also important that the circuits do not get crossed between the indoor unit, the condenser and the EconoPhase unit. If they get crossed, the system will not operate correctly, in DX mode or in EconoPhase operation.

## 4.4 Planning Dimensions

The unit is described in the submittal documents included in the [Submittal Drawings](#) on page 41.

The following table lists the relevant documents by number and title.

**Table 4.1 Dimension Planning Drawings**

Document Number	Title
DPN002326	Cabinet Dimensional Data, PR050 - PR250



## 4.5 EconoPhase Unit Weights

Table 4.2 Typical EconoPhase unit weights

Model	Circuits	Unit Voltage, Hz	Approximate Unit Weight, lb (kg)
PR050	1	208/230 V, 460 V, 60 Hz	217 (98)
		380 V, 575 V, 60 Hz	242 (110)
		415 V, 50 Hz	217 (98)
PR085 - PR250	2	208/230 V, 460 V, 60 Hz	340 (154)
		380 V, 575 V, 60 Hz	390 (177)
		415 V, 50 Hz	347 (157)
Source DPN002326 Rev. 9			

This page intentionally left blank

## 5 EQUIPMENT HANDLING

EconoPhase modules are installed with the Liebert® DSE™ and the Liebert® MC™ condenser or MCV™ condenser. When your system uses MCV condensers, the EconoPhase unit is factory-installed on the skid, so no unpacking or moving is needed.



**CAUTION:** Risk of contact with sharp edges, splinters, and exposed fasteners. Can cause injury. Only properly trained and qualified personnel wearing appropriate, OSHA-approved PPE should attempt to move, lift, remove packaging from or prepare the unit for installation.



**CAUTION:** Risk of handling heavy unit and component parts. Can cause injury and equipment damage. Use OSHA-recommended safe lifting techniques and/or lifting equipment rated for the weight of the unit.

See [Typical EconoPhase unit weights](#) on page 21, for unit weight.

### NOTICE

Risk of damage from forklift. Can cause unit damage. Keep tines of the forklift level and at a height suitable to fit below the skid and/or unit to prevent exterior and/or underside damage.

### 5.1 Unpacking and Moving the EconoPhase Unit

1. Referring to [Removing the shipping crate](#) on the next page, remove the screw and washers and the retaining clips from the shipping crate, then remove the crate from the unit.

Figure 5.1 Removing the shipping crate

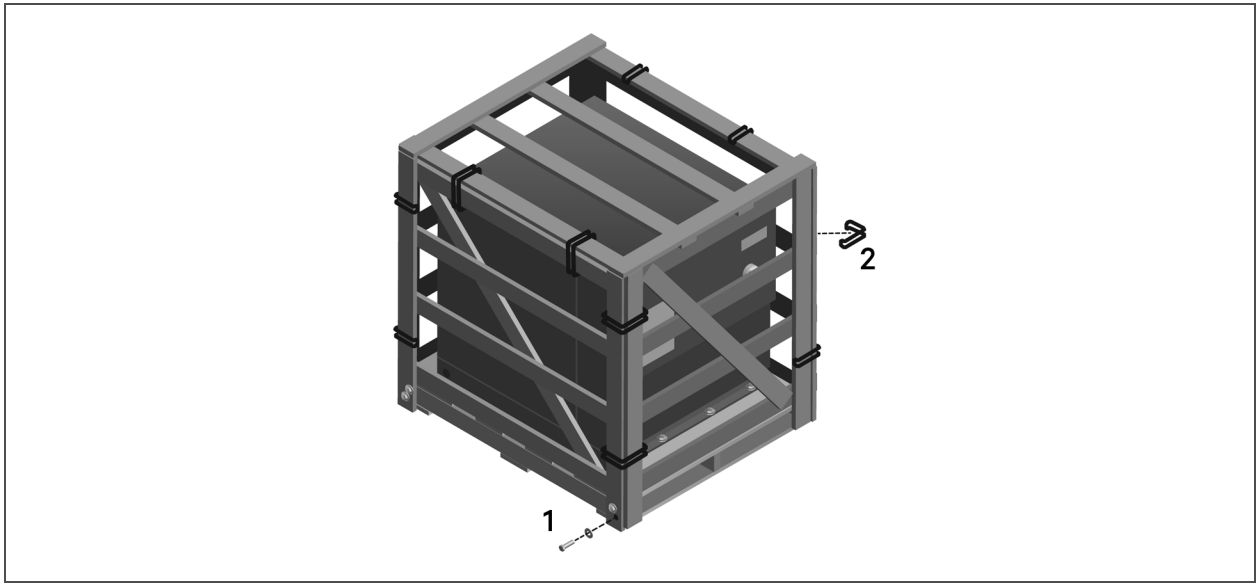

Item	Description	Item	Description
1	Screw and washer (typically 8 places)	2	Retaining clip (typically 12 places)

2. Remove the screws and washers that secure the unit to the skid, [Removing screws securing the unit to the skid](#) below.
3. Use the 4 1-1/32-in. (26.2-mm) diameter holes, shown in [Removing screws securing the unit to the skid](#) below, to lift and move the unit.
  - After installation, place the hole plugs that are included with the manual in the lifting holes.

**Figure 5.2 Removing screws securing the unit to the skid**

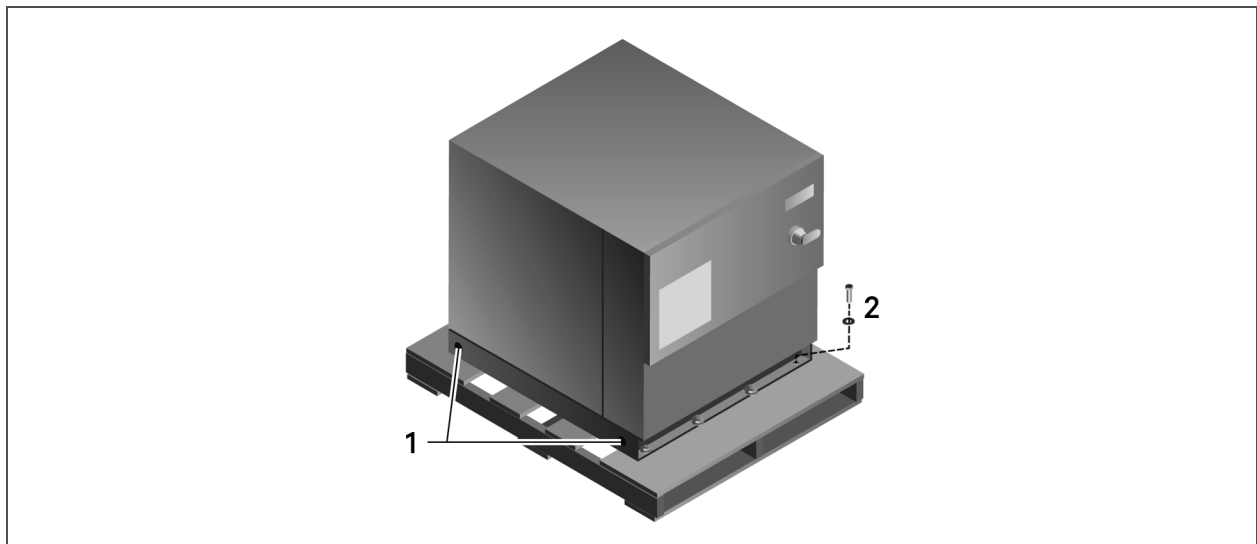

Item	Description	Item	Description
1	Lifting holes, 2 each side	2	Screw and washer (typically 8 places)

4. See [Typical sling arrangement for lifting unit](#) below, for the typical use of lifting holes and sling arrangement.

**Figure 5.3** Typical sling arrangement for lifting unit



## 6 PIPING AND REFRIGERANT REQUIREMENTS

Field-installed piping must be installed in accordance with local codes and must be properly assembled, supported, isolated and insulated. Avoid piping runs through noise-sensitive areas, such as office walls and conference rooms.

Refer to specific text and detailed diagrams in this manual for other unit-specific piping requirements.

The pipe connection locations, piping general arrangement and schematics are described in the submittal documents included in the [Submittal Drawings](#) on page 41.

The following tables list the relevant documents by number and title.

**Table 6.1 Typical EconoPhase-to-Condenser arrangement Drawings**

Document Number	Title
DPN003994	Mounting MC Condenser/EconoPhase Above or at Same Level as DA050 to DA165
DPN003965	Mounting MCV Heat-rejection Skid Above or at Same Level as DA125 to DA250

**Table 6.2 Piping General-arrangement Drawings**

Document Number	Title
<b>Schematics</b>	
DPN002615	EconoPhase with DSE Piping Schematic DA050, DA080, DA085
DPN002340	EconoPhase with DSE Piping Schematic DA125, DA150, DA165
DPN004476	EconoPhase with DSE Piping Schematic DA125, DA150, DA165, DA250
<b>Internal Piping</b>	
DPN003553	Single-circuit Internal Piping General Arrangement, PR050 models
DPN002325	Dual-circuit Internal Piping General Arrangement, PR085 - PR250 models

## 6.1 Placement Options and Piping Restrictions for the EconoPhase Unit and Liebert MC Condenser

The Liebert® MC condenser and EconoPhase must be installed next to each other (For guidelines, refer to the appropriate drawing for your system in the [Submittal Drawings](#) on page 41. The EconoPhase is dependent on sub-cooled liquid leaving the condenser and entering the pumps. For this reason there must be no large pressure drop between the two units because that could lead to flashing of the refrigerant and pump cavitation. There must be no traps in the liquid line between the condenser and the EconoPhase unit because these will allow vapor to enter the pump suction during start up.

**NOTE: The condenser must not be installed below the level of the DSE. The condenser may be installed on the same level as the DSE or as much as 60 ft (18.3 m) above the DSE. See DPN003994 in the [Submittal Drawings](#) on page 41, for details.**

## 6.2 Refrigerant Line Sizing in an EconoPhase System

Proper line size selections are critical to proper operation of the EconoPhase system. The line sizes shown in [Line sizing for DSE/EconoPhase System](#) below, must be followed for proper operation and maximum efficiency of the EconoPhase and vapor compression modes. The line size selections have been optimized to reduce pressure drop throughout the system and still maintain oil return to the compressor for reliability.

Refer to the Liebert® DSE user manual for complete list of piping guidelines and instructions.

**Table 6.3 Line sizing for DSE/EconoPhase System**

Model	DA050		DA080 and DA085		DA125		DA150 and DA165		DA250	
	Hot Gas Line, in.	Liquid Line, in.	Hot Gas Line, in.	Liquid Line, in.	Hot Gas Line, in.	Liquid Line, in.	Hot Gas Line, in.	Liquid Line, in.	Hot Gas Line, in.	Liquid Line, in.
50 ft (15 m)	1-1/8	7/8	1-1/8	7/8	1-3/8	7/8	1-3/8	7/8	1-5/8	1-3/8
100 ft (30 m)	1-1/8	7/8	1-1/8	7/8	1-3/8	7/8	1-3/8	1-1/8	1-5/8	1-3/8
150 ft (45 m)	1-1/8	7/8	1-1/8	7/8	1-3/8	7/8	1-3/8	1-1/8	1-5/8*	1-3/8*
300 ft (90 m)	1-1/8	7/8	1-1/8	7/8	1-3/8	7/8	1-3/8	1-1/8	1-5/8*	1-3/8*
450 ft (137 m)*	1-1/8	7/8	1-1/8	7/8	1-3/8	7/8	1-3/8	1-1/8	—	—

\*Consult factory when actual pipe length between condenser/EconoPhase and Liebert DSE unit will exceed 300 ft (91 m). The DA250 unit can be extended to a maximum 200-ft (61-m) linear or 300-ft (91-m) equivalent length.

Source: DPN000788. Rev. 13



## 6.2.1 Refrigerant Charge for EconoPhase Systems



**WARNING!** Risk of over-pressurization of the refrigeration system. Can cause explosive discharge of high-pressure refrigerant, loss of refrigerant, environmental pollution, equipment damage, injury, or death. This unit contains fluids and gases under high pressure. Use extreme caution when charging the refrigerant system. Do not pressurize the system higher than the design pressure marked on the unit's nameplate. For systems requiring EU CE compliance (50 Hz), the system installer must provide and install a pressure relief valve in the high side refrigerant circuit that is rated same as the refrigerant high side “Max Allowable Pressure” rating that is marked on the unit serial tag. The pressure relief valve must be CE-certified to the EU Pressure Equipment Directive by an EU “Notified Body.”

Before charging system, make sure disconnect switch is in the “OFF” position. After charging is complete, turn disconnect switch to the “ON” position. Refer to the Liebert® DSE Installer/User Guide (SL-18933) for complete charging instructions for the DSE/EconoPhase system.

**Table 6.4 EconoPhase refrigerant charge**

Model	R410A Charge per Circuit, lb (kg)
PR050	5.4 (2.5)
PR085	5.4 (2.5)
PR125	5.4 (2.5)
PR250	9.2 (4.2)

This page intentionally left blank

## 7 ELECTRICAL CONNECTIONS

 **WARNING!** Arc flash and electric shock hazard. Open all local and remote electric power disconnect switches, verify with a voltmeter that power is Off and wear personal protective equipment (PPE) per NFPA 70E before working within the electric control enclosure. Failure to comply can cause serious injury or death. The Liebert® controller does not isolate power from the unit, even in the “Unit Off” mode. Some internal components require and receive power even during the “Unit Off” mode of the controller. The only way to ensure that there is NO voltage inside the unit is to install and open a remote disconnect switch. Refer to unit electrical schematic. Follow all local codes.

 **WARNING!** Risk of improper wiring, piping, moving, lifting and handling. Can cause equipment damage, serious injury or death. Installation and service of this equipment should be done only by qualified personnel who have been specially-trained in the installation of air-conditioning equipment and who are wearing appropriate, OSHA-approved PPE.

 **WARNING!** Risk of undersized wiring and/or loose electrical connection terminals. Can cause overheated wire and electrical components resulting in smoke, fire, equipment and building damage, injury or death. Use correctly sized copper wire only and verify that all electrical connections are tight before turning power On. Periodically check all electrical connections to verify that they remain tight.

 **CAUTION:** Risk of electric shock and short circuits. Can cause equipment damage, injury or death. Insert CSA certified or UL listed bushings into holes and or knockouts used to route wiring through to protect the wire insulation from contact with sheet metal edges.

### NOTICE

Risk of improper electrical connection of three-phase input power. Can cause unit damage.

Service technicians should use a gauge set during the initial start-up to verify that the three-phase power is connected properly.

**NOTE:** Seal openings around piping and electrical connections to prevent air leakage.

## 7.1 High-voltage Electrical Connections

Three-phase electrical service is required for all models. Electrical service must conform to national and local electrical codes. Refer to equipment nameplate regarding wire size and circuit protection requirements. Refer to electrical schematic when making connections. A manual electrical disconnect switch should be installed in accordance with local codes and distribution system. Consult local codes for external disconnect requirements.

The electrical connections and service entrances to the unit are described in the submittal documents included in the [Submittal Drawings](#) on page 41.

The following table lists the relevant documents by number and title.

**Table 7.1 Electrical Field-connection Drawings**

Document Number	Title
DPN004355	Electrical Field Connections, PR050 Models
DPN002327	Electrical Field Connections, PR085 - PR250 Models

## 7.2 Low-voltage, Communication Wiring Connections

The Liebert® DSE™, MC™ condenser, and EconoPhase PRE require communication when combined into a system. This is done through a CANbus communication interface. A CANbus cable must be connected from the DSE at the designated terminal(s) to TB49 on the MC-condenser board (refer to the Liebert® DSE user manual, SL-18934). If there is an additional condenser, TB50 of the first condenser will continue out to TB49 on the second condenser.

In a system equipped with an EconoPhase, the CANbus cable must be connected from TB50 on the last condenser to TB49 on the EconoPhase CANbus terminal block.

The two devices that are connected at the ends of the CANbus will require termination to be set by jumper or plug. One end will be at the last outdoor device in the connection chain; the other end of the CANbus is either in the indoor unit or at a remote sensor. To terminate, place a jumper on J6 Pins 1 and 2 on the MC condenser or EconoPhase board. For other Liebert® iCOM™ boards directly associated with the indoor unit, terminate by placing a jumper on P78 Pins 2 and 3.

See [CANbus cable connections for single-circuit system, PR050 and DA050](#) on the facing page or [CANbus cable connections for dual-circuit system, PR080 to PR250](#) on page 34 for CANbus connections, jumper and DIP switch settings.

- Length Restrictions
  - The indoor DSE™ can be no more than 300 ft. (91 m) from the condenser. The CAN communication cable can be longer, but the total length should not exceed 500 ft. (152 m) between the indoor DSE unit and all outdoor equipment.

- Cable Type
  - Conductors—22-18AWG stranded, tinned copper
  - Twisted pair (one pair is required for connection)
  - Braided shield or foil shield with drain wire
  - Low capacitance ( $\leq 15\text{pF/ft}$ )
  - Cat5e or similar
  - UL approved temperature rated to  $75^{\circ}\text{C}$  ( $167^{\circ}\text{F}$ )
  - UL approved voltage rated to 300 V
  - UV – and moisture – resistant if not run in conduit
  - Plenum rated—NEC type CMP, if required by national or local codes
- High Voltage Restrictions
  - Do not run communications cable with high voltage cable.
  - When routing cable, avoid laying, fastening or coiling near or on high voltage wiring, conduit, or light ballasts. Communication signals in equipment may be disturbed.
  - Keep communications cable away from other electrical noise sources.
- Environmental and Safety
  - We recommend routing cable inside conduit where the cable exits the building to outdoor units, between outdoor units and any other location where environmental conditions could degrade the cable's integrity.
  - Follow all national and local codes regarding cable routing, ratings, etc.

**Figure 7.1 CANbus cable connections for single-circuit system, PR050 and DA050**

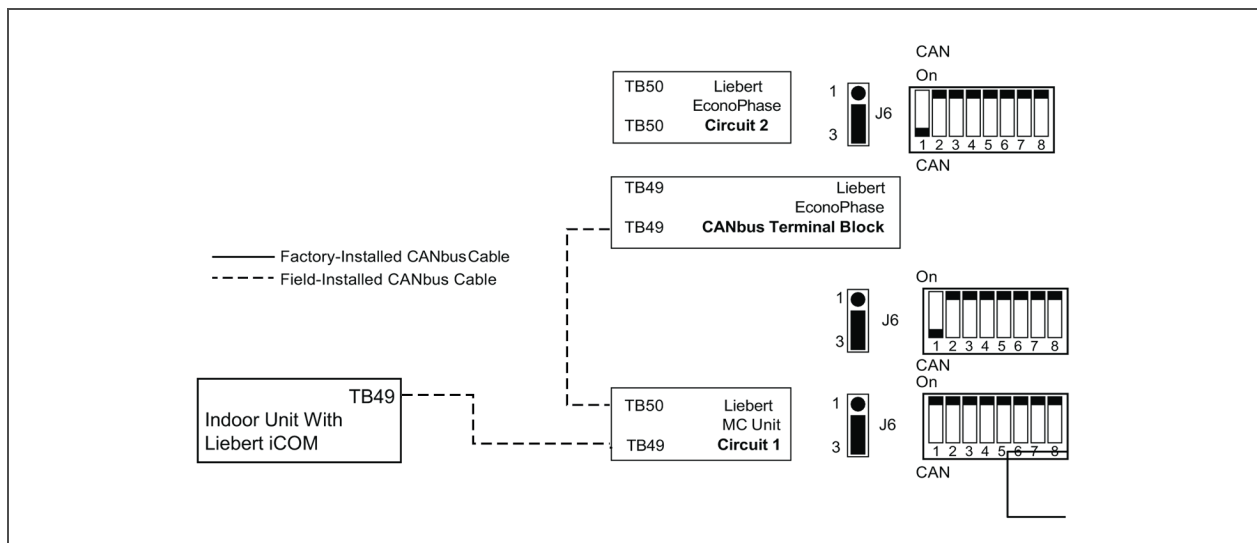
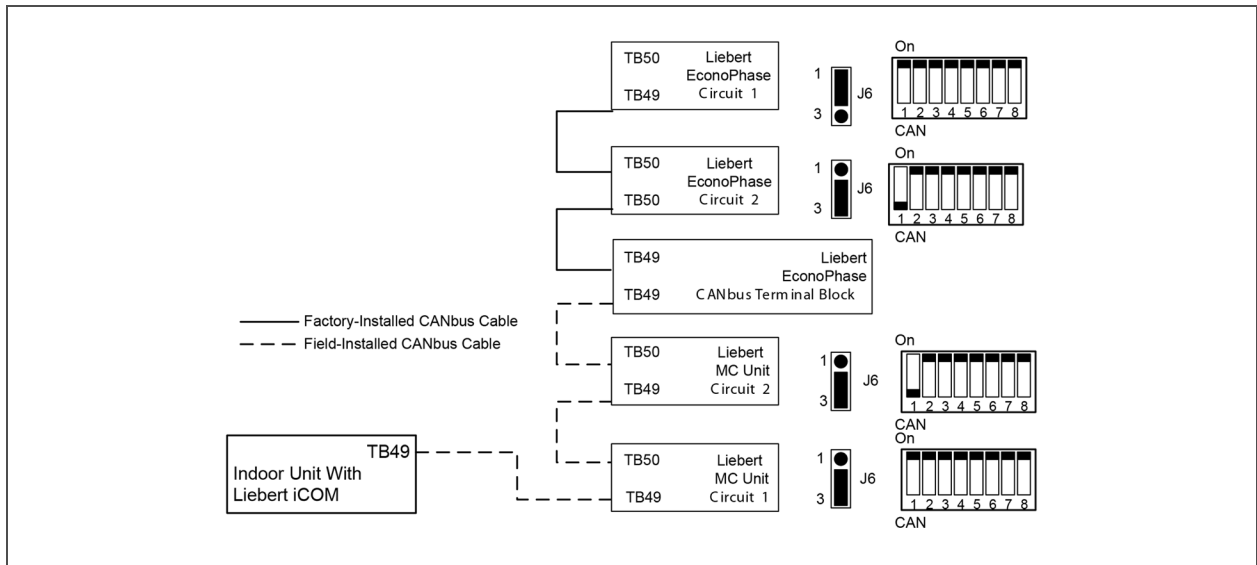

Figure 7.2 CANbus cable connections for dual-circuit system, PR080 to PR250



## 8 TROUBLESHOOTING

[EconoPhase alarms and possible causes](#) below, shows the current list of alarms that will display, along with a list of possible causes for the alarm condition.

**Table 8.1 EconoPhase alarms and possible causes**

Liebert® iCOM Alarm Text	Event Description	Notes (Possible Causes / Troubleshooting)	Reset Type MA = Manual Acknowledge MR = Manual Reset AR = Auto Reset
PB1/2 BOARD FAIL	An unrecoverable fatal system error has occurred. Pump shut down. Pump board must be rebooted to reset event.	Reboot system but a new pump board must be installed.	MA, MR
PB1/2 IN PRES SENS FAIL	Inlet refrigerant pressure sensor failure. Pump shut down. Event is reset when condition clears.	Plug disconnected at board. Disconnected at sensor. Sensor failure.	MA, AR
PB1/2 IN TEMP SENS FAIL	Inlet refrigerant temperature sensor failure. Pump shut down. Event is reset when condition clears.	Sensor unplugged at board. Lead material separated from resistor element (damaged sensor). Short circuit.	MA, AR
PB1/2 INV DATA SHUTDOWN	Invalid data detected and pump has been shut down. Event is reset when Liebert® iCOM requests a new start up.	CAN communication error Software error (reboot system if occurring continually) Mismatched versions of code between the Liebert® iCOM and Pump boards.	MA, AR
PB1/2 LO DIFF PRESSURE	Pump differential pressure fell below a lower threshold and pump has been shut down. Event is reset when Liebert® iCOM requests a new start up.	EEV not operating properly (see EEV operating mode for EconoPhase). Pump phased incorrectly. Pressure transducers reversed. Pressure transducers reading incorrectly. Line between condenser and EconoPhase not sloped properly or has traps. Pump failure (mechanical or electrical).	MA, AR

**Table 8.1 EconoPhase alarms and possible causes (continued)**

Liebert® iCOM Alarm Text	Event Description	Notes (Possible Causes / Troubleshooting)	Reset Type MA = Manual Acknowledge MR = Manual Reset AR = Auto Reset
PB1/2 LO OUTLET TEMP	Pump outlet refrigerant temperature fell below a lower threshold and pump has been shut down. Event is reset when iCOM requests a new start up.	Refrigerant temperature sensor failure at condenser outlet. Condenser fans not operating correctly. Indoor load too low at very low outdoor temperatures.	MA, AR
PB1/2 OUT PRES SEN FAIL	Outlet refrigerant pressure sensor failure. Pump shut down. Event is reset when condition clears.	Plug disconnected at board. Disconnected at sensor. Sensor failure.	MA, AR
PB1/2 OUT TEMP SEN FAIL	Outlet refrigerant temperature sensor failure. Pump shut down. Event is reset when condition clears.	Sensor unplugged at board. Lead material separated from resistor element (damaged sensor). Short circuit.	MA, AR
PB1/2 COMMS ERROR	Liebert® iCOM lost CAN communications with pump board. Pump shut down. Event is reset when condition clears.	Hardware failure on the pump board. Pump board should be replaced.	MA, AR
PB1/2 REMOTE SHUTDWN	Remote shutdown alarm state. Pump shut down. Event is reset when condition clears.	Jumper removed on PCB at TB38.	MA, AR



**Table 8.1 EconoPhase alarms and possible causes (continued)**

Liebert® iCOM Alarm Text	Event Description	Notes (Possible Causes / Troubleshooting)	Reset Type MA = Manual Acknowledge MR = Manual Reset AR = Auto Reset
PB1/2 STARTUP FAIL	Three pump start ups in a row have failed. Event must be manually reset by user.	<p>Low refrigerant charge.</p> <p>Pump phased incorrectly.</p> <p>Pressure transducers reversed.</p> <p>Pressure transducers reading incorrectly.</p> <p>Line between condenser and EconoPhase not sloped properly or has traps.</p> <p>Condenser fans not operating properly. (See condenser operating mode for EconoPhase).</p> <p>EEV not operating properly (see EEV operating mode for EconoPhase).</p> <p>Pump failure (mechanical or electrical).</p> <p>Refrigerant circuits crossed.</p>	MA, MR
PB1/2 COMMUNICATE FAIL	<p>Ethernet communications failure. Pump not shut down. Event is reset when condition clears.</p> <p>USB communications failure. Pump not shut down. Event is reset when condition clears.</p>	Hardware failure on the pump board. Pump board should be replaced.	MA, AR
PB1/2 INVERTER FAIL	Pump Board inverter fail.	Refer to inverter display and manual for cause of failure.	MA, AR
PB1/2 PUMP HRS EXCEEDED	EconoPhase pump hours exceeded. Event is reset when condition clears.	Hours since last maintenance have exceeded the designated limit.	MA, AR
PB1/2 TVSS FAILURE		Power surge has tripped TVSS. TVSS must be replaced.	MA, AR

This page intentionally left blank

# APPENDICES

## Appendix A: Technical Support and Contacts

### A.1 Technical Support/Service in the United States

Vertiv™ Group Corporation

24x7 dispatch of technicians for all products.

1-800-543-2378

Liebert® Thermal Management Products

1-800-543-2778

Liebert® Channel Products

1-800-222-5877

Liebert® AC and DC Power Products

1-800-543-2378

### A.2 Locations

#### United States

Vertiv Headquarters

1050 Dearborn Drive

Columbus, OH, 43085, USA

#### Europe

Via Leonardo Da Vinci 8 Zona Industriale Tognana

35028 Piove Di Sacco (PD) Italy

#### Asia

7/F, Dah Sing Financial Centre

3108 Gloucester Road

Wanchai, Hong Kong

This page intentionally left blank

## Appendix B: Submittal Drawings

The submittal drawings are in the order of document part number (DPN). **Table B.1** below, groups the drawings by topic/application.

**Table B.1 Submittal-drawings Contents**

Document Number	Title
<b>Dimensional Planning Drawings</b>	
DPN002326	Cabinet Dimensional Data, PR050 - PR250
<b>EconoPhase-to-Condenser arrangement</b>	
DPN003994	Considerations for mounting MC Condenser/EconoPhase Above or at Same Level as DSE
DPN003965	Mounting MCV Heat-rejection Skid Above or at Same Level as DA125 to DA250
<b>Piping Schematics</b>	
DPN002615	EconoPhase with DSE piping Schematic DA050, DA080, DA085
DPN002340	EconoPhase with DSE Piping Schematic DA125, DA150, DA165
DPN004476	EconoPhase with DSE Piping Schematic DA125, DA150, DA165, DA250
<b>Unit Internal Piping</b>	
DPN003553	Single-circuit Internal Piping General Arrangement, PR050 models
DPN002325	Dual-circuit Internal Piping General Arrangement, PR085 - PR250 models
<b>Electrical Field Connection</b>	
DPN004355	Electrical Field Connections, PR050 Models
DPN002327	Electrical Field Connections, PR085 - PR250 Models

This page intentionally left blank

# LIEBERT ECONOPHASE

## TYPICAL GENERAL ARRANGEMENT DIAGRAM PR085 - PR250 MODELS

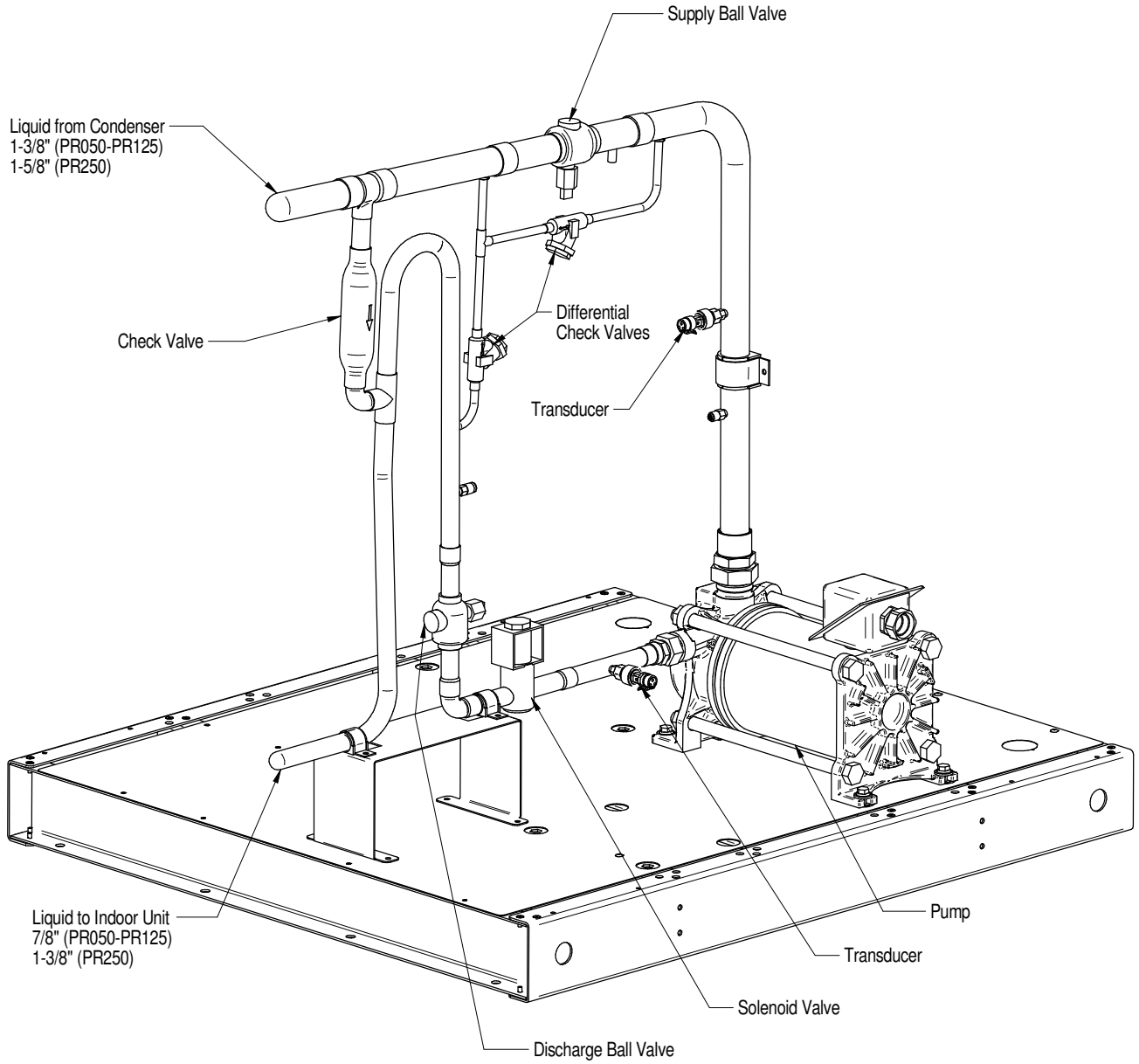

Single Pump Circuit shown  
(Typical 2 Circuit Systems)

## CABINET DIMENSIONAL DATA PR050 - PR250

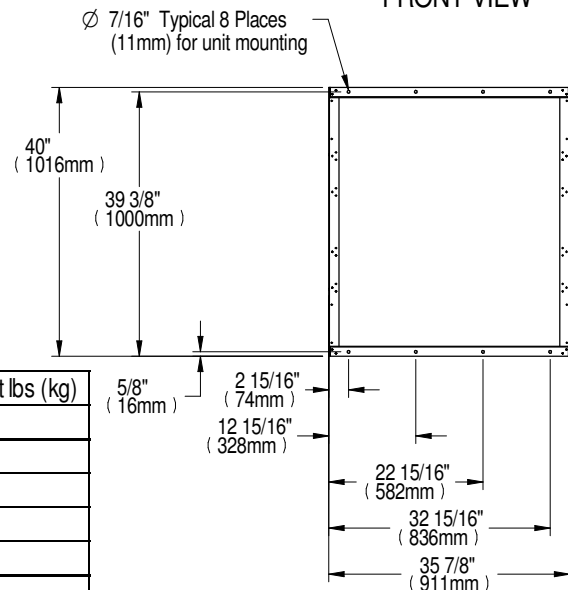
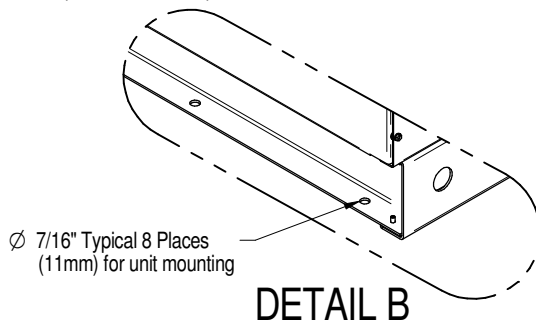
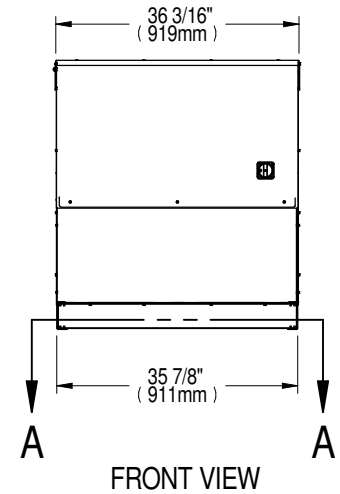
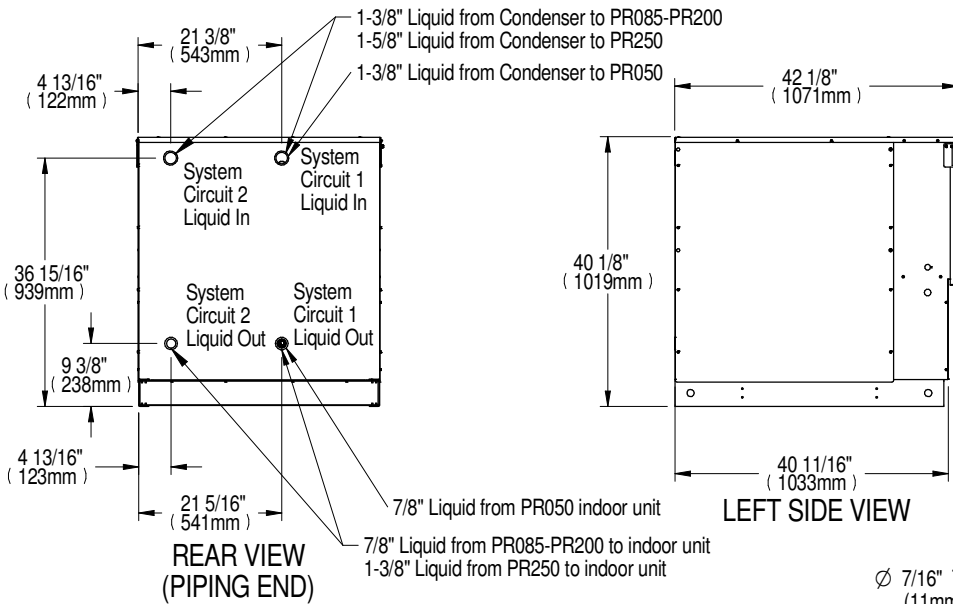
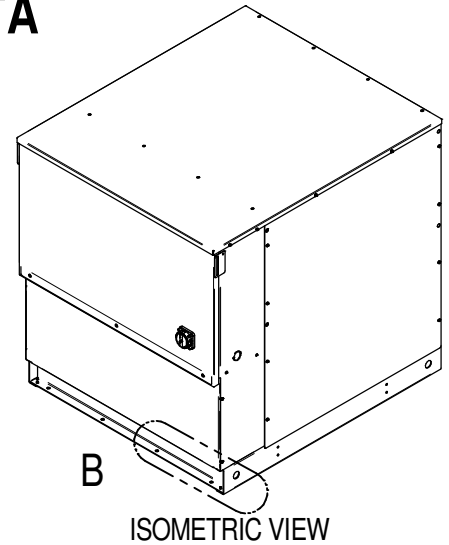
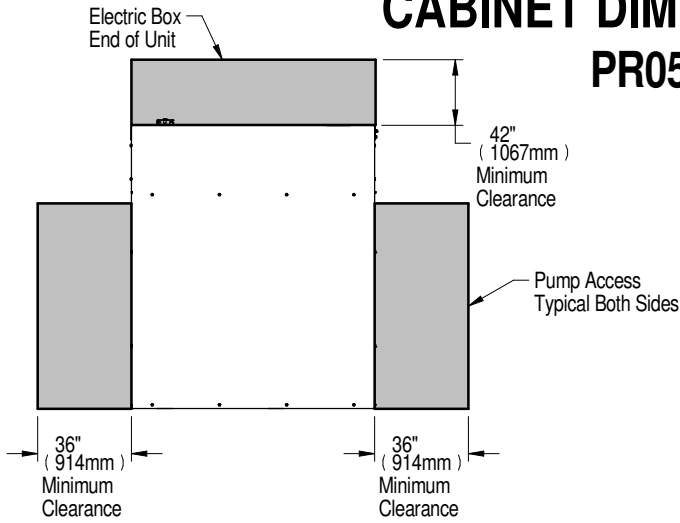

Model	Circuits	Unit Voltage, Hz	Approximate Dry Weight lbs (kg)
PR050	1	208/230V, 460V 60Hz	217 (98)
		380V, 575V 60Hz	242 (110)
		415V 50Hz	217 (98)
PR085-125 and PR250	2	208/230V, 460V 60Hz	340 (154)
		380V, 575V 60Hz	390 (177)
		415V 50Hz	347 (157)
PR200	2	460V 60Hz	350 (159)

### SECTION A-A





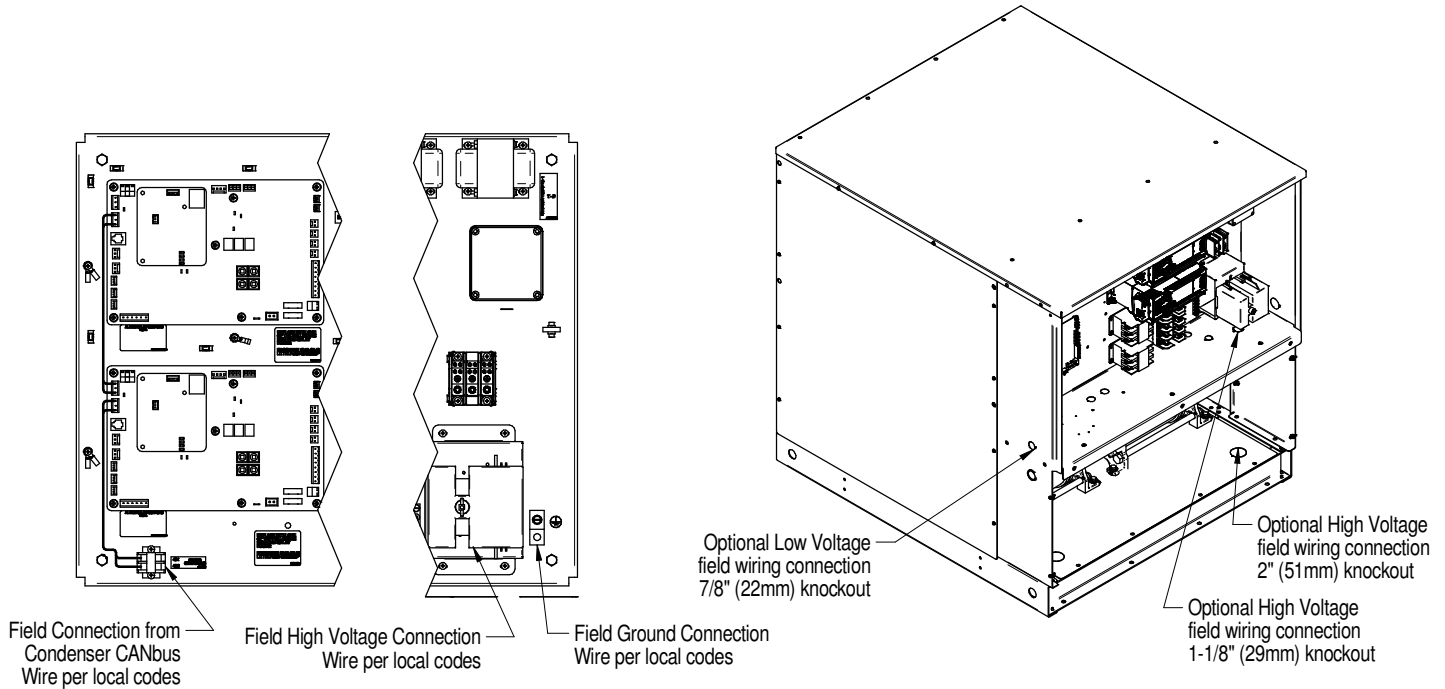

## ELECTRICAL FIELD CONNECTIONS PR085 - PR250 DUAL CIRCUIT MODELS

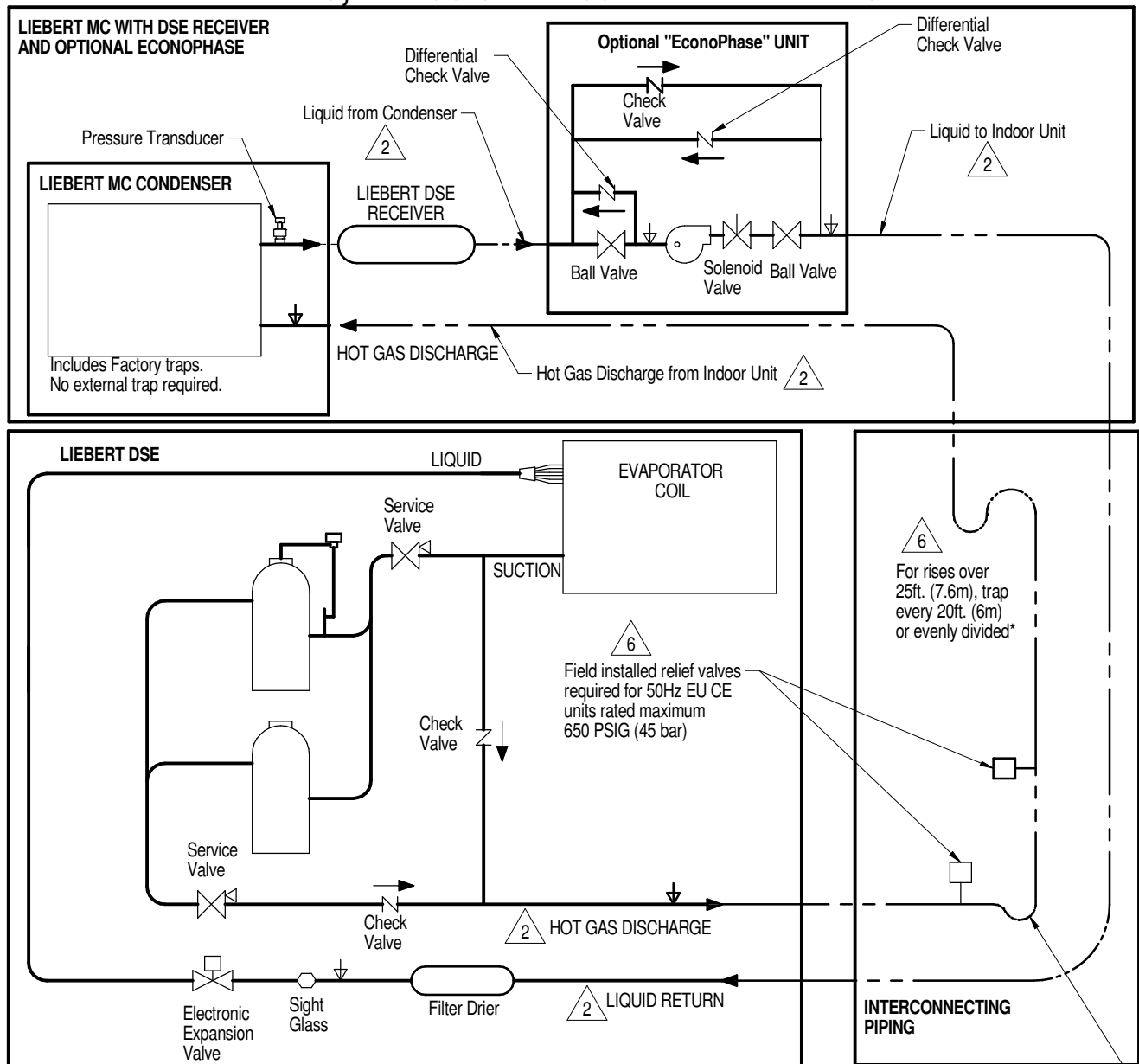

Model	Unit Electrical Specifications						Single Pump Motor (one pump per circuit)			
	Voltage	Phase	Hz	FLA	Minimum Supply Circuit Ampacity	Maximum Fuse Size	HP	FLA		
PR085AA***-	460	3	60	7.0	7.9	15	1.6	3.5		
PR125AA***-										
PR250AA***2										
PR085AY***-	208/230			13.8	15.5	20				
PR125AY***-										
PR250AY***2										
PR085AB***-	575		5.6	6.3	15					
PR125AB***-										
PR250AB***2										
PR085A2***-	380		8.4	9.5	15					
PR125A2***-										
PR250A2***2										
PR085AG***-	415	50	7.4	8.3	15	1.2	3.7			
PR125AG***-										
PR250AG***2										
PR085AA***H	460	60	2.6	2.9	15	0.75	1.3			
PR085AY***H	208/230							5.2	5.9	
PR085AB***H	575									2
PR085A2***H	380		3.2	3.6			1.6			
PR085AG***H	415							2.4	2.7	
PR200AA***3	460									4.6

## PIPING SCHEMATIC DA125, DA150 & DA165 W/ LIEBERT MC



FACTORY REFRIGERANT PIPING      SERVICE/SCHRADER (ACCESS) CONNECTION, NO VALVE CORE.  
 FIELD PIPING      SERVICE/SCHRADER (ACCESS) CONNECTION, WITH VALVE CORE.      Trap at base of risers over 5ft. (1.5m)\*

- Notes:
1. Two refrigeration circuits provided. Single refrigeration circuit shown for clarity.
  2. Circuit 1 must be maintained between indoor unit, condenser and EconoPhase unit. Circuit 2 must be maintained between indoor unit, condenser and EconoPhase unit.
  3. Schematic representation shown. Do not use for specific connection locations.
  4. The outlet of the receiver must be higher than the elevation of the EEV inside the indoor unit. This vertical height must not exceed 60ft. (18.3m). Liebert DSE Receiver required for systems with or without EconoPhase.
  5. All indoor and outdoor field refrigerant piping must be insulated, 1/2" minimum thickness. All outdoor insulation must be UV and ozone resistant.
  6. Components are not supplied by Liebert but are required for proper circuit operation and maintenance.
  7. Traps must be installed and horizontal lines pitched to ensure proper oil return and to reduce liquid flood back to compressor. Pitch horizontal gas piping at a minimum of 1/2" per 10 feet (42mm per 10m) so that gravity will aid in moving oil in the direction of the refrigeration flow.
  8. Do not isolate any refrigerant circuits from over pressurization protection.

## PIPING SCHEMATIC DA050, DA080 & DA085 MODELS W/ LIEBERT MC

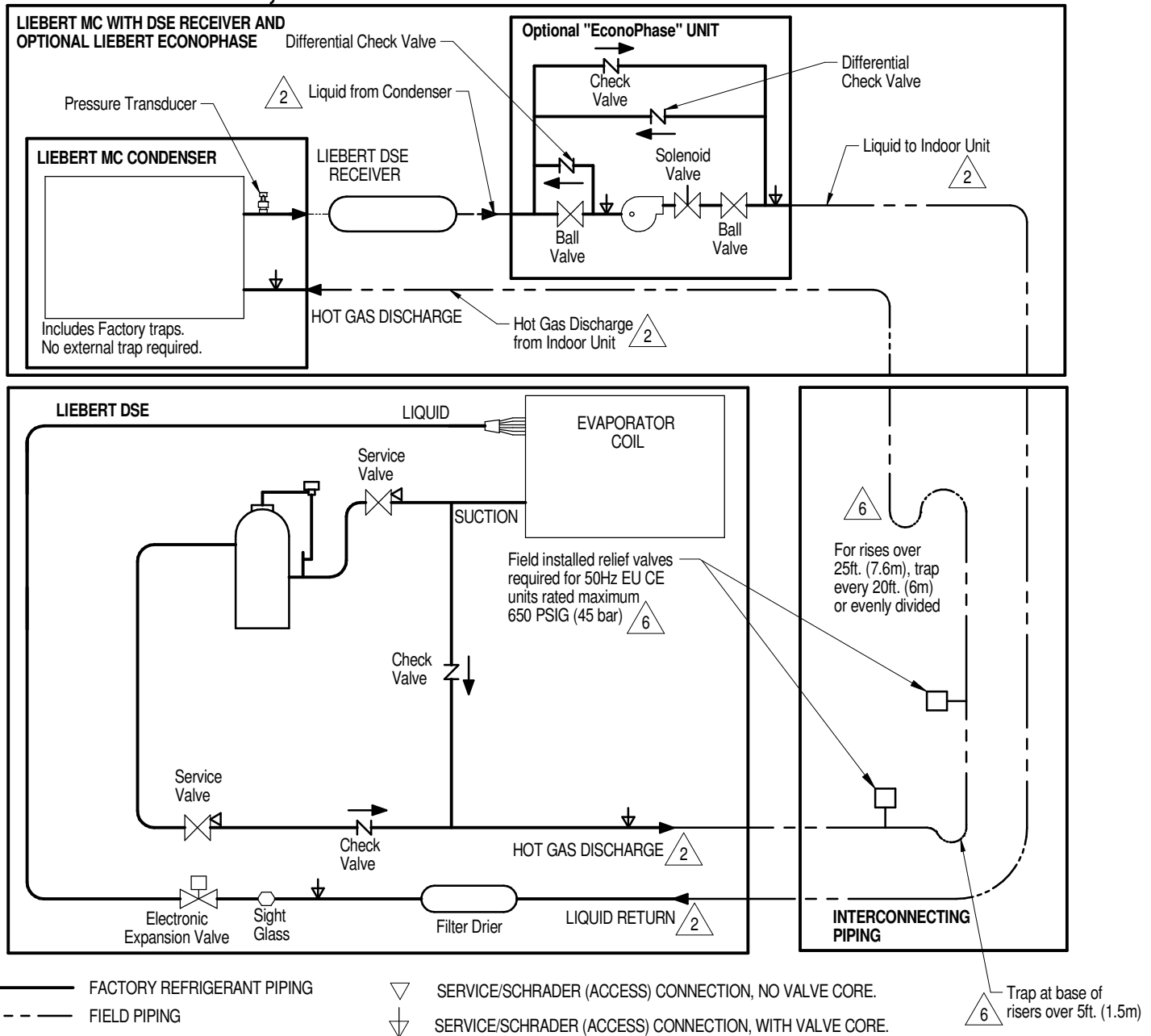

————— FACTORY REFRIGERANT PIPING      ▽ SERVICE/SCHRADER (ACCESS) CONNECTION, NO VALVE CORE.  
 - - - - - FIELD PIPING      ▾ SERVICE/SCHRADER (ACCESS) CONNECTION, WITH VALVE CORE.

- Notes:
- Two refrigeration circuits provided on DA080 & DA085. Single refrigeration circuit provided on DA050. Single refrigeration circuit shown for clarity.
  - Circuit 1 must be maintained between indoor unit, condenser and EconoPhase unit. Circuit 2 must be maintained between indoor unit, condenser and EconoPhase unit.
  - Schematic representation shown. Do not use for specific connection locations.
  - The outlet of the receiver must be higher than the elevation of the EEV inside the indoor unit. This vertical height must not exceed 60ft. (18.3m). Liebert DSE Receiver required for systems with or without EconoPhase unit.
  - All indoor and outdoor field refrigerant piping must be insulated, 1/2" minimum thickness. All outdoor insulation must be UV and ozone resistant.
  - Components are not supplied by Liebert but are required for proper circuit operation and maintenance.
  - Traps must be installed and horizontal lines pitched to ensure proper oil return and to reduce liquid flood back to compressor. Pitch horizontal hot gas piping at a minimum of 1/2" per 10 feet (42mm per 10m) so that gravity will aid in moving oil in the direction of refrigeration flow.
  - Do not isolate any refrigeration circuits from over pressurization protection.

# LIEBERT ECONOPHASE

## GENERAL ARRANGEMENT DIAGRAM PR050 MODELS

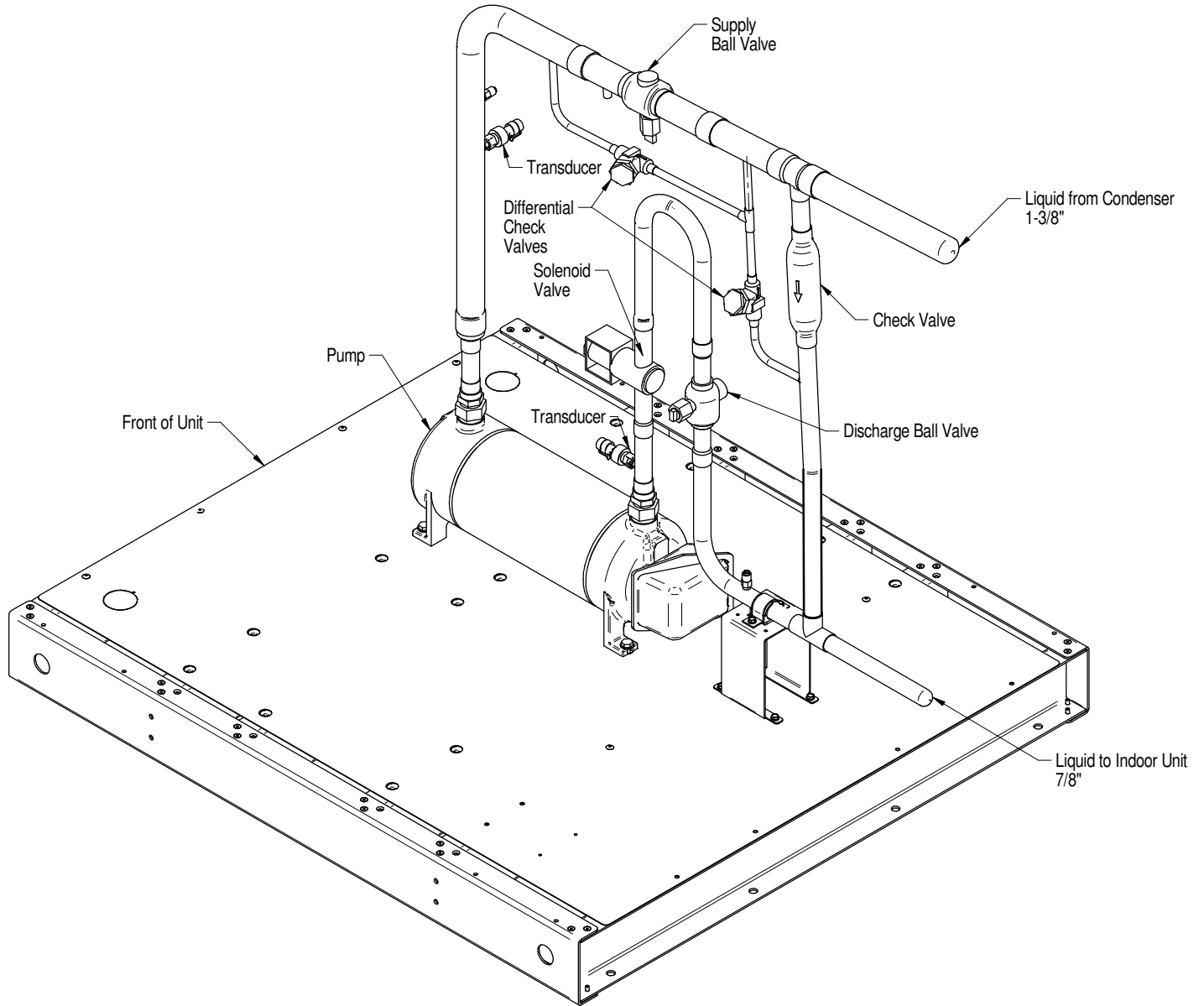

## AIR COOLED PIPING SCHEMATIC LIEBERT MCV MOUNTED ABOVE LIEBERT DA125-250

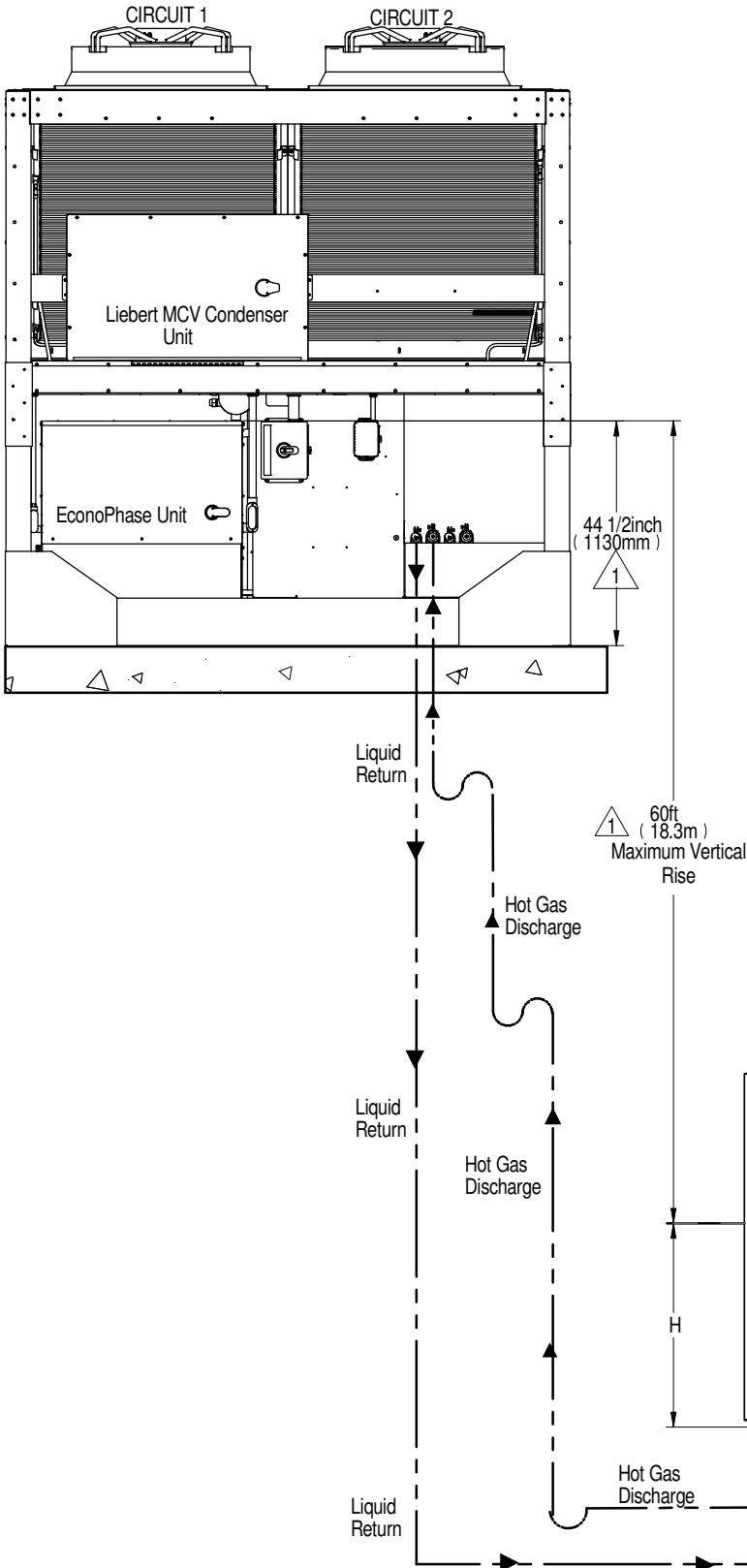

Notes:

1.  The outlet of the receiver must be higher than the elevation of the EEV inside the indoor unit. The vertical height must not be greater than 60 ft (18.3 m).
2. Unit must be trapped at bottom of riser with any rise over 5 feet (1.5m) high. If rise exceeds 25 feet (7.5m), then a trap is required in 20 foot (6.1m) increments or evenly divided. DA250 with horizontal discharge has internally installed traps on the hot gas discharge line.
3. Pitch horizontal hot gas piping at a minimum of 1/2 inch per 10 feet (42mm per 10m) so that gravity will aid in moving oil in the direction of the refrigeration flow.
4. Unit piping entrance varies by unit and may be through the top of the unit.
5. All indoor and outdoor field refrigerant piping must be insulated, 1/2 inch minimum. All outdoor insulation must be UV and ozone resistant.
6. Consult factory for any exceptions to the above guidelines.

Internal EEV Height	H inch ( mm)
DA125-DA165	43 (1092)
DA250	56 (1422)

----- Field Piping

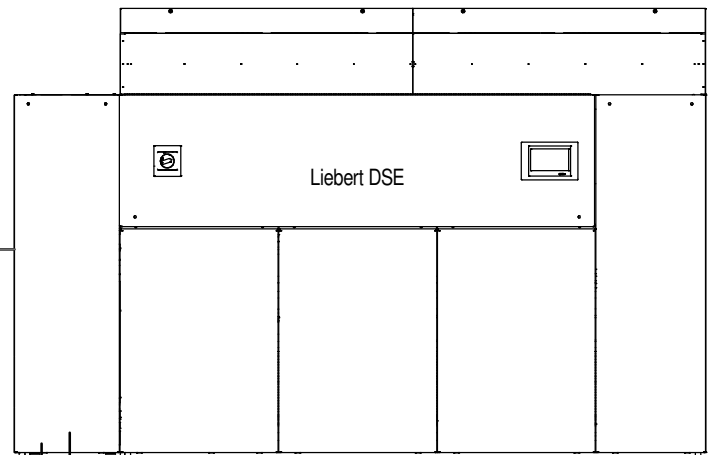

Notes:

- DA250 with horizontal discharge should be piped out the top of the unit.

## AIR COOLED PIPING SCHEMATIC LIEBERT MCV AND LIEBERT DA125-250 AT SIMILAR LEVEL

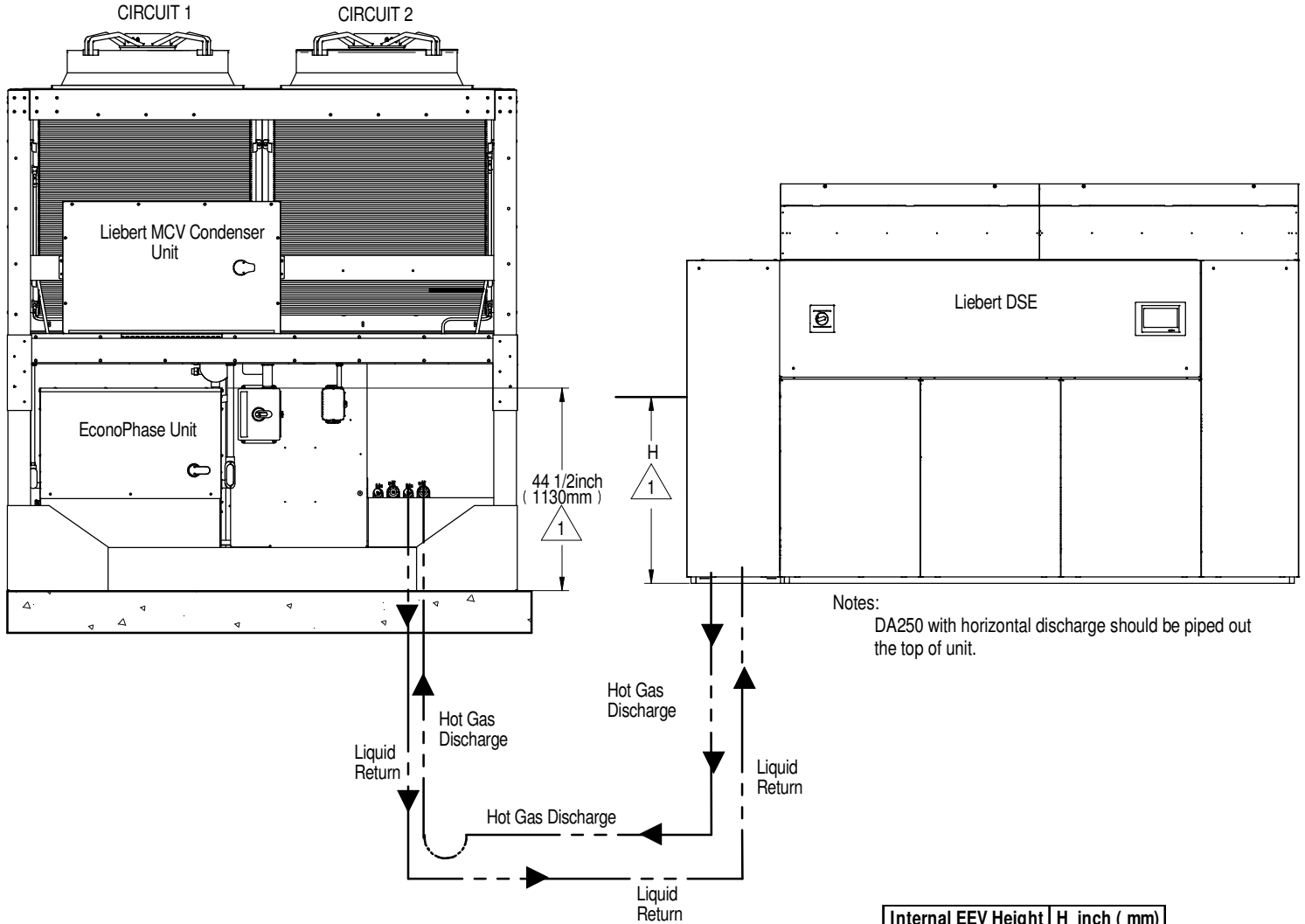

Notes:  
DA250 with horizontal discharge should be piped out the top of unit.

Notes:

1.  The outlet of the receiver must be higher than the elevation of the EEV inside the indoor unit.
2. Unit must be trapped at bottom of riser with any rise over 5 feet (1.5m) high. If rise exceeds 25 feet (7.5m), then a trap is required in 20 foot (6.1m) increments or evenly divided. DA250 with horizontal discharge has internally installed traps on the hot gas discharge line.
3. Pitch horizontal hot gas piping at a minimum of 1/2 inch per 10 feet (42mm per 10m) so that gravity will aid in moving oil in the direction of the refrigeration flow.
4. Unit piping entrance varies by unit and may be through the top of the unit.
5. All indoor and outdoor field refrigerant piping must be insulated, 1/2 inch minimum. All outdoor insulation must be UV and ozone resistant.
6. Consult factory for any exceptions to the above guidelines.

----- Field Piping



## AIR COOLED PIPING SCHEMATIC LIEBERT MC AND LIEBERT DA050-165 AT SIMILAR LEVELS

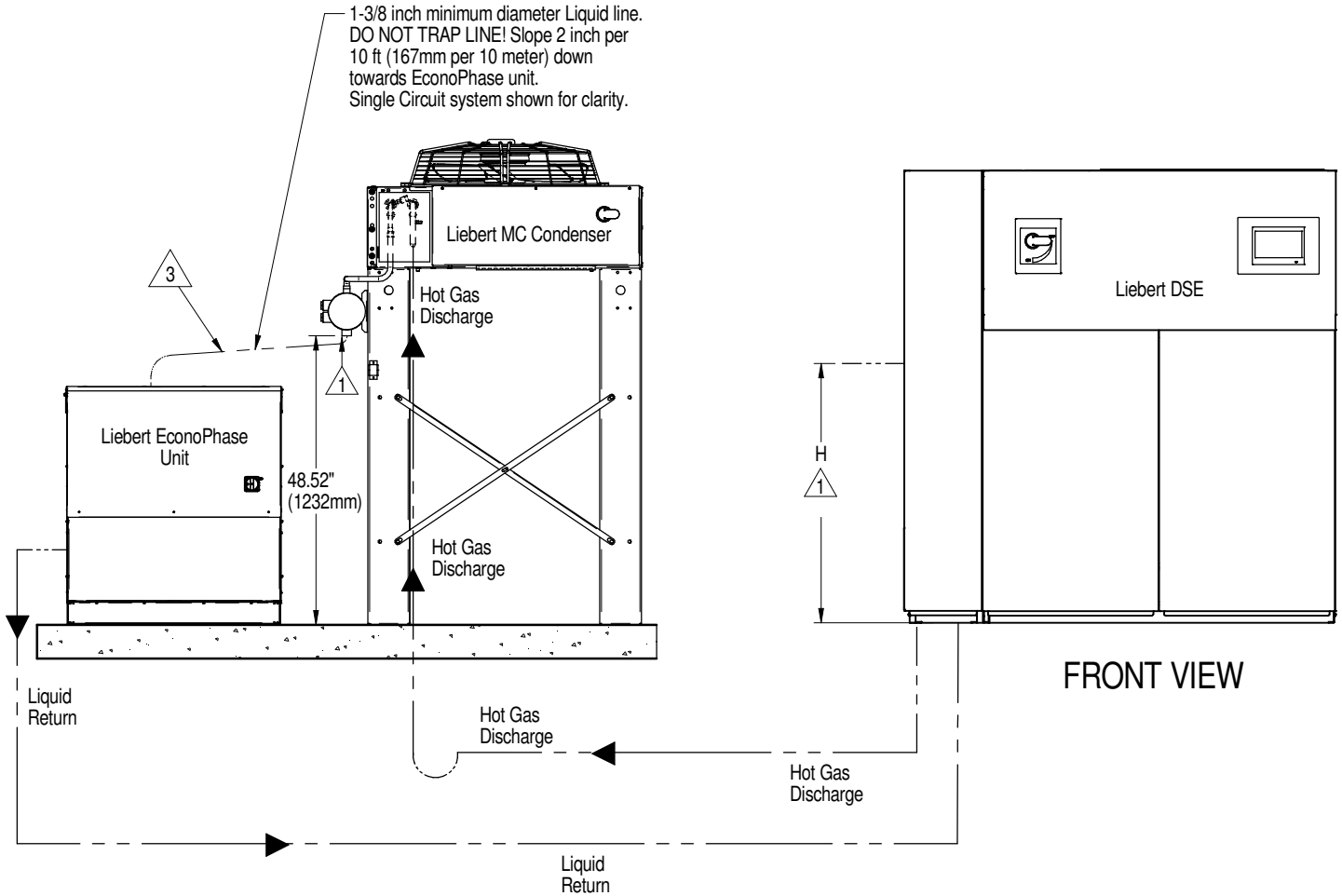

Internal EEV Height	H inch ( mm)
DA050-165	43 ( 1092)

Field Piping

Notes:

1. The outlet of the receiver must be higher than the elevation of the EEV inside the indoor unit.
2. For proper pump function, a minimum elevation difference of 60 inch (1524 mm) must be maintained between the bottom of condenser coil to the bottom of EconoPhase unit.
3. The maximum equivalent piping between the Liebert MC Condenser and EconoPhase unit is 25 ft (7.6 m). EconoPhase unit must be mounted outdoors for proper operation.
4. Unit must be trapped at bottom of riser with any rise over 5 feet (1.5m) high. If rise exceeds 25 feet (7.5m), then a trap is required in 20 foot (6.1m) increments or evenly divided.
5. Pitch horizontal hot gas piping at a minimum of 1/2" per 10 feet (42 mm per 10m) so that gravity will aid in moving oil in the direction of the refrigeration flow.
6. Unit piping entrance varies by unit and may be through the top of the unit.
7. All indoor and outdoor field refrigerant piping must be insulated, 1/2 inch minimum. All outdoor insulation must be UV and ozone resistant.
8. Consult factory for any exceptions to the above guidelines.



## ELECTRICAL FIELD CONNECTIONS PR050 SINGLE CIRCUIT MODELS

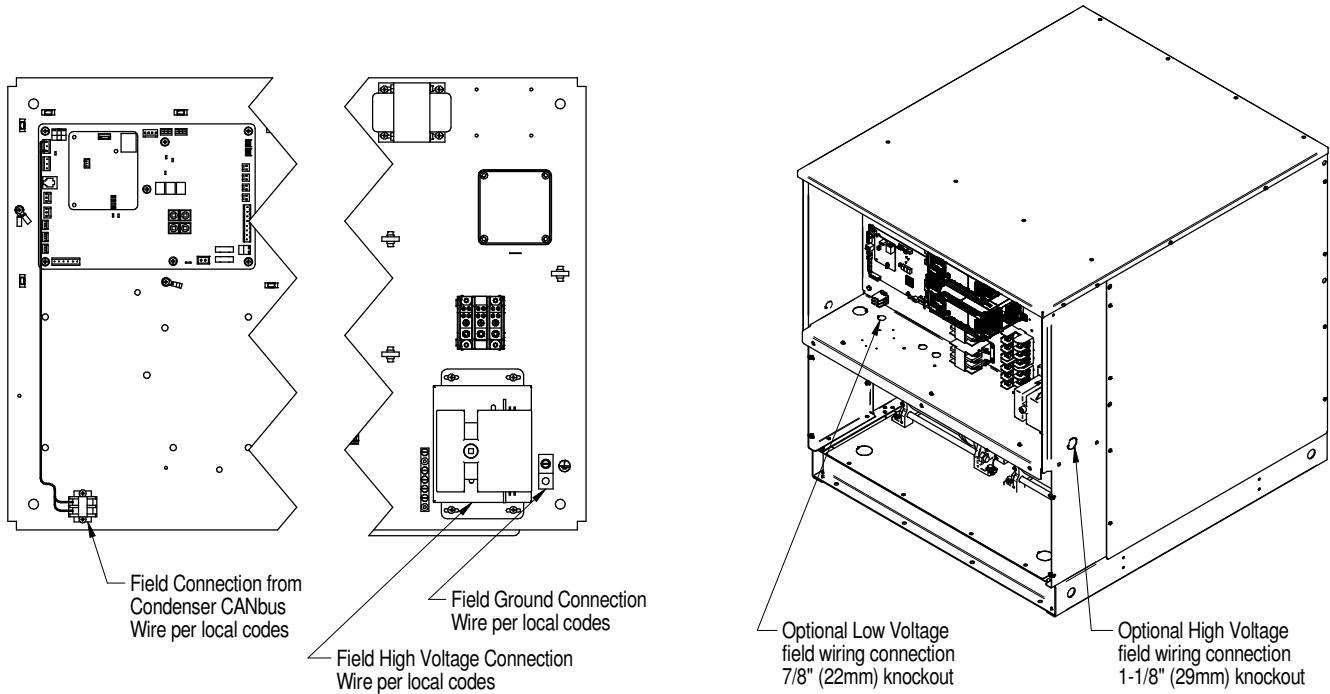

Model	Unit Electrical Specifications						Single Pump Motor		
	Voltage	Phase	Hz	FLA	Minimum Supply Circuit Ampacity	Maximum Fuse Size	HP	FLA	
PR050AA***_	460	3	60	3.5	4.4	15	1.6	3.5	
PR050AY***_	208/230			6.9	8.6			6.9	
PR050AB***_	575			2.8	3.5			3.5	
PR050A2***_	380			4.2	5.3			4.2	
PR050AG***_	415		50	3.7	4.7		1.2	3.7	
PR050AA***H	460		60	0.75	1.3		1.6	0.75	1.3
PR050AY***H	208/230				2.6		3.3		2.6
PR050AB***H	575				1		1.3		1.3
PR050A2***H	380				1.6		2		1.6
PR050AG***H	415				50		1.2		1.5

## PIPING SCHEMATIC DA125, DA150, DA165 & DA250 with LIEBERT MCV

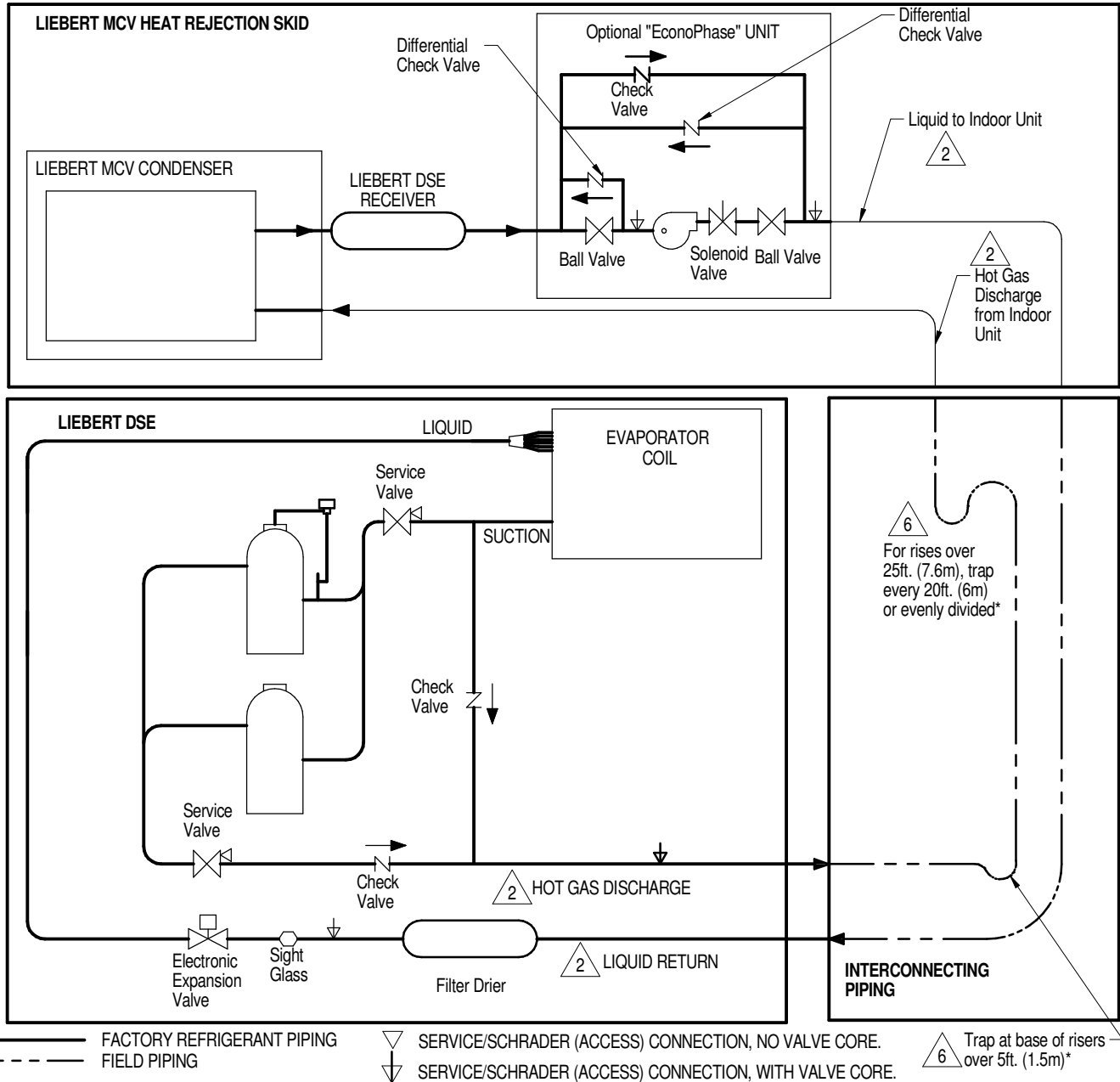

**Notes:**

1. Two refrigeration circuits provided. Single refrigeration circuit shown for clarity.
2. Circuit 1 must be maintained between indoor unit, condenser and EconoPhase unit. Circuit 2 must be maintained between indoor unit, condenser and EconoPhase unit.
3. Schematic representation shown. Do not use for specific connection locations.
4. The outlet of the receiver must be higher than the elevation of the EEV inside the indoor unit. This vertical height must not exceed 60ft. (18.3m). Liebert DSE Receiver required for systems with or without EconoPhase unit.
5. All indoor and outdoor field refrigerant piping must be insulated, 1/2" minimum thickness. All outdoor insulation must be UV and ozone resistant.
6. Components are not supplied by Liebert but are required for proper circuit operation and maintenance (DA250 with top piping has internally installed traps on the discharge lines).
7. Traps must be installed and horizontal lines pitched to ensure proper oil return and to reduce liquid flood back to compressor. Pitch horizontal gas piping at a minimum of 1/2" per 10 feet (42mm per 10m) so that gravity will aid in moving oil in the direction of the refrigeration flow.
8. Do not isolate any refrigeration circuits from over pressurization protection.





---

Vertiv.com | Vertiv Headquarters, 1050 Dearborn Drive, Columbus, OH, 43085, USA

© 2019 Vertiv Group Corp. All rights reserved. Vertiv and the Vertiv logo are trademarks or registered trademarks of Vertiv Group Corp. All other names and logos referred to are trade names, trademarks or registered trademarks of their respective owners. While every precaution has been taken to ensure accuracy and completeness herein, Vertiv Group Corp. assumes no responsibility, and disclaims all liability, for damages resulting from use of this information or for any errors or omissions. Specifications are subject to change without notice.

SL-18920\_REV8/590-1443-501D