

TOSHIBA

TOSHIBA INTERNATIONAL CORPORATION

UNINTERRUPTIBLE POWER SYSTEMS

4400 Series



POWER
ELECTRONICS

NEXT GENERATION TECHNOLOGY

The Toshiba 4400 Series Uninterruptible Power Supply (UPS) is the next-generation three-phase UPS. The double-conversion, all insulated-gate bipolar transistor (IGBT) 4400 Series UPS features a digitally controlled IGBT input rectifier; an intelligent, low harmonic, pulse-width modulation (PWM) IGBT output inverter; state-of-the art, IGBT battery isolation circuitry; and an easy to navigate local touchscreen interface. The small footprint and total front access mechanical design requires zero rear clearance and includes features such as top, bottom, and side cable entry, standard sized air filters included, and lockable keyed doors. Customization is available through a number of options, such as internal battery backup, internal maintenance bypass, internal transformers for specific voltage applications, and remote monitoring with the Toshiba RemotEye® 4 multi-protocol UPS monitoring solution.

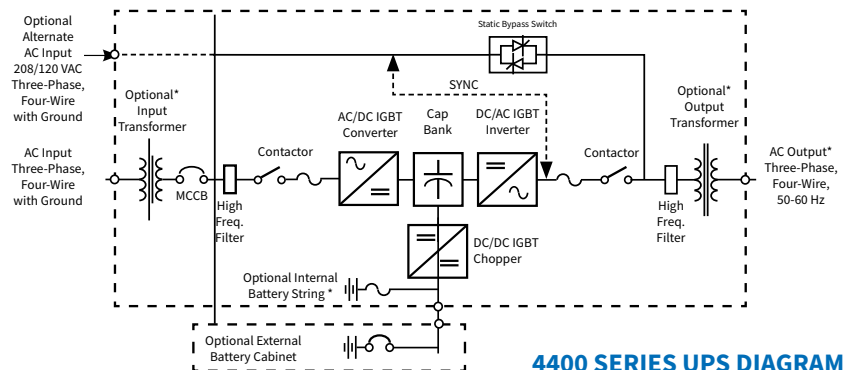

4400 SERIES UPS DIAGRAM

<p>Multi-Application Ready</p>	<p>UPS models available for any application; everything from internal energy storage, internal maintenance bypass, frequency conversion, Power Conditioning (no batteries) or any voltage / power distribution configuration, all in a sleek standardized line up.</p>
<p>Time-Tested Topology</p>	<p>Utilizes a Toshiba established true-online, double conversion all IGBT topology to meet the highest industry standards of reliability and power quality.</p>
<p>Over Design Protection</p>	<p>15 year design life components with long MTBF require minimal service for long lasting use in the toughest of environments.</p>
<p>Bad Utility Responsive, Tough Load Ready</p>	<p>Superior Design features Low Harmonic Distortion, wide input Voltage and frequency window, 100% Load Step and 100% unbalanced load capabilities, with up to 109% continuous overload without compromising voltage regulation.</p>
<p>Value-Generating Construction</p>	<p>Save on power and space with the 4400 Series, rugged industrial all front access, zero rear or side clearance, seismic ready design that minimizes footprint while maximizing power efficiency.</p>
<p>Toshiba End-to-End Solution</p>	<p>Configurable UPS options with wide range of run time Battery cabinets ensure the 4400 Series can represent a turnkey solution for a wide variety of applications.</p>
<p>Made in USA</p>	<p>Manufactured in Houston, Texas. Meets BAA and ARRA requirements.</p>

OPTIONS & ACCESSORIES

BATTERY CABINETS

Matching battery cabinets with Valve-Regulated Lead Acid (VRLA) batteries provide uniform installation appearance with various run times. The Toshiba 4400 Series UPS works equally well with either VRLA or flooded-cell battery backup.

AUXILIARY CABINETS

Matching auxiliary cabinets are available for uniform installation appearance. Options include:

- Maintenance Bypass Switch (MBS)
- Power Distribution
- Subfeed Breakers
- Input Step Down Transformer
- Slim MBS

UPS MONITORING

RemotEye® 4 offers real-time control, monitoring, and analysis of UPS operation. The quick and easy-to-use software can automatically initiate an orderly shutdown to connected servers to minimize any risk of data loss. RemotEye® 4 also features a first-ever mobile website for monitoring UPS status updates on-the-go. Universal communications protocols compatible with RemotEye® 4 include:

- Modbus TCP & RTU
- BACnet IP & MSTP
- HTTP/HTTPS
- SNMP
- IPv6 Compatible

EMERGENCY LIGHTING (UL924)

4400 Series UPS Systems may be ordered in a pre-designed and certified configuration to meet the rigorous UL924 Standard for emergency lighting applications. The end-to-end solution includes the 90-minute runtime and battery test function required by the UL924 Standard. The 4400 Series' centralized approach for emergency lighting is ideal for a world moving towards the utilization of LED lights which demand the power quality that only a UPS system like the 4400 Series can provide. Optional matching 4400 Series Distribution cabinets are available for multi branch circuitry of an Emergency Lighting System.



Battery Cabinet

50-100 kVA UPS

Slim MBS

One Cabinet Solution:
UPS, MBS, & Batteries

INDUSTRIES SERVED

- Data Center
- Emergency/Healthcare
- Commercial/Retail

4400 SERIES APPLICATIONS

- Computer Systems
- Medical Labs
- Small Scale Server Rooms
- Voice/Data Network Closets
- Edge Data Centers
- Point of Sale Equipment
- Banking Systems
- Retail Office Systems
- School System Computer Rooms
- Light Industrial

MODEL NUMBER	4400X3X150XA	4400X3X200XA	4400X3X250XA	4400X3X300XA	4400X3X500XA	4400X3X800XA	4400F3F10KXA
Capacity	15 kVA (13.5 kW)	20 kVA (18 kW)	25 kVA (22.5 kW)	30 kVA (27 kW)	50 kVA (45 kW)	80 kVA (72 kW)	100 kVA (90 kW)
Topology	True On-Line, Double-Conversion, All-IGBT Technology						
INPUT							
Voltage (Standard)	208/120V Three-Phase, Four-Wire + Ground Single or Dual Input*						
Voltage Range	-15% to +10% (Without Using Battery)**					-10% to +10% (Without Using Battery)**	
Power Factor	>0.98						
Current THD	<5% at 100% Load						
Frequency	50 +/- 5 Hz; 60 +/- 5 Hz						
OUTPUT							
Voltage (Standard)	208/120V Three-Phase, Four-Wire + Ground Output***						
Frequency	50/60 Hz, +0.1% Auto-Sensing Standard. (50/60 Hz Selectable, for use as Frequency Converter)						
Voltage Regulation	+/-2% at 0-100% Balanced Load						
Power Factor	0.9 Lagging						
Inverter Overload Capacity	109% Continuous, 110-124% for 6 Minutes, 125-149% for 90 Seconds, 150% for 30 Seconds;					104% Continuous, 105-125% for 6 Minutes, 125-149% for 60 Seconds, 150% for 30 Seconds	
Bypass Overload Capacity	125% for 10 Minutes, 150% for 2 Minutes, 1000% for 1 Cycle						
BATTERY							
DC Link	288 VDC						
Ripple Voltage	<0.5% DC						
ENVIRONMENT							
Temperature Range	32° to 104°F (0° to 40°C)						
Relative Humidity	5% to 95% Non-Condensing						
Heat Rejection	4556 BTUs/Hour	6074 BTUs/Hour	7395 BTUs/Hour	9111 BTUs/Hour	15,286 BTUs/Hour	24,297 BTUs/Hour	30,372 BTUs/Hour
Full-Load Efficiency	91.0%						
25% Load Efficiency	88.0%						
Altitude	3300 ft. (1000 m) Maximum Without Derating						
Air Filtration	Airflow Front-to-Top, Front-Located Filters Included						
Audible Noise	<65dBA @ 1 m Typical					<70dBA @ 1 m Typical	
DIMENSIONS							
Dimensions	20.12 in. (W) x 37.40 in. (D) x 65.06 in. (H)				32.10 in. (W) x 37.20 in. (D) x 73.80 in. (H)		
Weight ****	725 lbs. (329 kg)	730 lbs. (331 kg)	750 lbs. (340 kg)	760 lbs. (345 kg)	965 lbs. (438 kg)	1550 lbs. (612 kg)	1650 lbs. (748 kg)
COLOR							
Powder Coat, DuPont O'Brien Black							
MONITORING							
Touchscreen Operator Interface, UPS Status N/O Dry Contacts, RS232C Interface (Optional RemotEye® 4 Intelligent Monitoring System)							
OPTIONS							
Internal Batteries (15-50kVA), Internal Isolation & Voltage Conversion Transformers, Dual-Input Feed, RemotEye® 4 Intelligent Monitoring System, Remote Status Alarm Panel, External Matching & Non-Matching Battery Cabinets, Matching MBS/Transformer/Distribution Cabinets. UL924 Certified Emergency Lighting System (15-20kVA), Internal 3-Breaker MBS (15-30kVA)							
STANDARDS							
UL 1778, CUL, ISO9001, ISO14001:2004, ANSI C62.41 (IEEE 587), NEMA/PET-1993, CE, IBC, & CBC (OSHDP)						UL 1778, CUL, ISO9001, ISO14001:2004, ANSI C62.41 (IEEE 587), NEMA/PET-1993	
WARRANTY							
3-Year On-Site Warranty; 10+ Year Service Agreements Available; See Toshiba Warranty Policy for Full Details							
SERVICE							
24-Hour, 365-Day Technical Support: 1-877-867-8773							

* Isolation and Auto Transformer Options for Input Voltage Conversion. 15-50kVA Units can support 2 internal transformers. 80kVA Units can support 1 internal transformer. Not available for 100kVA
 ** For loads less than 50% of total UPS output capacity, input voltage within -30% to +10% of Standard value is sufficient for operation
 *** Auto Transformer Options for Output Voltage Conversion. 15-50kVA Units can support 2 internal transformers. 80kVA Units can support 1 internal transformer. Not available for 100kVA
 **** Unit Weight Not Including Internal Battery and Transformers
 Specifications subject to change without notice.



© 2020
 Toshiba International Corporation
 Power Electronics
 13131 West Little York Road
 Houston, Texas 77041 USA
 Tel +713-466-0277
 US 1-800-231-1412
 Rev.10ESSENCE1519

TOSHIBA POWER ELECTRONICS
 Uninterruptible Power Systems • SCiB™ Lithium Ion Batteries • Energy Management Systems
 Remote Monitoring • High Power Chargers • Containerized Solutions
 PDU • RPP • Server Rack Enclosures

www.toshibaups.com

