

Galaxy VX

UPS with 1250 kW I/O Cabinet

Installation

380 V, 400 V, 415 V, 440 V, and 480 V

500 kW/kVA, 500 kW/kVA N+1, 625 kW/kVA, 800 kW/kVA

500 kW/kVA Expandable to 750 kW/kVA, 750 kW/kVA, 750 kW/kVA N+1

500 kW/kVA, 625 kW/kVA, 750 kW/kVA Expandable to 1000 kW/kVA, 1000 kW/kVA, 1000 kW/kVA N+1

1100 kW/kVA, 1100 kW/kVA N+1

500 kW/kVA, 750 kW/kVA, and 1000 kW/kVA Expandable to 1250 kW/kVA, 1250 kW/kVA, 1250 kW/kVA, 1250 kW/kVA N+1

07/2020



Legal Information

The Schneider Electric brand and any trademarks of Schneider Electric SE and its subsidiaries referred to in this guide are the property of Schneider Electric SE or its subsidiaries. All other brands may be trademarks of their respective owners.

This guide and its content are protected under applicable copyright laws and furnished for informational use only. No part of this guide may be reproduced or transmitted in any form or by any means (electronic, mechanical, photocopying, recording, or otherwise), for any purpose, without the prior written permission of Schneider Electric.

Schneider Electric does not grant any right or license for commercial use of the guide or its content, except for a non-exclusive and personal license to consult it on an "as is" basis. Schneider Electric products and equipment should be installed, operated, serviced, and maintained only by qualified personnel.

As standards, specifications, and designs change from time to time, information contained in this guide may be subject to change without notice.

To the extent permitted by applicable law, no responsibility or liability is assumed by Schneider Electric and its subsidiaries for any errors or omissions in the informational content of this material or consequences arising out of or resulting from the use of the information contained herein.

IEC



UL



Go to

IEC: https://www.productinfo.schneider-electric.com/galaxyvx_iec/ or

UL: https://www.productinfo.schneider-electric.com/galaxyvx_ul/

or scan the QR code above for digital experience and translated manuals.

Table of Contents

Important Safety Instructions — SAVE THESE	
INSTRUCTIONS	5
FCC Statement	6
Electromagnetic Compatibility	6
Safety Precautions	6
Electrical Safety	8
Battery Safety	9
Specifications	11
Overview of Configurations	11
Overview of UPSs with 1250 kW I/O Cabinet - Single Utility/ Mains	11
Overview of UPSs with 1250 kW I/O Cabinet - Dual Utility/Mains	12
Specifications for 500 kW UPS	13
Specifications for 625 kW UPS	15
Specifications for 750 kW UPS	17
Specifications for 800 kW UPS	19
Specifications for 1000 kW UPS	21
Specifications for 1100 kW UPS	23
Specifications for 1250 kW UPS	25
Recommended Upstream Protection and Cable Sizes – IEC	26
Recommended Upstream Protection and Cable Sizes – UL	28
Recommended Bolt and Lug Sizes for Copper Cables	31
Recommended Bolt and Lug Sizes for Aluminium Cables	31
Torque Specifications	31
Environment	31
Heat Dissipation (BTU/hr) for UPSs with 1250 kW I/O Cabinet	32
Weights and Dimensions for UPSs with 1250 kW I/O Cabinet	35
Clearance for UPSs with 1250 kW I/O Cabinet	36
Guidance for Organizing Battery Cables	36
Installation Procedure	37
Mechanical Installation	38
Remove the Cabinets from the Pallet	38
Mount the Rear Anchoring Brackets	42
Position the Cabinets	43
Install Busbars between the Power Cabinets	51
Install Busbars between the I/O Cabinet and the Left-Most Power Cabinet	52
Connect the Power Cables	55
Prepare the I/O Cabinet for Power Cables in Top Cable Entry Systems	55
Prepare the I/O Cabinet for Power Cables in Bottom Cable Entry Systems	56
Remove the Single Mains Busbars	58
Connect the Power Cables in a 380/400/415/440 V System	58
Connect the Power Cables in a 480 V System	61
Connect Cables to the External Supply for Li-Ion Battery Solution (Optional)	63

Mount the Front Anchoring Brackets	66
Connect the Signal Cables	67
Connect the Signal Cables between the I/O Cabinet and the Power Cabinets	67
Overview of Board Locations for External Signal Cables	71
Route External Signal Cables to the Boards	72
Final Mechanical Assembly	85
Final Mechanical Assembly of the I/O Cabinet	85
Final Mechanical Assembly of the Power Cabinets	87

Important Safety Instructions — SAVE THESE INSTRUCTIONS

Read these instructions carefully and look at the equipment to become familiar with it before trying to install, operate, service or maintain it. The following safety messages may appear throughout this manual or on the equipment to warn of potential hazards or to call attention to information that clarifies or simplifies a procedure.



The addition of this symbol to a “Danger” or “Warning” safety message indicates that an electrical hazard exists which will result in personal injury if the instructions are not followed.



This is the safety alert symbol. It is used to alert you to potential personal injury hazards. Obey all safety messages with this symbol to avoid possible injury or death.

DANGER

DANGER indicates a hazardous situation which, if not avoided, **will result in death or serious injury.**

Failure to follow these instructions will result in death or serious injury.

WARNING

WARNING indicates a hazardous situation which, if not avoided, **could result in death or serious injury.**

Failure to follow these instructions can result in death, serious injury, or equipment damage.

CAUTION

CAUTION indicates a hazardous situation which, if not avoided, **could result in minor or moderate injury.**

Failure to follow these instructions can result in injury or equipment damage.

NOTICE

NOTICE is used to address practices not related to physical injury. The safety alert symbol shall not be used with this type of safety message.

Failure to follow these instructions can result in equipment damage.

Please Note

Electrical equipment should only be installed, operated, serviced, and maintained by qualified personnel. No responsibility is assumed by Schneider Electric for any consequences arising out of the use of this material.

A qualified person is one who has skills and knowledge related to the construction, installation, and operation of electrical equipment and has received safety training to recognize and avoid the hazards involved.

FCC Statement

NOTE: This equipment has been tested and found to comply with the limits for a Class A digital device, pursuant to Part 15 of the FCC Rules. These limits are designed to provide reasonable protection against harmful interference when the equipment is operated in a commercial environment. This equipment generates, uses, and can radiate radio frequency energy and, if not installed and used in accordance with the instruction manual, may cause harmful interference to radio communications. Operation of this equipment in a residential area is likely to cause harmful interference in which case the user will be required to correct the interference at his own expense.

Any changes or modifications not expressly approved by the party responsible for compliance could void the user's authority to operate the equipment.

Electromagnetic Compatibility

NOTICE

RISK OF ELECTROMAGNETIC DISTURBANCE

This is a product Category C3 according to IEC 62040-2. This is a product for commercial and industrial applications in the second environment - installation restrictions or additional measures may be needed to prevent disturbances. The second environment includes all commercial, light industry, and industrial locations other than residential, commercial, and light industrial premises directly connected without intermediate transformer to a public low-voltage mains supply. The installation and cabling must follow the electromagnetic compatibility rules, e.g.:

- the segregation of cables,
- the use of shielded or special cables when relevant,
- the use of grounded metallic cable tray and supports.

Failure to follow these instructions can result in equipment damage.

Safety Precautions

⚠ DANGER

HAZARD OF ELECTRIC SHOCK, EXPLOSION, OR ARC FLASH

All safety instructions in this document must be read, understood and followed.

Failure to follow these instructions will result in death or serious injury.

⚠ DANGER

HAZARD OF ELECTRIC SHOCK, EXPLOSION, OR ARC FLASH

Read all instructions in the Installation Manual before installing or working on this UPS system.

Failure to follow these instructions will result in death or serious injury.

⚠ DANGER

HAZARD OF ELECTRIC SHOCK, EXPLOSION, OR ARC FLASH

Do not install the UPS system until all construction work has been completed and the installation room has been cleaned.

Failure to follow these instructions will result in death or serious injury.

⚠ DANGER

HAZARD OF ELECTRIC SHOCK, EXPLOSION, OR ARC FLASH

- The product must be installed according to the specifications and requirements as defined by Schneider Electric. It concerns in particular the external and internal protections (upstream breakers, battery breakers, cabling, etc.) and environmental requirements. No responsibility is assumed by Schneider Electric if these requirements are not respected.
- After the UPS system has been electrically wired, do not start up the system. Start-up must only be performed by Schneider Electric.

Failure to follow these instructions will result in death or serious injury.

⚠ DANGER

HAZARD OF ELECTRIC SHOCK, EXPLOSION, OR ARC FLASH

The UPS system must be installed according to local and national regulations. Install the UPS according to:

- IEC 60364 (including 60364-4-41 - protection against electric shock, 60364-4-42 - protection against thermal effect, and 60364-4-43 - protection against overcurrent), **or**
- NEC NFPA 70, **or**
- Canadian Electrical Code (C22.1, Part 1)

depending on which one of the standards apply in your local area.

Failure to follow these instructions will result in death or serious injury.

⚠ DANGER

HAZARD OF ELECTRIC SHOCK, EXPLOSION, OR ARC FLASH

- Install the UPS system in a temperature controlled indoor environment free of conductive contaminants and humidity.
- Install the UPS system on a non-flammable, level and solid surface (e.g. concrete) that can support the weight of the system.

Failure to follow these instructions will result in death or serious injury.

⚠ DANGER**HAZARD OF ELECTRIC SHOCK, EXPLOSION, OR ARC FLASH**

The UPS is not designed for and must therefore not be installed in the following unusual operating environments:

- Damaging fumes
- Explosive mixtures of dust or gases, corrosive gases, or conductive or radiant heat from other sources
- Moisture, abrasive dust, steam or in an excessively damp environment
- Fungus, insects, vermin
- Salt-laden air or contaminated cooling refrigerant
- Pollution degree higher than 2 according to IEC 60664-1
- Exposure to abnormal vibrations, shocks, and tilting
- Exposure to direct sunlight, heat sources, or strong electromagnetic fields

Failure to follow these instructions will result in death or serious injury.

⚠ DANGER**HAZARD OF ELECTRIC SHOCK, EXPLOSION, OR ARC FLASH**

Do not drill or cut holes for cables or conduits with the gland plates installed and do not drill or cut holes in close proximity to the UPS.

Failure to follow these instructions will result in death or serious injury.

⚠ WARNING**HAZARD OF ARC FLASH**

Do not make mechanical changes to the product (including removal of cabinet parts or drilling/cutting of holes) that are not described in the Installation Manual.

Failure to follow these instructions can result in death, serious injury, or equipment damage.

NOTICE**RISK OF OVERHEATING**

Respect the space requirements around the UPS system and do not cover the product's ventilation openings when the UPS system is in operation.

Failure to follow these instructions can result in equipment damage.

NOTICE**RISK OF EQUIPMENT DAMAGE**

Do not connect the UPS output to regenerative load systems including photovoltaic systems and speed drives.

Failure to follow these instructions can result in equipment damage.

Electrical Safety

This manual contains important safety instructions that should be followed during the installation and maintenance of the UPS system.

⚠️⚠️ DANGER

HAZARD OF ELECTRIC SHOCK, EXPLOSION, OR ARC FLASH

- Electrical equipment must be installed, operated, serviced, and maintained only by qualified personnel.
- Apply appropriate personal protective equipment (PPE) and follow safe electrical work practices.
- Disconnection devices for AC and DC must be provided by others, be readily accessible, and the function of the disconnect device marked for its function.
- Turn off all power supplying the UPS system before working on or inside the equipment.
- Before working on the UPS system, check for hazardous voltage between all terminals including the protective earth.
- The UPS contains an internal energy source. Hazardous voltage can be present even when disconnected from the mains supply. Before installing or servicing the UPS system, ensure that the units are OFF and that mains and batteries are disconnected. Wait five minutes before opening the UPS to allow the capacitors to discharge.
- The UPS must be properly earthed/grounded and due to a high leakage current, the earthing/grounding conductor must be connected first.

Failure to follow these instructions will result in death or serious injury.

When the UPS input is connected through external isolators that, when opened, isolate the neutral or when the automatic backfeed isolation is provided external to the equipment or is connected to an IT power distribution system, a label must be fitted at the UPS input terminals, and on all primary power isolators installed remotely from the UPS area and on external access points between such isolators and the UPS, by the user, displaying the following text (or equivalent in a language which is acceptable in the country in which the UPS system is installed):

⚠️⚠️ DANGER

HAZARD OF ELECTRIC SHOCK, EXPLOSION, OR ARC FLASH

Risk of voltage backfeed. Before working on this circuit: Isolate the UPS and check for hazardous voltage between all terminals including the protective earth.

Failure to follow these instructions will result in death or serious injury.

Battery Safety

⚠️⚠️ DANGER

HAZARD OF ELECTRIC SHOCK, EXPLOSION, OR ARC FLASH

- Battery circuit breakers must be installed according to the specifications and requirements as defined by Schneider Electric.
- Servicing of batteries must only be performed or supervised by qualified personnel knowledgeable of batteries and the required precautions. Keep unqualified personnel away from batteries.
- Disconnect charging source prior to connecting or disconnecting battery terminals.
- Do not dispose of batteries in a fire as they can explode.
- Do not open, alter, or mutilate batteries. Released electrolyte is harmful to the skin and eyes. It may be toxic.

Failure to follow these instructions will result in death or serious injury.

⚡⚠ DANGER**HAZARD OF ELECTRIC SHOCK, EXPLOSION, OR ARC FLASH**

Batteries can present a risk of electric shock and high short-circuit current. The following precautions must be observed when working on batteries

- Remove watches, rings, or other metal objects.
- Use tools with insulated handles.
- Wear protective glasses, gloves and boots.
- Do not lay tools or metal parts on top of batteries.
- Disconnect the charging source prior to connecting or disconnecting battery terminals.
- Determine if the battery is inadvertently grounded. If inadvertently grounded, remove source from ground. Contact with any part of a grounded battery can result in electric shock. The likelihood of such shock can be reduced if such grounds are removed during installation and maintenance (applicable to equipment and remote battery supplies not having a grounded supply circuit).

Failure to follow these instructions will result in death or serious injury.

⚡⚠ DANGER**HAZARD OF ELECTRIC SHOCK, EXPLOSION, OR ARC FLASH**

When replacing batteries, always replace with the same type and number of batteries or battery packs.

Failure to follow these instructions will result in death or serious injury.

NOTICE**RISK OF EQUIPMENT DAMAGE**

- Wait until the system is ready to be powered up before installing batteries in the system. The time duration from battery installation until the UPS system is powered up must not exceed 72 hours or 3 days.
- Batteries must not be stored more than six months due to the requirement of recharging. If the UPS system remains de-energized for a long period, Schneider Electric recommends that you energize the UPS system for a period of 24 hours at least once every month. This charges the batteries, thus avoiding irreversible damage.

Failure to follow these instructions can result in equipment damage.

Specifications

Overview of Configurations

Breakers in the System

UIB	Unit input breaker
SSIB	Static switch input breaker
BB	Battery breaker
MBB	Maintenance bypass breaker
UOB	Unit output breaker
BF2	Backfeed protection switch

Overview of UPSs with 1250 kW I/O Cabinet - Single Utility/Mains

The illustration shows a 750 kW UPS. The principle is the same for the other UPSs with the 1250 kW I/O cabinet.

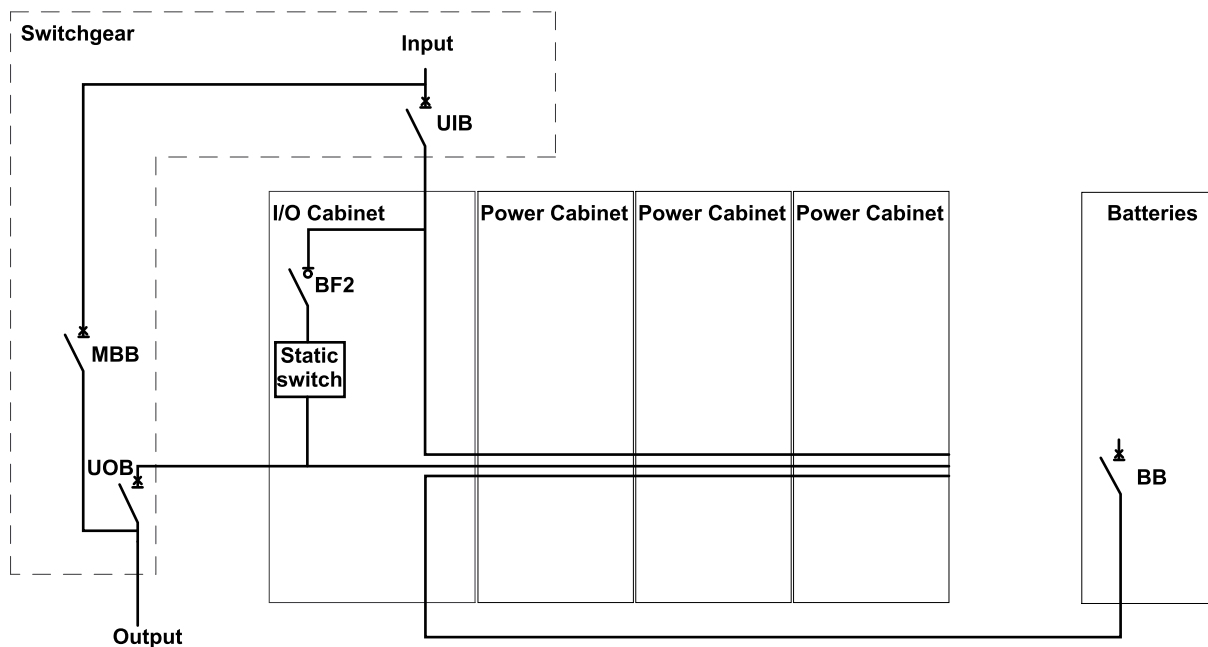

Overview of UPSs with 1250 kW I/O Cabinet - Dual Utility/Mains

The illustration shows a 750 kW UPS. The principle is the same for the other UPSs with the 1250 kW I/O cabinet.

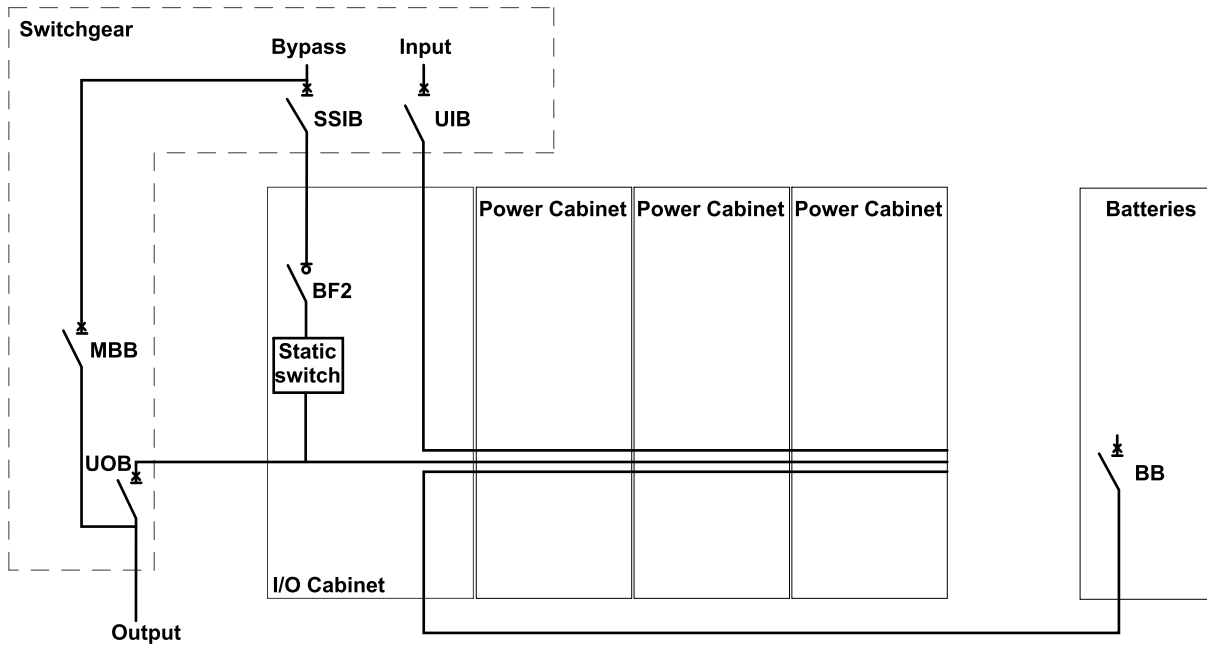

Specifications for 500 kW UPS

	Voltage (V)	380	400	415	440 V	480 V
Input Specifications	Connections	IEC: L1, L2, L3, PE ¹ UL: L1, L2, L3 + G ²				
	Input voltage range (V) ³	340-456	340-480	353-498	374-528	408-576
	Frequency (Hz)	40-70				
	Nominal input current (A)	800	760	731	685	633
	Maximum input current (A) ⁴	886	851	819	767	728
	Input current limitation (A)	890			832	760
	Total harmonic distortion (THDI)	<3% at 100% load, <4% at 50% load, <9% at 25% load				
	Input power factor	0.99 at >40% load, 0.98 at >20% load, 0.97 at >10% load				
	Protection	Contactors				
	Ramp-in	Adaptive 1-300 seconds				
Bypass Specifications	Connections	IEC: L1, L2, L3, N, PE or L1, L2, L3, PE ⁵ UL: L1, L2, L3, G or L1, L2, L3, N, G				
	Bypass voltage range (V)	342-418	360-440	374-457	396-484	432-528
	Frequency (Hz)	50 or 60				
	Frequency range (Hz)	Programmable: ±0.1, ±3, ±10. Default is ±3				
	Nominal bypass current (A)	767	729	703	663	606
	Maximum short circuit rating	100 kA RMS (conditioned by an internal molded switch with 90 kA peak magnetic trip)				
	Thyristor I ² t (kA*s ²)	9680 (1250 kW I/O) 16245 (1500 kW I/O)				9165 (1250 kW I/O) 16245 (1500 kW I/O)
	BF2 magnetic trip	39 kA				
	Protection	Molded switch with trip for backfeed protection				
	Output Specifications	Connections	IEC: L1, L2, L3, N, PE or L1, L2, L3, PE UL: L1, L2, L3, G, GEC ⁶ or L1, L2, L3, N, G			
Overload capacity		Normal operation: 150% for 1 minute, 125% for 10 minutes Battery operation: 115% for 1 minute Bypass operation: 110% ⁷ continuous, 1000% for 60 milliseconds for systems with 1250 kW I/O cabinet and 100 milliseconds for systems with 1500 kW I/O cabinet				
Output voltage tolerance		Balanced load: ±1%, Unbalanced load: ±3%				
Dynamic load response		±5% after 2 ms, ±1% after 50 ms				
Output power factor		1				
Nominal output current (A)		760	722	696	656	601
Total harmonic distortion (THDU)		<2% at 100% linear load, <3% at 100% non-linear load				
Output frequency (Hz)		50/60 (synchronized to bypass), 50/60 Hz ±0.1% (free-running)				
Slew rate (Hz/sec)		Programmable: 0.25, 0.5, 1, 2, 4, 6				
Output performance classification (according to IEC/ EN62040-3)		Double-conversion: VFI-SS-111				
Load crest factor		Up to 3 (THDU < 5%)				
Load power factor	0.7 leading to 0.5 lagging without derating					

1. TN, TT, and IT power distribution systems are supported.
2. WYE source – solid grounded and high resistance grounded sources are supported. Corner (line) grounding is not supported.
3. The system can operate at 600 V for 1 minute.
4. At nominal input voltage and full charge.
5. TN, TT, and IT power distribution systems with no earthed line conductors are supported.
6. Per NEC 250.30.
7. 125% for 480 V.

	Voltage (V)	380	400	415	440 V	480 V	
Battery Specifications	Charging power in % of output power	35% at ≤ 80% load, 12% at 100% load				40% at ≤ 80% load, 15% at 100% load	
	Maximum charging power (kW)	60 at 100% load, 175 at <80% load				75 at 100% load, 200 at 80% load	
	Nominal battery voltage (VDC)	480					
	Nominal float voltage (VDC)	546					
	End of discharge voltage (full load) (VDC)	384					
	End of discharge voltage (no load) (VDC)	420					
	Battery current at full load and nominal battery voltage (A)	1090					
	Battery current at full load and minimum battery voltage (A)	1362					
	Maximum battery backup time	Unlimited					
	Temperature compensation (per cell)	-3.3 mV per °C for T ≥ 25 °C, 0 mV per °C for T < 25 °C					
	Ripple current	< 5% C20 (5 minutes backup time)					
	Battery test	Manual/automatic (selectable)					
	Deep discharge protection	Yes					
	Recharge according to battery temperature	Yes					

Specifications for 625 kW UPS

	Voltage (V)	380	400	415	440 V	480 V
Input Specifications	Connections	IEC: L1, L2, L3, PE ⁸ UL: L1, L2, L3 + G ⁹				
	Input voltage range (V) ¹⁰	340-456	340-480	353-498	374-528	408-576
	Frequency (Hz)	40-70				
	Nominal input current (A)	1001	950	914	853	791
	Maximum input current (A) ¹¹	1107	1063	1024	956	910
	Input current limitation (A)	1113			1040	950
	Total harmonic distortion (THDI)	<3% at 100% load, <4% at 50% load, <9% at 25% load				
	Input power factor	0.99 at >40% load, 0.98 at >20% load, 0.97 at >10% load				
	Protection	Contactors				
	Ramp-in	Adaptive 1-300 seconds				
Bypass Specifications	Connections	IEC: L1, L2, L3, N, PE or L1, L2, L3, PE ¹² UL: L1, L2, L3, G or L1, L2, L3, N, G				
	Bypass voltage range (V)	342-418	360-440	374-457	396-484	432-528
	Frequency (Hz)	50 or 60				
	Frequency range (Hz)	Programmable: ±0.1, ±3, ±10. Default is ±3				
	Nominal bypass current (A)	959	911	878	828	757
	Maximum short circuit rating	100 kA RMS (conditioned by an internal molded switch with 90 kA peak magnetic trip)				
	Thyristor I ² t (kA*s ²)	9680 (1250 kW I/O)				9165 (1250 kW I/O)
	BF2 magnetic trip	39 kA				
	Protection	Molded switch with trip for backfeed protection				
Output Specifications	Connections	IEC: L1, L2, L3, N, PE or L1, L2, L3, PE UL: L1, L2, L3, G, GEC ¹³ or L1, L2, L3, N, G				
	Overload capacity	Normal operation: 150% for 1 minute, 125% for 10 minutes Battery operation: 115% for 1 minute Bypass operation: 110% ¹⁴ continuous, 1000% for 60 milliseconds for systems with 1250 kW I/O cabinet and 100 milliseconds for systems with 1500 kW I/O cabinet				
	Output voltage tolerance	Balanced load: ±1%, Unbalanced load: ±3%				
	Dynamic load response	±5% after 2 ms, ±1% after 50 ms				
	Output power factor	1				
	Nominal output current (A)	950	902	870	820	752
	Total harmonic distortion (THDU)	<2% at 100% linear load, <3% at 100% non-linear load				
	Output frequency (Hz)	50/60 (synchronized to bypass), 50/60 Hz ±0.1% (free-running)				
	Slew rate (Hz/sec)	Programmable: 0.25, 0.5, 1, 2, 4, 6				
	Output performance classification (according to IEC/ EN62040-3)	Double-conversion: VFI-SS-111				
	Load crest factor	Up to 3 (THDU < 5%)				
Load power factor	0.7 leading to 0.5 lagging without derating					

8. TN, TT, and IT power distribution systems are supported.
 9. WYE source – solid grounded and high resistance grounded sources are supported. Corner (line) grounding is not supported.
 10. The system can operate at 600 V for 1 minute.
 11. At nominal input voltage and full charge.
 12. TN, TT, and IT power distribution systems with no earthed line conductors are supported.
 13. Per NEC 250.30.
 14. 125% for 480 V.

	Voltage (V)	380	400	415	440 V	480 V
Battery Specifications	Charging power in % of output power	35% at ≤ 80% load, 12% at 100% load				40% at ≤ 80% load, 15% at 100% load
	Maximum charging power (kW)	75 at 100% load, 218.75 at <80% load				93.75 at 100% load, 250 at 80% load
	Nominal battery voltage (VDC)	480				
	Nominal float voltage (VDC)	546				
	End of discharge voltage (full load) (VDC)	384				
	End of discharge voltage (no load) (VDC)	420				
	Battery current at full load and nominal battery voltage (A)	1362				
	Battery current at full load and minimum battery voltage (A)	1703				
	Maximum battery backup time	Unlimited				
	Temperature compensation (per cell)	-3.3 mV per °C for T ≥ 25 °C, 0 mV per °C for T < 25 °C				
	Ripple current	< 5% C20 (5 minutes backup time)				
	Battery test	Manual/automatic (selectable)				
	Deep discharge protection	Yes				
	Recharge according to battery temperature	Yes				

Specifications for 750 kW UPS

	Voltage (V)	380	400	415	440 V	480 V
Input Specifications	Connections	IEC: L1, L2, L3, PE ¹⁵ UL: L1, L2, L3 + G ¹⁶				
	Input voltage range (V) ¹⁷	340-456	340-480	353-498	374-528	408-576
	Frequency (Hz)	40-70				
	Nominal input current (A)	1201	1139	1097	1029	950
	Maximum input current (A) ¹⁸	1328	1276	1229	1153	1092
	Input current limitation (A)	1335			1248	1140
	Total harmonic distortion (THDI)	<3% at 100% load, <4% at 50% load, <9% at 25% load				
	Input power factor	0.99 at >40% load, 0.98 at >20% load, 0.97 at >10% load				
	Protection	Contactors				
	Ramp-in	Adaptive 1-300 seconds				
Bypass Specifications	Connections	IEC: L1, L2, L3, N, PE or L1, L2, L3, PE ¹⁹ UL: L1, L2, L3, G or L1, L2, L3, N, G				
	Bypass voltage range (V)	342-418	360-440	374-457	396-484	432-528
	Frequency (Hz)	50 or 60				
	Frequency range (Hz)	Programmable: ±0.1, ±3, ±10. Default is ±3				
	Nominal bypass current (A)	1151	1093	1054	994	909
	Maximum short circuit rating	100 kA RMS (conditioned by an internal molded switch with 90 kA peak magnetic trip)				
	Thyristor I ² t (kA*s ²)	9680 (1250 kW I/O) 16245 (1500 kW I/O)				9165 (1250 kW I/O) 16245 (1500 kW I/O)
	BF2 magnetic trip	39 kA				
	Protection	Molded switch with trip for backfeed protection				
	Output Specifications	Connections	IEC: L1, L2, L3, N, PE or L1, L2, L3, PE UL: L1, L2, L3, G, GEC ²⁰ or L1, L2, L3, N, G			
Overload capacity		Normal operation: 150% for 1 minute, 125% for 10 minutes Battery operation: 115% for 1 minute Bypass operation: 110% ²¹ continuous, 1000% for 60 milliseconds for systems with 1250 kW I/O cabinet and 100 milliseconds for systems with 1500 kW I/O cabinet				
Output voltage tolerance		Balanced load: ±1%, Unbalanced load: ±3%				
Dynamic load response		±5% after 2 ms, ±1% after 50 ms				
Output power factor		1				
Nominal output current (A)		1140	1083	1043	984	902
Total harmonic distortion (THDU)		<2% at 100% linear load, <3% at 100% non-linear load				
Output frequency (Hz)		50/60 (synchronized to bypass), 50/60 Hz ±0.1% (free-running)				
Slew rate (Hz/sec)		Programmable: 0.25, 0.5, 1, 2, 4, 6				
Output performance classification (according to IEC/ EN62040-3)		Double-conversion: VFI-SS-111				
Load crest factor	Up to 3 (THDU < 5%)					
Load power factor	0.7 leading to 0.5 lagging without derating					

15. TN, TT, and IT power distribution systems are supported.

16. WYE source – solid grounded and high resistance grounded sources are supported. Corner (line) grounding is not supported.

17. The system can operate at 600 V for 1 minute.

18. At nominal input voltage and full charge.

19. TN, TT, and IT power distribution systems with no earthed line conductors are supported.

20. Per NEC 250.30.

21. 125% for 480 V.

	Voltage (V)	380	400	415	440 V	480 V	
Battery Specifications	Charging power in % of output power	35% at ≤ 80% load, 12% at 100% load				40% at ≤ 80% load, 15% at 100% load	
	Maximum charging power (kW)	90 at 100% load, 262 at <80% load				112.5 at 100% load, 300 at 80% load	
	Nominal battery voltage (VDC)	480					
	Nominal float voltage (VDC)	546					
	End of discharge voltage (full load) (VDC)	384					
	End of discharge voltage (no load) (VDC)	420					
	Battery current at full load and nominal battery voltage (A)	1634					
	Battery current at full load and minimum battery voltage (A)	2043					
	Maximum battery backup time	Unlimited					
	Temperature compensation (per cell)	-3.3 mV per °C for T ≥ 25 °C, 0 mV per °C for T < 25 °C					
	Ripple current	< 5% C20 (5 minutes backup time)					
	Battery test	Manual/automatic (selectable)					
	Deep discharge protection	Yes					
	Recharge according to battery temperature	Yes					

Specifications for 800 kW UPS

	Voltage (V)	380	400	415	440 V	480 V
Input Specifications	Connections	IEC: L1, L2, L3, PE ²² UL: L1, L2, L3 + G ²³				
	Input voltage range (V) ²⁴	340-456	340-480	353-498	374-528	408-576
	Frequency (Hz)	40-70				
	Nominal input current (A)	1281	1215	1170	1098	1013
	Maximum input current (A) ²⁵	1417	1361	1311	1230	1165
	Input current limitation (A)	1424			1331	1216
	Total harmonic distortion (THDI)	<3% at 100% load, <4% at 50% load, <9% at 25% load				
	Input power factor	0.99 at >40% load, 0.98 at >20% load, 0.97 at >10% load				
	Protection	Contactors				
	Ramp-in	Adaptive 1-300 seconds				
Bypass Specifications	Connections	IEC: L1, L2, L3, N, PE or L1, L2, L3, PE ²⁶ UL: L1, L2, L3, G or L1, L2, L3, N, G				
	Bypass voltage range (V)	342-418	360-440	374-457	396-484	432-528
	Frequency (Hz)	50 or 60				
	Frequency range (Hz)	Programmable: ±0.1, ±3, ±10. Default is ±3				
	Nominal bypass current (A)	1228	1166	1124	1060	969
	Maximum short circuit rating	100 kA RMS (conditioned by an internal molded switch with 90 kA peak magnetic trip)				
	Thyristor I ² t (kA*s ²)	9680 (1250 kW I/O)				9165 (1250 kW I/O)
	BF2 magnetic trip	39 kA				
	Protection	Molded switch with trip for backfeed protection				
Output Specifications	Connections	IEC: L1, L2, L3, N, PE or L1, L2, L3, PE UL: L1, L2, L3, G, GEC ²⁷ or L1, L2, L3, N, G				
	Overload capacity	Normal operation: 150% for 1 minute, 125% for 10 minutes Battery operation: 115% for 1 minute Bypass operation: 110% ²⁸ continuous, 1000% for 60 milliseconds for systems with 1250 kW I/O cabinet and 100 milliseconds for systems with 1500 kW I/O cabinet				
	Output voltage tolerance	Balanced load: ±1%, Unbalanced load: ±3%				
	Dynamic load response	±5% after 2 ms, ±1% after 50 ms				
	Output power factor	1				
	Nominal output current (A)	1216	1155	1113	1050	962
	Total harmonic distortion (THDU)	<2% at 100% linear load, <3% at 100% non-linear load				
	Output frequency (Hz)	50/60 (synchronized to bypass), 50/60 Hz ±0.1% (free-running)				
	Slew rate (Hz/sec)	Programmable: 0.25, 0.5, 1, 2, 4, 6				
	Output performance classification (according to IEC/ EN62040-3)	Double-conversion: VFI-SS-111				
	Load crest factor	Up to 3 (THDU < 5%)				
Load power factor	0.7 leading to 0.5 lagging without derating					

22. TN, TT, and IT power distribution systems are supported.

23. WYE source – solid grounded and high resistance grounded sources are supported. Corner (line) grounding is not supported.

24. The system can operate at 600 V for 1 minute.

25. At nominal input voltage and full charge.

26. TN, TT, and IT power distribution systems with no earthed line conductors are supported.

27. Per NEC 250.30.

28. 125% for 480 V.

	Voltage (V)	380	400	415	440 V	480 V
Battery Specifications	Charging power in % of output power	35% at ≤ 80% load, 12% at 100% load				40% at ≤ 80% load, 15% at 100% load
	Maximum charging power (kW)	96 at 100% load, 280 at <80% load				120 at 100% load, 320 at 80% load
	Nominal battery voltage (VDC)	480				
	Nominal float voltage (VDC)	546				
	End of discharge voltage (full load) (VDC)	384				
	End of discharge voltage (no load) (VDC)	420				
	Battery current at full load and nominal battery voltage (A)	1743				
	Battery current at full load and minimum battery voltage (A)	2179				
	Maximum battery backup time	Unlimited				
	Temperature compensation (per cell)	-3.3 mV per °C for T ≥ 25 °C, 0 mV per °C for T < 25 °C				
	Ripple current	< 5% C20 (5 minutes backup time)				
	Battery test	Manual/automatic (selectable)				
	Deep discharge protection	Yes				
	Recharge according to battery temperature	Yes				

Specifications for 1000 kW UPS

	Voltage (V)	380	400	415	440 V	480 V
Input Specifications	Connections	IEC: L1, L2, L3, PE ²⁹ UL: L1, L2, L3 + G ³⁰				
	Input voltage range (V) ³¹	340-456	340-480	353-498	374-528	408-576
	Frequency (Hz)	40-70				
	Nominal input current (A)	1601	1519	1463	1370	1266
	Maximum input current (A) ³²	1771	1702	1638	1534	1456
	Input current limitation (A)	1780			1664	1520
	Total harmonic distortion (THDI)	<3% at 100% load, <4% at 50% load, <9% at 25% load				
	Input power factor	0.99 at >40% load, 0.98 at >20% load, 0.97 at >10% load				
	Protection	Contactors				
	Ramp-in	Adaptive 1-300 seconds				
Bypass Specifications	Connections	IEC: L1, L2, L3, N, PE or L1, L2, L3, PE ³³ UL: L1, L2, L3, G or L1, L2, L3, N, G				
	Bypass voltage range (V)	342-418	360-440	374-457	396-484	432-528
	Frequency (Hz)	50 or 60				
	Frequency range (Hz)	Programmable: ±0.1, ±3, ±10. Default is ±3				
	Nominal bypass current (A)	1535	1458	1405	1325	1211
	Maximum short circuit rating	100 kA RMS (conditioned by an internal molded switch with 90 kA peak magnetic trip)				
	Thyristor I ² t (kA*s ²)	9680 (1250 kW I/O) 16245 (1500 kW I/O)				9165 (1250 kW I/O) 16245 (1500 kW I/O)
	BF2 magnetic trip	39 kA				
	Protection	Molded switch with trip for backfeed protection				
	Output Specifications	Connections	IEC: L1, L2, L3, N, PE or L1, L2, L3, PE UL: L1, L2, L3, G, GEC ³⁴ or L1, L2, L3, N, G			
Overload capacity		Normal operation: 150% for 1 minute, 125% for 10 minutes Battery operation: 115% for 1 minute Bypass operation: 110% ³⁵ continuous, 1000% for 60 milliseconds for systems with 1250 kW I/O cabinet and 100 milliseconds for systems with 1500 kW I/O cabinet				
Output voltage tolerance		Balanced load: ±1%, Unbalanced load: ±3%				
Dynamic load response		±5% after 2 ms, ±1% after 50 ms				
Output power factor		1				
Nominal output current (A)		1519	1443	1391	1312	1203
Total harmonic distortion (THDU)		<2% at 100% linear load, <3% at 100% non-linear load				
Output frequency (Hz)		50/60 (synchronized to bypass), 50/60 Hz ±0.1% (free-running)				
Slew rate (Hz/sec)		Programmable: 0.25, 0.5, 1, 2, 4, 6				
Output performance classification (according to IEC/ EN62040-3)		Double-conversion: VFI-SS-111				
Load crest factor		Up to 3 (THDU < 5%)				
Load power factor	0.7 leading to 0.5 lagging without derating					

29. TN, TT, and IT power distribution systems are supported.

30. WYE source – solid grounded and high resistance grounded sources are supported. Corner (line) grounding is not supported.

31. The system can operate at 600 V for 1 minute.

32. At nominal input voltage and full charge.

33. TN, TT, and IT power distribution systems with no earthed line conductors are supported.

34. Per NEC 250.30.

35. 125% for 480 V.

	Voltage (V)	380	400	415	440 V	480 V
Battery Specifications	Charging power in % of output power	35% at ≤ 80% load, 12% at 100% load				40% at ≤ 80% load, 15% at 100% load
	Maximum charging power (kW)	120 at 100% load, 350 at <80% load				150 at 100% load, 400 at <80% load
	Nominal battery voltage (VDC)	480				
	Nominal float voltage (VDC)	546				
	End of discharge voltage (full load) (VDC)	384				
	End of discharge voltage (no load) (VDC)	420				
	Battery current at full load and nominal battery voltage (A)	2179				
	Battery current at full load and minimum battery voltage (A)	2724				
	Maximum battery backup time	Unlimited				
	Temperature compensation (per cell)	-3.3 mV per °C for T ≥ 25 °C, 0 mV per °C for T < 25 °C				
	Ripple current	< 5% C20 (5 minutes backup time)				
	Battery test	Manual/automatic (selectable)				
	Deep discharge protection	Yes				
	Recharge according to battery temperature	Yes				

Specifications for 1100 kW UPS

	Voltage (V)	380	400	415	440 V	480 V
Input Specifications	Connections	IEC: L1, L2, L3, PE ³⁶ UL: L1, L2, L3 + G ³⁷				
	Input voltage range (V) ³⁸	340-456	340-480	353-498	374-528	408-576
	Frequency (Hz)	40-70				
	Nominal input current (A)	1761	1671	1609	1510	1393
	Maximum input current (A) ³⁹	1948	1872	1802	1691	1602
	Input current limitation (A)	1958			1830	1672
	Total harmonic distortion (THDI)	<3% at 100% load, <4% at 50% load, <9% at 25% load				
	Input power factor	0.99 at >40% load, 0.98 at >20% load, 0.97 at >10% load				
	Protection	Contactors				
	Ramp-in	Adaptive 1-300 seconds				
Bypass Specifications	Connections	IEC: L1, L2, L3, N, PE or L1, L2, L3, PE ⁴⁰ UL: L1, L2, L3, G or L1, L2, L3, N, G				
	Bypass voltage range (V)	342-418	360-440	374-457	396-484	432-528
	Frequency (Hz)	50 or 60				
	Frequency range (Hz)	Programmable: ±0.1, ±3, ±10. Default is ±3				
	Nominal bypass current (A)	1688	1604	1546	1458	1332
	Maximum short circuit rating	100 kA RMS (conditioned by an internal molded switch with 90 kA peak magnetic trip)				
	Thyristor I ² t (kA*s ²)	9680 (1250 kW I/O)				9165 (1250 kW I/O)
	BF2 magnetic trip	39 kA				
	Protection	Molded switch with trip for backfeed protection				
Output Specifications	Connections	IEC: L1, L2, L3, N, PE or L1, L2, L3, PE UL: L1, L2, L3, G, GEC ⁴¹ or L1, L2, L3, N, G				
	Overload capacity	Normal operation: 150% for 1 minute, 125% for 10 minutes Battery operation: 115% for 1 minute Bypass operation: 110% ⁴² continuous, 1000% for 60 milliseconds for systems with 1250 kW I/O cabinet and 100 milliseconds for systems with 1500 kW I/O cabinet				
	Output voltage tolerance	Balanced load: ±1%, Unbalanced load: ±3%				
	Dynamic load response	±5% after 2 ms, ±1% after 50 ms				
	Output power factor	1				
	Nominal output current (A)	1671	1588	1530	1443	1323
	Total harmonic distortion (THDU)	<2% at 100% linear load, <3% at 100% non-linear load				
	Output frequency (Hz)	50/60 (synchronized to bypass), 50/60 Hz ±0.1% (free-running)				
	Slew rate (Hz/sec)	Programmable: 0.25, 0.5, 1, 2, 4, 6				
	Output performance classification (according to IEC/ EN62040-3)	Double-conversion: VFI-SS-111				
	Load crest factor	Up to 3 (THDU < 5%)				
Load power factor	0.7 leading to 0.5 lagging without derating					

36. TN, TT, and IT power distribution systems are supported.

37. WYE source – solid grounded and high resistance grounded sources are supported. Corner (line) grounding is not supported.

38. The system can operate at 600 V for 1 minute.

39. At nominal input voltage and full charge.

40. TN, TT, and IT power distribution systems with no earthed line conductors are supported.

41. Per NEC 250.30.

42. 125% for 480 V.

	Voltage (V)	380	400	415	440 V	480 V
Battery Specifications	Charging power in % of output power	35% at ≤ 80% load, 12% at 100% load				40% at ≤ 80% load, 15% at 100% load
	Maximum charging power (kW)	132 at 100% load, 385 at <80% load				165 at 100% load, 440 at <80% load
	Nominal battery voltage (VDC)	480				
	Nominal float voltage (VDC)	546				
	End of discharge voltage (full load) (VDC)	384				
	End of discharge voltage (no load) (VDC)	420				
	Battery current at full load and nominal battery voltage (A)	2397				
	Battery current at full load and minimum battery voltage (A)	2996				
	Maximum battery backup time	Unlimited				
	Temperature compensation (per cell)	-3.3 mV per °C for T ≥ 25 °C, 0 mV per °C for T < 25 °C				
	Ripple current	< 5% C20 (5 minutes backup time)				
	Battery test	Manual/automatic (selectable)				
	Deep discharge protection	Yes				
	Recharge according to battery temperature	Yes				

Specifications for 1250 kW UPS

	Voltage (V)	380	400	415	440 V	480 V
Input Specifications	Connections	IEC: L1, L2, L3, PE ⁴³ UL: L1, L2, L3 + G ⁴⁴				
	Input voltage range (V) ⁴⁵	340-456	340-480	353-498	374-528	408-576
	Frequency (Hz)	40-70				
	Nominal input current (A)	2001	1899	1828	1716	1583
	Maximum input current (A) ⁴⁶	2214	2127	2048	1922	1820
	Input current limitation (A)	2225			2080	1900
	Total harmonic distortion (THDI)	<3% at 100% load, <4% at 50% load, <9% at 25% load				
	Input power factor	0.99 at >40% load, 0.98 at >20% load, 0.97 at >10% load				
	Protection	Contactors				
	Ramp-in	Adaptive 1-300 seconds				
Bypass Specifications	Connections	IEC: L1, L2, L3, N, PE or L1, L2, L3, PE ⁴⁷ UL: L1, L2, L3, G or L1, L2, L3, N, G				
	Bypass voltage range (V)	342-418	360-440	374-457	396-484	432-528
	Frequency (Hz)	50 or 60				
	Frequency range (Hz)	Programmable: ±0.1, ±3, ±10. Default is ±3				
	Nominal bypass current (A)	1918	1822	1757	1657	1514
	Maximum short circuit rating	100 kA RMS (conditioned by an internal molded switch with 90 kA peak magnetic trip)				
	Thyristor I ² t (kA*s ²)	9680 (1250 kW I/O) 16245 (1500 kW I/O)				9165 (1250 kW I/O) 16245 (1500 kW I/O)
	BF2 magnetic trip	39 kA				
	Protection	Molded switch with trip for backfeed protection				
	Output Specifications	Connections	IEC: L1, L2, L3, N, PE or L1, L2, L3, PE UL: L1, L2, L3, G, GEC ⁴⁸ or L1, L2, L3, N, G			
Overload capacity		Normal operation: 150% for 1 minute, 125% for 10 minutes Battery operation: 115% for 1 minute Bypass operation: 110% ⁴⁹ continuous, 1000% for 60 milliseconds for systems with 1250 kW I/O cabinet and 100 milliseconds for systems with 1500 kW I/O cabinet				
Output voltage tolerance		Balanced load: ±1%, Unbalanced load: ±3%				
Dynamic load response		±5% after 2 ms, ±1% after 50 ms				
Output power factor		1				
Nominal output current (A)		1899	1804	1739	1640	1504
Total harmonic distortion (THDU)		<2% at 100% linear load, <3% at 100% non-linear load				
Output frequency (Hz)		50/60 (synchronized to bypass), 50/60 Hz ±0.1% (free-running)				
Slew rate (Hz/sec)		Programmable: 0.25, 0.5, 1, 2, 4, 6				
Output performance classification (according to IEC/ EN62040-3)		Double-conversion: VFI-SS-111				
Load crest factor	Up to 3 (THDU < 5%)					
Load power factor	0.7 leading to 0.5 lagging without derating					

43. TN, TT, and IT power distribution systems are supported.

44. WYE source – solid grounded and high resistance grounded sources are supported. Corner (line) grounding is not supported.

45. The system can operate at 600 V for 1 minute.

46. At nominal input voltage and full charge.

47. TN, TT, and IT power distribution systems with no earthed line conductors are supported.

48. Per NEC 250.30.

49. 125% for 480 V.

Voltage (V)		380	400	415	440 V	480 V
Battery Specifications	Charging power in % of output power	35% at ≤ 80% load, 12% at 100% load				40% at ≤ 80% load, 15% at 100% load
	Maximum charging power (kW)	150 at 100% load, 437 at <80% load				187.5 at 100% load, 500 at <80% load
	Nominal battery voltage (VDC)	480				
	Nominal float voltage (VDC)	546				
	End of discharge voltage (full load) (VDC)	384				
	End of discharge voltage (no load) (VDC)	420				
	Battery current at full load and nominal battery voltage (A)	2724				
	Battery current at full load and minimum battery voltage (A)	3405				
	Maximum battery backup time	1 hour				
	Temperature compensation (per cell)	-3.3 mV per °C for T ≥ 25 °C, 0 mV per °C for T < 25 °C				
	Ripple current	< 5% C20 (5 minutes backup time)				
	Battery test	Manual/automatic (selectable)				
	Deep discharge protection	Yes				
	Recharge according to battery temperature	Yes				

Recommended Upstream Protection and Cable Sizes – IEC

⚠ DANGER

HAZARD OF ELECTRIC SHOCK, EXPLOSION, OR ARC FLASH

An easily accessible breaker is required for upstream protection. Maximum fault current disconnection time: 46 seconds at 200% input.

Failure to follow these instructions will result in death or serious injury.

NOTE: Overcurrent protection is to be provided by others.

Cable sizes in this manual are based on table B.52.12 and B.52.13 of IEC 60364-5-52 with the following assertions:

- 90 °C conductors
- An ambient temperature of 30 °C
- Use of copper or aluminium conductors
- Installation method F4 for DC cables and installation method F5 for AC cables, corrected for single layer in perforated cable tray.

PE cables are sized in accordance with IEC 60364-5-54 table 54.2 Minimum cross-sectional area of protective conductors.

NOTE: Always consider the PE size according to the complete electrical installation.

If the ambient temperature is greater than 30 °C, larger conductors are to be selected in accordance with the correction factors of the IEC.

NOTE: The use of aluminium conductors can limit the number of parallel Li-ion battery cabinets. Please contact Schneider Electric for more information.

Recommended Upstream Protection and Cable Sizes for 500 kW UPS

Voltage (V)	Maximum OCPD (A)				Conductors per Phase Copper/ Aluminium (mm ²)				PE Conductor (mm ²)			
	380	400	415	440	380	400	415	440	380	400	415	440
Input	1000 <i>I_r</i> =0.90	1000 <i>I_r</i> =0.90	1000 <i>I_r</i> =0.90	1000 <i>I_r</i> =0.90	2x240/ 3x185	2x240/ 3x185	2x240/ 3x185	2x240/ 3x185	1x240/ 2x150	1x240/ 2x150	1x240/ 2x150	1x240/ 2x150
Bypass	800 <i>I_r</i> =0.98	800 <i>I_r</i> =0.95	800 <i>I_r</i> =0.9	800 <i>I_r</i> =0.9	2x185/ 2x240	2x150/ 2x240	2x150/ 2x240	2x150/ 2x240	1x185/ 1x240	1x150/ 1x240	1x150/ 1x240	1x150/ 1x240
Output	800 <i>I_r</i> =0.98	800 <i>I_r</i> =0.95	800 <i>I_r</i> =0.9	800 <i>I_r</i> =0.9	2x185/ 2x240	2x150/ 2x240	2x150/ 2x240	2x150/ 2x240	1x185/ 1x240	1x150/ 1x240	1x150/ 1x240	1x150/ 1x240
Battery	1500	1500	1500	1500	3x185/ 3x240	3x185/ 3x240	3x185/ 3x240	3x185/ 3x240	2x150/ 2x185	2x150/ 2x185	2x150/ 2x185	2x150/ 2x185

Recommended Upstream Protection and Cable Sizes for 625 kW UPS

	Maximum OCPD (A)				Conductors per Phase Copper/ Aluminium (mm ²)				PE Conductor (mm ²)			
	380 V	400 V	415 V	440 V	380 V	400 V	415 V	440 V	380 V	400 V	415 V	440 V
Input	1250 <i>I_r</i> =0.9	1250 <i>I_r</i> =0.9	1250 <i>I_r</i> =0.9	1250 <i>I_r</i> =0.9	3x185/ 3x240	3x185/ 3x240	3x185/ 3x240	3x185/ 3x240	2x150/ 2x185	2x150/ 2x185	2x150/ 2x185	2x150/ 2x185
Bypass	1000 <i>I_r</i> =0.98	1000 <i>I_r</i> =0.95	1000 <i>I_r</i> =0.9	1000 <i>I_r</i> =0.9	2x240/ 3x240	2x240/ 3x185	2x240/ 3x185	2x240/ 3x185	1x240/ 2x185	1x240/ 2x150	1x240/ 2x150	1x240/ 2x150
Output	1000 <i>I_r</i> =0.98	1000 <i>I_r</i> =0.95	1000 <i>I_r</i> =0.9	1000 <i>I_r</i> =0.9	2x240/ 3x240	2x240/ 3x185	2x240/ 3x185	2x240/ 3x185	1x240/ 2x185	1x240/ 2x150	1x240/ 2x150	1x240/ 2x150
Battery	2000	2000	2000	2000	3x240/ 4x240	3x240/ 4x240	3x240/ 4x240	3x240/ 4x240	2x185/ 2x240	2x185/ 2x240	2x185/ 2x240	2x185/ 2x240

Recommended Upstream Protection and Cable Sizes for 750 kW UPS

Voltage (V)	Maximum OCPD (A)				Conductors per Phase Copper/ Aluminium (mm ²)				PE Conductor (mm ²)			
	380	400	415	440	380	400	415	440	380	400	415	440
Input	1600 <i>I_r</i> =0.9	1600 <i>I_r</i> =0.9	1600 <i>I_r</i> =0.9	1250 <i>I_r</i> =1.0	3x240/ 4x240	3x240/ 4x240	3x240/ 4x240	3x185/ 4x240	2x185/ 2x240	2x185/ 2x240	2x185/ 2x240	2x150/ 2x240
Bypass	1250 <i>I_r</i> =0.95	1250 <i>I_r</i> =0.9	1250 <i>I_r</i> =0.9	1000 <i>I_r</i> = 1.0	3x185/ 4x185	3x185/ 3x240	3x185/ 3x240	2x240/ 3x240	2x150/ 2x185	2x150/ 2x185	2x150/ 2x185	1x240/ 2x185
Output	1250 <i>I_r</i> =0.95	1250 <i>I_r</i> =0.9	1250 <i>I_r</i> =0.9	1000 <i>I_r</i> =1.0	3x185/ 4x185	3x185/ 3x240	3x185/ 3x240	2x240/ 3x240	2x150/ 2x185	2x150/ 2x185	2x150/ 2x185	1x240/ 2x185
Battery	2500	2500	2500	2500	4x240/ 5x240	4x240/ 5x240	4x240/ 5x240	4x240/ 5x240	2x240/ 3x240	2x240/ 3x240	2x240/ 3x240	2x240/ 3x240

Recommended Upstream Protection and Cable Sizes for 800 kW UPS

Voltage (V)	Maximum OCPD (A)				Conductors per Phase Copper/ Aluminium (mm ²)				PE Conductor (mm ²)			
	380	400	415	440	380	400	415	440	380	400	415	440
Input	1600 <i>I_r</i> =0.9	1600 <i>I_r</i> =0.9	1600 <i>I_r</i> =0.9	1600 <i>I_r</i> =0.9	3x240/ 4x240	3x240/ 4x240	3x240/ 4x240	3x240/ 4x240	2x185/ 2x240	2x185/ 2x240	2x185/ 2x240	2x185/ 2x240
Bypass	1250 <i>I_r</i> =1.0	1250 <i>I_r</i> =0.95	1250 <i>I_r</i> =0.9	1250 <i>I_r</i> =0.9	3x185/ 4x240	3x185/ 4x185	3x185/ 3x240	3x185/ 3x240	2x150/ 2x185	2x150/ 2x185	2x150/ 2x185	2x150/ 2x185
Output	1250 <i>I_r</i> =1.0	1250 <i>I_r</i> =0.95	1250 <i>I_r</i> =0.9	1250 <i>I_r</i> =0.9	3x185/ 4x240	3x185/ 4x185	3x185/ 3x240	3x185/ 3x240	2x150/ 2x185	2x150/ 2x185	2x150/ 2x185	2x150/ 2x185
Battery	2500	2500	2500	2500	4x240/ 5x240	4x240/ 5x240	4x240/ 5x240	4x240/ 5x240	2x240/ 3x240	2x240/ 3x240	2x240/ 3x240	2x240/ 3x240

Recommended Upstream Protection and Cable Sizes for 1000 kW UPS

Voltage (V)	Maximum OCPD (A)				Conductors per Phase Copper/ Aluminium (mm ²)				PE Conductor (mm ²)			
	380	400	415	440	380	400	415	440	380	400	415	440
Input	2000 I _r =0.9	2000 I _r =0.9	2000 I _r =0.9	2000 I _r =0.9	4x240/ 6x240	4x240/ 6x240	4x240/ 6x240	4x240/ 6x240	2x240/ 3x240	2x240/ 3x240	2x240/ 3x240	2x240/ 3x240
Bypass	1600 I _r =0.98	1600 I _r =0.95	1600 I _r =0.9	1600 I _r =0.9	4x185/ 5x240	4x185/ 5x240	3x240/ 4x240	3x240/ 4x240	2x185/ 3x240	2x185/ 3x240	2x185/ 2x240	2x185/ 2x240
Output	1600 I _r =0.98	1600 I _r =0.98	1600 I _r =0.9	1600 I _r =0.9	4x240/ 6x240	4x240/ 6x240	3x240/ 6x240	3x240/ 6x240	2x240/ 3x240	2x240/ 3x240	2x240/ 3x240	2x240/ 3x240
Battery	3300	3300	3300	3300	5x240/ 7x240	5x240/ 7x240	5x240/ 7x240	5x240/ 7x240	3x240/ 4x240	3x240/ 4x240	3x240/ 4x240	3x240/ 4x240

Recommended Upstream Protection and Cable Sizes for 1100 kW UPS

Voltage (V)	Maximum OCPD (A)				Conductors per Phase Copper/ Aluminium (mm ²)				PE Conductor (mm ²)			
	380	400	415	440	380	400	415	440	380	400	415	440
Input	2000 I _r =0.98	2000 I _r =0.98	2000 I _r =0.98	2000 I _r =0.95	4x300/ 5x300	4x300/ 5x300	4x300/ 5x300	4x300/ 5x300	2x300/ 3x300	2x300/ 3x300	2x300/ 3x300	2x300/ 3x300
Bypass	2000 I _r =0.9	2000 I _r =0.9	1600 I _r =0.98	1600 I _r =0.95	4x240/ 5x300	4x240/ 5x300	3x300/ 4x300	3x300/ 4x300	2x240/ 3x300	2x240/ 3x300	2x240 2x300	2x240/ 2x300
Output	2000 I _r =0.9	2000 I _r =0.9	1600 I _r =0.98	1600 I _r =0.95	4x240/ 5x300	4x240/ 5x300	3x300/ 4x300	3x300/ 4x300	2x240/ 3x300	2x240/ 3x300	2x240 2x300	2x240/ 2x300
Battery	3300	3300	3300	3300	5x300/ 7x300	5x300/ 7x300	5x300/ 7x300	5x300/ 7x300	3x300/ 4x300	3x300/ 4x300	3x300/ 4x300	3x300/ 4x300

Recommended Upstream Protection and Cable Sizes for 1250 kW UPS

	Maximum OCPD (A)				Conductors per Phase Copper/ Aluminium (mm ²)				PE Conductor (mm ²)			
	380 V	400 V	415 V	440 V	380 V	400 V	415 V	440 V	380 V	400 V	415 V	440 V
Input	2500 I _r =0.9	2500 I _r =0.9	2500 I _r =0.9	2500 I _r =0.9	5x240/ 6x300	5x240/ 6x300	5x240/ 6x300	5x240/ 6x300	3x240/ 3x300	3x240/ 3x300	3x240/ 3x300	3x240/ 3x300
Bypass	2000 I _r =0.98	2000 I _r =0.95	2000 I _r =0.9	2000 I _r =0.9	4x300/ 5x300	4x300/ 5x300	4x240/ 5x300	4x240/ 5x300	2x300/ 3x300	2x300/ 3x300	2x240/ 3x300	2x240/ 3x300
Output	2000 I _r =0.98	2000 I _r =0.95	2000 I _r =0.9	2000 I _r =0.9	4x300/ 5x300	4x300/ 5x300	4x240/ 5x300	4x240/ 5x300	2x300/ 3x300	2x300/ 3x300	2x240/ 3x300	2x240/ 3x300
Battery	4000	4000	4000	4000	6x300/ 7x300	6x300/ 7x300	6x300/ 7x300	6x300/ 7x300	3x300/ 4x300	3x300/ 4x300	3x300/ 4x300	3x300/ 4x300

Recommended Upstream Protection and Cable Sizes – UL

⚠ CAUTION
HAZARD OF FIRE
<ul style="list-style-type: none"> • Connect only to a circuit with the below specifications. • Connect only to a circuit provided with maximum a 1600 A branch circuit overcurrent protection in accordance with the National Electrical Code, ANSI/NFPA70, and the Canadian Electrical Code, Part I, C22.1.
Failure to follow these instructions can result in injury or equipment damage.

NOTE: Overcurrent protection is to be provided by others.

NOTE: All wiring must comply with all applicable national and/or electrical code (National Electrical Code, ANSI/NFPA 70).

Cable sizes in this manual are based on Table 310.15 of the National Electrical Code 2014 (NEC) with the following assertions:

- 90 °C conductors (THHN) for 75 °C termination
- Not more than 3 current carrying conductors in each conduit
- An ambient temperature of max. 30 °C
- Use of copper or aluminium conductors
- 100% rated breakers
- Nominal operating conditions

If the ambient room temperature is greater than 30 °C, use larger or additional parallel conductors in accordance with the correction factors of the NEC. The maximum allowable conductor size is 600 kcmil.

Equipment Grounding Conductors (EGC) are sized in accordance with NEC Article 250.122 and Table 250.122 Minimum size equipment conductor for grounding equipment.

NOTE: Always consider the EGC size according to the complete electrical installation.

NOTE: The use of aluminium conductors can limit the number of parallel Li-ion battery cabinets. Please contact Schneider Electric for more information.

Recommended Upstream Protection and Cable Sizes for 500 kW UPS

	Maximum OCPD (A)	Conductors per Phase Copper / Aluminium (kcmil)	Equipment Grounding Conductor Copper / Aluminium ⁵⁰
Input	800 (I _r = 1.0)	2x500 / 3x400	1/0 AWG / 3/0 AWG
Bypass	700 (I _r = 1.0)	2x350 / 2x500	1/0 AWG / 3/0 AWG
Output	700 (I _r = 1.0)	2x350 / 2x500	1/0 AWG / 3/0 AWG
Battery	1600 (I _r = 0.9)	4x500 / 5x500	4/0 AWG / 350 kcmil

Recommended Upstream Protection and Cable Sizes for 625 kW UPS

	Maximum OCPD (A)	Conductors per Phase Copper/ Aluminium (kcmil)	Equipment Grounding Conductor Copper/Aluminium ⁵⁰
Input	1000 (I _r = 1.0)	3x400 / 3x600	2/0 AWG / 4/0 AWG
Bypass	800 (I _r = 1.0)	2x600 / 3x400	1/0 AWG / 3/0 AWG
Output	800 (I _r = 1.0)	2x600 / 3x400	1/0 AWG / 3/0 AWG
Battery	2000 (I _r = 0.9)	5x500 / 6x500	250 kcmil / 400 kcmil

50. If the conductors are run in conduits, there must be one conductor in each conduit.

Recommended Upstream Protection and Cable Sizes for 750 kW UPS

	Maximum OCPD (A)	Conductors per Phase Copper/ Aluminium (kcmil)	Equipment Grounding Conductor Copper/Aluminium ⁵¹
Input	1200 ($I_r = 1.0$)	3x600 / 4x500	3/0 AWG / 250 kcmil
Bypass	1000 ($I_r = 1.0$)	3x400 / 3x600	2/0 AWG / 4/0 AWG
Output	1000 ($I_r = 1.0$)	3x400 / 3x600	2/0 AWG / 4/0 AWG
Battery	2500 ($I_r = 0.9$)	6x500 / 7x600	350 kcmil / 600 kcmil

Recommended Upstream Protection and Cable Sizes for 800 kW UPS

	Maximum OCPD (A)	Conductors per Phase Copper/ Aluminium (kcmil)	Equipment Grounding Conductor Copper/Aluminium ⁵¹
Input	1600 ($I_r = 0.8$)	4x400 / 4x600	4/0 AWG / 350 kcmil
Bypass	1000	3x400 / 3x600	2/0 AWG / 4/0 AWG
Output	1000	3x400 / 3x600	2/0 AWG / 4/0 AWG
Battery	2500 ($I_r = 0.9$)	6x500 / 7x600	350 kcmil / 600 kcmil

Recommended Upstream Protection and Cable Sizes for 1000 kW UPS

	Maximum OCPD (A)	Conductors per Phase Copper/ Aluminium (kcmil)	Equipment Grounding Conductor Copper/Aluminium ⁵¹
Input	1600 ($I_r = 1.0$)	4x600 / 5x600	4/0 AWG / 350 kcmil
Bypass	1600 ($I_r = 0.8$)	4x400 / 4x600	4/0 AWG / 350 kcmil
Output	1600 ($I_r = 0.8$)	4x400 / 4x600	4/0 AWG / 350 kcmil
Battery	3000 ($I_r = 1.0$)	8x500 / 9x600	400 kcmil / 600 kcmil

Recommended Upstream Protection and Cable Sizes for 1100 kW UPS

	Maximum OCPD (A)	Conductors per Phase Copper/ Aluminium (kcmil)	Equipment Grounding Conductor Copper/Aluminium ⁵¹
Input	2000 ($I_r = 0.9$)	5x500 / 6x500	250 kcmil / 400 kcmil
Bypass	1600 ($I_r = 0.9$)	4x500 / 5x500	4/0 AWG / 350 kcmil
Output	1600 ($I_r = 0.9$)	4x500 / 5x500	4/0 AWG / 350 kcmil
Battery	3000 ($I_r = 1.0$)	8x500 / 9x600	400 kcmil / 600 kcmil

Recommended Upstream Protection and Cable Sizes for 1250 kW UPS

	Maximum OCPD (A)	Conductors per Phase Copper/ Aluminium (kcmil)	Equipment Grounding Conductor Copper/Aluminium ⁵¹
Input	2000 ($I_r = 1.0$)	5x600 / 6x600	250 kcmil / 400 kcmil
Bypass	1600 ($I_r = 1.0$)	4x600 / 5x600	4/0 AWG / 350 kcmil
Output	1600 ($I_r = 1.0$)	4x600 / 5x600	4/0 AWG / 350 kcmil
Battery	4000 ($I_r = 0.9$)	9x600 / 11x600	500 kcmil / 750 kcmil

51. If the conductors are run in conduits, there must be one conductor in each conduit.

Recommended Bolt and Lug Sizes for Copper Cables

Cable Size	Terminal Bolt Diameter	Cable Lug Type	Crimping Tool	Die
1/0 AWG	M12 x 35 mm	LCCF1/0-12-X	CT930	CD-920-2/0 Black P45
2/0 AWG	M12 x 35 mm	LCCF2/0-12-X	CT930	CD-920-3/0 Orange P50
3/0 AWG	M12 x 35 mm	LCCF3/0-12-X	CT930	CD-920-4/0 Purple P54
250 kcmil	M12 x 35 mm	LCCF250-12-X	CT-940CH/CT-2940	CD-920-300 White P66
300 kcmil	M12 x 35 mm	LCCF300-12-6	CT-940CH/CT-2940	CD-920-350 Red P71
400 kcmil	M12 x 35 mm	LCCF400-12-6	CT-940CH/CT-2940	CD-920-500 Brown P87
500 kcmil	M12 x 35 mm	LCCF500-12-6	CT-940CH/CT-2940	CD-920-500A Pink P99
600 kcmil	M12 x 40 mm	LCCF600-12-6	CT-940CH/CT-2940	CD-920-750 Black P106

Recommended Bolt and Lug Sizes for Aluminium Cables

Cable Size	Terminal Bolt Diameter	Cable Lug Type	Crimping Tool	Die
2/0 AWG	M12 x 40 mm	LAB2/0-12-5	CT930	Olive P54
3/0 AWG	M12 x 40 mm	LAB3/0-12-5	CT930	Ruby P60
250 kcmil	M12 x 40 mm	LAB250-12-5	CT930	Red P71
300 kcmil	M12 x 40 mm	LAB300-12-2	CT930	Blue P76
400 kcmil	M12 x 40 mm	LAB400-12-2	CT930	Green P94
500 kcmil	M12 x 40 mm	LAB500-12-2	CT930	Pink P99
600 kcmil	M12 x 40 mm	LAB600-12-2	CT930	Black P106

Torque Specifications

Bolt size	Torque
M6	5 Nm (3.69 lb-ft)
M8	17.5 Nm (12.91 lb-ft)
M10	30 Nm (22 lb-ft)
M12	50 Nm (36.87 lb-ft)

Environment

	Operating	Storage
Temperature	0 °C to 40 °C (32 °F to 104 °F) 0 °C to 50 °C (32 °F to 122 °F) when derated to 75% power ⁵²	-15 °C to 40 °C (5 °F to 104 °F) for systems with batteries -25 °C to 55 °C (-13 °F to 131 °F) for systems without batteries
Relative humidity	0 – 95% non-condensing	0 – 95% non-condensing
Altitude derating according to ANSI C57.96-1999 ⁵³	1000 m (3300 ft): 1.000 1500 m (5000 ft): 0.975 2000 m (6600 ft): 0.950 2500 m (8300 ft): 0.925 3000 m (10000 ft): 0.900	0 – 15000 m (0 – 50000 ft)

52. For temperatures between 40 °C and 50 °C, the load power rating must be derated with 2.5% per °C of rated output power. Above 40 °C the minimum input voltage is 340 V, and from 380 V to 340 V, the charge power must be linearly derated from 12% to 1%.
53. Maximum operation altitude is 3000 m (10000 ft).

	Operating	Storage
Audible noise one meter (three feet) from surface	62 dB at 70% load 69.5 dB at 100% load for 400 V systems 68 dB at 100% load for 480 V systems	
Protection class	IP20	
Color	RAL 9003 white	

Heat Dissipation (BTU/hr) for UPSs with 1250 kW I/O Cabinet

Heat Dissipation for 500 kW UPS

Voltage (V)	Normal operation					ECO mode				
	380	400	415	440 V	480 V	380	400	415	440 V	480 V
25% load	17771	21504	21504	21504	22920	11385	16847	16387	14099	11835
50% load	34617	38327	38327	37397	36468	8616	11235	10360	12112	13870
75% load	56095	58889	58889	56095	53313	12924	15540	15540	15540	15540
100% load	78519	80387	78519	75723	72936	13758	17232	17232	17232	17232

Voltage (V)	ECOversion					Battery operation				
	380	400	415	440 V	480 V	380	400	415	440 V	480 V
25% load	4308	7376	6935	10264	13644	14555	15469	15011	15011	15011
50% load	13870	12990	16521	16078	15635	29110	29110	30938	30938	29110
75% load	12924	14231	14231	15540	16853	75903	47782	49160	49160	49160
100% load	17232	13758	13758	16362	18975	71083	74793	80387	80387	72936

Heat Dissipation for 625 kW UPS

Voltage (V)	Normal operation					ECO mode				
	380	400	415	440 V	480 V	380	400	415	440 V	480 V
25% load	27469	26880	26880	26880	28059	10880	13110	13670	13670	13670
50% load	47909	47909	47909	45006	42118	11859	14044	15139	15139	15139
75% load	73611	73611	73611	67509	61451	16155	19426	19426	19426	19426
100% load	114602	100484	98149	91170	84236	23718	25901	25901	23718	21540

Voltage (V)	ECOversion					Battery operation				
	380	400	415	440 V	480 V	380	400	415	440 V	480 V
25% load	15922	15922	10880	13390	15922	17056	17056	18764	18764	18764
50% load	17337	17337	17337	17337	17337	40967	39818	38672	38672	36387
75% load	21066	21066	21066	21066	21066	61451	61451	61451	61451	61451
100% load	25901	25901	25901	24809	23718	86543	84236	100484	100484	91170

Heat Dissipation for 750 kW UPS

	Normal operation					ECO mode				
Voltage (V)	380	400	415	440 V	480 V	380	400	415	440 V	480 V
25% load	28745	30847	30847	30847	30847	10402	13056	13723	13723	13723
50% load	56095	56095	54702	53313	51926	14231	16853	18167	18167	18167
75% load	94653	92542	86236	83097	79969	19386	23311	23311	23311	23311
100% load	146074	137523	129025	120581	112190	25848	28462	28462	28462	28462

	ECOConversion					Battery operation				
Voltage (V)	380	400	415	440 V	480 V	380	400	415	440 V	480 V
25% load	15061	15061	9084	12058	15061	21832	21832	22517	22517	23203
50% load	19485	19485	19485	19485	19485	45034	43664	45034	45034	45034
75% load	25279	25279	25279	25279	25279	77888	75812	75812	75812	75812
100% load	31081	31081	31081	29771	28462	114981	112190	112190	112190	112190

Heat Dissipation for 800 kW UPS

	Normal operation					ECO mode				
Voltage (V)	380	400	415	440 V	480 V	380	400	415	440 V	480 V
25% load	35160	35160	34407	34407	34407	15351	15351	8988	8988	8988
50% load	59835	58349	56867	55387	53911	19378	19378	15180	15180	15180
75% load	91985	89752	85300	84190	83081	22770	22770	22770	22770	22770
100% load	131616	128620	119669	112253	104876	30360	27572	27572	27572	27572

	ECOConversion					Battery operation				
Voltage (V)	380	400	415	440 V	480 V	380	400	415	440 V	480 V
25% load	17497	18216	17497	17857	18216	26956	21831	21105	21105	7590
50% load	20784	20784	20784	20784	20784	50968	43662	48036	48036	48036
75% load	24865	24865	24865	24865	24865	78657	65493	67676	67676	67676
100% load	30360	30360	27572	26180	24790	113733	101935	104876	104876	104876

Heat Dissipation for 1000 kW UPS

	Normal operation					ECO mode				
Voltage (V)	380	400	415	440 V	480 V	380	400	415	440 V	480 V
25% load	36468	39259	39259	39259	39259	12112	15635	16521	16521	16521
50% load	71083	71083	69234	69234	65547	15493	18975	20721	20721	20721
75% load	120581	117778	109405	109405	101083	20637	25848	25848	25848	25848
100% load	187156	175802	164520	164520	142167	27516	30987	30987	30987	30987

	ECOConversion					Battery operation				
Voltage (V)	380	400	415	440 V	480 V	380	400	415	440 V	480 V
25% load	18297	18297	10360	14311	18297	28198	28198	29110	29110	30023
50% load	22470	22470	22470	22470	22470	58219	56397	58219	58219	58219
75% load	28462	28462	28462	28462	28462	101083	98321	98321	98321	98321
100% load	34465	34465	34465	32725	30987	149587	145873	145873	145873	145873

Heat Dissipation for 1100 kW UPS

	Normal operation					ECO mode				
Voltage (V)	380	400	415	440 V	480 V	380	400	415	440 V	480 V
25% load	43185	43185	42160	43185	41136	18173	17199	17199	16713	16227
50% load	82273	78192	76158	76158	70080	22793	22793	22793	21832	20872
75% load	132639	123409	120345	120345	108153	28433	25564	25564	26998	28433
100% load	201700	185100	180972	180972	152315	37911	37911	37911	35997	34086

	ECOversion					Battery operation				
Voltage (V)	380	400	415	440 V	480 V	380	400	415	440 V	480 V
25% load	21107	21107	20127	18173	21107	35040	37064	36051	32021	36051
50% load	24717	22793	24717	22793	24717	66050	66050	70080	64041	68063
75% load	34189	34189	34189	28433	31308	163830	102095	105121	108153	105121
100% load	53291	41744	41744	34086	37911	156383	164545	176852	160460	152315

Heat Dissipation for 1250 kW UPS

	Normal operation					ECO mode				
Voltage (V)	380	400	415	440 V	480 V	380	400	415	440 V	480 V
25% load	49074	49074	47909	47909	46746	20651	19544	19544	18992	18440
50% load	93492	88854	86543	83084	79637	25901	25901	25901	24809	23718
75% load	154237	143726	140237	133281	126354	35578	32311	32311	30680	29050
100% load	233945	215042	210341	193965	177708	43081	43081	43081	40906	38734

	ECOversion					Battery operation				
Voltage (V)	380	400	415	440 V	480 V	380	400	415	440 V	480 V
25% load	22872	22872	21760	22316	22872	36387	38672	37528	37528	37528
50% load	28088	25901	28088	28088	28088	72774	72774	77345	77345	75057
75% load	35578	35578	35578	33943	32311	119455	119455	122901	122901	122901
100% load	56175	43081	43081	40906	38734	177708	186983	200969	200969	173085

Weights and Dimensions for UPSs with 1250 kW I/O Cabinet

Commercial Reference	Parts	Weight kg (lbs)	Height mm (in)	Width mm (in)	Depth mm (in)
<ul style="list-style-type: none"> • GVX500K500NHS • GVX500K500NGS • GVX500K750NHS • GVX500K750NGS • GVX500K1000NHS • GVX500K1000NGS • GVX500K1250NHS • GVX500K1250NGS 	Total – Power cabinets – I/O cabinet	2030 (4475) 2x540 (2x1190) 950 (2094)	1970 (77.6)	2400 (94.5) 2x600 (2x23.6) 1200 (47.2)	900 (35.4)
<ul style="list-style-type: none"> • GVX625K625NHS • GVX625K625NGS • GVX625K1000NHS • GVX625K1000NGS • GVX750K500NHS • GVX750K500NGS • GVX750K750NHS • GVX750K750NGS • GVX750K1000NHS • GVX750K1000NGS • GVX750K1250NHS • GVX750K1250NGS 	Total – Power cabinets – I/O cabinet	2570 (5666) 3x540 (3x1190) 950 (2094)	1970 (77.6)	3000 (118.1) 3x600 (3x23.6) 1200 (47.2)	900 (35.4)
<ul style="list-style-type: none"> • GVX800K800NHS • GVX800K800NGS • GVX1000K750NHS • GVX1000K750NGS • GVX1000K1000NHS • GVX1000K1000NGS • GVX1000K1250NHS • GVX1000K1250NGS 	Total – Power cabinets – I/O cabinet	3110 (6856) 4x540 (4x1190) 950 (2094)	1970 (77.6)	3600 (141.7) 4x600 (4x23.6) 1200 (47.2)	900 (35.4)
<ul style="list-style-type: none"> • GVX1100K1100NHS • GVX1100K1100NGS • GVX1250K1000NHS • GVX1250K1000NGS • GVX1250K1250NHS • GVX1250K1250NGS 	Total – Power cabinets – I/O cabinet	3650 (8047) 5x540 (5x1190) 950 (2094)	1970 (77.6)	4200 (165.4) 5x600 (5x23.6) 1200 (47.2)	900 (35.4)
<ul style="list-style-type: none"> • GVX1500K1100NHS • GVX1500K1100NGS • GVX1500K1250NHS • GVX1500K1250NGS 	Total – Power cabinets – I/O cabinet	4190 (9237) 6x540 (6x1190) 950 (2094)	1970 (77.6)	4800 (189.0) 6x600 (6x23.6) 1200 (47.2)	900 (35.4)

Clearance for UPSs with 1250 kW I/O Cabinet

NOTE: Clearance dimensions are published for airflow and service access only. Consult with the local safety codes and standards for additional requirements in your local area.

NOTE: The UPS system can be placed up against a wall and there is no requirement for rear or side access.

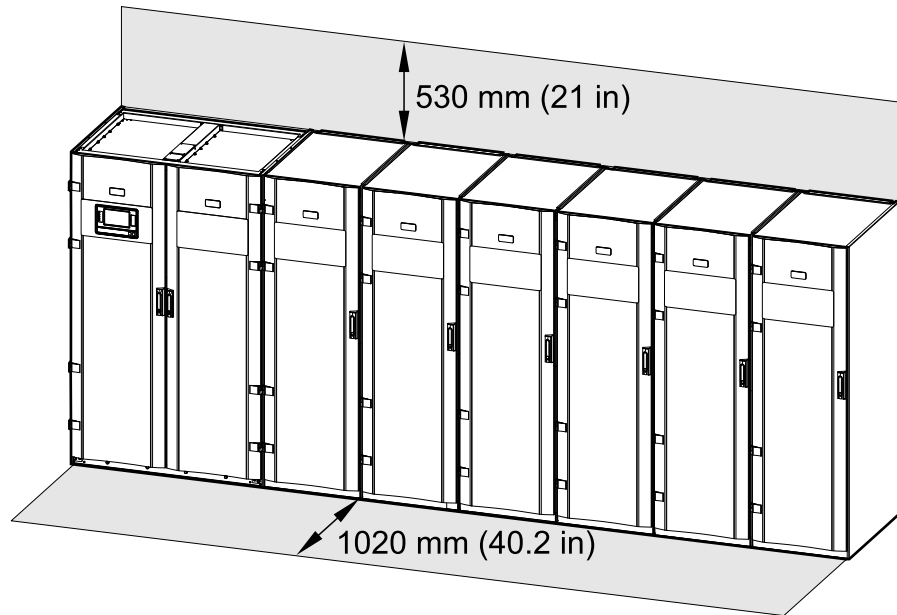

Guidance for Organizing Battery Cables

NOTE: For 3rd party batteries, use only high rate batteries for UPS applications.

NOTE: When the battery bank is placed remotely, the organizing of the cables is important to reduce voltage drop and inductance. The distance between the battery bank and the UPS must not exceed 200 m (656 ft). Contact Schneider Electric for installations with a longer distance.

NOTE: To minimize the risk of electromagnetic radiation, it is highly recommended to follow the below guidance and to use grounded metallic tray supports.

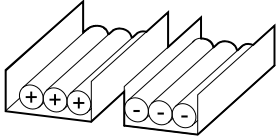
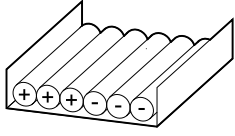
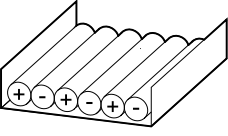
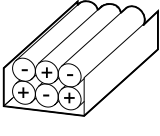
Cable Length				
<30 m	Not recommended	Acceptable	Recommended	Recommended
31–75 m	Not recommended	Not recommended	Acceptable	Recommended
76–150 m	Not recommended	Not recommended	Acceptable	Recommended
151–200 m	Not recommended	Not recommended	Not recommended	Recommended

Installation Procedure

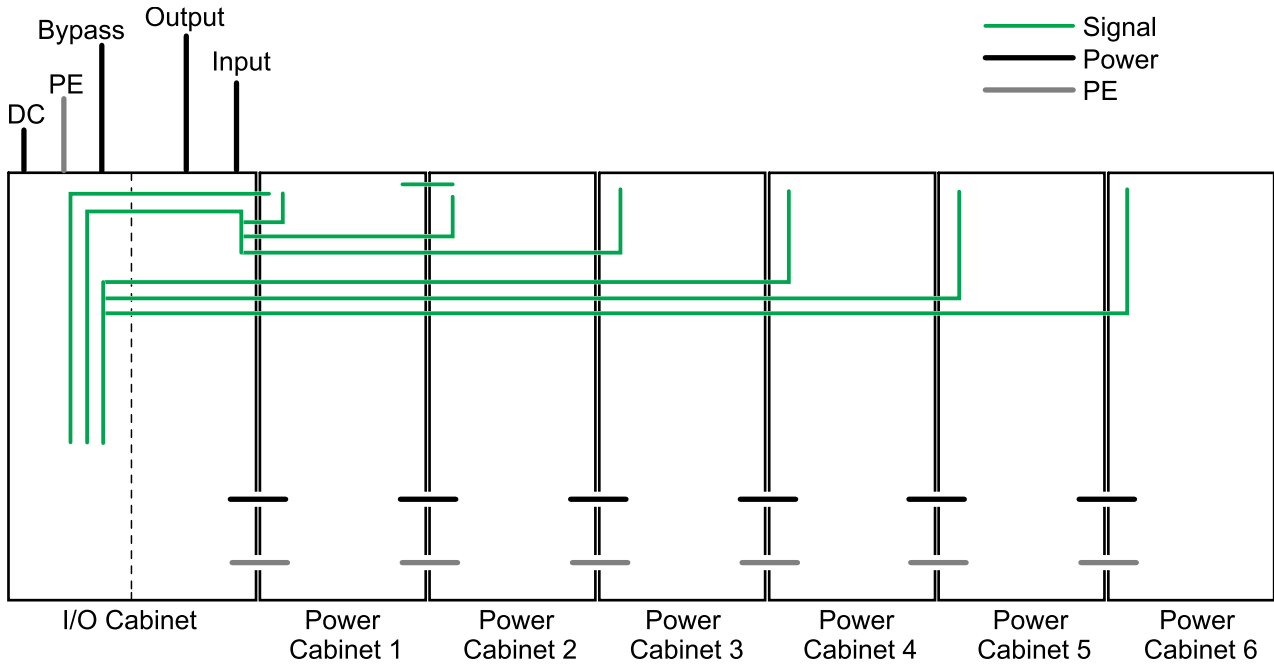

1. Remove the Cabinets from the Pallet, page 38.
2. Mount the Rear Anchoring Brackets, page 42.
3. Position the Cabinets, page 43.
4. Install Busbars between the Power Cabinets, page 51.
5. Install Busbars between the I/O Cabinet and the Left-Most Power Cabinet, page 52.
6. Prepare the I/O cabinet for power cables. Follow one of the procedures:
 - Prepare the I/O Cabinet for Power Cables in Top Cable Entry Systems, page 55.
 - Prepare the I/O Cabinet for Power Cables in Bottom Cable Entry Systems, page 56.
7. In dual mains systems only: Remove the Single Mains Busbars, page 58.
8. Connect the power cables. Follow one of the procedures:
 - Connect the Power Cables in a 380/400/415/440 V System, page 58.
 - Connect the Power Cables in a 480 V System, page 61.
9. Connect Cables to the External Supply for Li-Ion Battery Solution (Optional), page 63.
10. Mount the Front Anchoring Brackets, page 66.
11. Connect the Signal Cables between the I/O Cabinet and the Power Cabinets, page 67.
12. Route External Signal Cables to the Boards, page 72.
13. Final Mechanical Assembly, page 85.

Mechanical Installation

Remove the Cabinets from the Pallet

⚠ WARNING

HAZARD OF TILTING

Do not use a jack in the front and rear transport bracket at the same time.

Failure to follow these instructions can result in death, serious injury, or equipment damage.

⚠ WARNING

HAZARD OF SERIOUS INJURY

Do not put your hands or feet under the cabinet while removing the pallet parts.

Failure to follow these instructions can result in death, serious injury, or equipment damage.

NOTICE

RISK OF EQUIPMENT DAMAGE

Ensure that you have sufficient free space around the cabinets for the removal of the middle pallet part. The I/O cabinet requires 1.5 m (59 in) free space on the right or left side of the cabinet.

Failure to follow these instructions can result in equipment damage.

NOTICE

RISK OF EQUIPMENT DAMAGE

Ensure that the floor is level and can support the weight of the jack when it carries the cabinet.

Failure to follow these instructions can result in equipment damage.

NOTICE

RISK OF EQUIPMENT DAMAGE

Be careful not to damage the cabinets when using the jack.

Failure to follow these instructions can result in equipment damage.

NOTE: The illustrations show the removal of the power cabinet when the procedures are identical.

1. Use the installation kit 0M-816661 shipped with the I/O cabinet. Use the jack and the floor protection plate in the kit for all cabinets in this procedure.

- Place the floor protection plate under the pallet on the rear of the cabinet.

Rear View of the I/O Cabinet

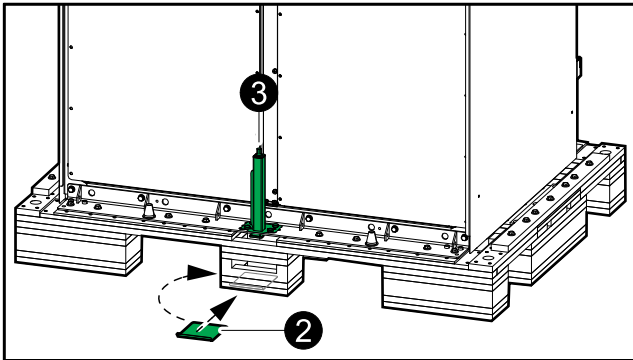

Rear View of the Power Cabinet

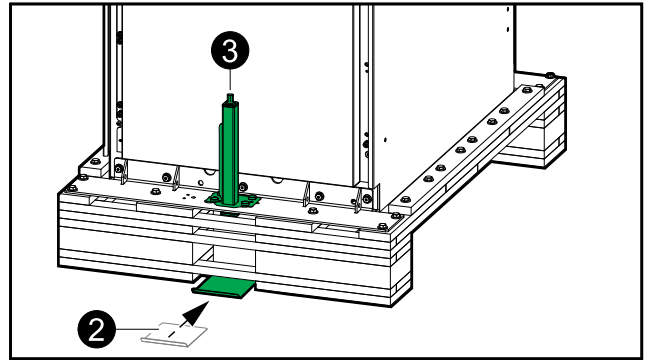

- Place the jack from the installation kit in the hole in the transport bracket on the rear of the cabinet.
- Remove the bolts from the rear transport bracket and from the middle pallet part. Remove the pallet parts marked with * and save for step 8.

Rear View of the Power Cabinet

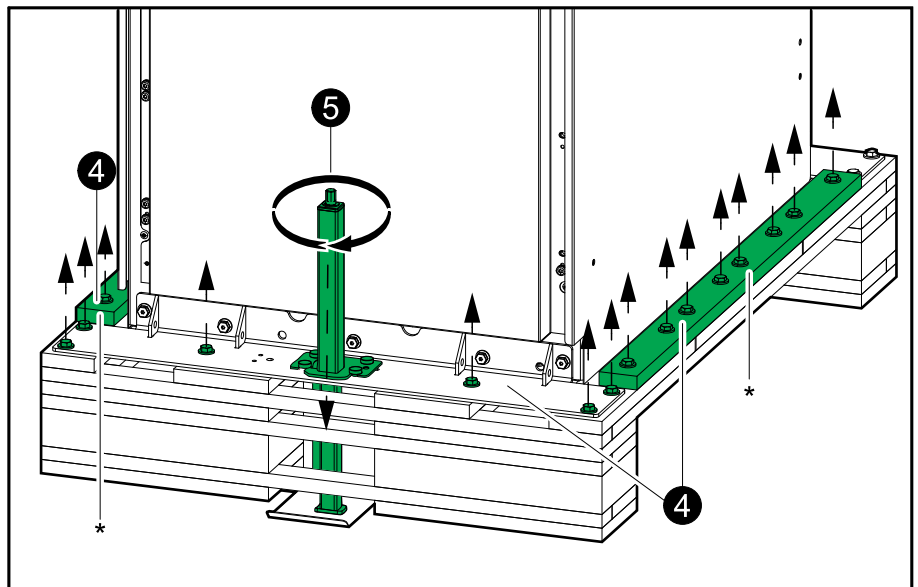

- Use a drilling machine with the provided hexagonal socket to activate the jack, slide it into position in the bracket, and to make contact with the floor protection plate.

NOTE: Reduce the drill torque to minimum to prevent kickback.

- Use the jack to lift the pallet to the top position.

7. Remove the rear and middle pallet parts and save the part marked with * for step 8.

Rear View of the I/O Cabinet

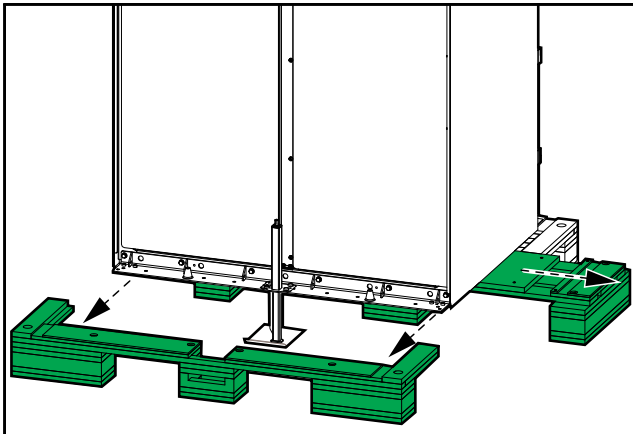

Rear View of the Power Cabinet

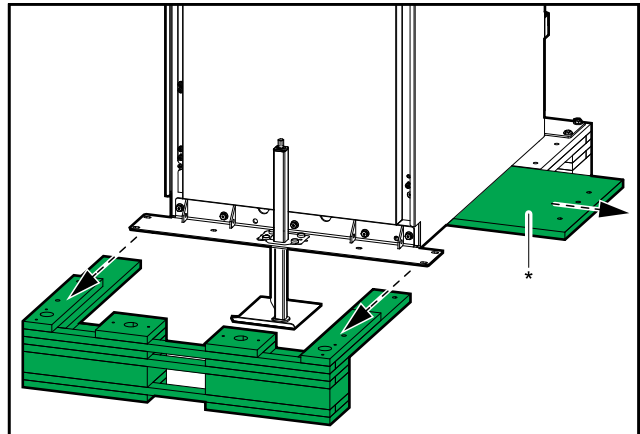

8. Place supports under the metal bracket:

- For the power cabinets, place the pallet parts from step 4 and 7 under the transportation bracket.
- For the I/O cabinet, place the pallet parts from step 4 under the transportation bracket.

Rear View of the I/O Cabinet

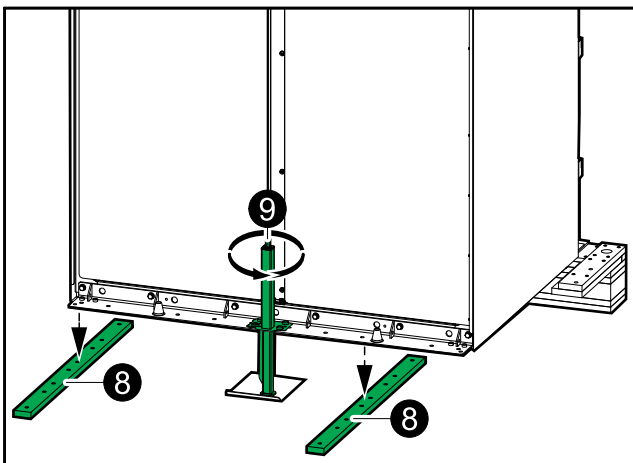

Rear View of the Power Cabinet

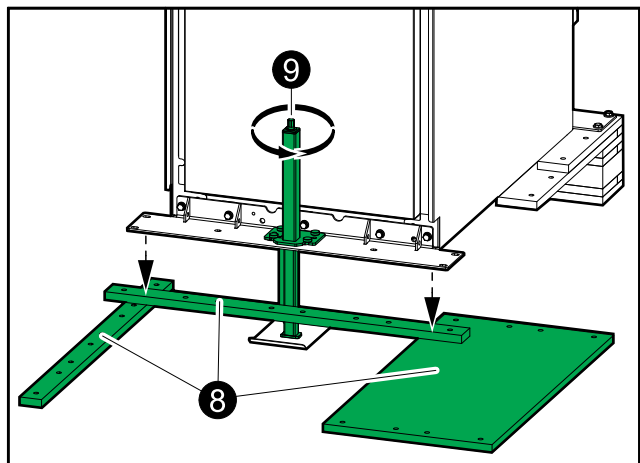

9. Use the drilling machine on the jack to lower the cabinet down onto the support.

10. Move the floor protection plate and the jack to the transport bracket on the front of the cabinet.

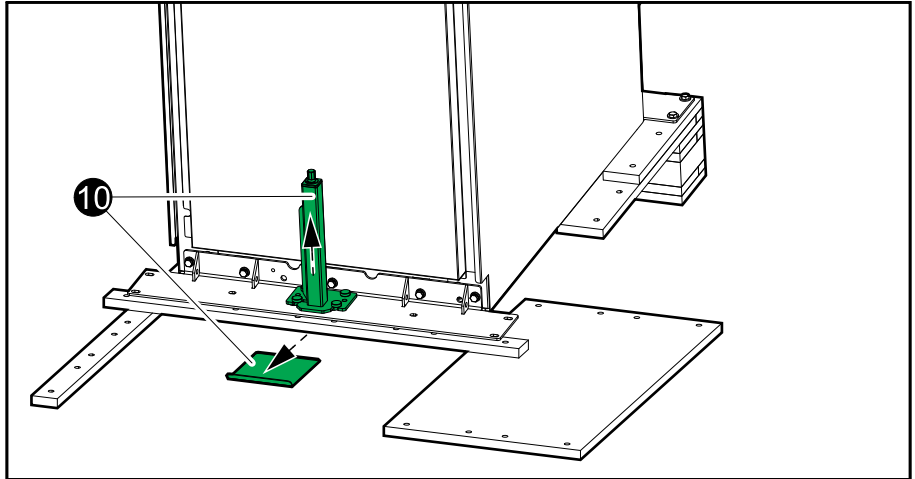

11. Remove the bolts from the front transport bracket.

Front View of the Power Cabinet

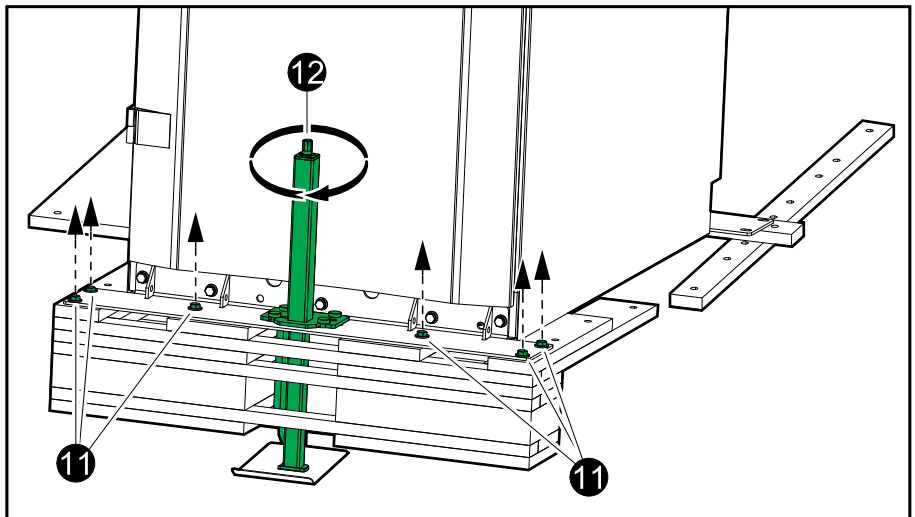

12. Use the jack to lift the pallet to the top position.
13. Remove the front pallet parts.

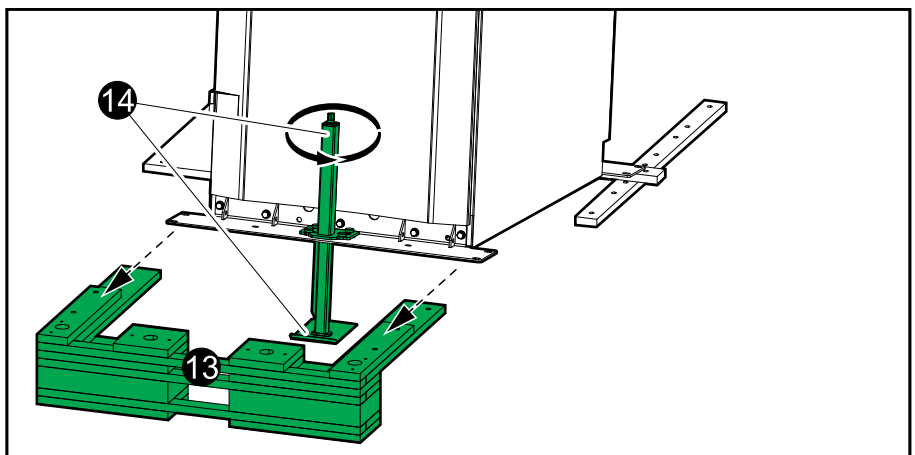

14. Use the jack to lower the cabinet onto the floor until the casters connect with the floor. Remove the jack and the floor protection plate.

15. Wheel the cabinet away and remove the remaining pallet parts.

⚠ WARNING

HAZARD OF TILTING

Be alert to uneven floors and doorsteps when moving the cabinet on its casters to avoid overbalancing and tipping the cabinet.

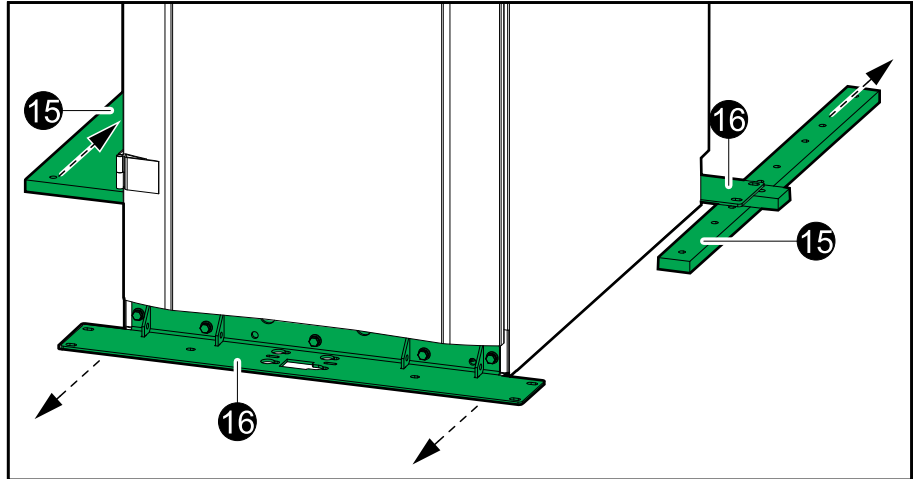

16. Remove the front and rear transportation brackets.

The cabinet can now be moved on the built-in casters to the installation area.

NOTE: Save the transportation brackets for later.

Mount the Rear Anchoring Brackets

⚠ DANGER

HAZARD OF ELECTRIC SHOCK, EXPLOSION, OR ARC FLASH

Leave the UPS system covered while making anchoring holes to prevent dust or other conductive particles from entering the system.

Failure to follow these instructions will result in death or serious injury.

⚠ WARNING

HAZARD OF TILTING

All rear and front anchoring brackets must be installed.

Failure to follow these instructions can result in death, serious injury, or equipment damage.

1. Use the rear anchoring bracket that was attached to the rear of the I/O cabinet. Fasten the plate from the installation kit 0H-9385 to the right side of the rear anchoring bracket of the I/O cabinet. Note the direction of the plate.

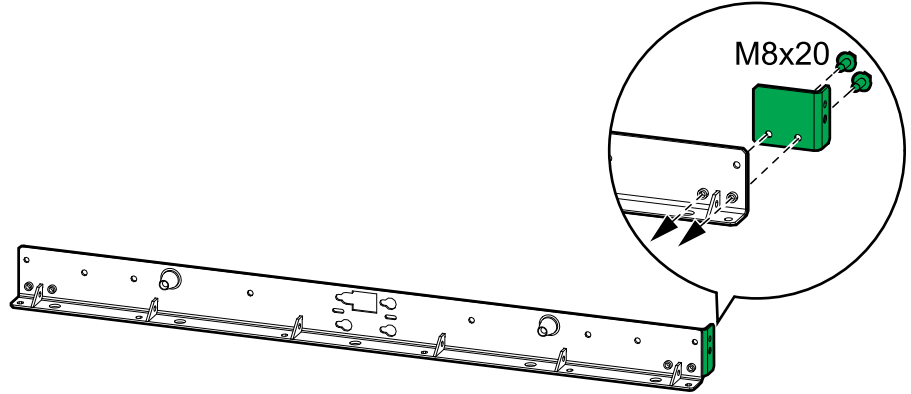

2. Place the rear anchoring brackets for the I/O cabinet and the power cabinets in the final installation area.

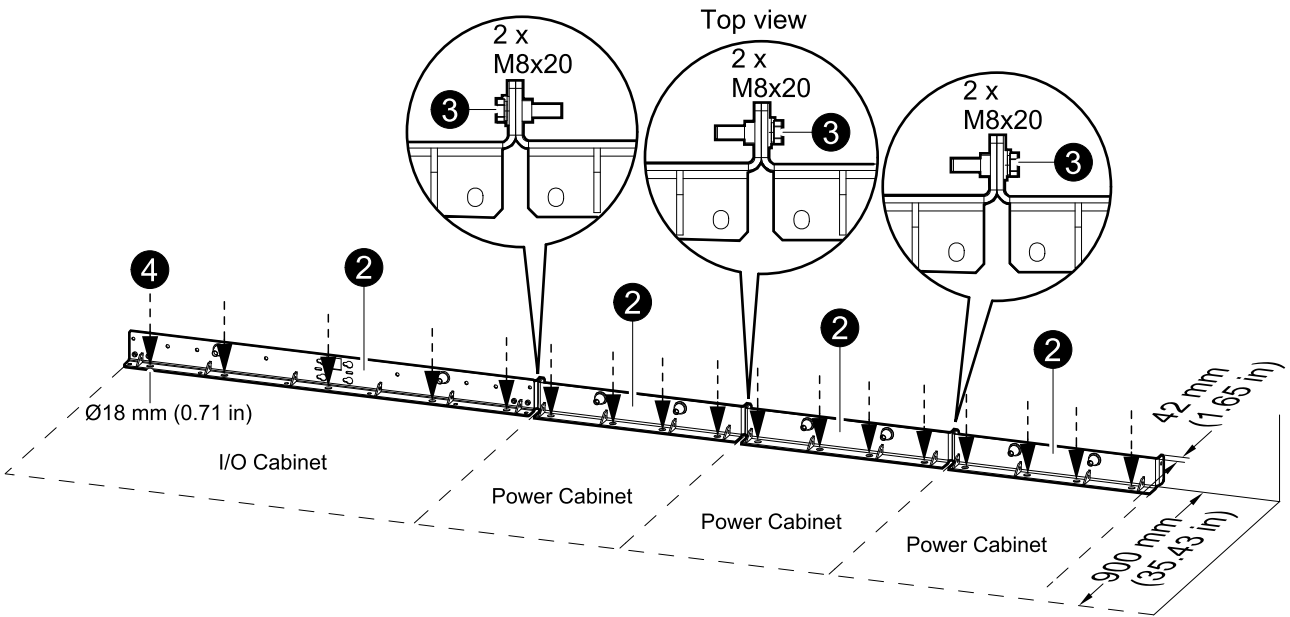

3. Interconnect the rear anchoring brackets using the provided screws and bolts.
4. Mark the hole locations.
5. Drill anchoring holes according to the national and local requirements.
6. Mount the rear anchoring brackets to the floor. Bolts are not supplied.
7. Use a bubble-leveler to ensure that the rear anchoring brackets are level. Use the provided leveling shims if necessary.

Position the Cabinets

⚠ DANGER

HAZARD OF ELECTRIC SHOCK, EXPLOSION, OR ARC FLASH

Do not step/walk on top of the cabinets.

Failure to follow these instructions will result in death or serious injury.

1. Install the cover from installation kit 0M-99582 on the right-most power cabinet.

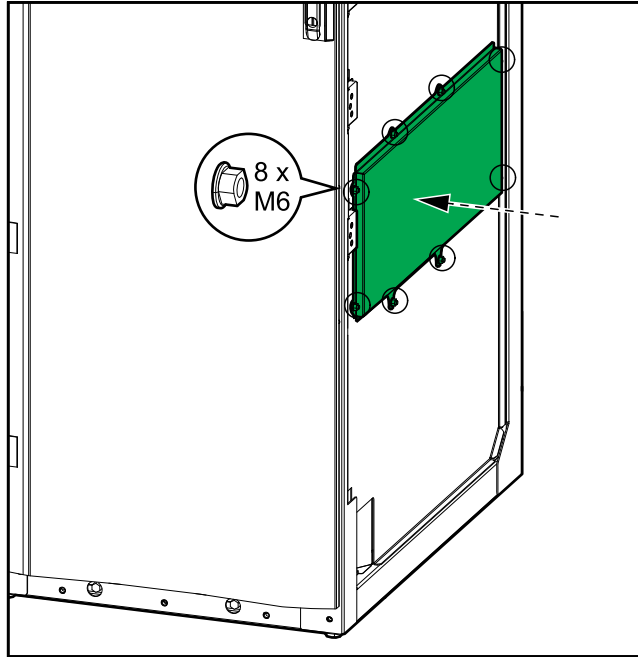

2. Move the side panel from the right side of the I/O cabinet and install it on the right-most power cabinet.

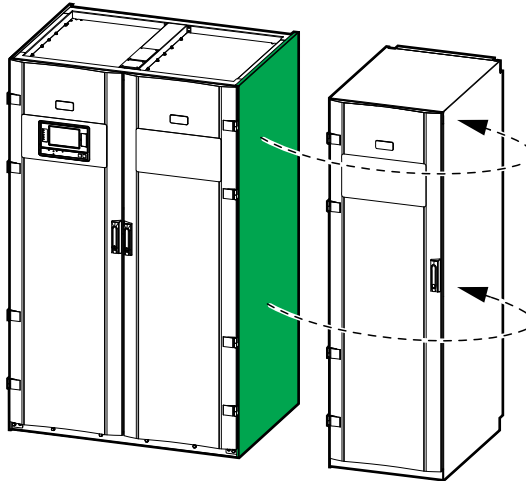

3. Open the two inner doors of the I/O cabinet.

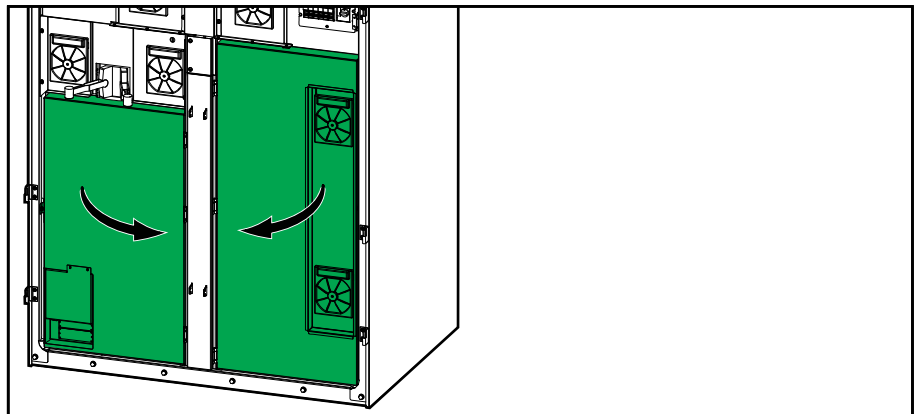

4. Remove the two rear bottom plates.

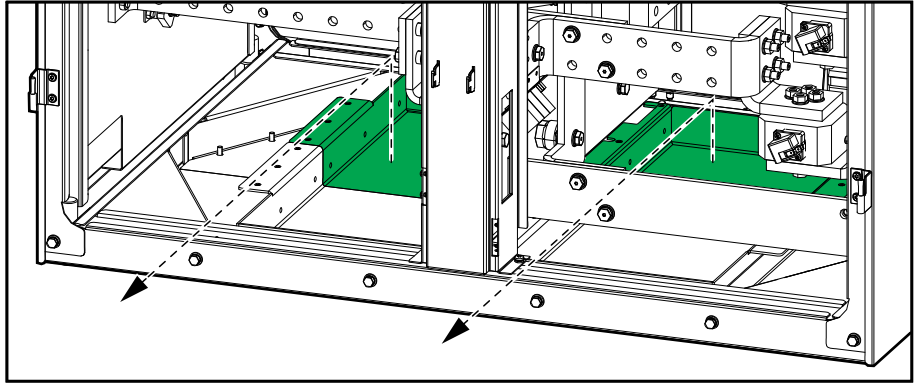

5. Push the I/O cabinet into position against the rear anchoring bracket - the I/O cabinet will connect to the conic outcroppings on the rear anchoring bracket.

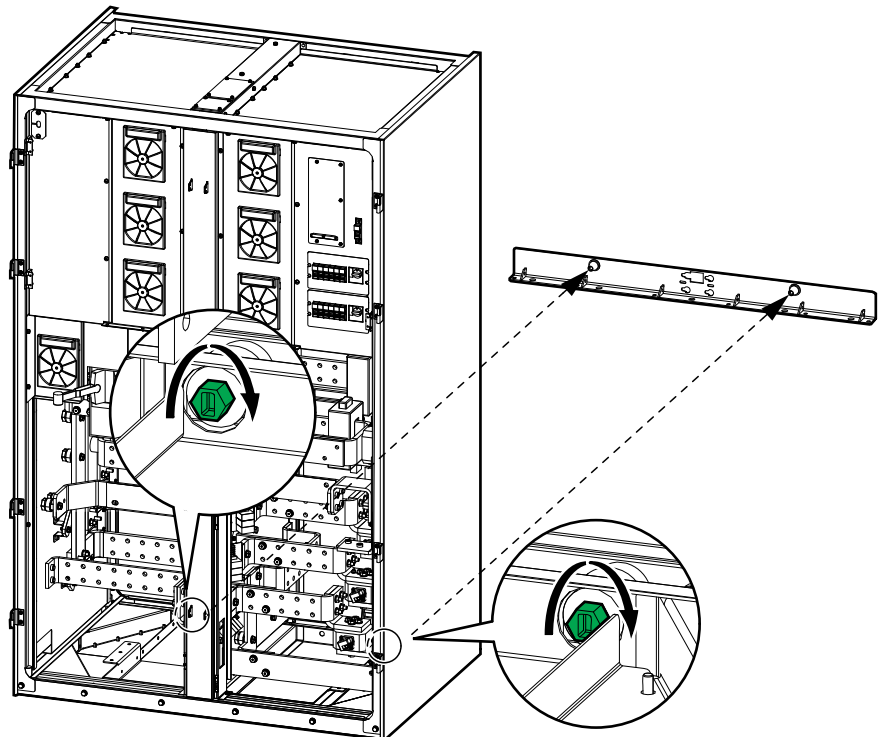

6. Fasten the cabinet to the rear anchoring bracket by tightening the bolts. Torque to 50 Nm (36.87 lb-ft).
7. Reinstall the two rear bottom plates.

8. Perform the following steps on all power cabinets:
 - a. Remove the 12 screws and open the fan door.

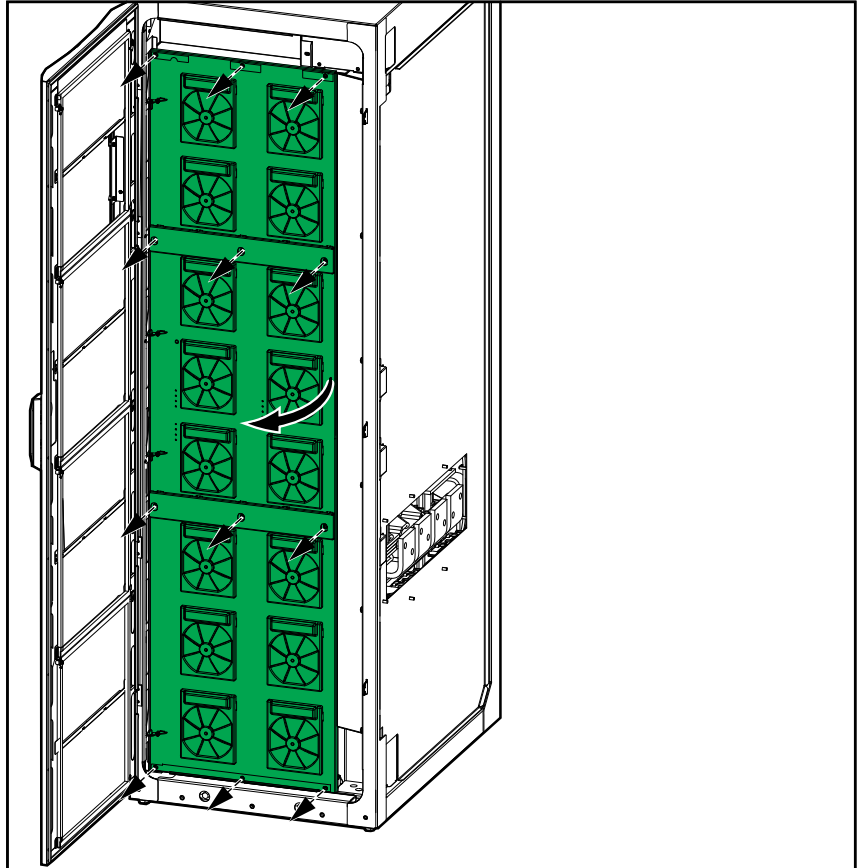

- b. Disconnect the cable between the fan door and the power cabinet.

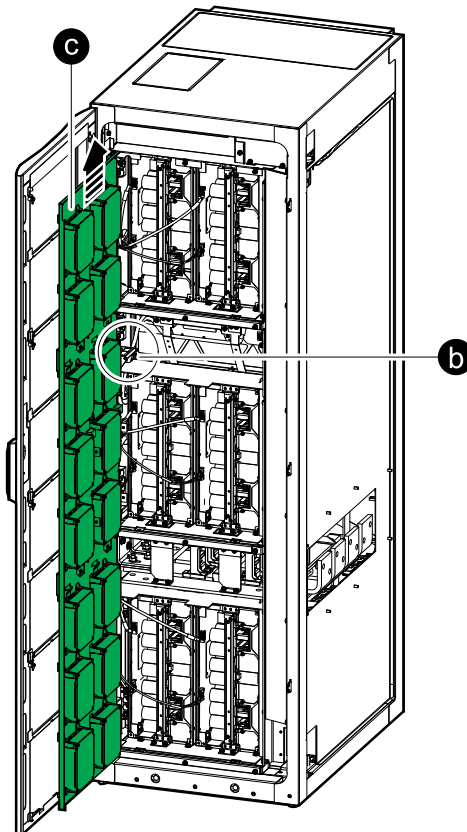

- c. Lift the fan door up and remove it.
 - d. Disconnect the two cables from each of the two middle power blocks.

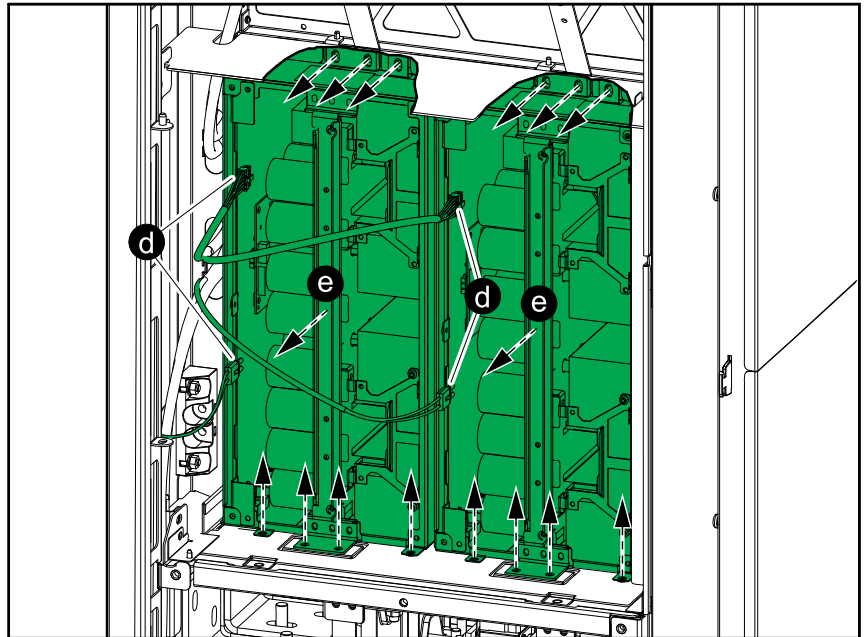

- e. Remove the middle power blocks. Be careful not to damage the cables.

NOTICE

RISK OF EQUIPMENT DAMAGE

Cover the power blocks when removed from the power cabinet to avoid dust in the power blocks.

Failure to follow these instructions can result in equipment damage.

- f. Remove the plate below the power blocks.

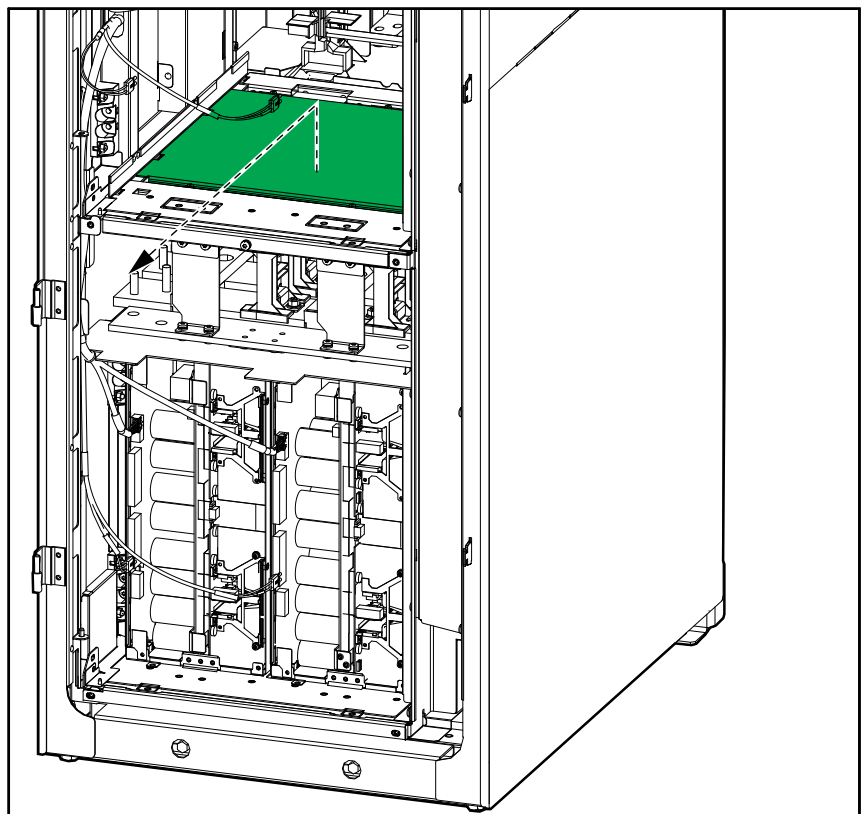

9. Push the power cabinets one by one into position against the rear anchoring brackets – the cabinets will connect to the conic outcroppings on the brackets.

⚠ CAUTION

RISK OF EQUIPMENT DAMAGE

When pushing the power cabinet into position, push on the frame to avoid damaging the signal cables.

Failure to follow these instructions can result in injury or equipment damage.

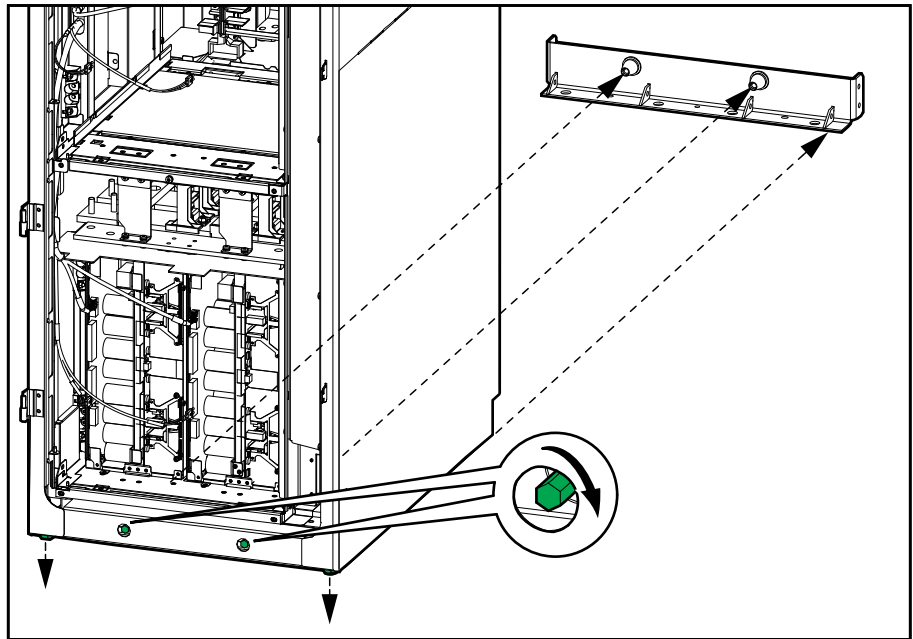

10. Fasten the power cabinets to the rear anchoring brackets by tightening the bolts on the front of the power cabinet. Torque to 50 Nm (36.87 lb-ft).
11. Lower the two front feet on all cabinets until they connect with the floor – use a bubble-leveler to ensure that the cabinets are level. Use the provided levelling shims if necessary.

12. Install the top baying bracket on the top of the cabinets and fasten with the provided screws.

I/O Cabinet and Two Power Cabinets

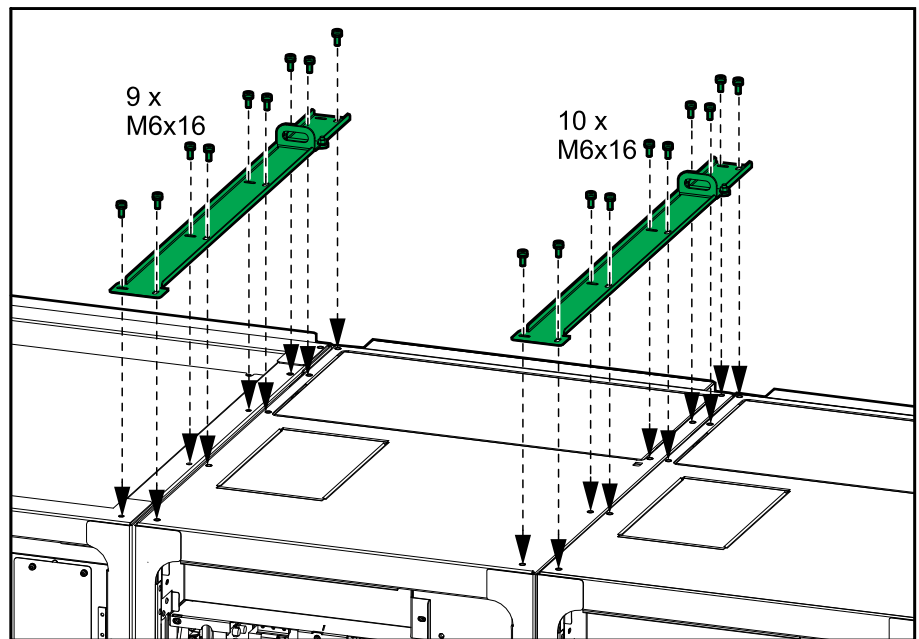

13. Mount the M6 screws from the installation kit from right to left in the five marked positions between the power cabinets and in the four marked positions between the power cabinet and the I/O cabinet to interconnect the cabinets.

From Power to Power Cabinet

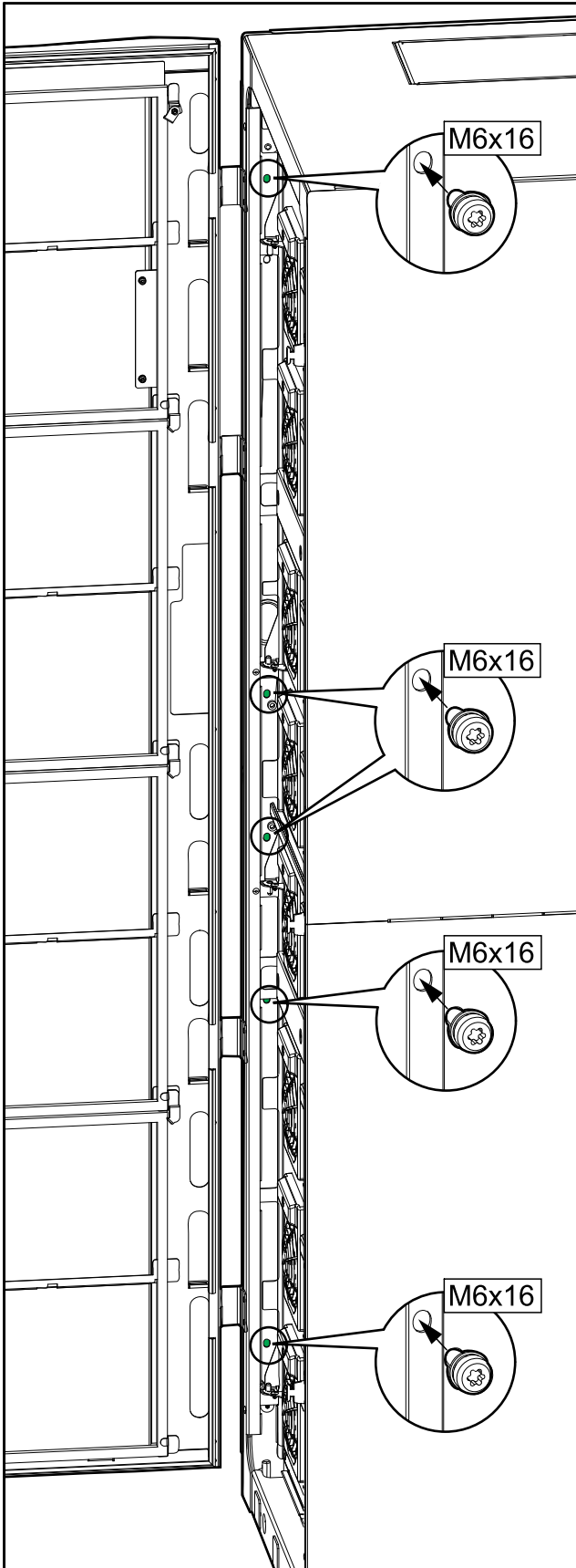

From Power to I/O Cabinet

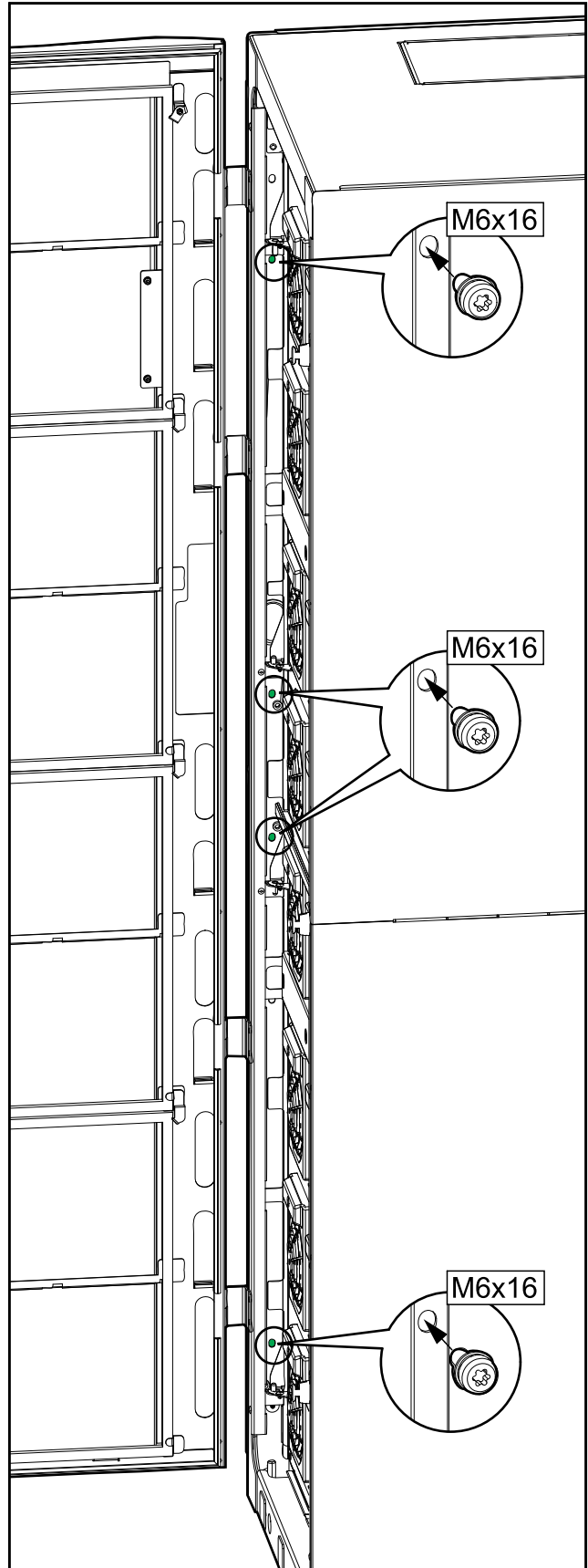

Install Busbars between the Power Cabinets

1. Install the grounding busbars 880-99027 from installation kit 0H-9162 between all power cabinets.

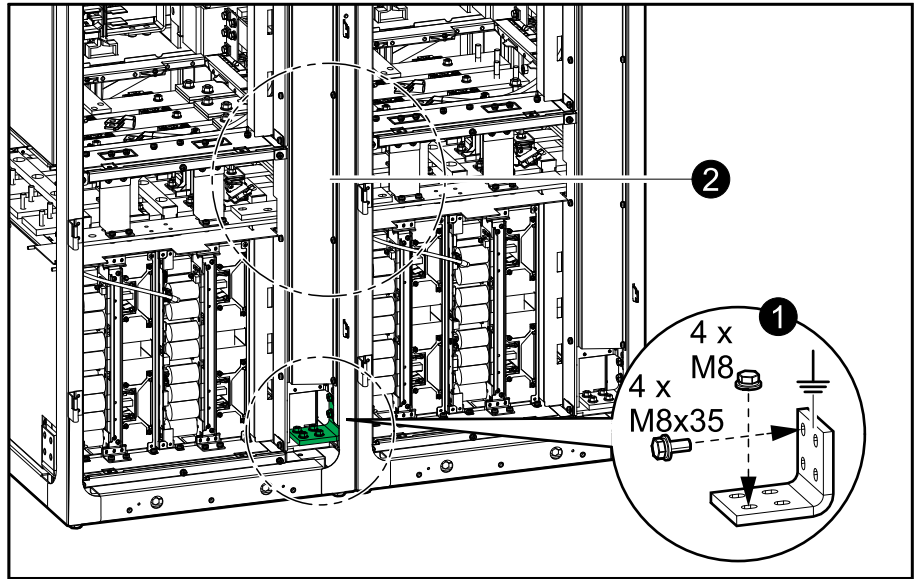

2. Install the interconnection busbars from installation kit 0H-9162 between all power cabinets.

- a. Install the three input interconnection busbars 0M-97885.

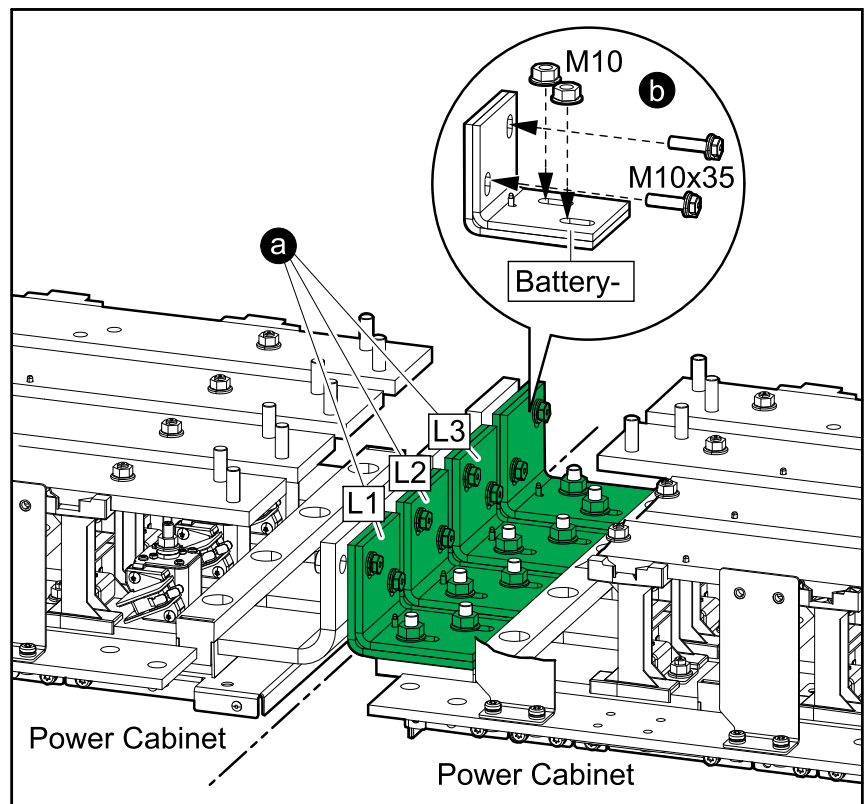

- b. Install the battery – interconnection busbar 0M-819336.

c. Install the battery + interconnection busbar 0M-140035.

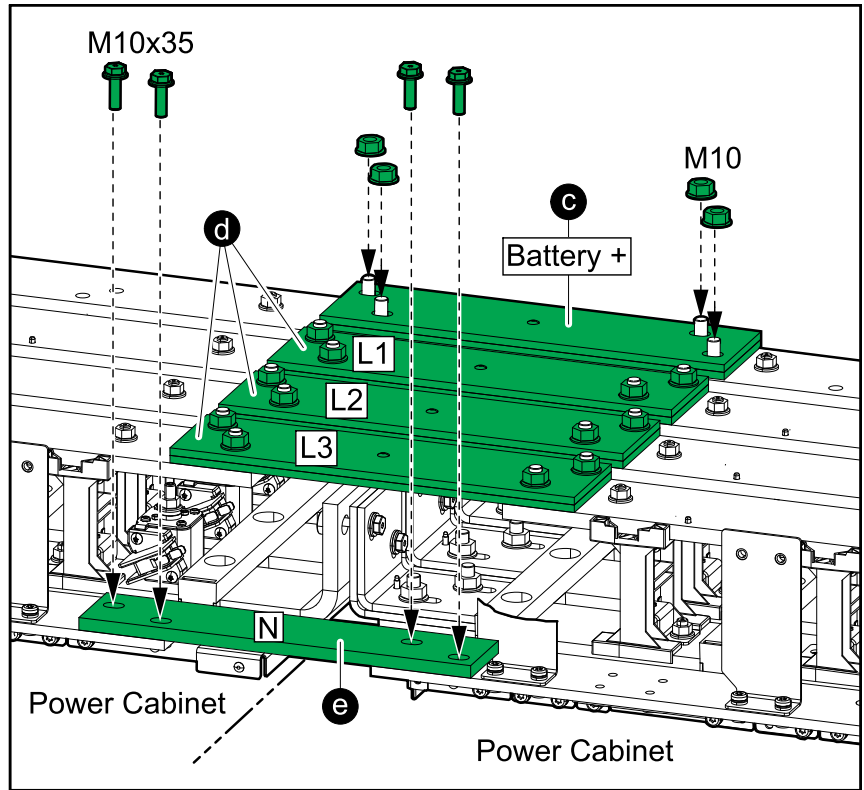

d. Install the output interconnection busbars 0M-97886.

e. Install the neutral interconnection busbar 880-9720.

Install Busbars between the I/O Cabinet and the Left-Most Power Cabinet

1. Install the grounding busbar 880-63286 from installation kit 0H-9385 between the I/O cabinet and the left-most power cabinet.

Front View of the I/O Cabinet and the Power Cabinet

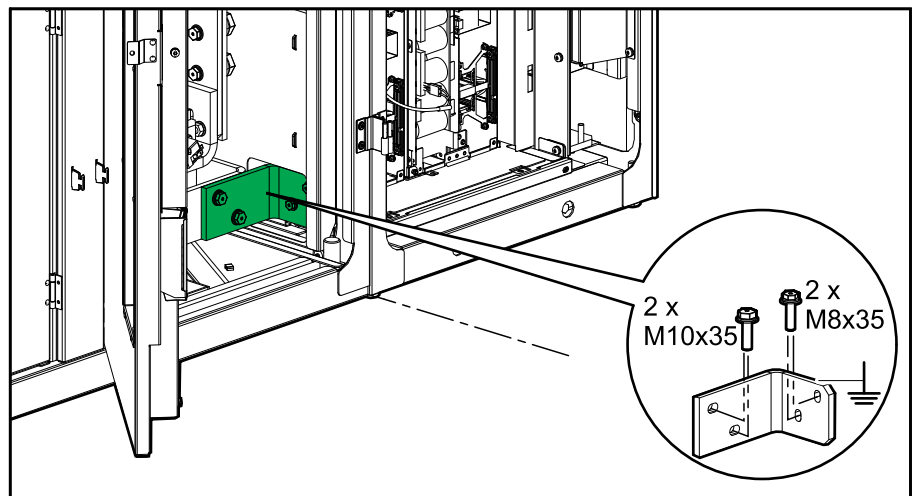

2. Install the interconnection busbars from the installation kit 0H-9162 (supplied with the power cabinet) between the I/O cabinet and the left-most power cabinet.

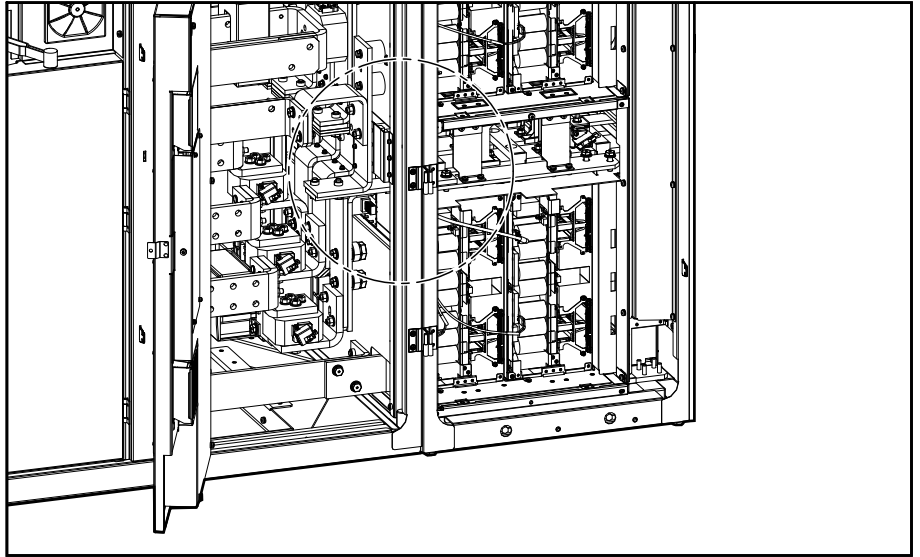

- a. Install the battery- interconnection busbar 0M-819336.

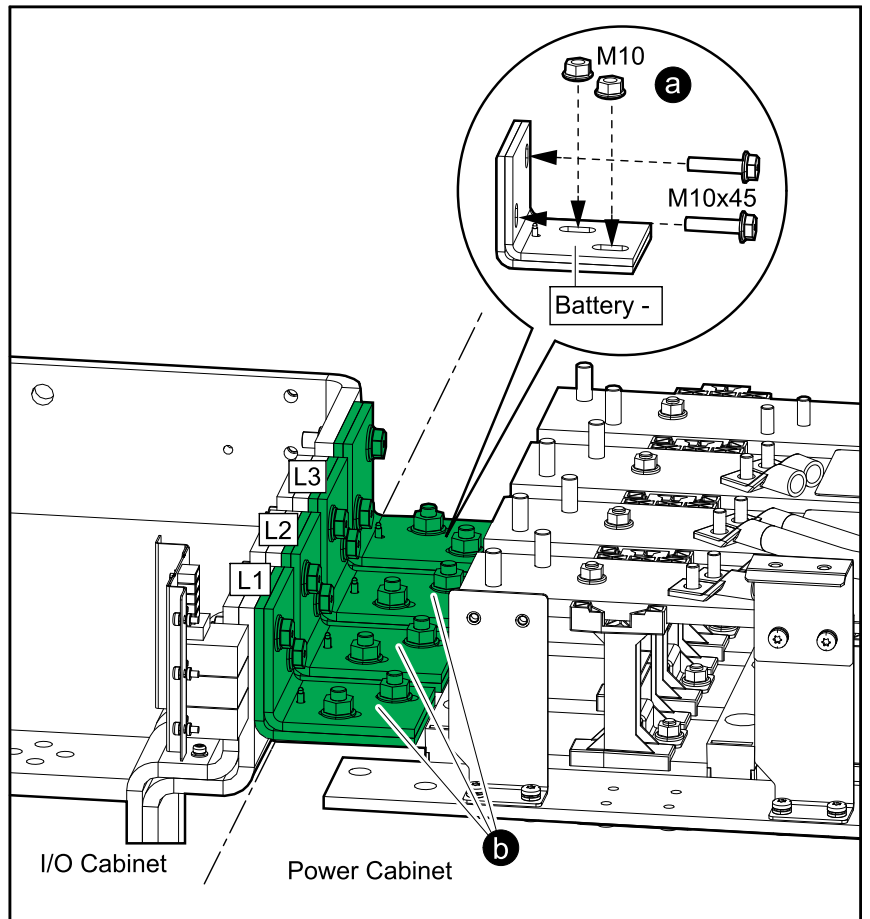

- b. Install the three input interconnection busbars 0M-97885.
- c. Install the battery+ interconnection busbar 0M-140035.

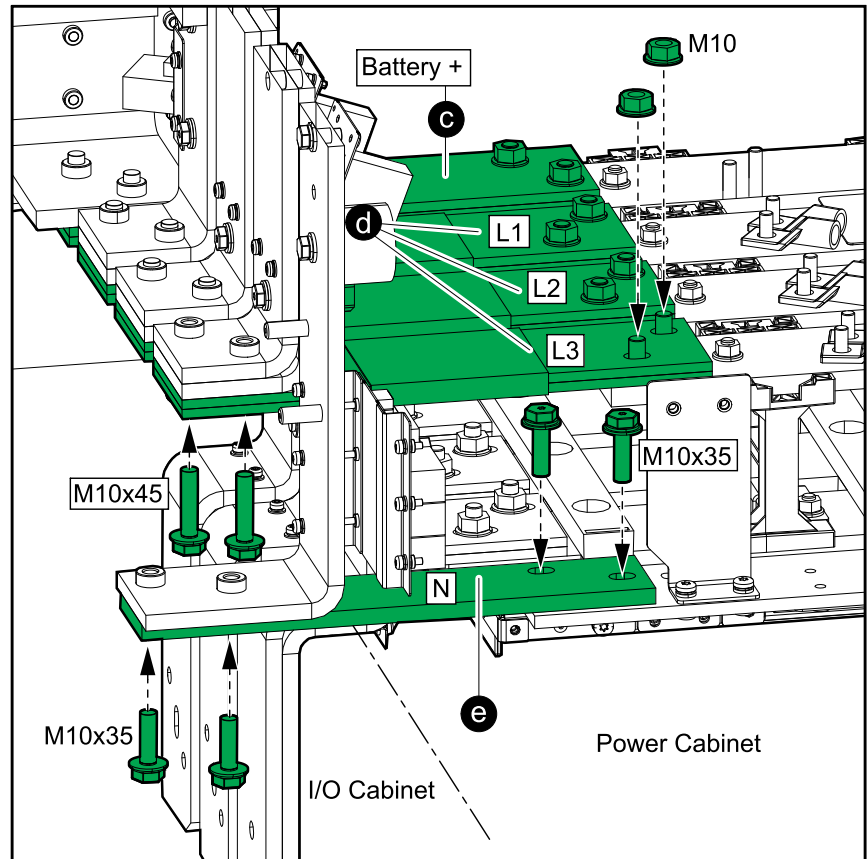

- d. Install the three output interconnection busbars 0M-97886.
- e. Install the neutral interconnection busbar 880-9720.

Connect the Power Cables

Prepare the I/O Cabinet for Power Cables in Top Cable Entry Systems

⚠ DANGER

HAZARD OF ELECTRIC SHOCK, EXPLOSION, OR ARC FLASH

Do not drill/punch holes for cables or conduits with the gland plates installed and do not drill/punch holes in close proximity to the UPS.

Failure to follow these instructions will result in death or serious injury.

1. Loosen the bolts and remove the gland plates from the top of the I/O cabinet.

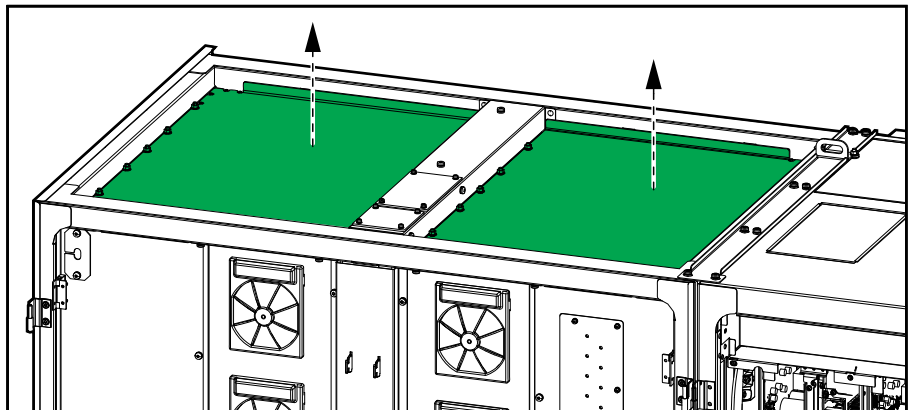

2. Drill or cut holes for cables/conduits in the top gland plate.

⚠ DANGER

HAZARD OF ELECTRIC SHOCK, EXPLOSION, OR ARC FLASH

Ensure that there are no sharp edges that can damage the cables.

Failure to follow these instructions will result in death or serious injury.

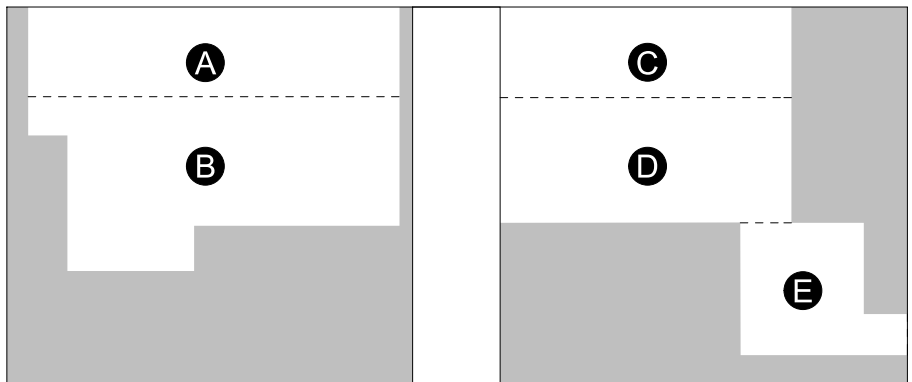

- A. For bypass cables
- B. For DC cables
- C. For output cables
- D. For input cables
- E. For cables to the external supply for Li-Ion

3. Install conduits and reinstall the top gland plate.

Prepare the I/O Cabinet for Power Cables in Bottom Cable Entry Systems

⚠ DANGER

HAZARD OF ELECTRIC SHOCK, EXPLOSION, OR ARC FLASH

Do not drill/punch holes for cables or conduits with the gland plates installed and do not drill/punch holes in close proximity to the UPS.

Failure to follow these instructions will result in death or serious injury.

NOTE: Cables to the external supply for Li-Ion battery solutions must be routed through the top. Follow the procedure Prepare the I/O Cabinet for Power Cables in Top Cable Entry Systems, page 55 to prepare for cables to the external supply.

1. Loosen the bolts and remove the gland plates in the bottom of the I/O cabinet.

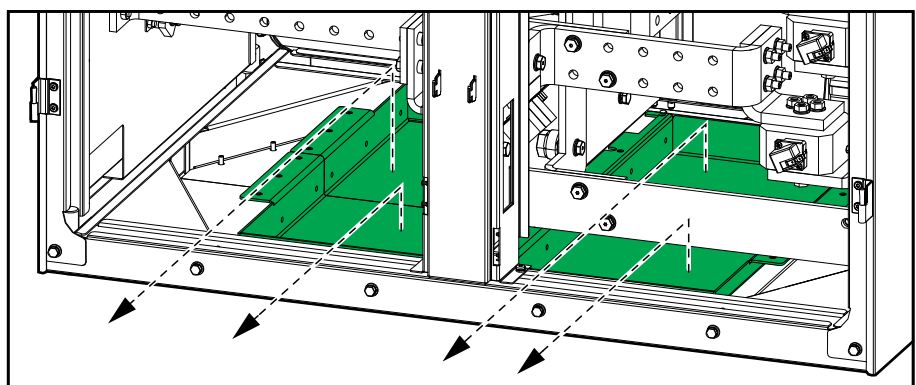

2. Drill or cut holes for cables/conduits in the bottom gland plate.

⚠ DANGER

HAZARD OF ELECTRIC SHOCK, EXPLOSION, OR ARC FLASH

Ensure that there are no sharp edges that can damage the cables.

Failure to follow these instructions will result in death or serious injury.

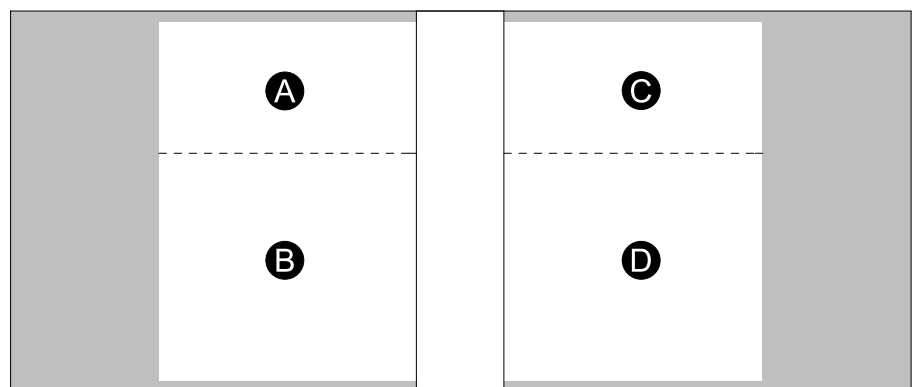

- A. For bypass cables
- B. For DC cables
- C. For output cables
- D. For input cables

3. Install conduits and install the bottom gland plates in the indicated order below the frame.

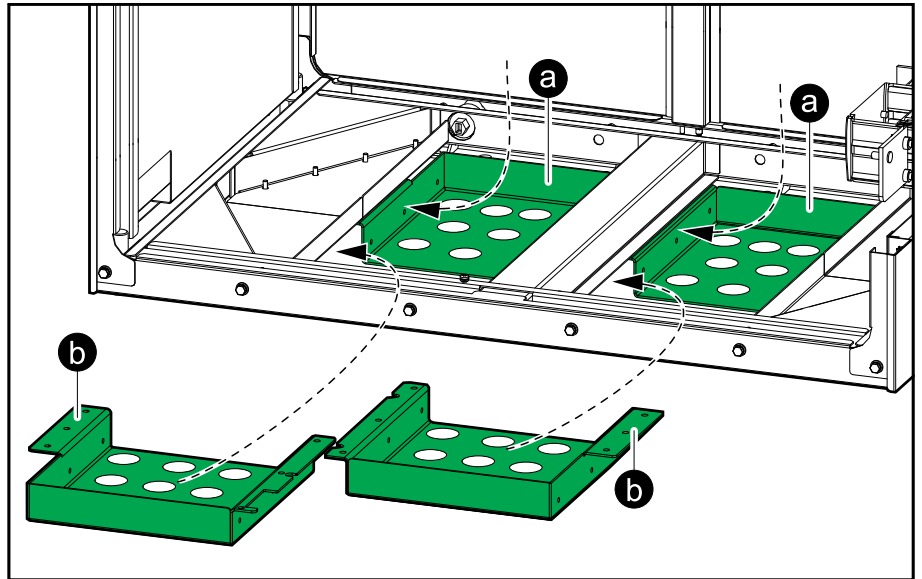

Remove the Single Mains Busbars

NOTE: This procedure is only applicable to dual mains systems.

1. Remove the three single mains busbars.

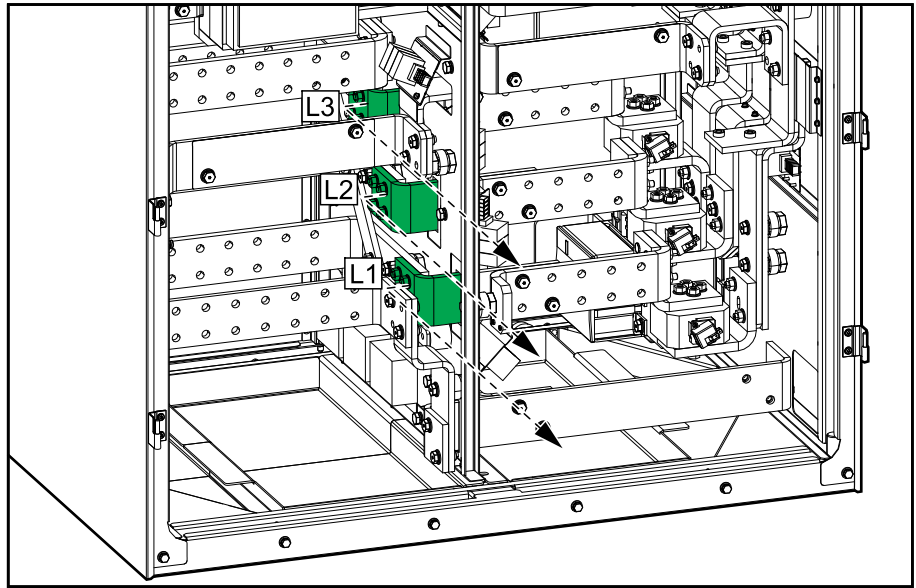

Connect the Power Cables in a 380/400/415/440 V System

1. Only applicable to installations with neutral connection: Remove the lexan plate from the N busbars.

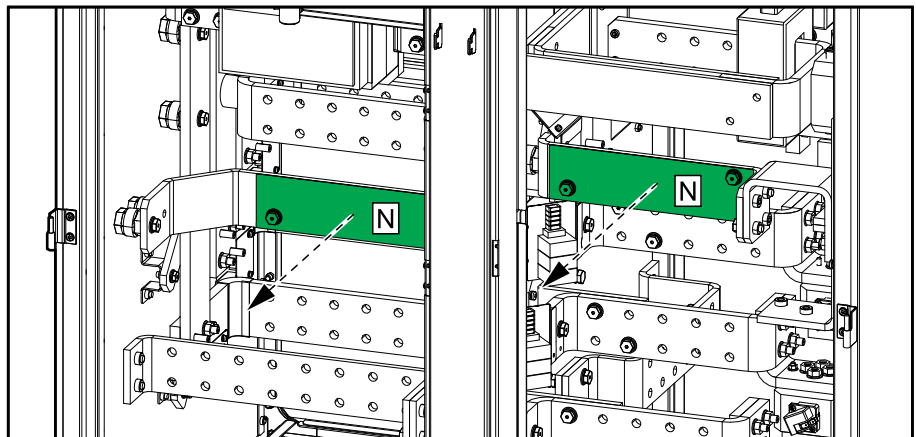

2. Only applicable to TNC systems:

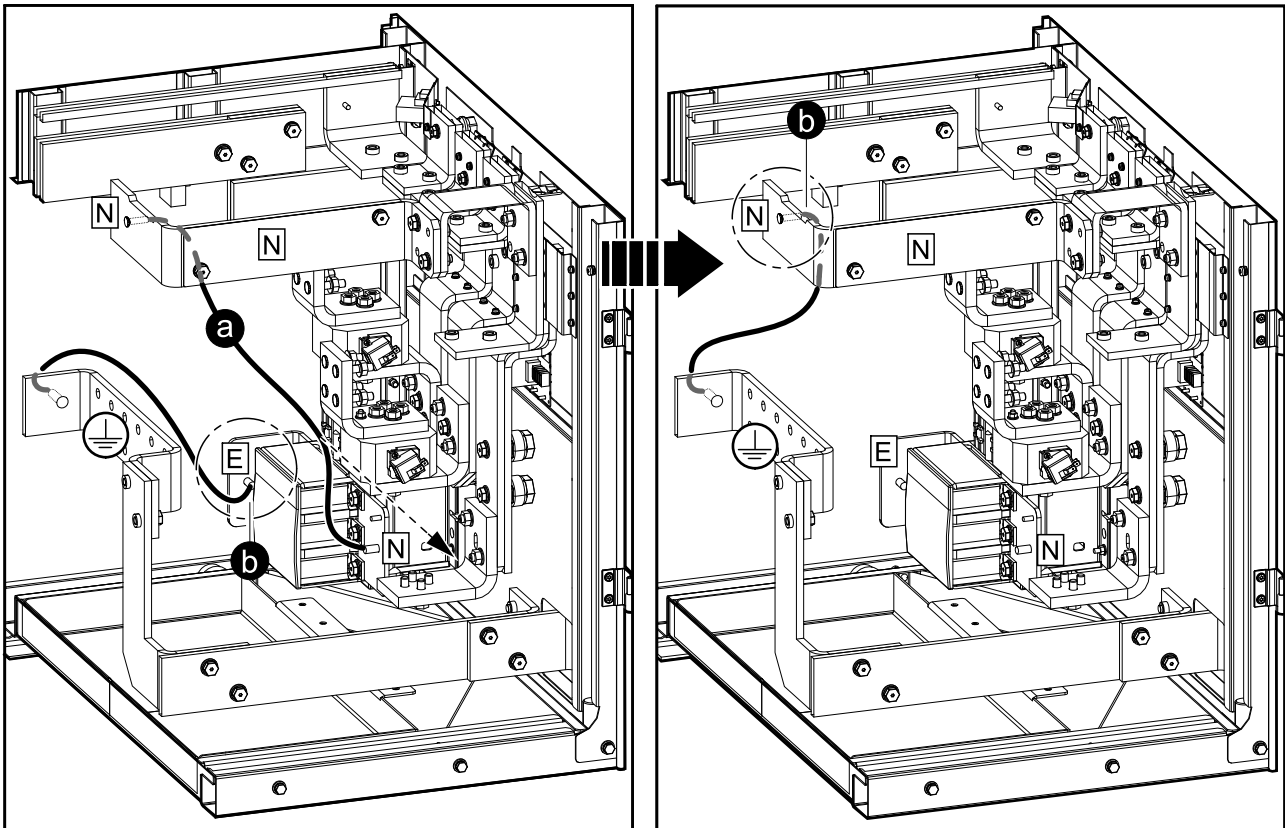

- a. Remove the jumper cable between the N terminal on the bonding contactor and the N busbar.
- b. Disconnect the jumper cable from the E terminal on the bonding contactor and connect to the N busbar.

3. Only applicable to 4-wire IT systems:

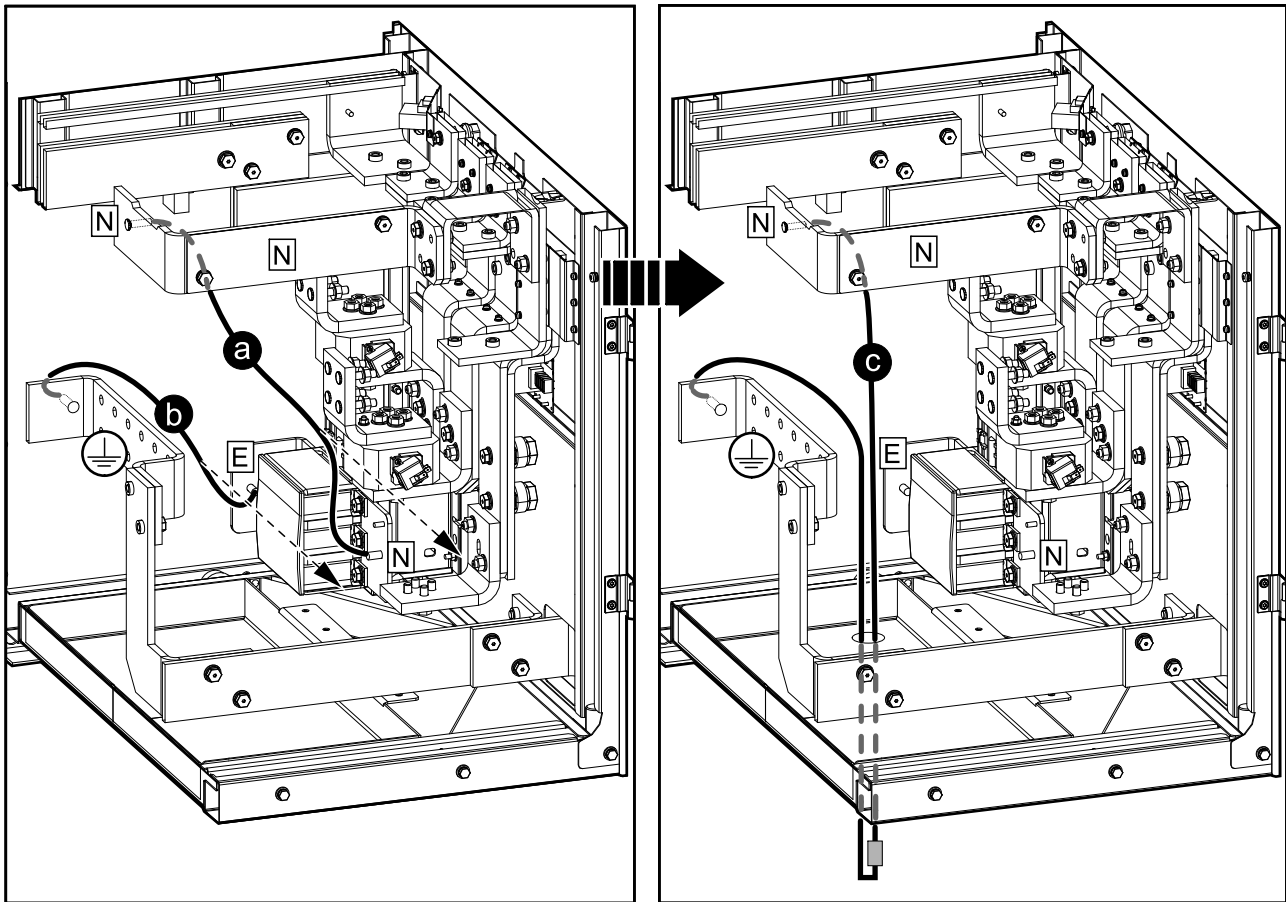

- a. Remove the jumper cable between the N terminal on the bonding contactor and the N busbar.
- b. Remove the jumper cable between the E terminal and the PE busbar.
- c. Connect an external impedance between the PE busbar and the N busbar.

4. Connect the equipment earthing conductor/PE to the PE busbar.

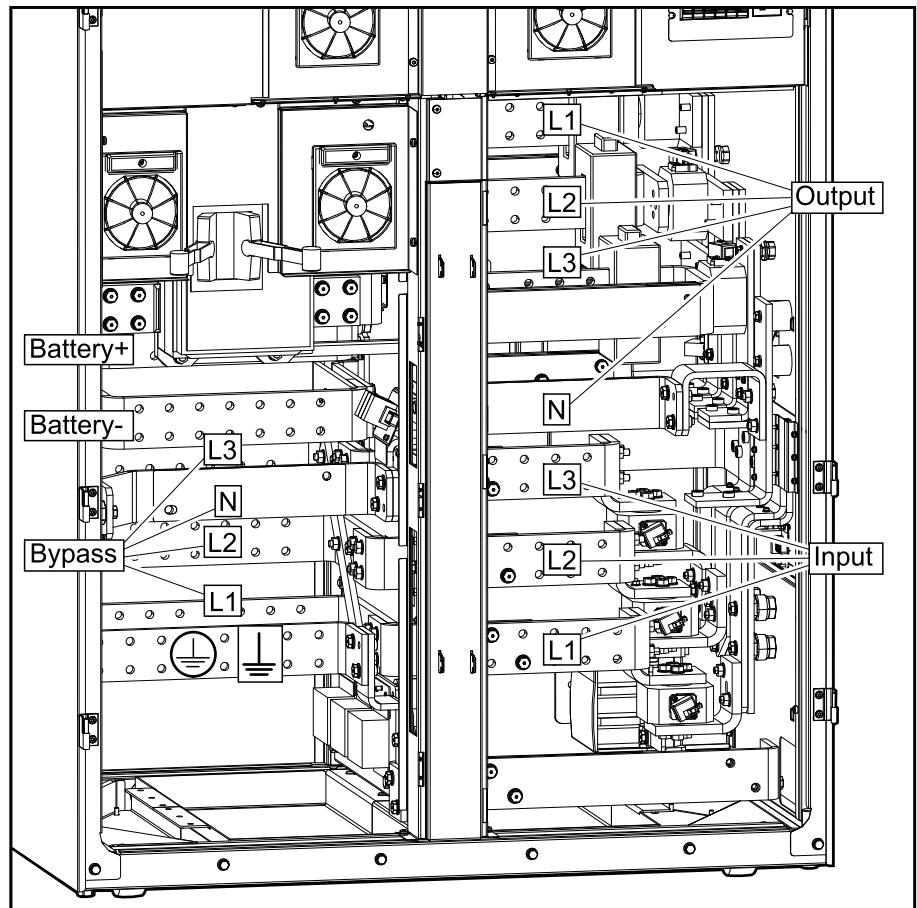

5. Connect the input cables.
6. Only applicable to dual mains systems: Connect the bypass cables.
7. Connect the output cables.
8. Connect the DC cables to the battery+ and battery- busbars.

Connect the Power Cables in a 480 V System

For 4-wire systems:

- Bonding jumper: Not connected
- Technical/system earth: No local grounding electrode connected

For 3-wire systems:

- Bonding jumper: Must be connected
- Technical/system earth: A grounding electrode must be connected via the grounding electrode conductor.

1. Only applicable to high impedance grounding systems:

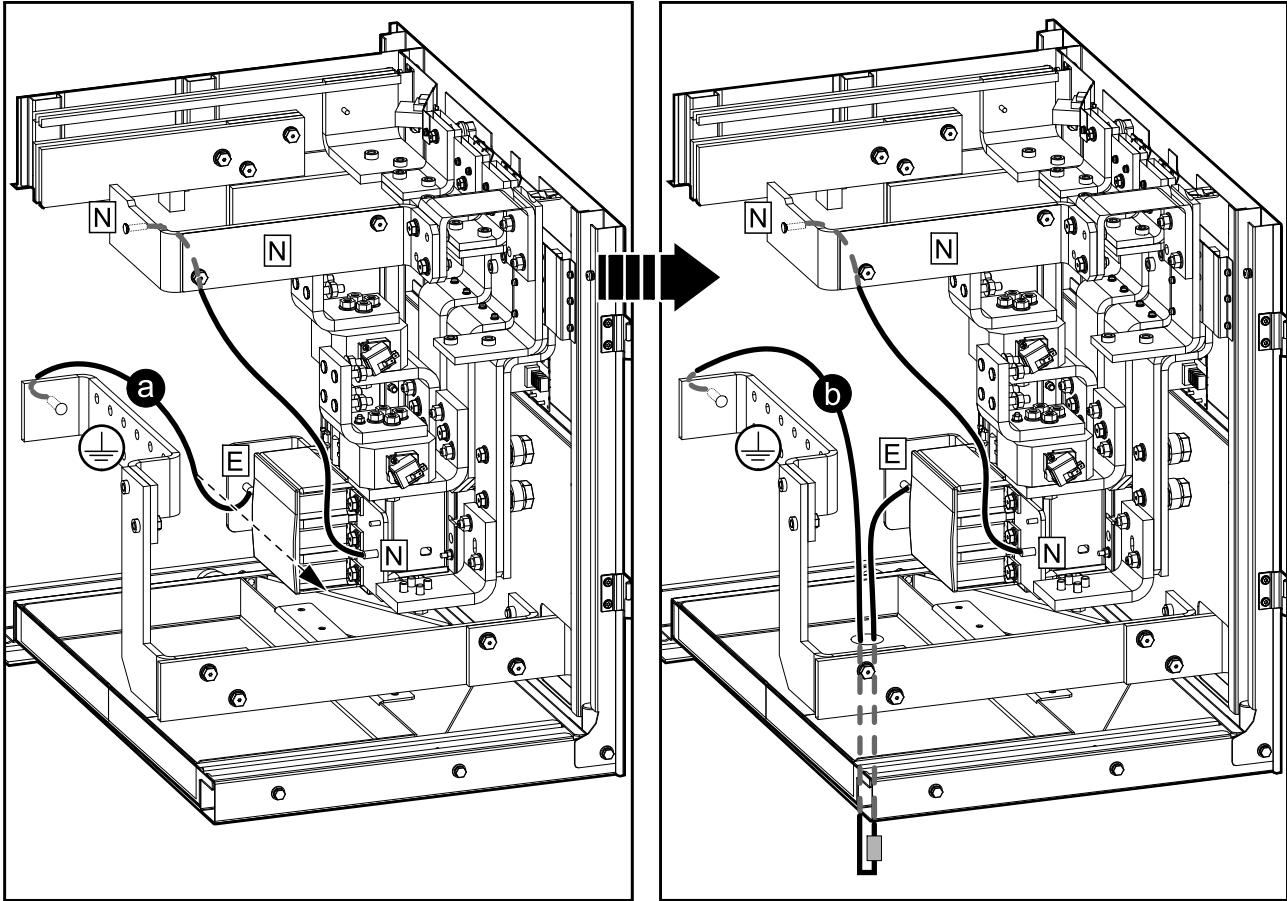

- a. Remove the jumper cable between the PE busbar and the E terminal.
- b. Connect an external impedance between the PE busbar and E terminal according to NEC 2014 article 250.36.

2. Connect the equipment grounding conductor/PE to the PE busbar.

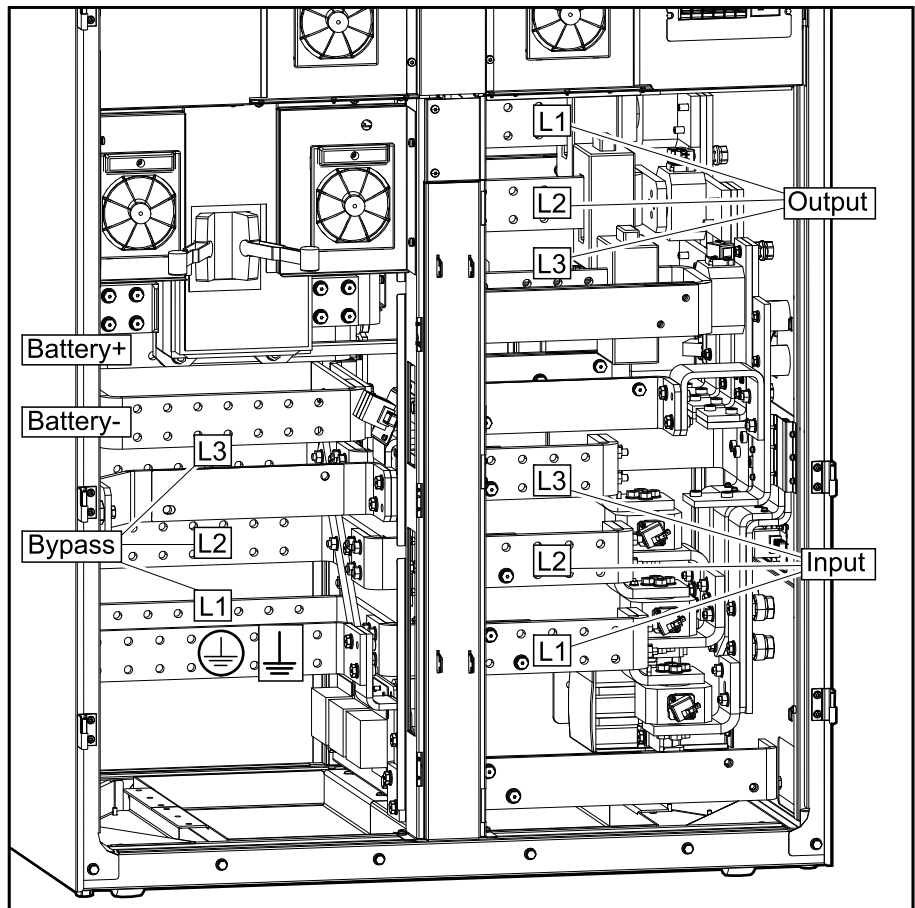

3. Connect the input cables.
4. Only applicable to dual mains systems: Connect the bypass cables.
5. Connect the output cables.
6. Connect the DC cables to the battery+ and battery- busbars.

Connect Cables to the External Supply for Li-Ion Battery Solution (Optional)

⚠ DANGER

HAZARD OF ELECTRIC SHOCK, EXPLOSION, OR ARC FLASH

Do not drill/punch holes for cables or conduits with the gland plates installed and do not drill/punch holes in close proximity to the UPS.

Failure to follow these instructions will result in death or serious injury.

The rating of the external supply breaker is 6.3 A.

Cable Sizes for External Supply

	Conductors per Phase	PE Conductor/Equipment Grounding Conductor	Conduit
Cable sizes for 400 V systems	1.5 mm ²	1.5 mm ²	NA
Cable sizes for 480 V systems ⁵⁴	1x12-18 AWG	1x18 AWG	0.5 in

1. Follow the procedure Prepare the I/O Cabinet for Power Cables in Top Cable Entry Systems, page 55 to prepare the top gland plate for cables.
2. Open the indicated door and remove the covers in front of the circuit breakers.

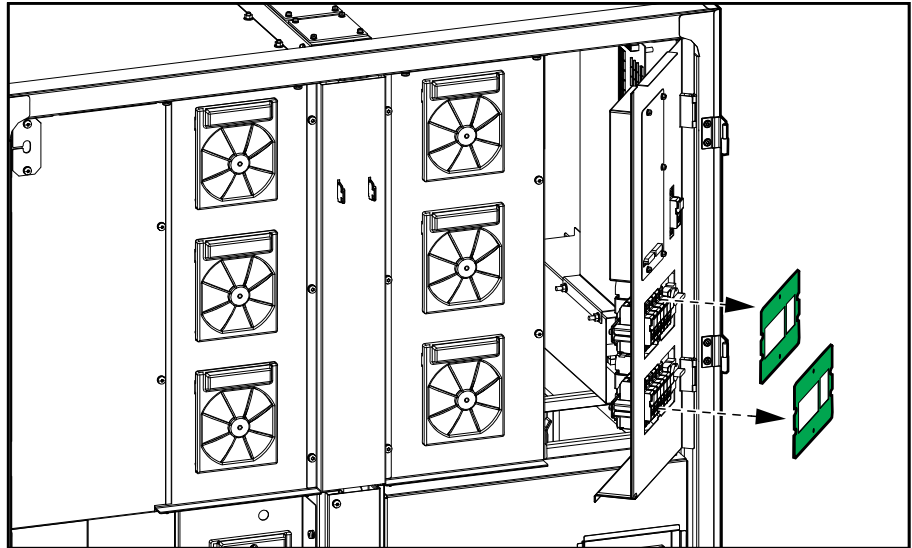

54. An external branch circuitry protection in accordance with the National Electric code NFPA 70 shall be provided externally if required by local regulations.

3. Connect the cables from the equipment to be supplied by the UPS.

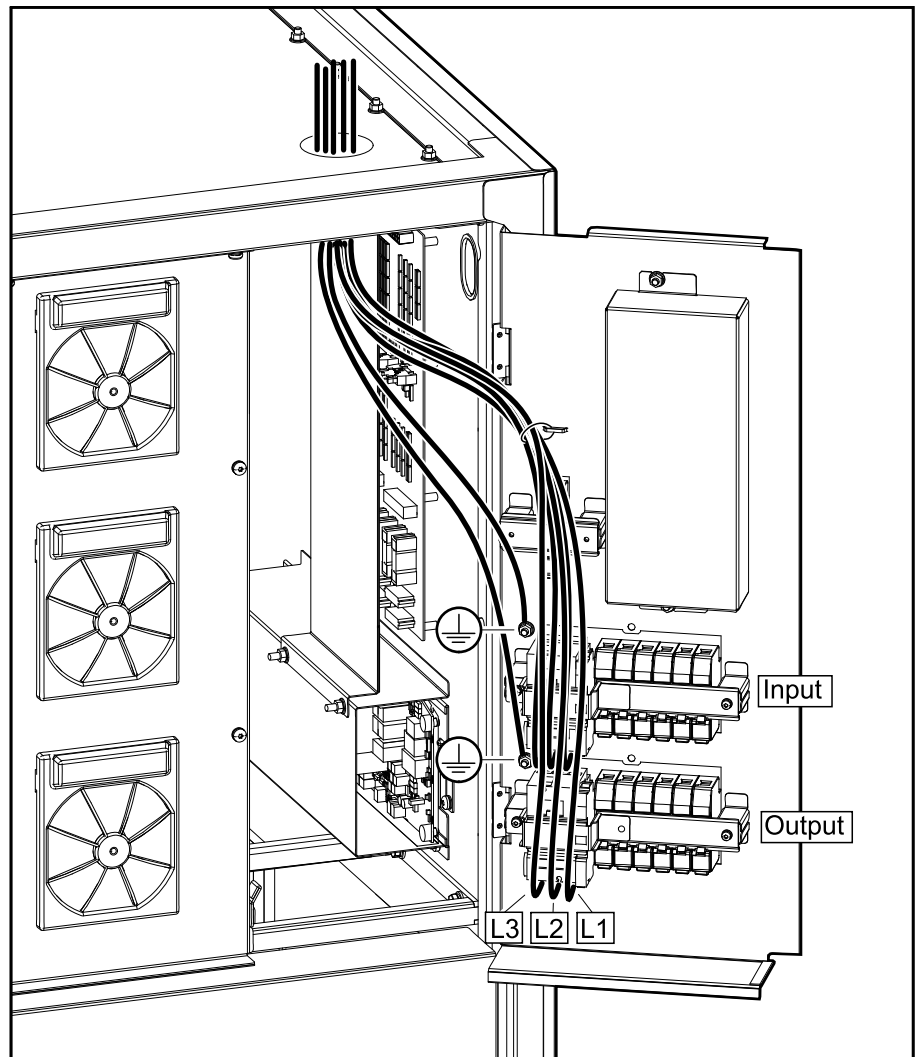

4. Reinstall the covers in front of the circuit breakers.
5. Close the door.

Mount the Front Anchoring Brackets

1. Fasten the front anchoring brackets to the front of the cabinets using the provided bolts.

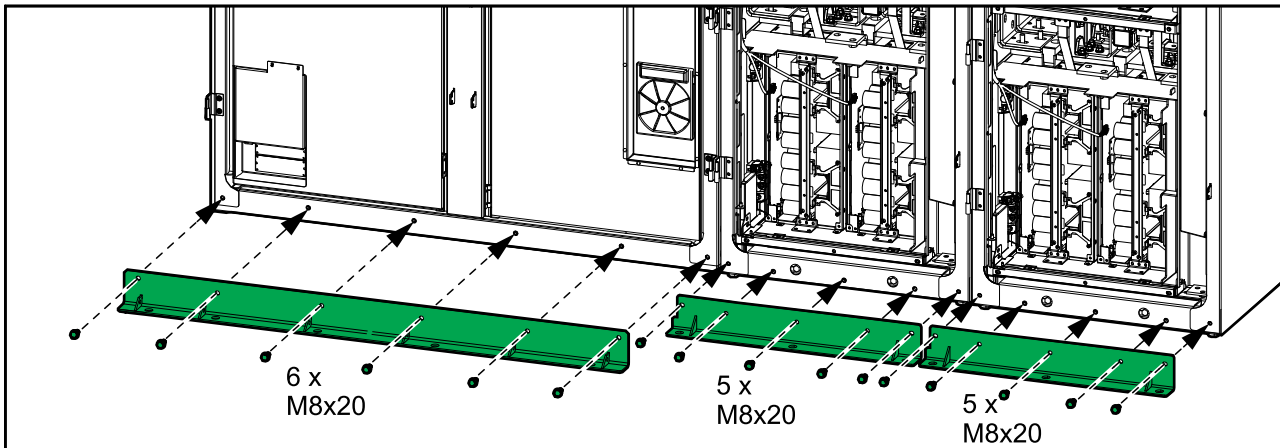

2. Anchor the front anchoring brackets to the floor.

NOTE: Floor anchoring bolts are not supplied.

Connect the Signal Cables

Connect the Signal Cables between the I/O Cabinet and the Power Cabinets

Overview of Signal Cables between the I/O Cabinet and the Power Cabinets

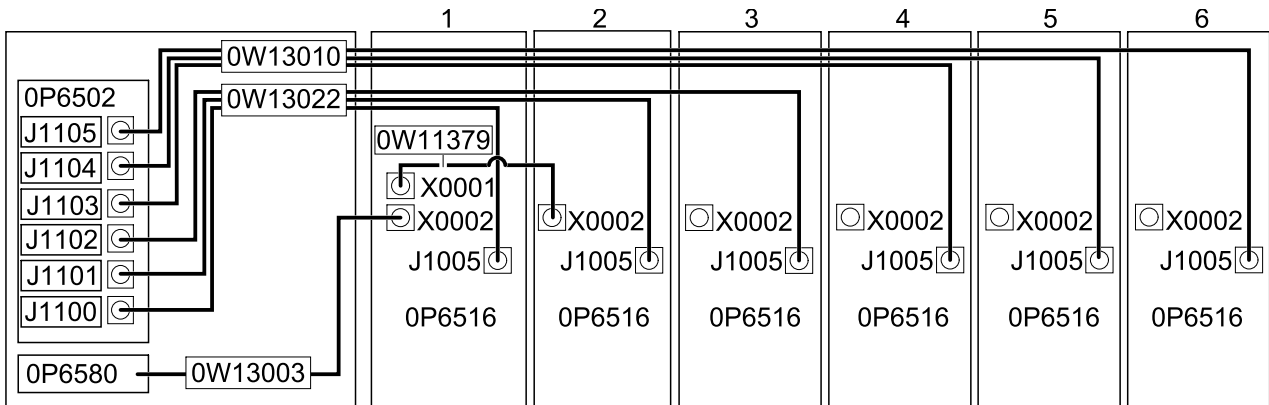

1. Remove the indicated plates from the I/O cabinet and all the power cabinets.

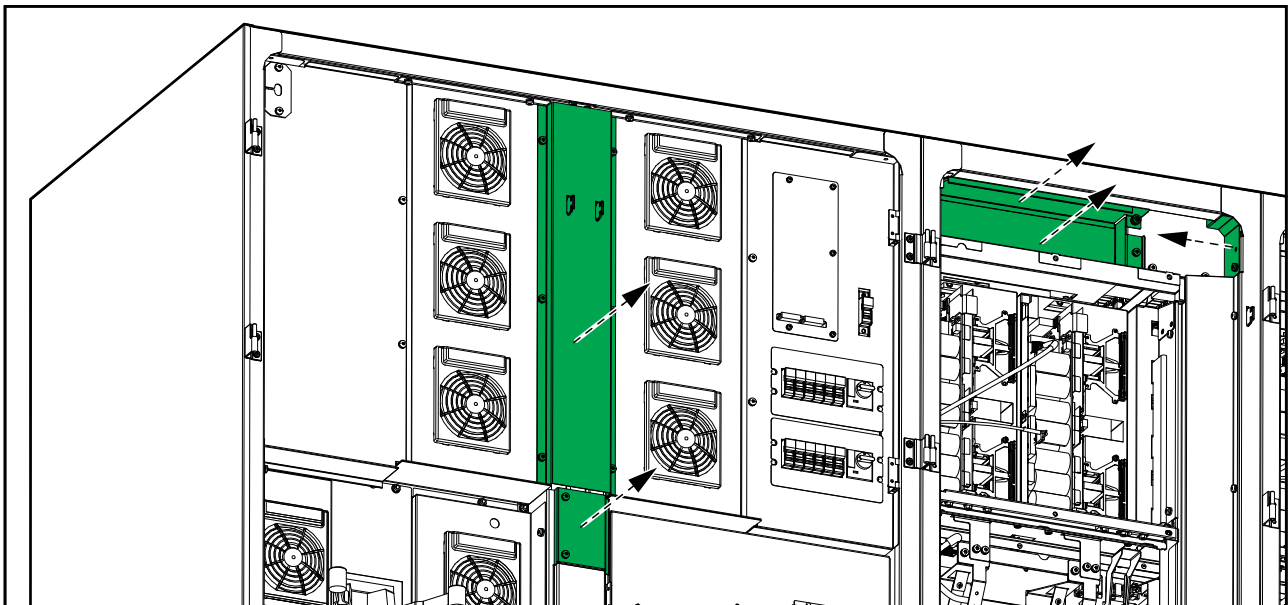

2. Connect signal cable 0W11379 from X0002 in the power cabinet 2 to X0001 in power cabinet 1.

Front View of Power Cabinet 1 and Power Cabinet 2

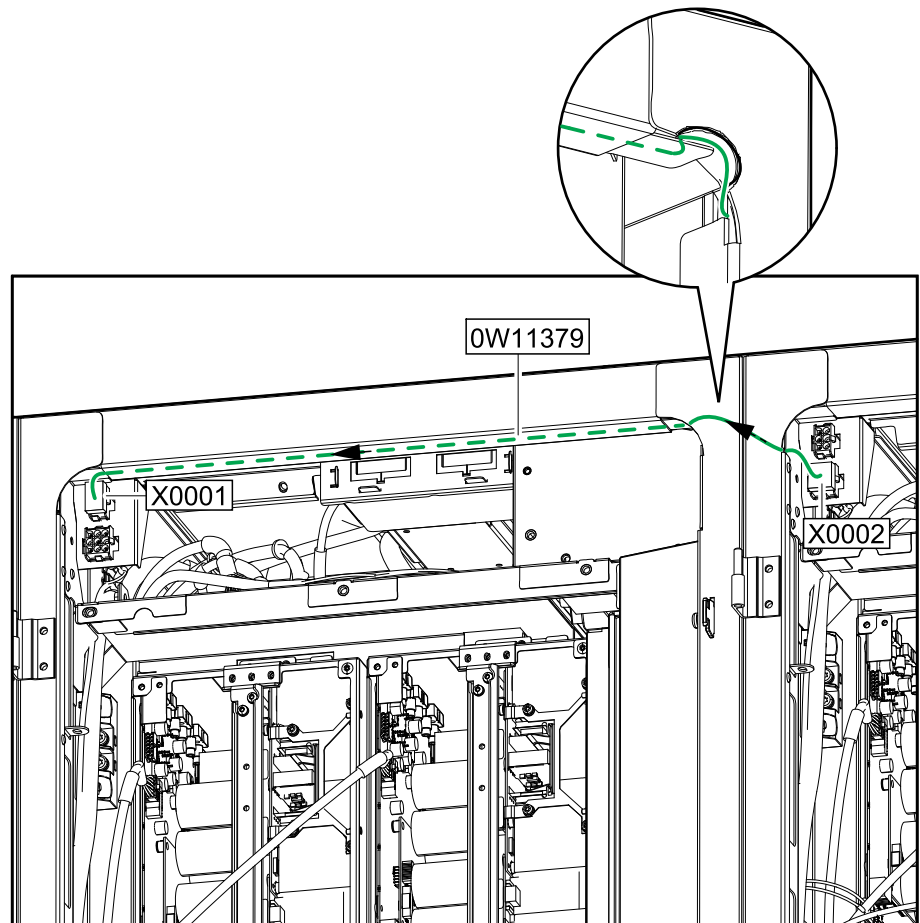

3. Connect the signal cable 0W13003 preconnected in the right side of the I/O cabinet to X0002 in power cabinet 1.

Front View of I/O Cabinet and Power Cabinet 1

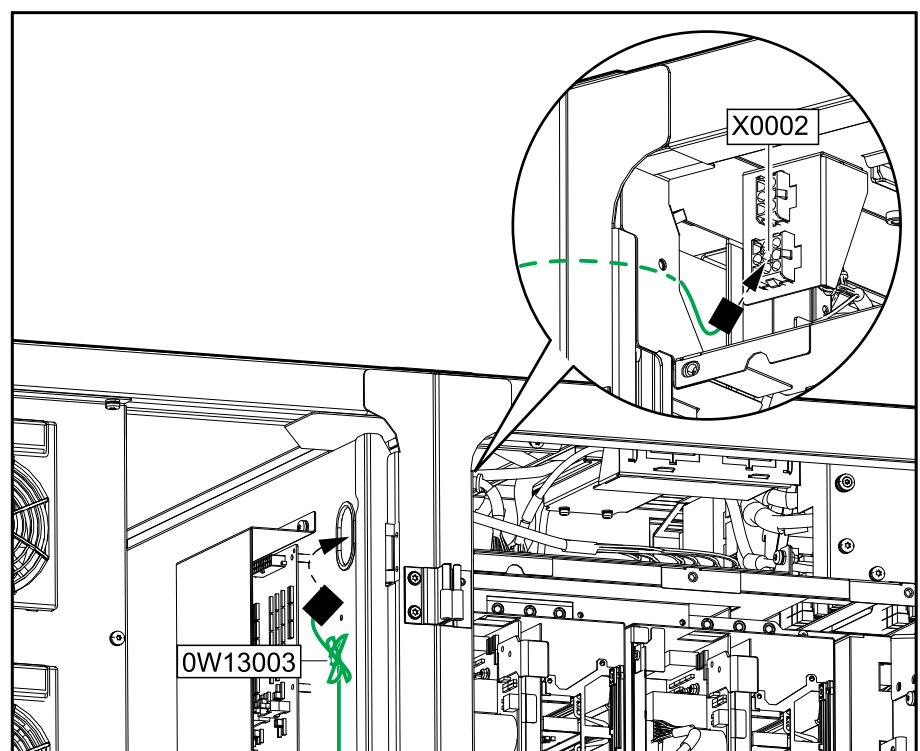

4. Open the left inner door and remove the indicated plate from the door.

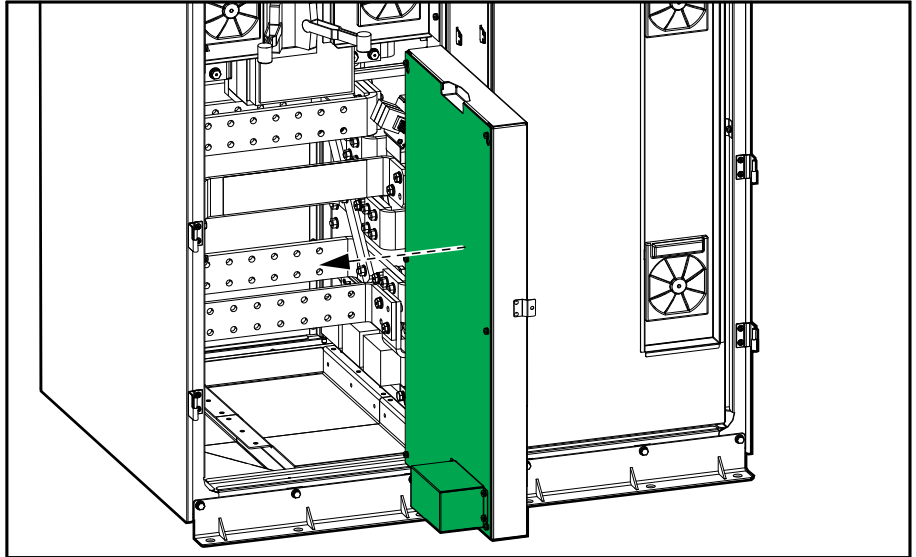

5. Connect the signal cables 0W13022 (power cabinets 1-3) and 0W13010 (power cabinets 4-6) to the J1005 terminals in the power cabinets and route the cables to the I/O cabinet.

NOTE: Minimum bending radius is 50 mm.

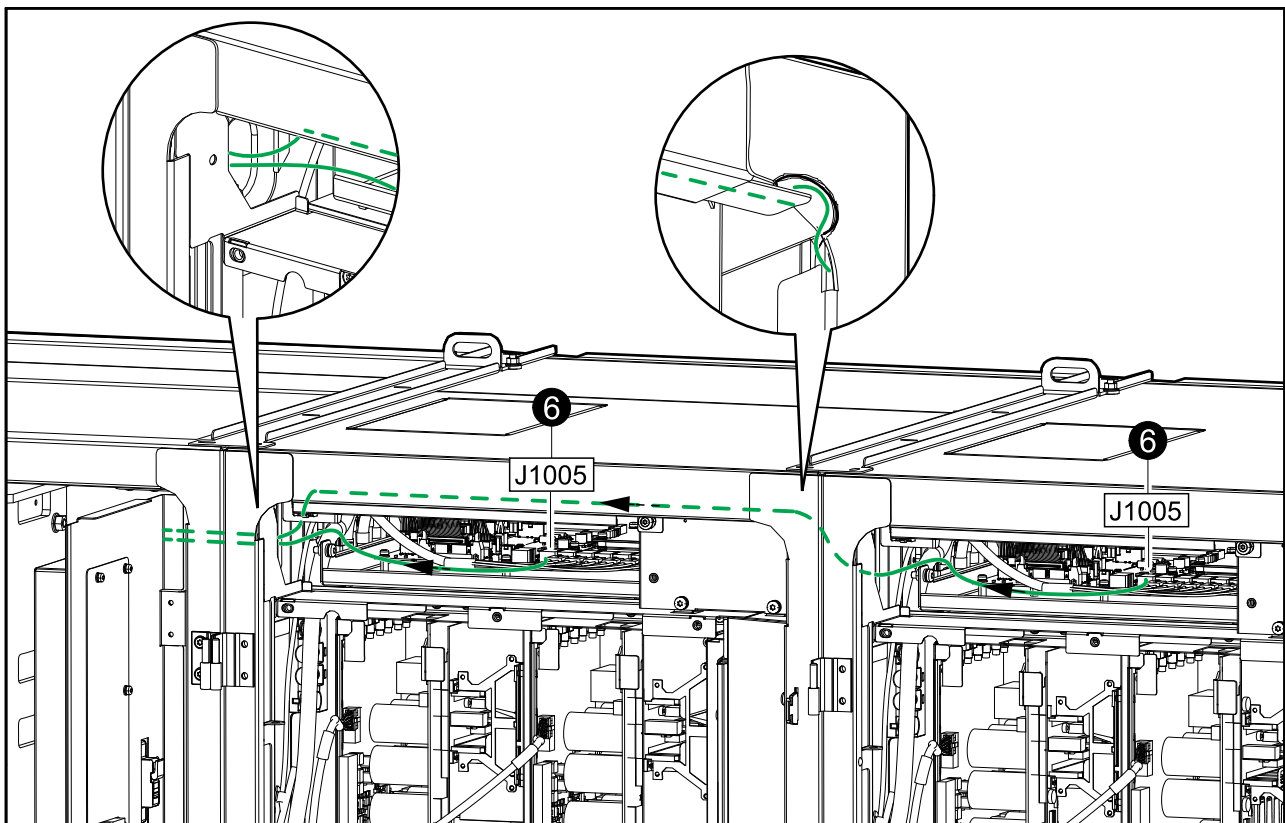

- Route the signal cables 0W13022 and 0W13010 to the board 0P6502 in the left door and connect the cables to the terminals as shown in the diagram Overview of Signal Cables between the I/O Cabinet and the Power Cabinets, page 67.

NOTE: Remove and dispose of the plastic plate covering the terminals.

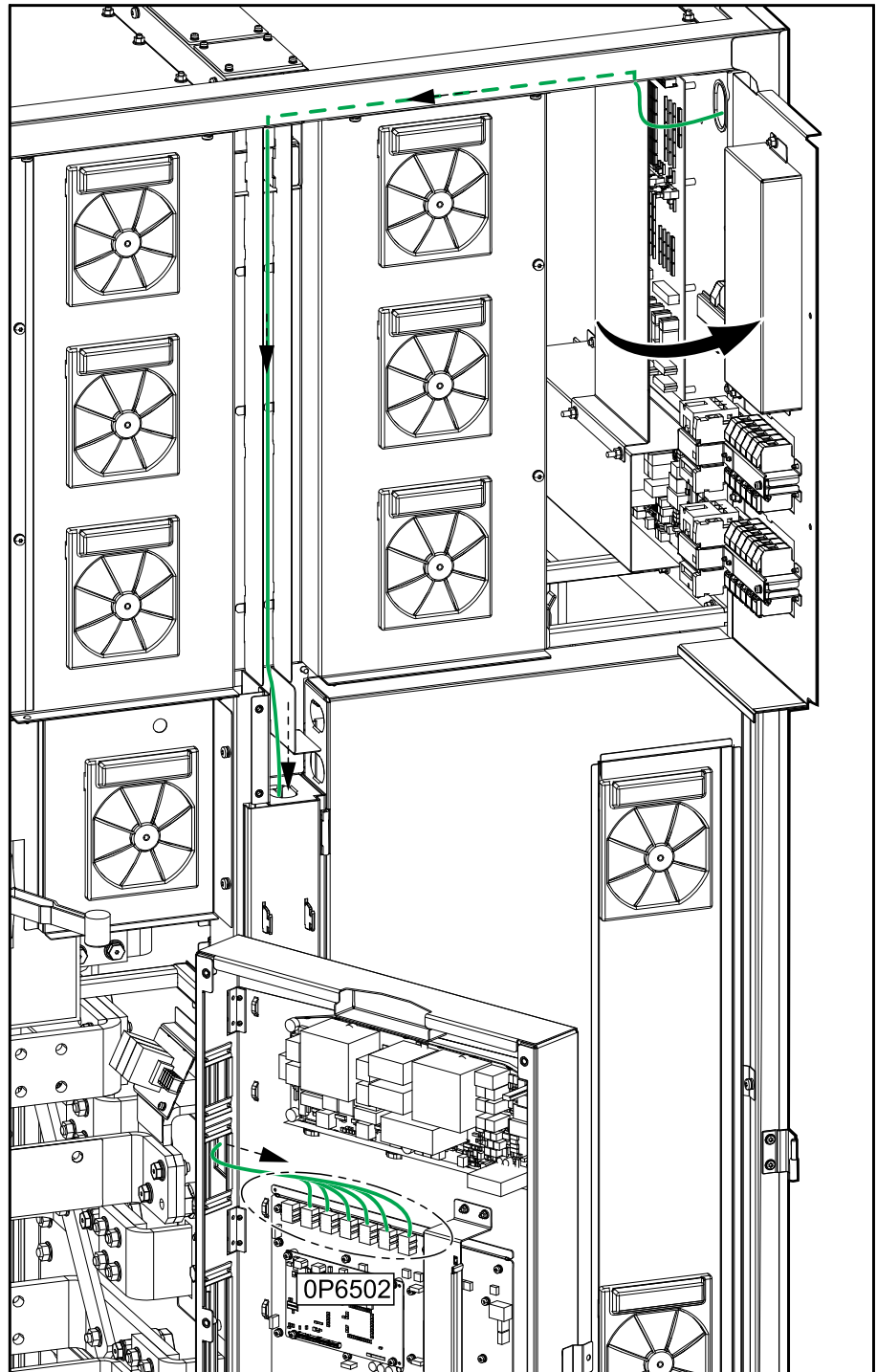

Overview of Board Locations for External Signal Cables

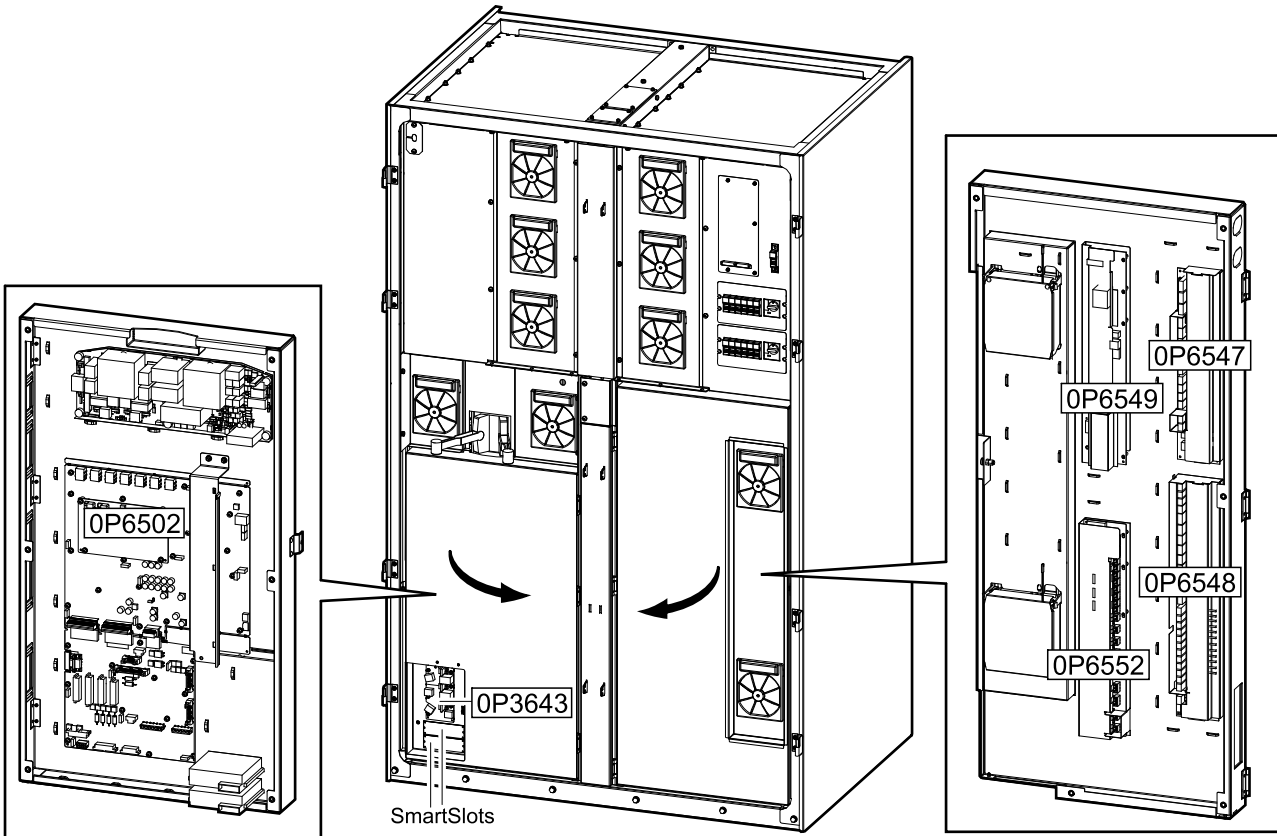

Follow the procedure [Route External Signal Cables to the Boards](#), page 72 for information on how to route the external signal cables to the boards.

For information on the signal cable connections go to:

- [Overview of Input Contacts and Output Relays](#), page 75.
- [Signal Cable Connections to the Switchgear \(Boards OP6547, OP6548, OP6549\)](#), page 77.
- [Signal Cable Connections to Classic Battery Cabinets \(Boards OP6547, OP6549, OP6552\)](#), page 78.
- [Signal Cable Connections to Battery Breaker Cabinet \(Boards OP6547, OP6548, OP6549\)](#), page 79.
- [PBUS Cable Connections \(Board OP3643\)](#), page 79.
- [Modbus Connections \(Board OP6502\)](#), page 80.
- [Signal Cable Connections for Basic UPS Synchronization to a Fixed Voltage Source \(Boards OP6548, OP6549\)](#), page 82.
- [Signal Cable Connections for Dual UPS Synchronization with a Floating Synchronization Master \(Boards OP6548, OP6549\)](#), page 83.
- [Signal Cable Connections for Fixed Parallel Synchronization Master \(Boards OP6548, OP6549\)](#), page 84.

Route External Signal Cables to the Boards

1. Remove the two gland plates from the top of the I/O cabinet and drill holes for the applicable Class 2/SELV (A) and non-Class 2/non-SELV (B) signal cables. Install conduits and reinstall the plates.

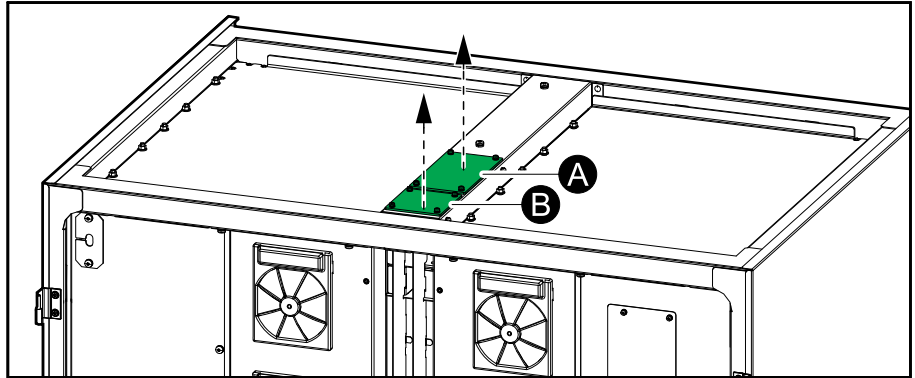

2. Route the external signal cables through the cable channel and through the correct openings:
 - A. Class2/SELV cables to the boards in the left door.
 - B. Class2/SELV cables to the boards in the right door.
 - C. Non-class 2/Non-SELV cables to the boards in the right door.

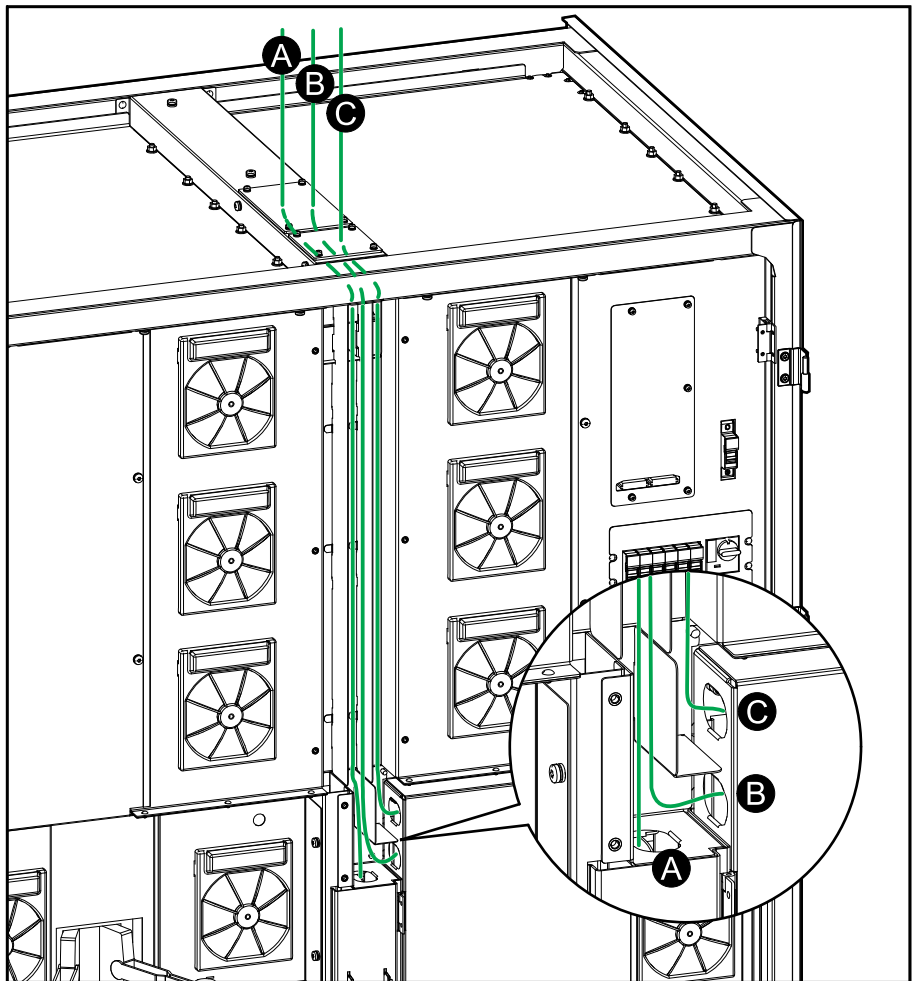

3. Route the external signal cables to the boards in the right door:
 - a. Open the right door and remove the plate from the inner door.

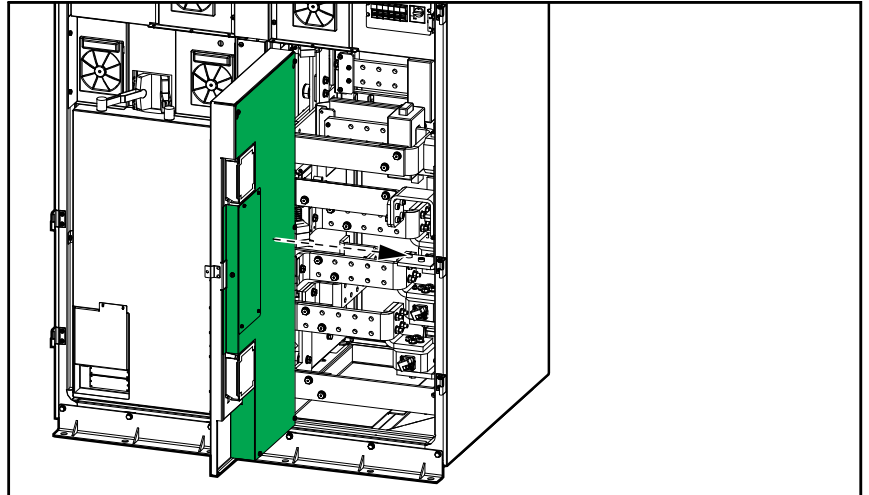

- b. Route the cables to the board terminals and fasten with the provided cable ties. Class 2/SELV cables (A) must be routed separated from non-Class 2/non-SELV cables (B) as shown on the illustration.

NOTE: The external signal cables must be long enough for the door to fully open.

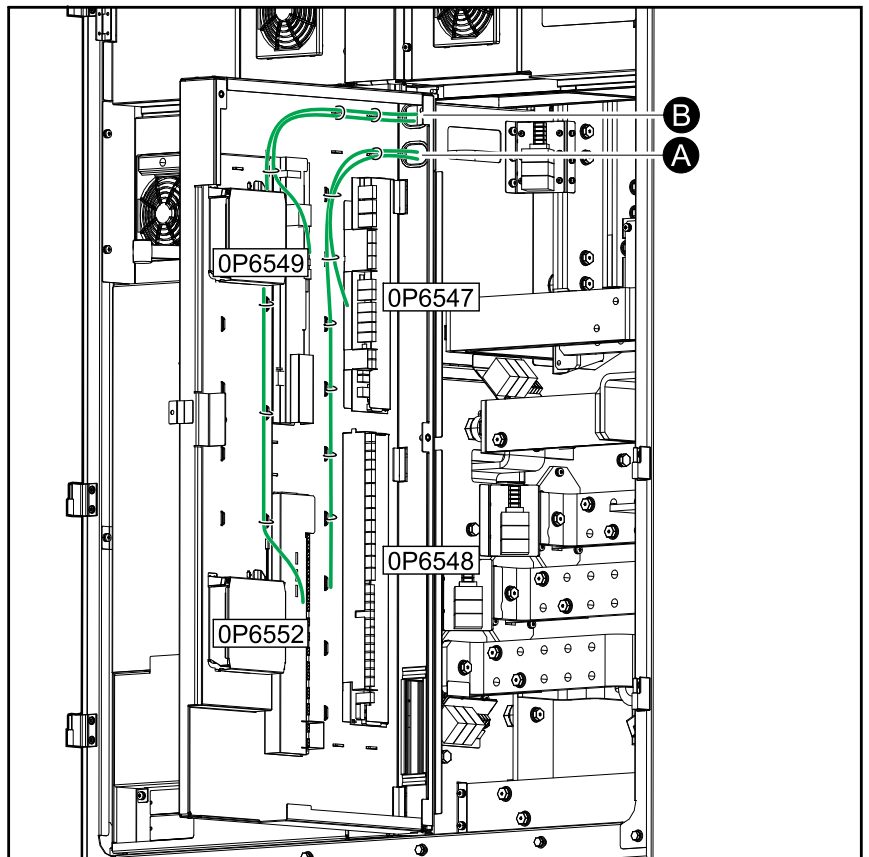

4. Route the external signal cables to the boards in the left door:
 - a. Open the left door and remove the plate from the inner door.

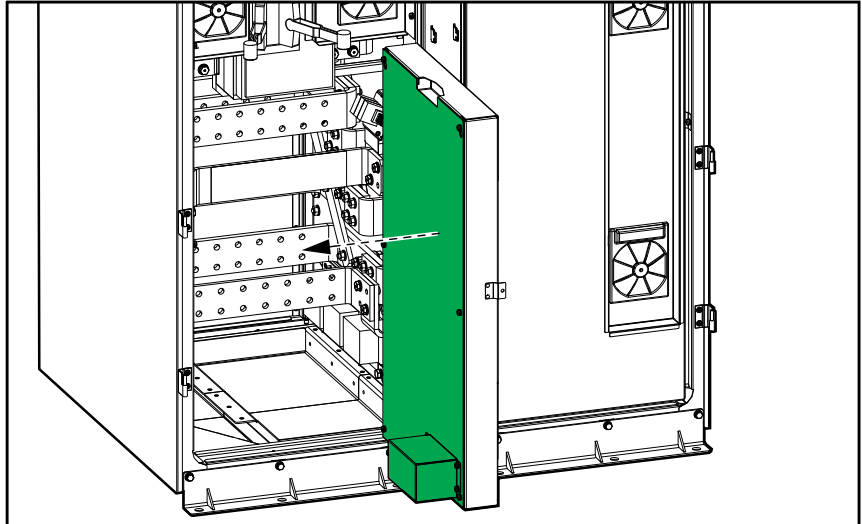

- b. Route the external signal cables to the terminals and fasten with the provided cable ties.

NOTE: The external signal cables must be long enough for the doors to fully open.

NOTE: Use the plate (A) for shielding of the Modbus cable.

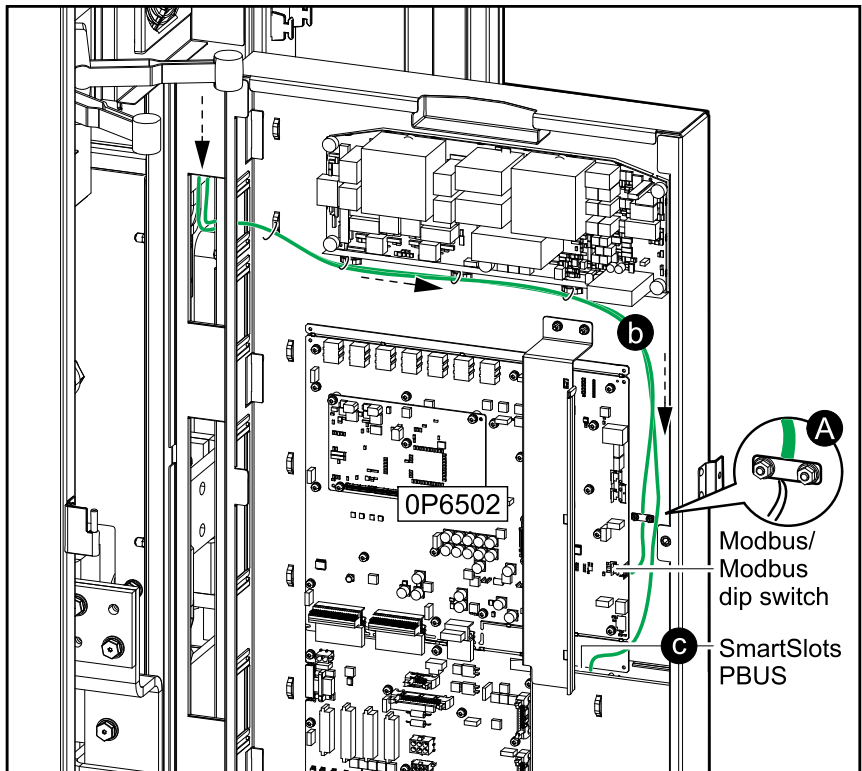

- c. Close the door and route the PBUS cables and cables for the network management cards to the front.

NOTE: If the input dry contact AP9810 is connected to AP9631 or AP9635CH, the total length of cables for connected equipment must not exceed 30 m (98 ft). Use the plate for shielding (A).

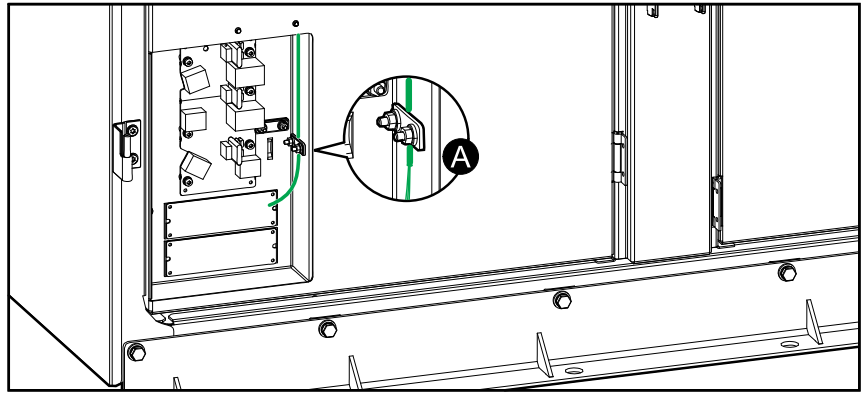

Overview of Input Contacts and Output Relays

Input Contacts

Do not connect any circuit to the input contacts unless it can be confirmed that the circuit is Class 2/SELV.

All circuits connected must have the same 0 V reference.

The switch SW5500 on 0P6548 is used to select between internal SELV supply for inputs (standard setting) and external supply⁵⁵. If external supply is selected, the supply must be connected to J5530.

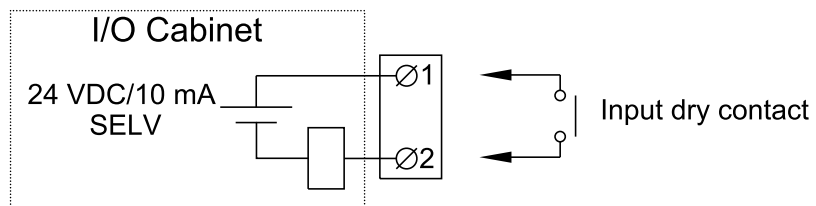

Name	Description	Location
IN 1 (Contact 1)	Configurable input contact	0P6548 terminal J5502 ⁵⁶
IN 2 (Contact 2)	Configurable input contact	0P6548 terminal J5503 ⁵⁶
IN 3 (Contact 3)	Configurable input contact	0P6548 terminal J5504 ⁵⁶
IN 4 (Contact 4)	Configurable input contact	0P6548 terminal J5505 ⁵⁶
IN 5 (Contact 5)	Configurable input contact	0P6548 terminal J5510 ⁵⁶
IN 6	UOB redundant AUX contact	0P6548 terminal J5509 ⁵⁶
IN 7	Transformer temperature switch	0P6548 terminal J5508 ⁵⁶
IN 8	External bonding contact	0P6548 terminal J5507 ⁵⁶
IN 9	Forced external synchronization input	0P6548 terminal J5506 ⁵⁶
IN 10	External synchronization requested	0P6548 terminal J5511 ⁵⁶
IN 11	Use static bypass standby	0P6548 terminal J5512 ⁵⁶
IN 14	MegaTie	0P6552 terminal J9027 ⁵⁶

Output Relays

NOTE: Maximum 250 VAC 5 A must be connected to the output relays.

All external circuitry must be fused with maximum 5 A fast acting fuses.

55. An external supply is useful in parallel systems where inputs are connected between different UPSs. This is to have a common reference and to avoid cross currents.

56. Class 2/SELV wiring

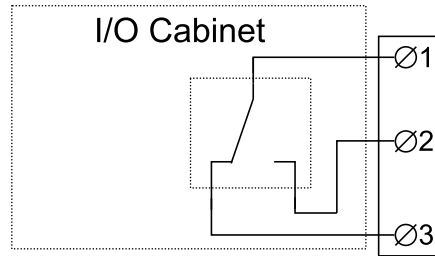

Output relay connection
 Max 5 A/250 VAC
 Max 5 A/24 VDC

Name	Description	Location
OUT 1 (Relay 1)	Configurable output relay	0P6547 terminal J4939
OUT 2 (Relay 2)	Configurable output relay	0P6547 terminal J4940
OUT 3 (Relay 3)	Configurable output relay	0P6547 terminal J4941
OUT 4	Forced external synchronization output	0P6548 terminal J5520 ⁵⁷
OUT 5	MegaTie	0P6548 terminal J5521 ⁵⁷
OUT 6	External synchronization requested output	0P6548 terminal J5522 ⁵⁷
OUT 7	UPS in inverter ON	0P6548 terminal J5523 ⁵⁷
OUT 8 (Relay 4)	Configurable output relay	0P6548 terminal J5524 ⁵⁷
OUT 9 (Relay 5)	Configurable output relay	0P6548 terminal J5525 ⁵⁷
OUT 10 (Relay 6)	Configurable output relay	0P6548 terminal J5528 ⁵⁷
OUT 14	Bonding contactor	0P6552 terminal J9029 ⁵⁷

NOTE: Refer to the operation manual for configuration options.

⁵⁷. Class 2/SELV wiring

Signal Cable Connections to the Switchgear (Boards 0P6547, 0P6548, 0P6549)

NOTE: The unit output breaker UOB must include two separated AUX switches.

NOTE: The solenoid key release unit (SKRU) is only applicable to 480 V systems.

All circuits connected must have the same 0 V reference.

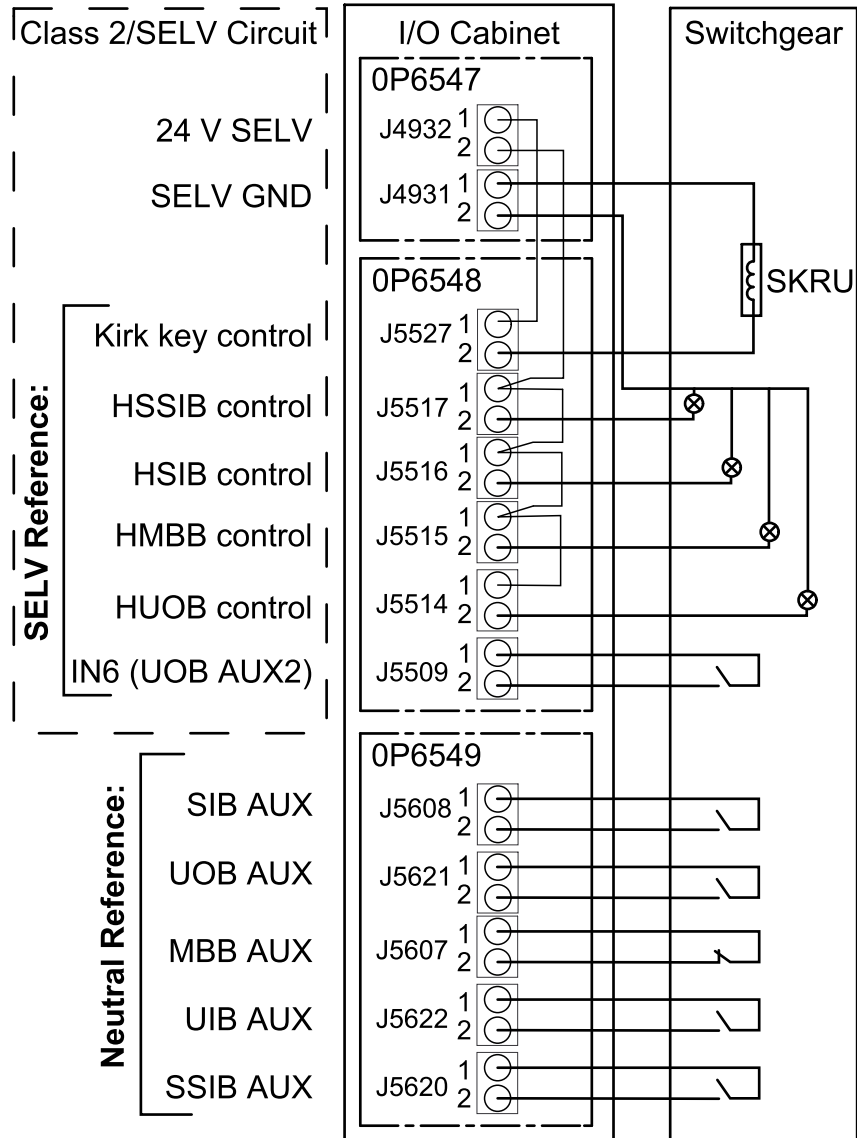

Signal Cable Connections to Classic Battery Cabinets (Boards 0P6547, 0P6549, 0P6552)

NOTE: The illustration below shows a system with four battery banks, each consisting of one classic battery cabinet. Connect signal cables according to the number of classic battery cabinets in your installation.

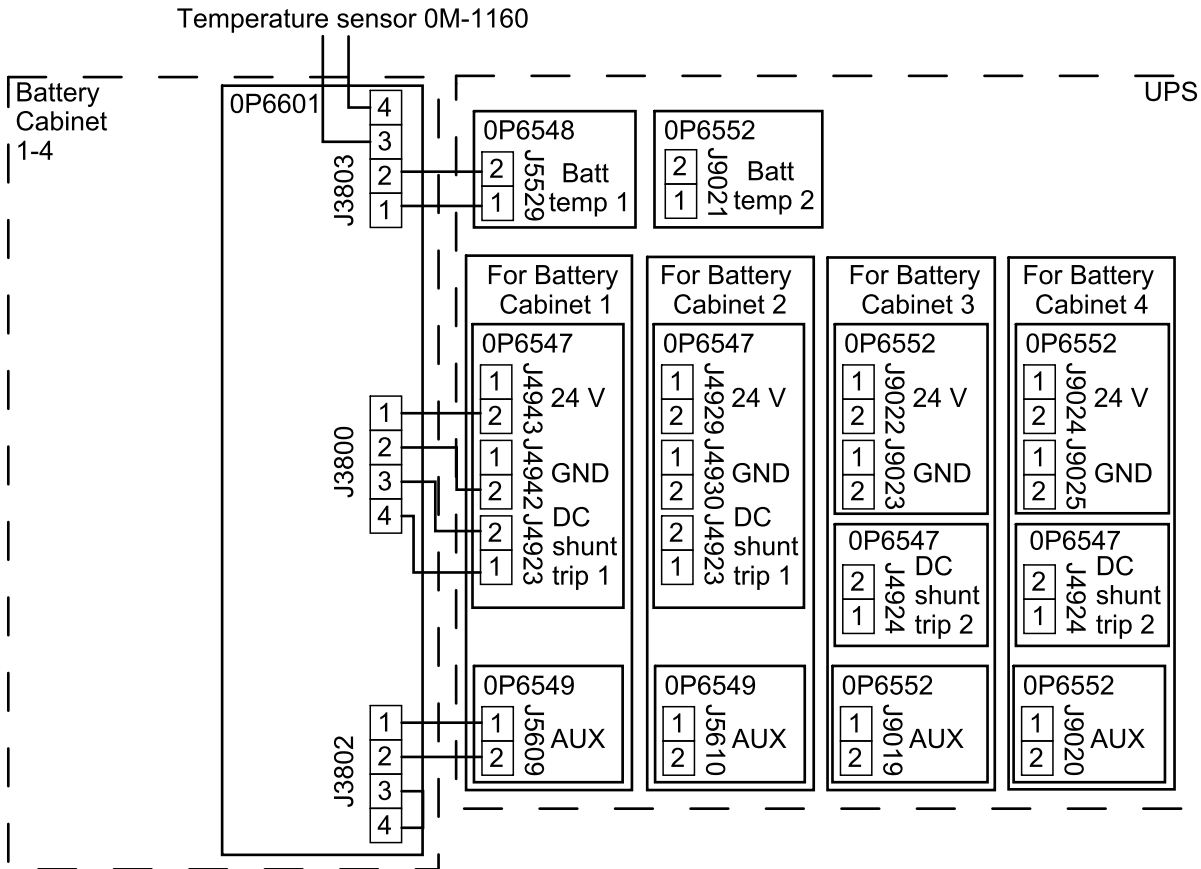

If the battery bank is consisting of two classic battery cabinets, connect signal cables between the two classic battery cabinets in one battery bank as shown.

Battery Bank

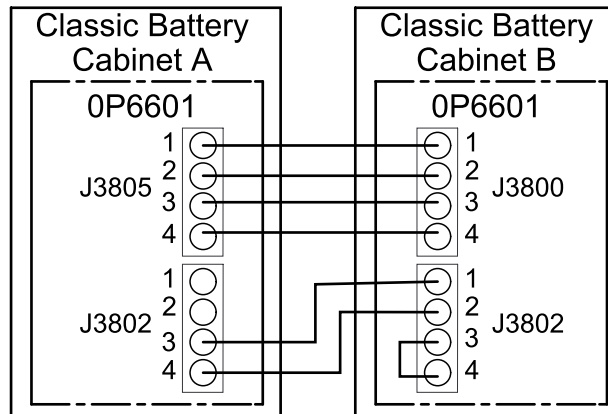

Signal Cable Connections to Battery Breaker Cabinet (Boards 0P6547, 0P6548, 0P6549)

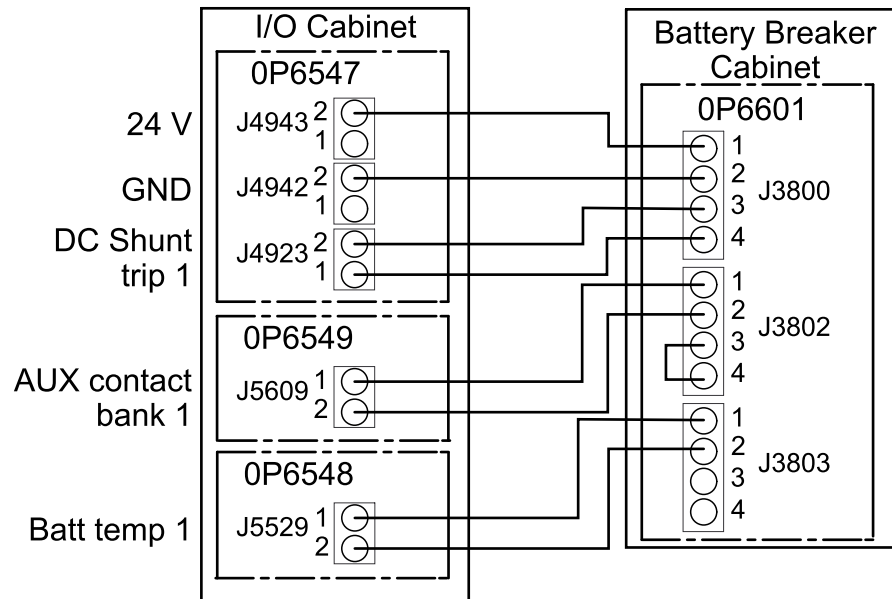

PBUS Cable Connections (Board 0P3643)

NOTE: The PBUS 1 cables are white and the PBUS 2 cables are red.

NOTE: The total length of the PBUS cables must not exceed 60 m (197 ft).

Example of System with Four UPSs in Parallel

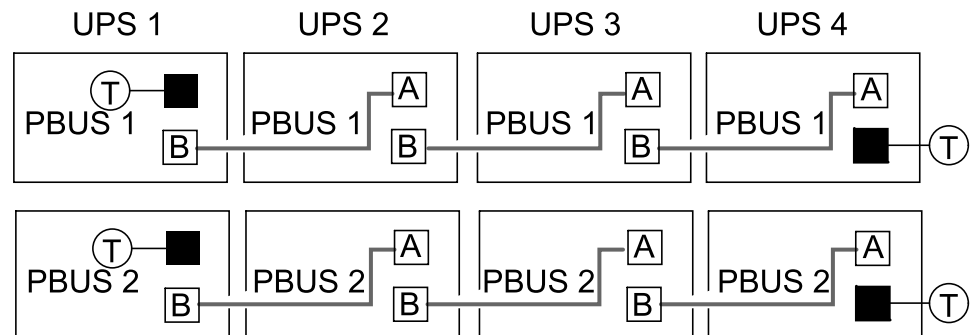

Modbus Connections (Board 0P6502)

NOTE: Terminators for Modbus connection is provided in installation kit 0H-9385.

NOTE: Shielded cables must be used for Modbus connections. The shield connection to the ground must be as short as possible (ideally below 1 cm)

2-Wire Connection with One UPS

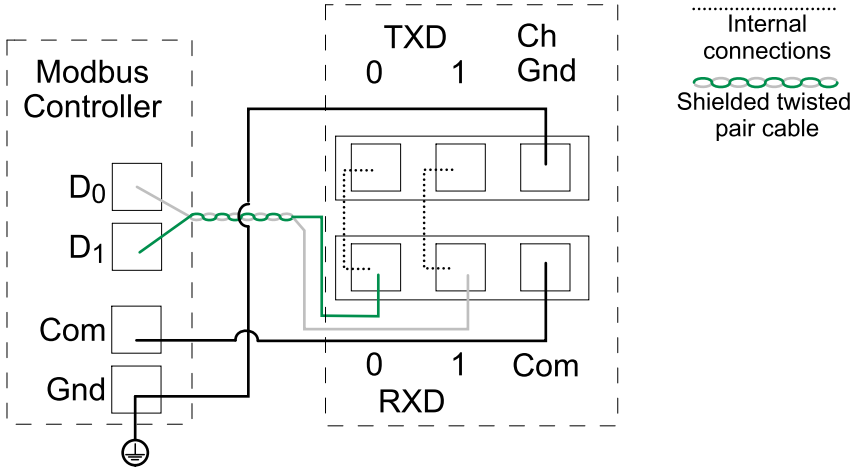

Example: 2-Wire Connection with Two UPSs

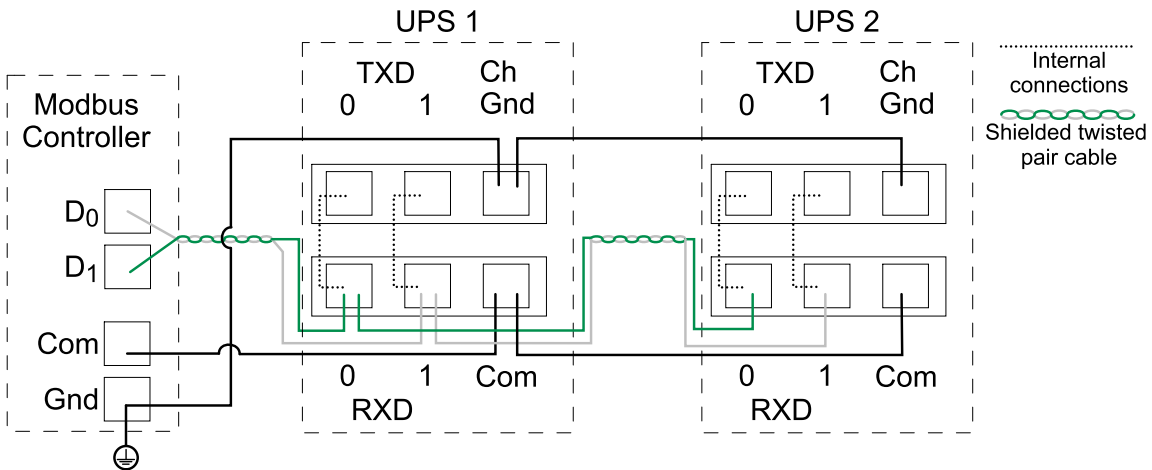

Example: 4-Wire Connection with One UPS

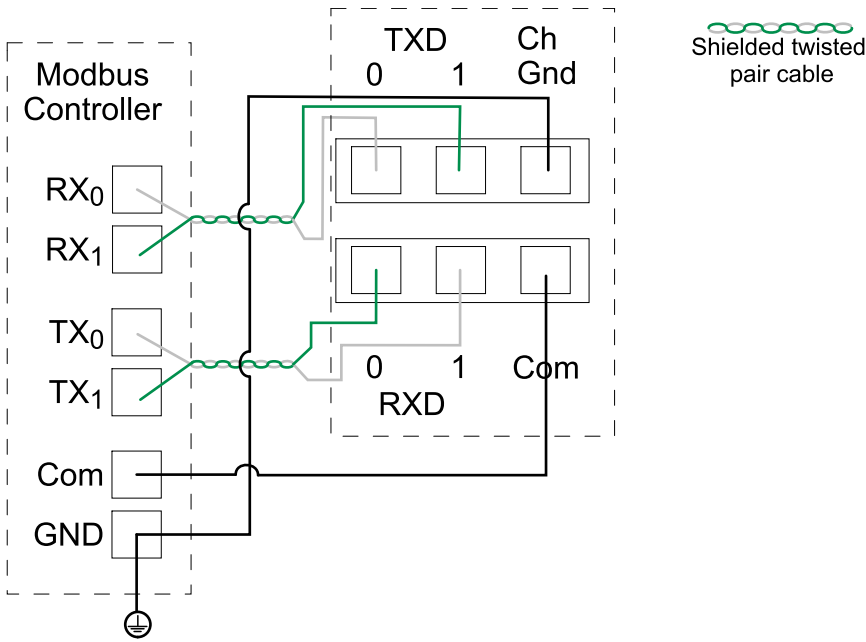

Example: 4-Wire Connection with Two UPSs

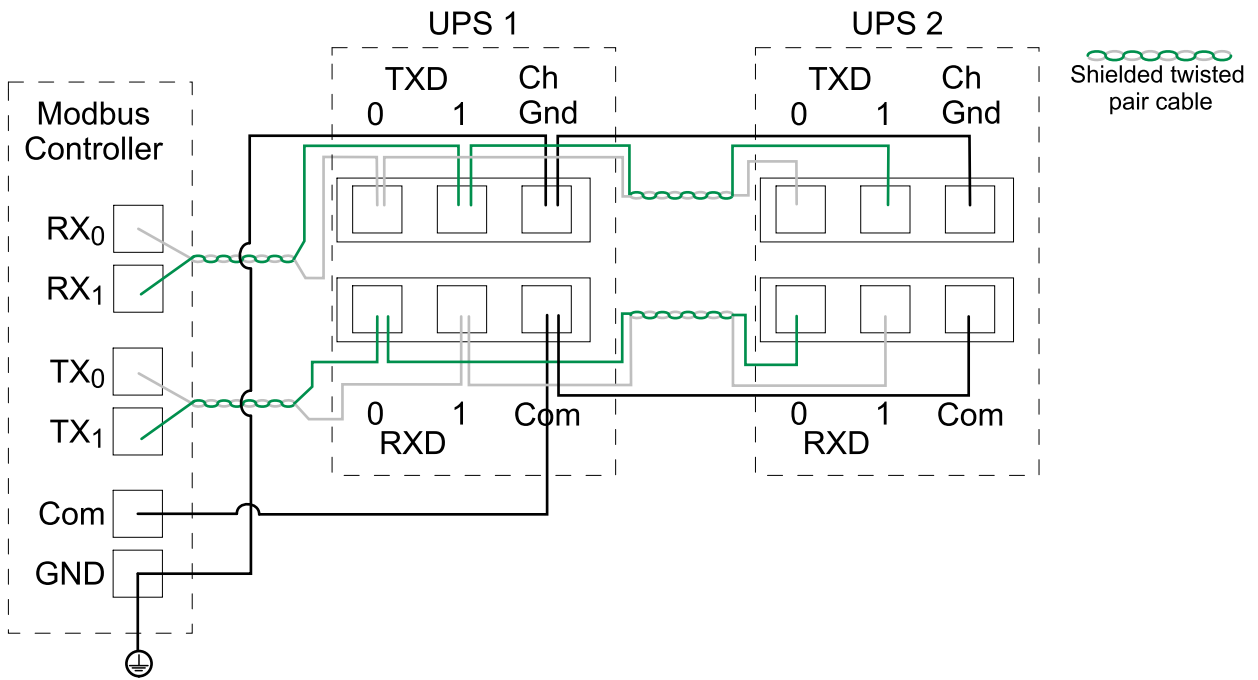

Modbus Dip Switch Settings

The Modbus dip switches must be set to match your installation:

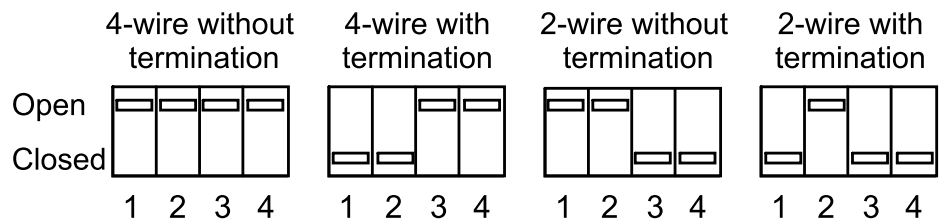

Signal Cable Connections for Basic UPS Synchronization to a Fixed Voltage Source (Boards 0P6548, 0P6549)

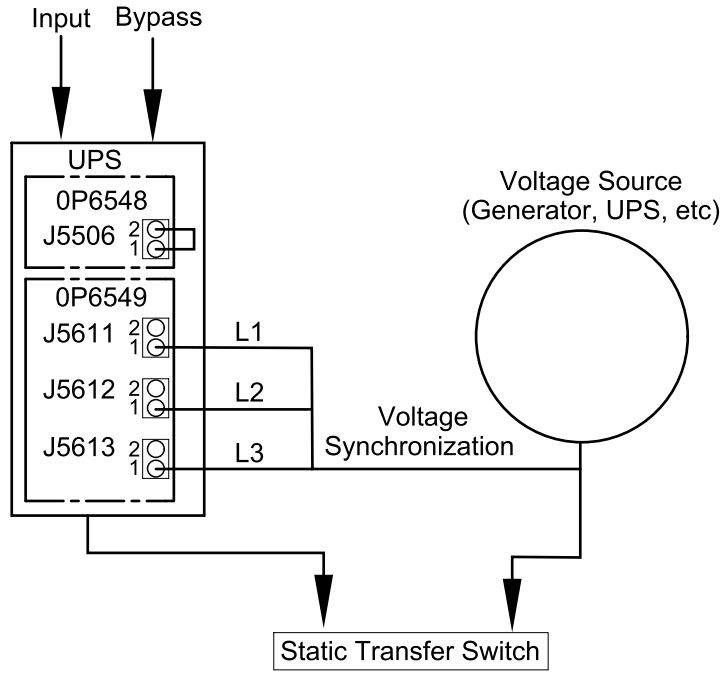

Signal Cable Connections for Dual UPS Synchronization with a Floating Synchronization Master (Boards 0P6548, 0P6549)

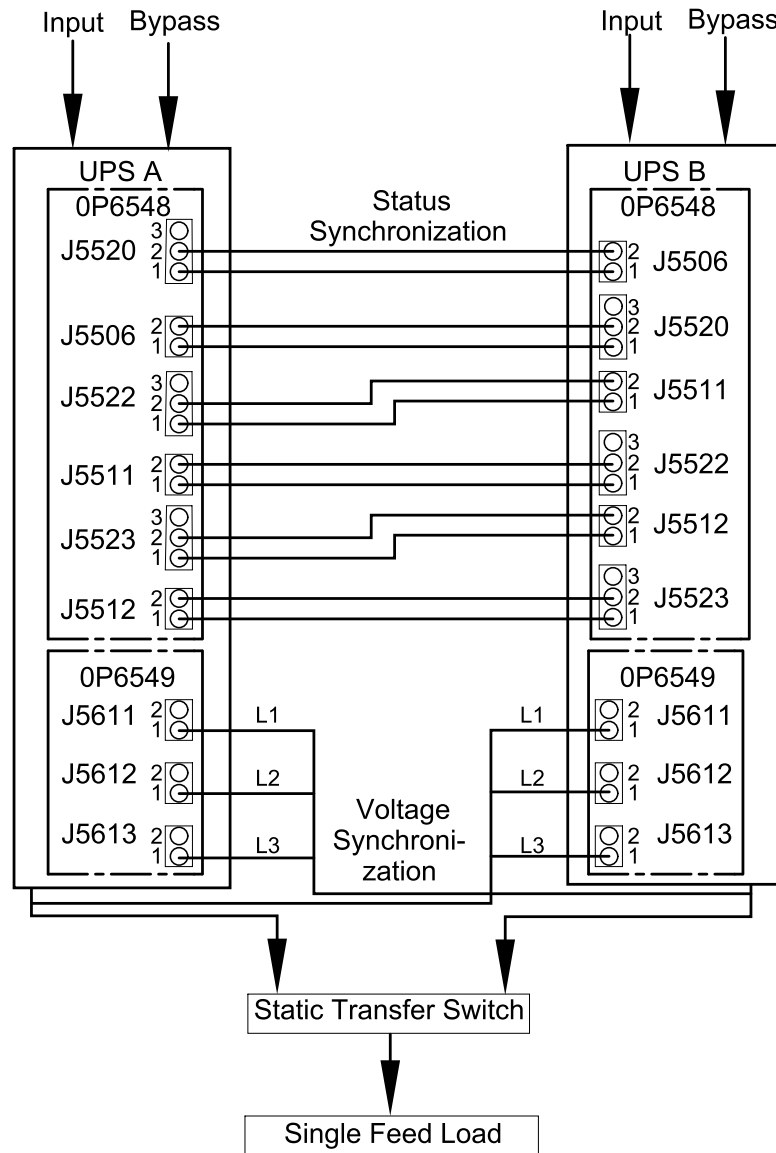

Signal Cable Connections for Fixed Parallel Synchronization Master (Boards 0P6548, 0P6549)

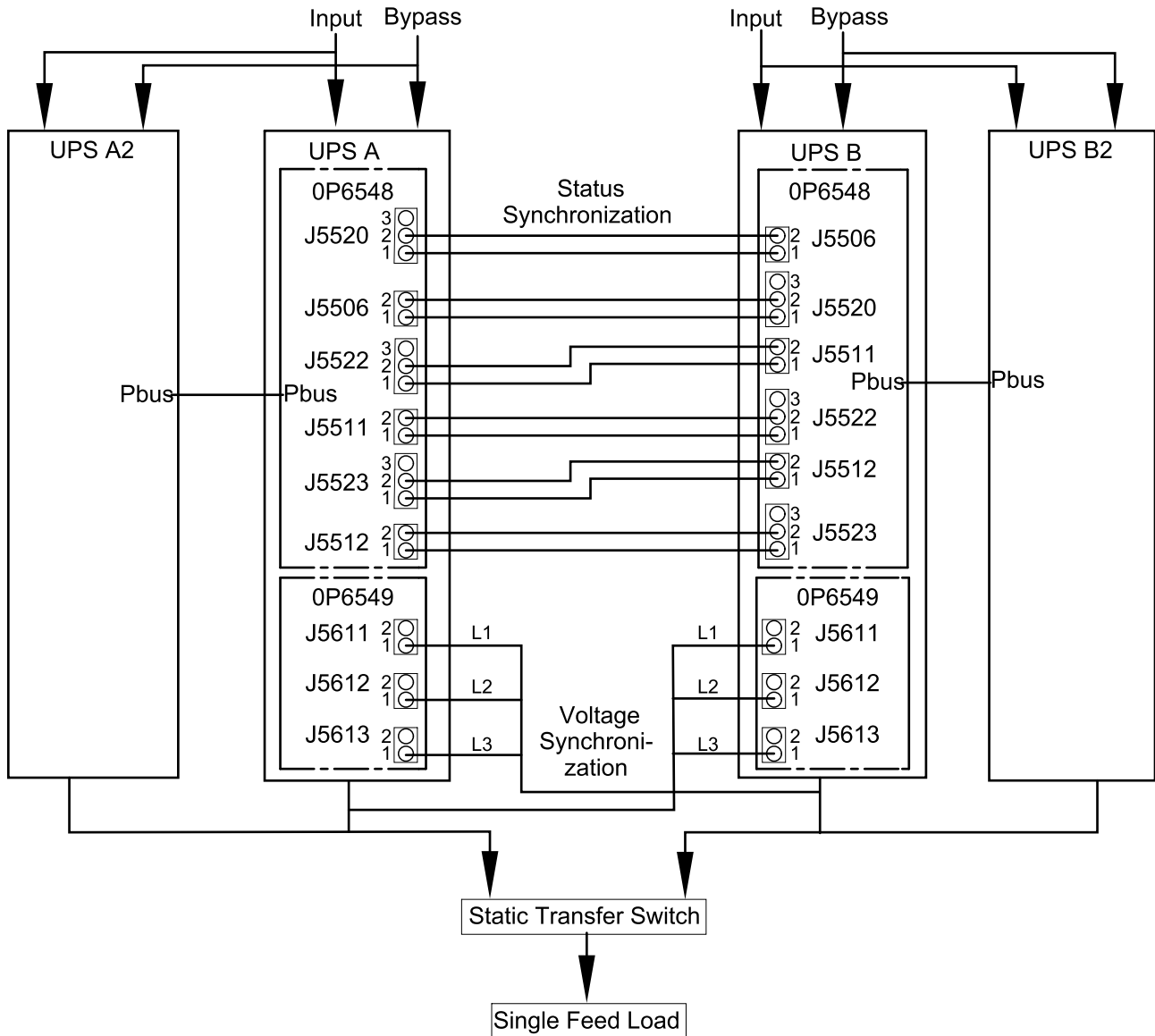

Final Mechanical Assembly

Final Mechanical Assembly of the I/O Cabinet

1. Reinstall the cover on the door in the left side and fasten with the screws.

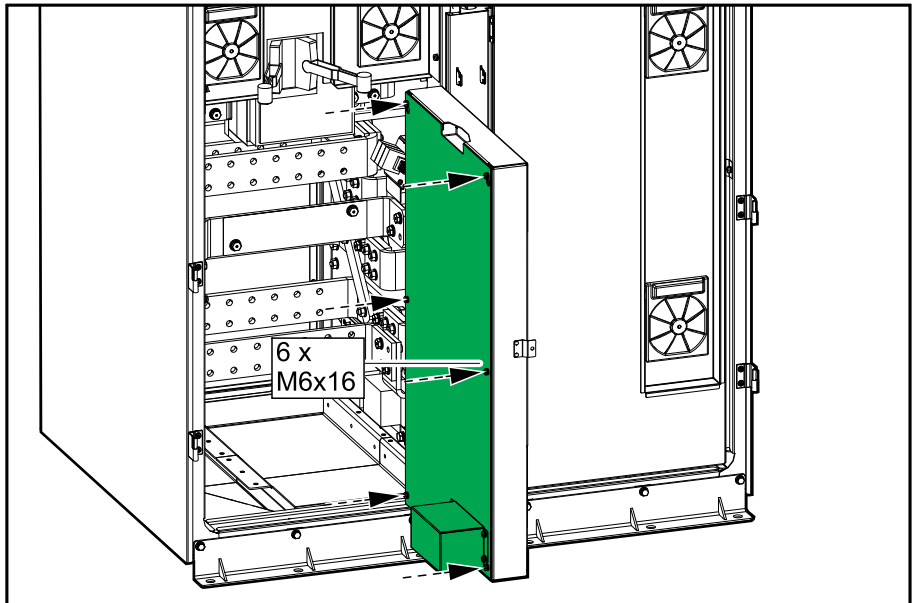

2. Close the door and fasten with the screw.

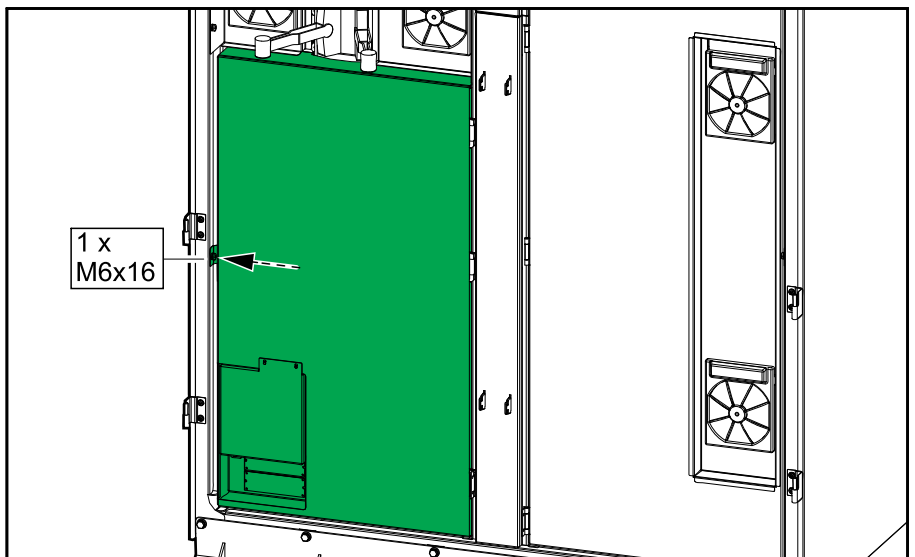

3. Reinstall the indicated cover if removed and fasten with the screws.

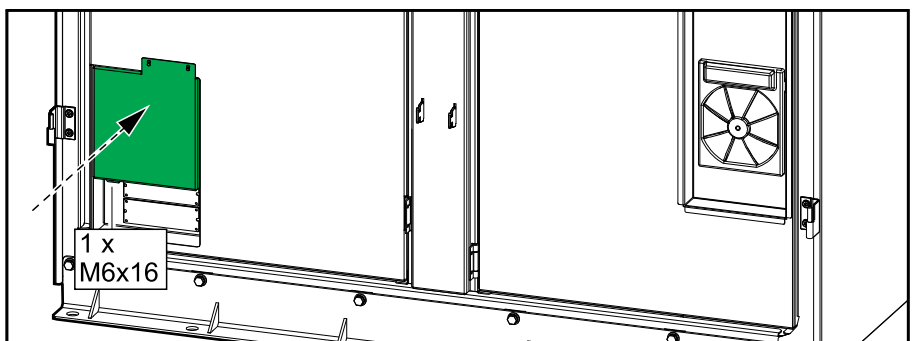

- Reinstall the cover on the door in the right side and fasten with the screws.

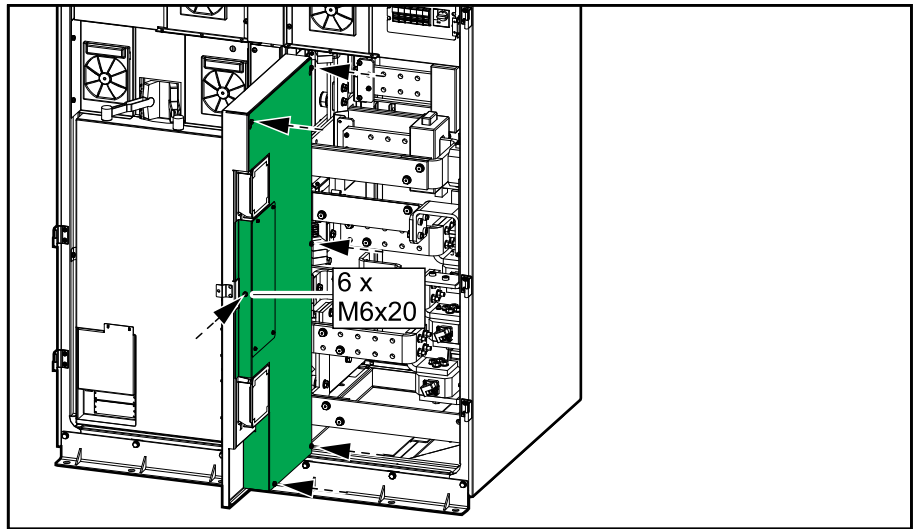

- Close the door and fasten with the screw.

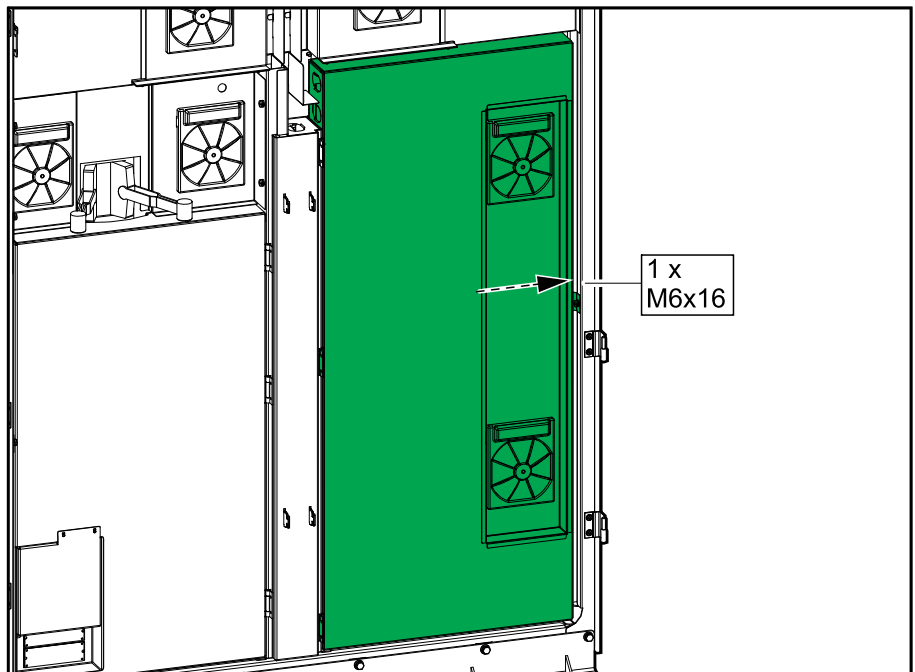

- Reinstall the two indicated covers and close the door in the top right corner. Fasten with screws.

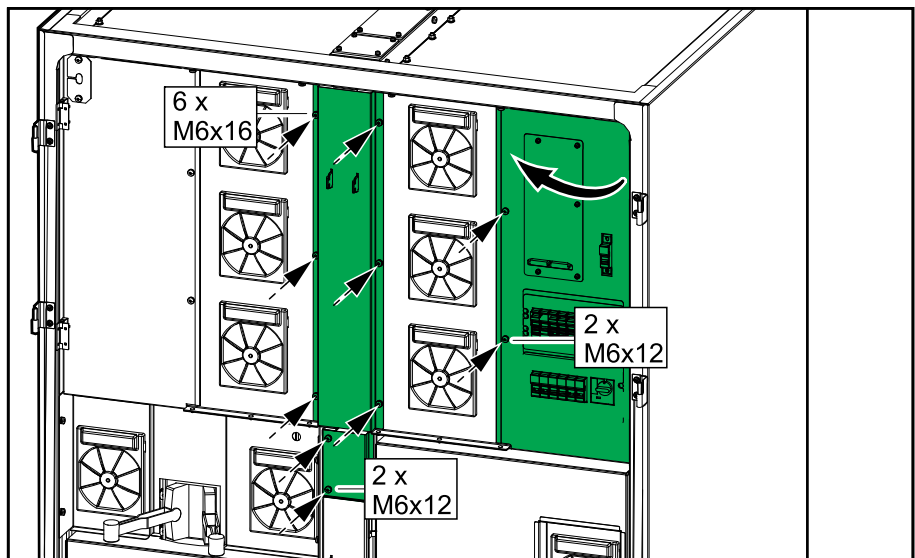

7. Close the front doors.

Final Mechanical Assembly of the Power Cabinets

NOTE: Perform the below steps on all the power cabinets.

1. Reinstall the three plates in the given order (a-c).

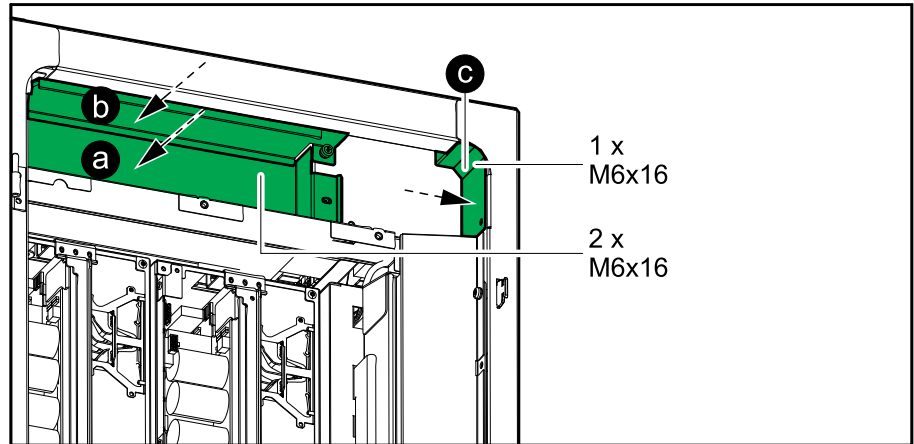

2. Reinstall the plate.

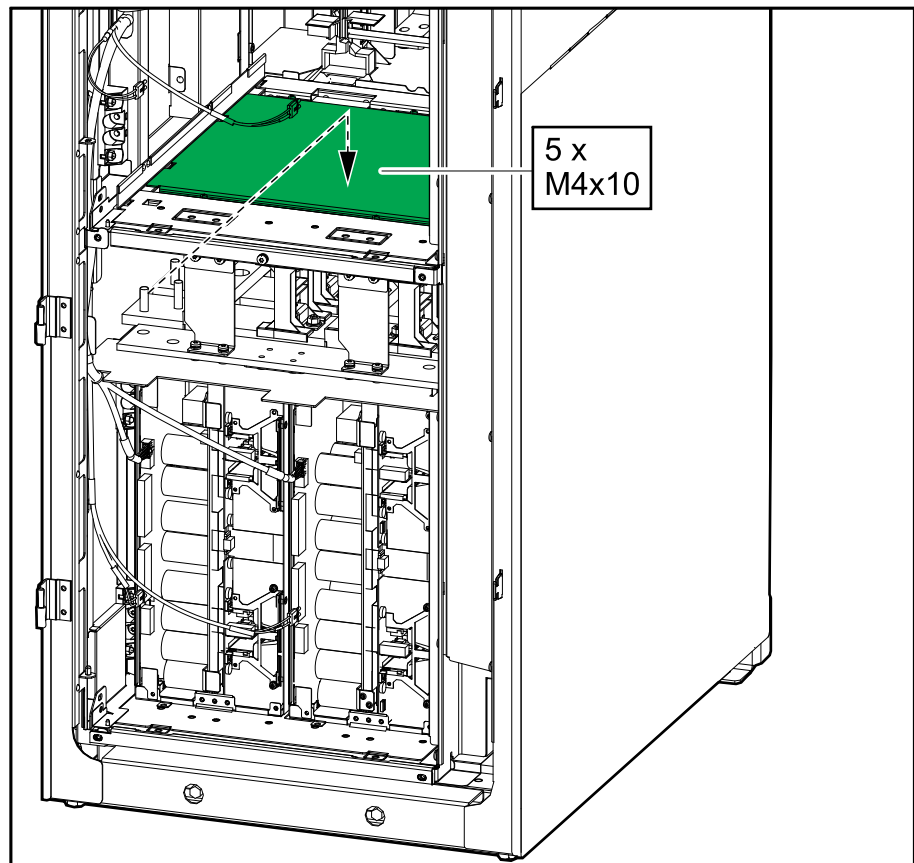

3. Push the two middle power blocks into the power cabinet and fasten.

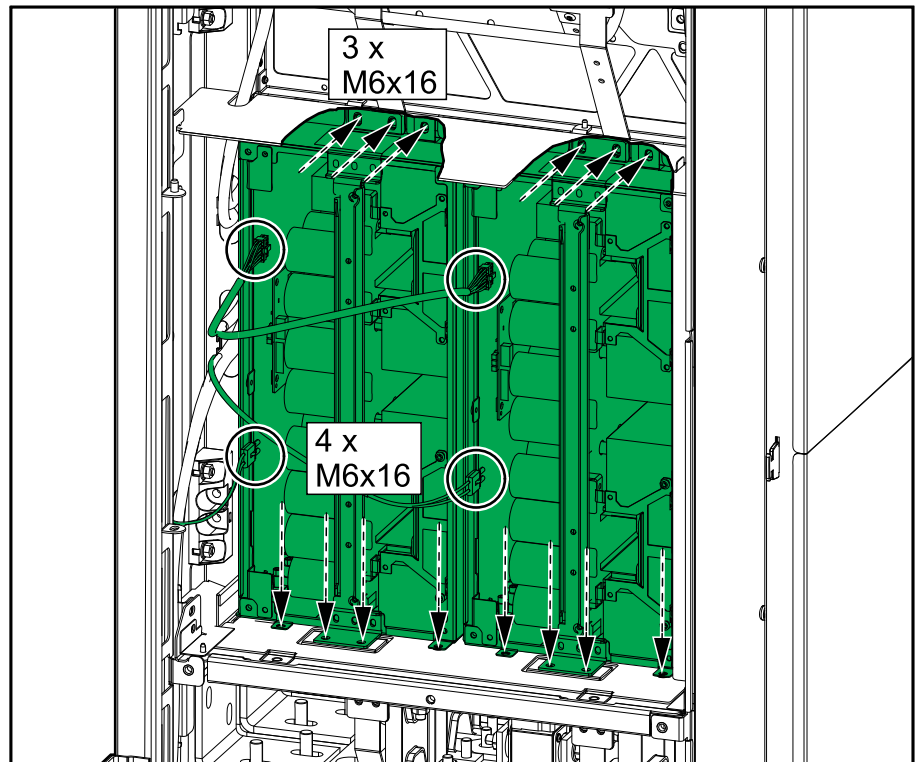

4. Reconnect the two cables to each of the two middle power blocks.
5. Reinstall the fan door and reconnect the cable to the fan door.

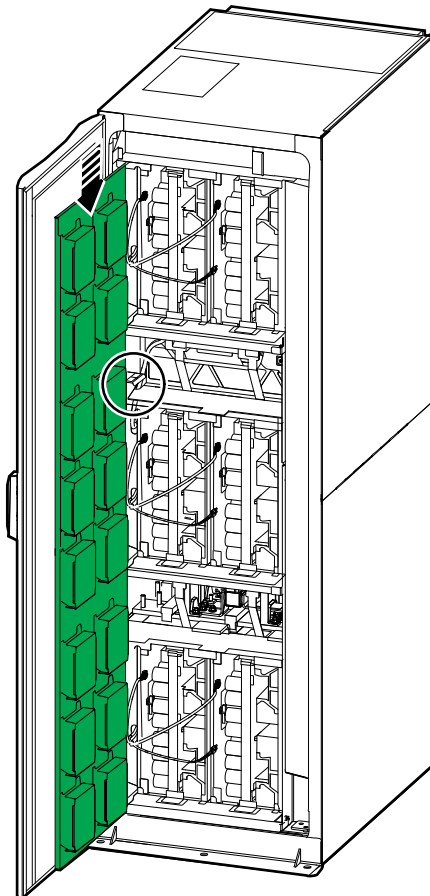

6. Close the fan door and fasten to the power cabinet.

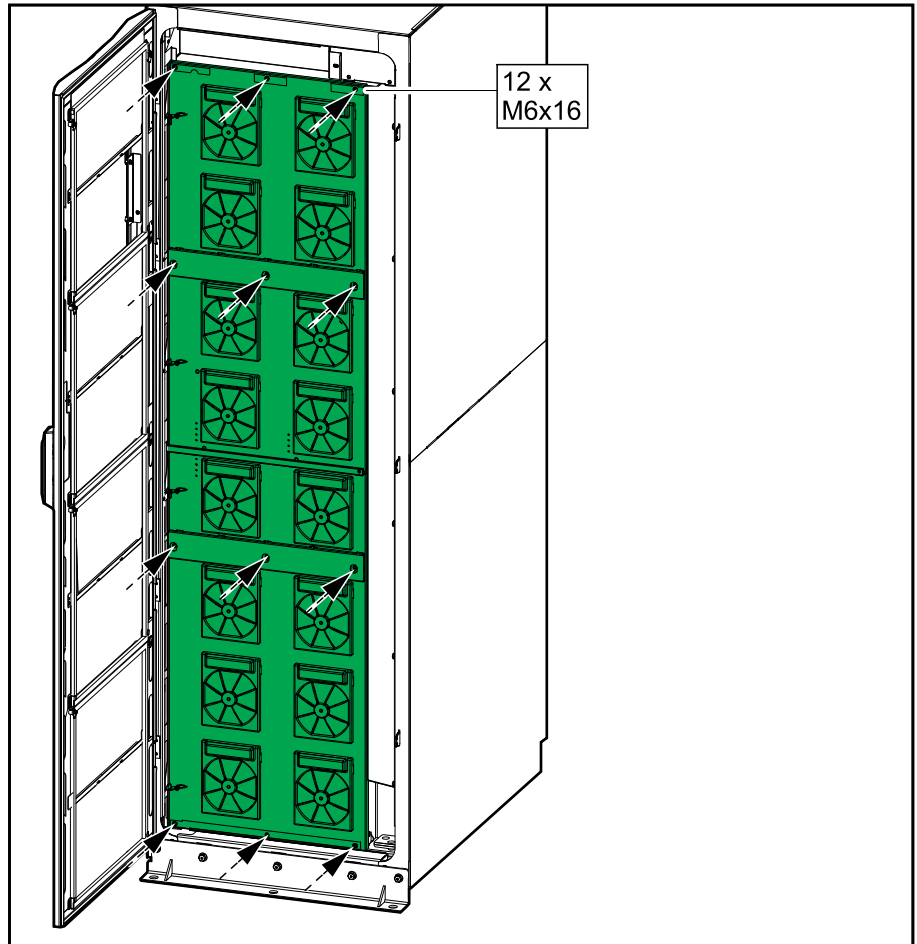

7. Close the front door.

Printed in:
Schneider Electric
35 rue Joseph Monier
92500 Rueil Malmaison - France
+ 33 (0) 1 41 29 70 00

Schneider Electric
35 rue Joseph Monier
92500 Rueil Malmaison
France

+ 33 (0) 1 41 29 70 00



As standards, specifications, and design change from time to time,
please ask for confirmation of the information given in this publication.

© 2020 – 2020 Schneider Electric. All rights reserved.

990-6264A-001