



- Loadmonitors - GAMMA series
- Digital setting
- Multifunction
- Temperature monitoring of the motor winding
- Fault latch
- Recognition of disconnected load
- Suitable for VFI (10 to 100Hz)
- Supply voltage selectable via power modules
- 2 change over contacts
- Width 45mm
- Industrial design



Technical data

1. Functions

True power monitoring for 1- or 3-phase loads with adjustable switching thresholds, adjustable start-up suppression time, separately adjustable tripping delay, selectable fault latch and temperature monitoring of the motor winding with max. 6 PTC.

OVER	Overload monitoring
OVER+I=0 ON	Overload monitoring and recognition of disconnected load (relay ON or OFF)
UNDER	Underload monitoring
UNDER+I=0 ON	Underload monitoring and recognition of disconnected load (relay ON or OFF)
2MIN	Minimum monitoring
2MIN+I=0 ON	Minimum monitoring and recognition of disconnected load (relay ON or OFF)
2MAX	Maximum monitoring
2MAX+I=0 ON	Maximum monitoring and recognition of disconnected load (relay ON or OFF)
WIN	Monitoring the window between MIN and MAX
WIN+I=0 ON	Monitoring the window between MIN and MAX and recognition of disconnected load (relay ON or OFF)
MAX/MIN	Maximum- and minimum monitoring
MAX/MIN+I=0 ON	Maximum- and minimum monitoring and recognition of disconnected load (relay ON or OFF)

2. Time ranges

	Adjustment range
Start-up suppression time (t2):	0s 100s
Tripping delay (Del_A / Del_B):	0,1s 50s

3. Indicators

Display specifications - see supplementary sheet

4. Mechanical design

Self-extinguishing plastic housing, IP rating IP40
 Mounted on DIN-Rail TS 35 according to EN 60715
 Mounting position: any
 Shockproof terminal connection according to VBG 4 (PZ1 required), IP rating IP20
 Tightening torque: max. 1Nm
 Terminal capacity:

- 1 x 0.5 to 2.5mm² with/without multicore cable end
- 1 x 4mm² without multicore cable end
- 2 x 0.5 to 1.5mm² with/without multicore cable end
- 2 x 2.5mm² flexible without multicore cable end

5. Input circuit

Supply voltage:
 24 to 240V AC/DC terminals A1-A2 (galvanically separated)
 Tolerance:
 24 to 240V DC -20% to +25%
 24 to 240V AC -15% to +10%
 Rated frequency:
 48 to 400Hz 24 to 240V AC
 16 to 48Hz 48 to 240V AC

Rated consumption: 2.8VA (1.6W)
 Duration of operation: 100%
 Reset time: 500ms
 Ripple and noise: -
 Drop-out voltage: >30% of the supply voltage
 Overvoltage category: III (in accordance with IEC 60664-1)
 Rated surge voltage: 4kV

6. Output circuit

2 potential free change over contacts
 Rated voltage: 250V AC
 Switching capacity: 750VA (3A / 250V AC)
 If the distance between the devices is less than 5mm!
 Rated voltage: 1250VA (5A / 250V AC)
 If the distance between the devices is greater than 5mm!
 Fusing: 5A fast acting
 Mechanical life: 20 x 10⁶ operations
 Electrical life: 2 x 10⁵ operations
 at 1000VA resistive load
 Switching capacity: max. 60/min at 100VA resistive load
 max. 6/min at 1000VA resistive load
 (in accordance with IEC 60947-5-1)
 Overvoltage category: III (in accordance with IEC 60664-1)
 Rated surge voltage: 4kV

7. Measuring circuit

Measuring range (Range): 2.5kW and 10kW
 Wave form
 AC Sinus: 10 to 400Hz
 Sinus weighted PWM: 10 to 100Hz
 Measuring input voltage: terminals L1-L2-L3
 1-phase loads 48 to 480V AC
 3-phase loads 3~ 48 to 480/277V
 Overload capacity:
 1-phase loads 550V AC
 3-phase loads 3~ 550/318V
 Input resistance: 1.25MΩ
 Measuring input current: terminals i-k
 Measuring range 2.5kW: 0.15 to 6A
 Measuring range 10kW: 0.3 to 12A
 (for I>8A distance >5mm)
 Overload capacity: 12A permanent
 Input resistance: <10mΩ
 Current transformer factor (Factor): 1-100
 Switching thresholds Th:
 Measuring range 2.5kW: 120W to 2490W
 Measuring range 10kW: 480W to 9960W
 Hysteresis: fixed 5% or adjustable
 Temperature monitoring θ:
 Terminals: T1-T2
 Initial resistance: <1.5kΩ
 Response value (Relais in on-position): ≥3.6kΩ
 Release value (Relais in off-position): ≤1.8kΩ
 Disconnection (short circuit thermistor): no
 Measuring voltage T1-T2: ≤7.5V at R ≤4.0kΩ
 (in accordance with EN 60947-8)

Technical data

Overvoltage category: III (in accordance with IEC 60664-1)
 Rated surge voltage: 4kV

Please note:

When the temperature monitoring isn't required the jumper must be set between the terminals T1-T2!

8. Control contact Y (equipotential with measuring circuit)

Function: Latch
 Terminals: Jumper Y1-Y2
 Loadable: no
 Line length Y1-Y2: max. 10m (twisted pair)
 Control pulse length: -
 Reset: normally closed contact in the input circuit
 normally closed contact in jumper Y1-Y2

9. Accuracy

Base accuracy: ±2% of upper range value
 Base accuracy leff: ±2% of upper range value
 Frequency response: ±0,025% / Hz
 Adjustment accuracy: -
 Repetition accuracy: ±2%
 Voltage influence: -
 Temperature influence: ≤0,02% / °C

10. Ambient conditions

Ambient temperature: -25 to +55°C (in accordance with IEC 60068-1)
 -25 to +40°C (in accordance with UL 508)
 Storage temperature: -25 to +70°C
 Transport temperature: -25 to +70°C
 Relative humidity: 15% to 85%
 (in accordance with IEC 60721-3-3 class 3K3)
 Pollution degree: 3 (in accordance with IEC 60664-1)
 Vibration resistance: 10 to 55Hz 0.35mm
 (in accordance with IEC 60068-2-6)
 Shock resistance: 15g 11ms
 (in accordance with IEC 60068-2-27)

Functions

When the supply voltage U is applied, the output relays Rel_1 and Rel_2 switches into on-position (state of output relay 11) and the set interval of the start-up suppression time (t2) begins. During this period, changes of the measured true power don't affect the state of the output relays Rel_1 and Rel_2 (state of output relay 11).

Overload monitoring (OVER)

The adjusted threshold Th_A must be greater than the adjusted threshold Th_B.

When the measured true power exceeds the adjusted threshold Th_A, the set interval of the tripping delay (Del_A) begins. After the interval has expired, the output relays Rel_1 and Rel_2 switches into off-position (state of output relay 00). As soon as the measured true power falls below the adjusted threshold Th_B, the set interval of on delay (Del_B) begins. After the interval has expired, the output relays Rel_1 and Rel_2 switches into on-position again (state of output relay 11).

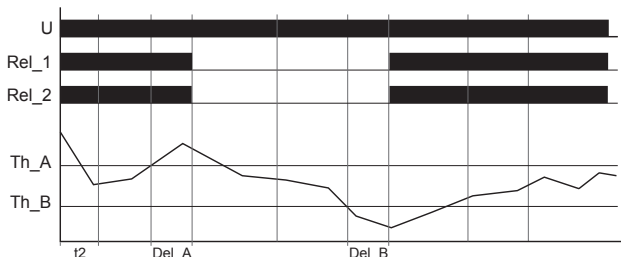

Underload monitoring (UNDER)

The adjusted threshold Th_A must be greater than the adjusted threshold Th_B.

When the measured true power falls below the adjusted threshold Th_B, the set interval of the tripping delay (Del_B) begins. After the interval has expired, the output relays Rel_1 and Rel_2 switches into off-position (state of output relay 00). As soon as the measured true power exceeds the adjusted threshold Th_A, the set interval of on delay (Del_A) begins. After the interval has expired, the output relays Rel_1 and Rel_2 switches into on-position again (state of output relay 11).

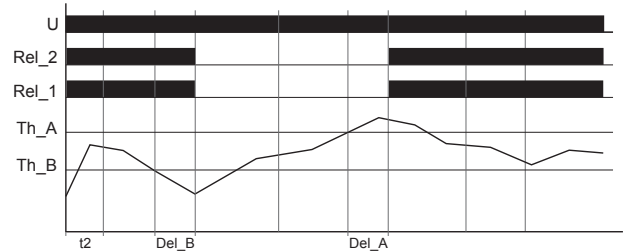

Minimum monitoring (2MIN)

The adjusted threshold Th_A must be greater than the adjusted threshold Th_B. When the measured true power falls below the adjusted threshold Th_B, the set interval of the tripping delay (Del_A) begins. After the interval has expired, the output relay Rel_1 switches into off-position (state of output relay 01). When the measured true power falls below the adjusted threshold Th_B, the set interval of the tripping delay (Del_B) begins. After the interval has expired, the output relay Rel_2 switches into off-position (state of output relay 00).

As soon as the measured true power exceeds the corresponding threshold (Th_A or Th_B), the output relays Rel_1 or Rel_2 switches into on-position again (state of output relay 11).

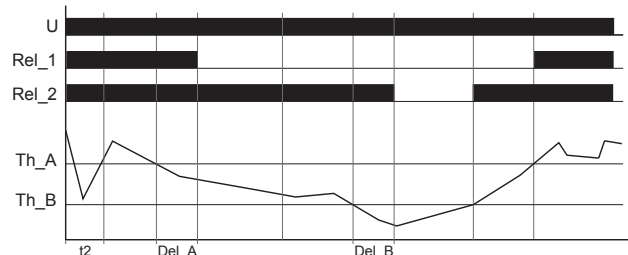

Window function (WIN)

The adjusted threshold Th_A must be greater than the adjusted threshold Th_B. When the measured true power falls below the adjusted threshold Th_B, the set interval of the tripping delay (Del_B) begins. After the interval has expired, the output relays Rel_1 and Rel_2 switches into off-position (state of output relay 00). As soon as the measured true power exceeds the adjusted threshold Th_B, the output relays Rel_1 and Rel_2 switches into on-position again (state of output relay 11). When the measured true power exceeds the adjusted threshold Th_A, the set interval of the tripping delay (Del_A) begins. After the interval has expired, the output relays Rel_1 and Rel_2 switches into off-position (state of output relay 00). As soon as the measured true power falls below the adjusted threshold Th_A, the output relays Rel_1 and Rel_2 switches into on-position again (state of output relay 11).

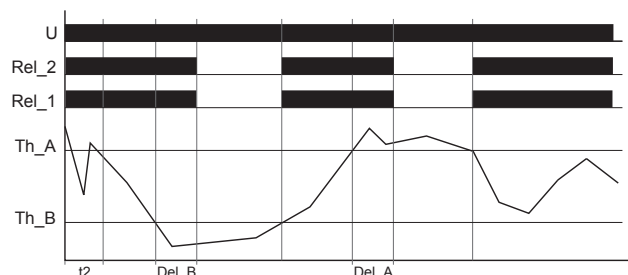

Functions

Maximum monitoring (2MAX)

The adjusted threshold Th_A must be greater than the adjusted threshold Th_B . When the measured true power exceeds the adjusted threshold Th_B , the set interval of the tripping delay (Del_B) begins. After the interval has expired, the output relay Rel_2 switches into off-position (state of output relay 10). When the measured true power exceeds the adjusted threshold Th_A , the set interval of the tripping delay (Del_A) begins. After the interval has expired, the output relay Rel_1 switches into off-position (state of output relay 00). As soon as the measured true power exceeds the corresponding threshold (Th_A or Th_B), the output relays Rel_1 or Rel_2 switches into on-position again (state of output relay 11).

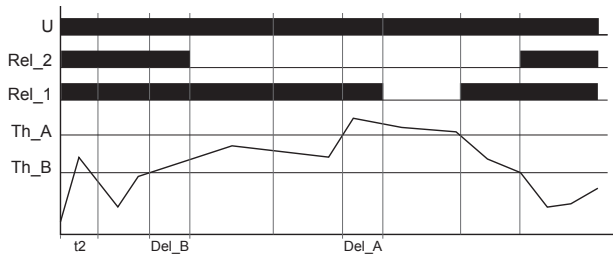

Maximum- and minimum monitoring (MIN/MAX)

The adjusted threshold Th_A must be greater than the adjusted threshold Th_B . When the measured true power exceeds the adjusted threshold Th_A , the set interval of the tripping delay (Del_A) begins. After the interval has expired, the output relay Rel_1 switches into off-position (state of output relay 01). As soon as the measured true power falls below the adjusted threshold Th_A , the output relay Rel_1 switches into on-position again (state of output relay 11). When the measured true power falls below the adjusted threshold Th_B , the set interval of the tripping delay (Del_B) begins. After the interval has expired, the output relay Rel_2 switches into off-position (state of output relay 10). As soon as the measured true power exceeds the adjusted threshold Th_B , the output relay Rel_2 switches into on-position again (state of output relay 11).

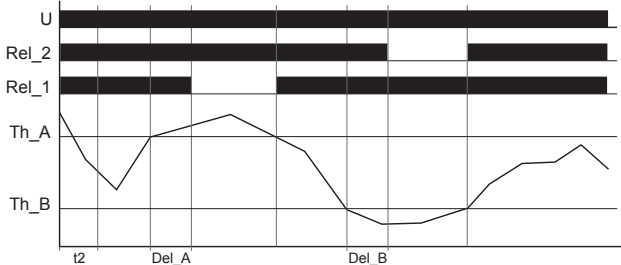

Fault latch

The fault latch can be activated via a jumper between the terminals Y1 and Y2 or via the display (Latch on).

If the fault latch is activated and a failure has occurred, the failure can be reset by activating the normal closed contact (Y1-Y2) or by pressing the plus- and minus-key (+ & -). After resetting the failure, the output relays Rel_1 and Rel_2 take their position according to the selected function and measured true power.

The device will be reset by interrupting the supply voltage. After reconnecting the supply voltage the output relays Rel_1 and Rel_2 switches into on-position and a new measuring cycle begins with the set interval of the start-up suppression time (t_2).

Please note:

The fault latch remains active in spite of a I=0 recognition!

Example: Window function (WIN) - Resetting the fault latch by activating the normal closed contact (Y1-Y2)

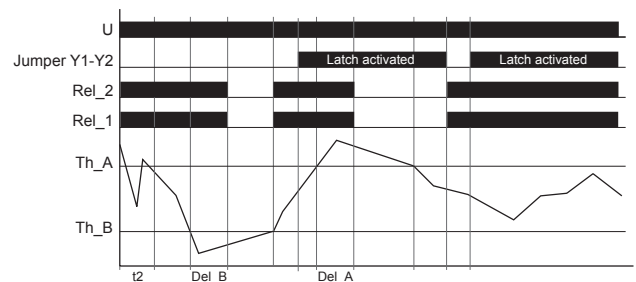

Example: Window function (WIN) - Resetting the fault latch by pressing the plus- and minus-key (+ & -)

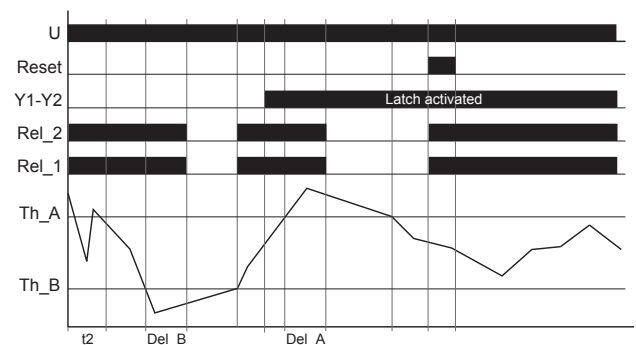

Temperature monitoring of the motor winding 9

If the supply voltage U is applied and the cumulative resistance of the PTC-circuit is less than $3.6k\Omega$ (standard temperature of the motor), the output relay Rel_2 switches into on-position if no other failure is applied! When the cumulative resistance of the PTC-circuit exceeds $3.6k\Omega$ (at least one of the PTCs has reached the cut-off temperature), the output relay Rel_2 switches into off-position and a temperature failure 9 will be indicated. The output relay Rel_2 switches into on-position again respectively the temperature failure 9 will be cancelled, if the cumulative resistance drops below $1.8k\Omega$ by cooling down of the PTC. If the fault latch is activated, the failure can be reset by activating the normal closed contact (Y1-Y2) or by pressing the plus- and minus-key (+ & -).

Please note:

If the output relay Rel_2 should switch into on-position again, no other failure should be applied!

When the temperature monitoring isn't required then the jumper must be set between the terminals T1-T2!

Functions

Temperature monitoring without fault latch

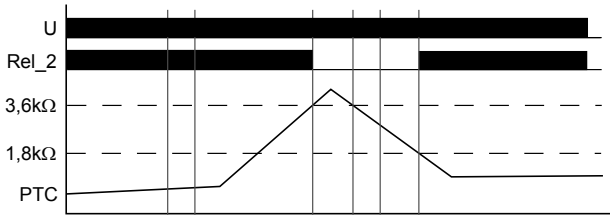

Temperature monitoring with fault latch

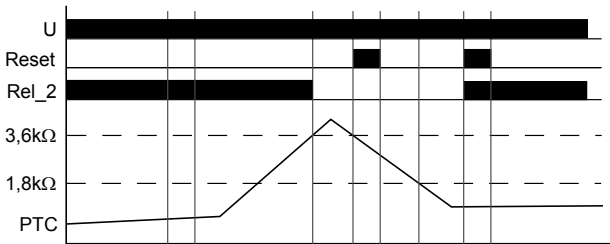

Recognition of disconnected load (I=0)

When the recognition of disconnected load (I=0) is activated, the relay state can be freely selected depending on the function.

When the current flow between i and k is interrupted, the output relays Rel_1 and Rel_2 remains into user-defined state.
When the current flow restores, the measuring cycle is restarted with the adjusted set interval of the start-up suppression time (t2).

Example: I=0 with minimum monitoring (2MIN+I=0 ON)
relay state normal: Rel_1 and Rel_2 on

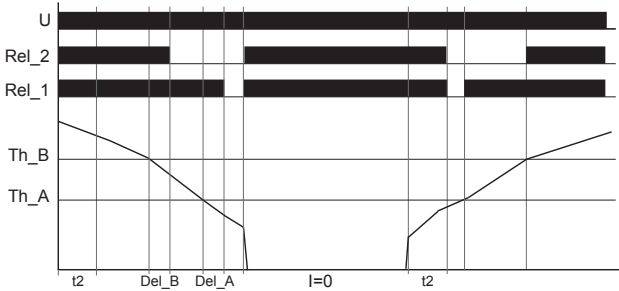

Example: I=0 Inv. with minimum monitoring (2MIN+I=0 ON)
relay state invers: Rel_1 and Rel_2 off

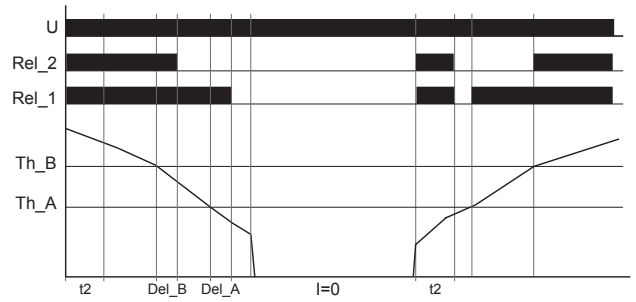

Example: I=0 with maximum monitoring (2MAX+I=0 ON)
relay state normal: Rel_1 and Rel_2 off

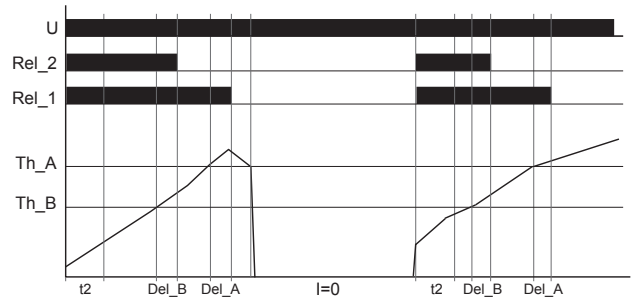

Example: I=0 Inv. with maximum monitoring (2MAX+I=0 ON)
relay state invers: Rel_1 and Rel_2 on

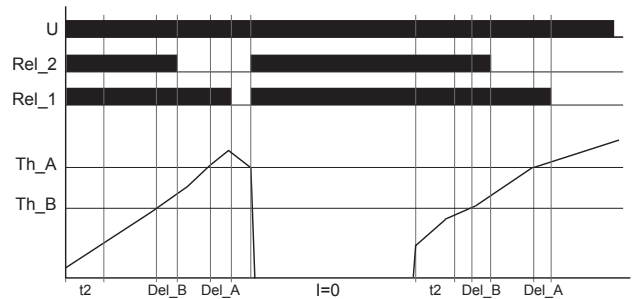

Connections

Connected 3~ without fault latch $I_N < 12A$

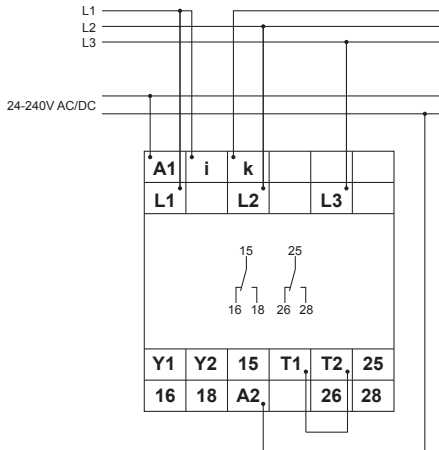

Connected 1~ without fault latch but with current transformer $I_N > 12A$

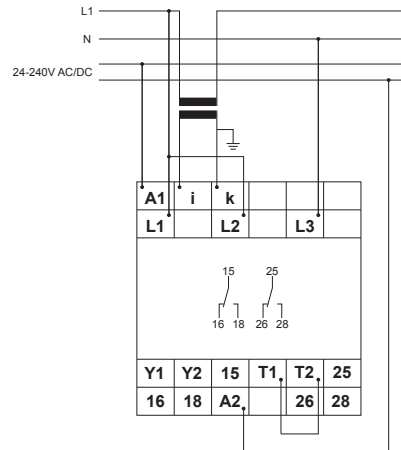

Connected 3~ with fault latch $I_N < 12A$

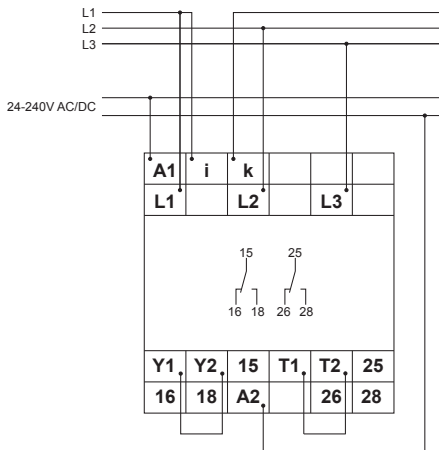

Connected 3~ with fault latch and current transformer $I_N > 12A$

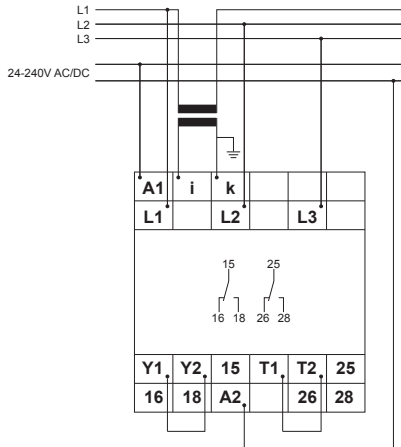

Connected 3~ with fault latch and temperature monitoring sensor $I_N < 12A$

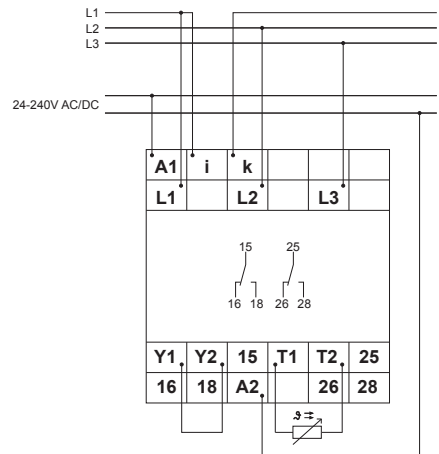

Dimensions

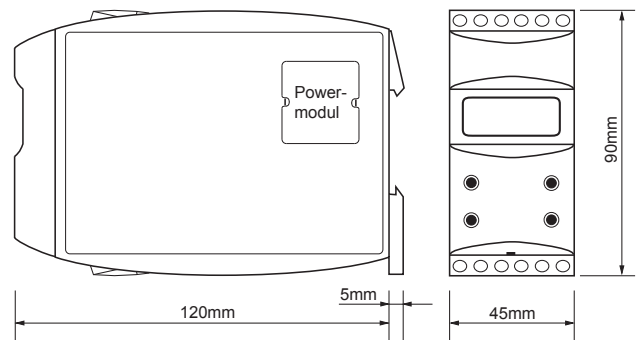

RELEASE 2010/08

Subject to alterations and errors

True power monitoring relay – G4BM480V12ADTL20

GAMMA Display Module

Content

1	General	2
1.1	Measured value display	2
1.2	Parameters	3
1.3	Menu configuration	5

1 General

The G4BM480V12ADTL20 is a digital module with a display. The digital module can be programmed via the keys (Esc / Ent / + / -). The measured values will be indicated on the alphanumeric display.

1.1 Measured value display

Indication measured variable:

P			ϑ	I	1	0
3	8	7	,	5	W	

P ... power

ϑ ... thermistor failure

Please note:

When the temperature monitoring isn't required the jumper must be set between the terminals T1-T2!

Indication measured variable:

I			ϑ	I	1	0
		8	,	0	A	

I ... current

ϑ ... thermistor failure

Please note:

When the temperature monitoring isn't required the jumper must be set between the terminals T1-T2!

Indication function:

F	u	n	c			
w	i	n	d	o	w	

Indication of current function (Func):

- Over Overload monitoring
 - Under Underload monitoring
 - Window Monitoring the window between MIN and MAX
 - 2MIN Minimum monitoring
 - 2MAX Maximum monitoring
 - MAX/MIN Maximum- and minimum monitoring
-

1.2 Parameters

Normally, the display only indicates the programmed parameters. When the device switches into the programming mode the letter “P” appears on the last position in the first line.

Parameter Function:

F	u	n	c		P
w	i	n	d	o	w

Selected functions (Func):

- Over Overload monitoring
- Under Underload monitoring
- Window Monitoring the window between MIN and MAX
- 2MIN Minimum monitoring
- 2MAX Maximum monitoring
- MAX/MIN Maximum- and minimum monitoring

Parameter start-up suppression time:

t	2				P
		9	,	0	s

Indication start-up suppression time (t2): adjustable between 0s to 100s

Parameter current transformer factor:

F	a	c	t	o	r	P
			1			

Indication current transformer factor (Factor): adjustable between 1 to 100

Parameter measured variable:

R	a	n	g	e		P
1	0	,	0	0	k	W

Indication measuring range (Range): reversible between 2.5kW and 10kW

Parameter threshold A:

T	h	_	A			P
4	5	0	,	0	W	

Indication threshold Th_A: adjustable between 120W to 9960W of measuring range (Range)

Parameter tripping delay for threshold A:

D	e	l	-	A		P
		5	,	0		s

Indication of tripping delay (Del_A) for threshold A: adjustable between 0.1s to 50s

Parameter threshold B:

T	h	-	B			P
3	2	0	,	0		W

Indication threshold Th_B: adjustable between 120W to 9960W of measuring range (Range)

Parameter tripping delay for threshold B:

D	e	l	-	B		P
		6	,	0		s

Indication of tripping delay (Del_B) for threshold B: adjustable between 0.1s to 50s

Parameter recognition of disconnected load (I=0):

I	=	0				P
o	f	f				

Activation (on) / Deactivation (off) recognition of disconnected load (I=0)

Parameter recognition of disconnected load (I=0) – arrangement of output relays

I	=	0	r	e	l	P
n	o	r	m	a	l	

Indication of relay outputs - normal or inverse if I=0 activated
(Recognition of disconnected load – relay on (1) or off (0))

Parameter fault latch (Latch):

L	a	t	c	h		P
o	f	f				

Fault latch (Latch): on or off

1.3 Menu configuration

