



GAS TILTING SKILLET 30 AND 40 GALLON

Job _____
Item# _____



GLTS-30

(show with option tangent draw-off)

Shall be a Crown model _____, gas fired tilting skillet, AGA/CGA and NSF Certified. The unit shall have a stainless steel cover with spring assist hinges, full width handle, no-drip condensate guide and vent port with swing cover. The pan shall have a sloped front and front hinged for easy tilting pour control and comes complete with a removable pour strainer. Pan is formed from 10 gauge type 304 stainless steel with a #4 finish exterior and polished interior with coved corners for ease of cleaning and etched gallon markings. Cooking surface shall be of 3/4" triple-ply construction with 3/8" thick aluminum core ensuring even heat distribution over entire cooking surface. The pan shall be mounted on a heavy duty welded frame with stainless steel exterior supported by an all welded 1-5/8" (41mm) stainless steel pipe frame with adjustable bullet feet and rear legs fitted with flange adjustable feet for securing to the floor.

The controls shall include a ON/OFF power switch, solid state thermostat with OFF position and range of 100-450°F (38-232°C), a thermostat indicator light, an ignition indicator light, pan tilt switch that shuts burners off if tilted more than 5°, and high temperature cut-off set at 536°F(280°C).

Tilting is controlled by an electric motor driven ball drive actuator for smooth and precise tilting action.

MODEL	CAPACITY		
	BTU	GALLON	LITER
GLTS-30	80,000	30	114
GLTS-40	100,000	40	152

OPERATION SHALL BE BY:

- Natural Gas
- Propane Gas

The controls shall be equipped for operating on 115 VAC, 1 phase, 50/60 Hz, 4 Amps

OPTIONAL ITEMS AT EXTRA COST:

- 220 VAC, 1 phase, 50/60 Hz
- Etched liter markings (LMS-30, LMS-40)
- 2" draw off valve with strainer, side mounted (TVT-2BP)
- 3" draw off valve with strainer, side mounted (TVT-3BP)
- Correctional Package

ACCESSORIES:

- Pan carrier (PC-1)
- Steam pan insert (SPI-30, SPI-40)
- 12" Single pantry faucet with swing spout (SF-12)
- 12" Double pantry faucet with swing spout (DF-12)
- 3" Stainless steel faucet plumbing enclosure (3139-1)
- Single pantry rinse spray head with 68" hose (SP-RSH)
- Double pantry rinse spray head with 68" hose (DP-RSH)



Models: GLTS-30 GLTS-40

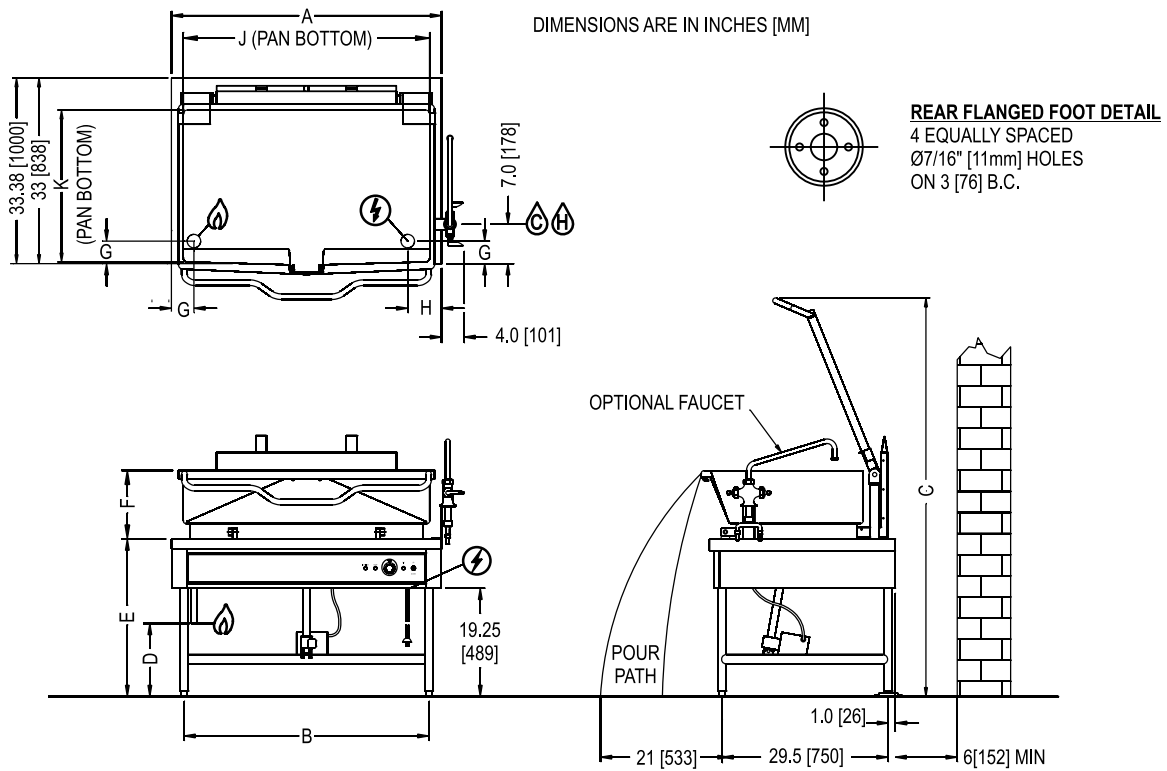

DIMENSIONS

MODEL	CAPACITY	UNITS	A	B	C	D	E	F	G	H	J	K
GLTS-30	30 Gallons (114 liters)	inches (millimeters)	36" (914 mm)	33.5" (851 mm)	70" (1800 mm)	13" (330 mm)	28" (711 mm)	12.25" (311 mm)	4" (102 mm)	6" (152 mm)	33.5" (851 mm)	23.5" (597 mm)
GLTS-40	40 Gallons (152 liters)	inches (millimeters)	48" (1219 mm)	45.5" (1156 mm)	70" (1800 mm)	13" (330 mm)	28" (711 mm)	12.25" (311 mm)	4" (102 mm)	6" (152 mm)	43.5" (1105 mm)	23" (584 mm)

MODEL	SHIPPING WEIGHT	GAS SUPPLY				MINIMUM CLEARANCE *	
		BTU/HR	KW/HR	Supply Pipe Pressure (W.C)			
GLTS-30	550 lbs. [249 kg]	80,000	23.4	Natural 6" - 14" (152 mm - 356 mm)	Propane 11" - 14" (279 mm - 356 mm)	Sides	3" (76 mm)
GLTS-40	736 lbs. [334 kg]	100,000	29.3			Back	6" (152 mm)

* For use on noncombustible floors only.

SERVICE CONNECTIONS

- ELECTRICAL CONNECTION: Unless otherwise specified, Field Wire Electrical Connection to be 120 Volts, 60 Hz, single phase with grounding wire. Unit furnished with 3 prong plug and 6' cord. Total max amps 4 Amps.
- GAS CONNECTION: Supply gas through 3/4" pipe.
- COLD WATER: 3/8" O.D. tubing to optional faucet
- HOT WATER: 3/8" O.D. tubing to optional faucet

**INTENDED FOR COMMERCIAL USE ONLY.
NOT FOR HOUSEHOLD USE.**



70 Oakdale Road, Toronto ON, Canada M3N 1V9
(919) 762-1000 www.crownsteamgroup.com