



Stainless design.
Stellar performance.
Superior value.



Arctic Air® Refrigeration Products 2019 Catalog

including Specifications and Dimensional Line Drawings



Introduction

TO OUR ARCTIC AIR® CUSTOMERS

For over 20 years Arctic Air has been a trusted brand in the U. S. commercial refrigeration market. We have strived year after year to provide a quality product at economical prices to our customers. In addition, as a family owned American company, it is our priority to maintain the high standard of customer service and support to our customers that they deserve and have come to expect. Finally, at Arctic Air it is our ongoing goal to maintain our respected standing in the commercial refrigeration industry by continuing to focus on product quality improvements while adding newly developed product offerings and continuing to grow with our customers.

Thank you again for your continued support.

Sincerely,

Walt Broich, Jr
President

WARRANTY SERVICE

If warranty service is required, please contact our warranty line directly at 1-855-431-5558. Information required at time of call is model, serial number, and batch number from sticker inside or on back of the unit. Also required will be name, address, contact info, and description of problem. Arctic Air Warranty Department will take all information and will get a local service agent dispatched as soon as possible. For complete warranty information see warranty page on back.

ARCTIC AIR RETURN POLICY

Arctic Air will only accept product returns on product that is in **original, unopened** package and was not shipped more than 30 days prior to return.

If product is in **original, unopened** carton, then we will accept returns to our MN warehouse. Returns are accepted with a 15% restocking fee. The outbound and return freight would be paid by party returning the product.

Credit will be given upon confirmation and inspection of returned products and they are determined to be in proper undamaged and unopened condition.



Product Index

| | |
|--|----|
| Single and Two Door Refrigerators and Freezers | 2 |
| Single Door Economy Refrigerators and Freezers..... | 4 |
| Single and Two Door Glass Reach-in Refrigerators | 6 |
| Refrigerated Counter-Top Prep Units | 8 |
| Compact Refrigerated Counter-Top Prep Units..... | 10 |
| Refrigerated Chef Bases | 12 |
| Undercounter/Worktop Refrigerators and Freezers | 14 |
| Pizza Prep Tables..... | 16 |
| Sandwich/Salad Prep Tables..... | 18 |
| Mega-Top Sandwich/Salad Prep Tables | 20 |
| Back Bar Refrigerators | 22 |
| Glass Door Back Bar Refrigerators | 24 |
| Direct Draw Beer Refrigerators..... | 26 |
| Horizontal Bottle Coolers..... | 28 |
| Terms and Conditions..... | 30 |





Single and Two Door Refrigerators and Freezers

- Electronic thermostat with external digital LED display for accurate control and easy reading.
- Interior cabinet is bright white aluminum liner with full stainless steel floor with coved corners.
- Three adjustable, heavy-duty epoxy coated wire shelves.
- Self-contained capillary tube system using environmentally friendly CFC free refrigerant.
- Exterior cabinet construction consists of full stainless steel front and sides.
- Condensate heating element built into condensate pan for efficient evaporation of excess water.
- Bottom mounted compressor for more efficient operation in coolest area of the kitchen.
- Front accessible, bottom mounted condensing unit is mounted on slide out rack for easy maintenance.
- Easy to mount casters (two lockable) are standard with all units.
- Self-closing doors that remain open at 90 degrees.
- Magnetic door gasket is removable and replaceable without tools.
- Field reversible, lockable door with foamed-in-place recessed handle.
- Larger fan motors and blades for more efficient air flow ensuring faster recovery times.



AR23
AF23



AR49
AF49

- **Optional Pan Slide Kit (#65100K)**
You can outfit half of the interior (full interior with two kits) with racks that hold eight standard sheet pans. Fits single door model only.
- **#64900K Sheet Pan Rack**
Free standing full height rack holds 14 full size sheet pans. Fits all s/s reach-in models.

- Tested to NSF Standard 7 requirements for open food storage.
- Full two year parts and labor warranty and a five year compressor warranty.



Approved models:
AR23
AR49
AF49

| Model Number | External Dimensions | | | Doors | Shelves | Cubic Feet | Temperature Range | Cord Length | HP | Amps | NEMA Plug | Crated Weight (lbs.) |
|--------------|---------------------|--------|--------|-------|---------|------------|-------------------|-------------|-----|------|-----------|----------------------|
| | Width | Depth | Height | | | | | | | | | |
| AR23 | 26.75" | 32.75" | 82.75" | 1 | 3 | 23 | 33°F to 41°F | 9' | 3/8 | 6 | 5-15P | 320 |
| AF23 | 26.75" | 32.75" | 82.75" | 1 | 3 | 23 | -11°F to -1°F | 9' | 5/8 | 11 | 5-15P | 335 |
| AR49 | 54" | 32.75" | 82.75" | 2 | 6 | 49 | 33°F to 41°F | 9' | 1/2 | 7 | 5-15P | 470 |
| AF49 | 54" | 32.75" | 82.75" | 2 | 6 | 49 | -11°F to -1°F | 9' | 1 | 12 | 5-15P | 500 |

PHONE 952-941-2270
FAX 952-941-3066
WEB www.arcticairco.com



DIMENSIONAL DRAWINGS

Specifications subject to change without notice.

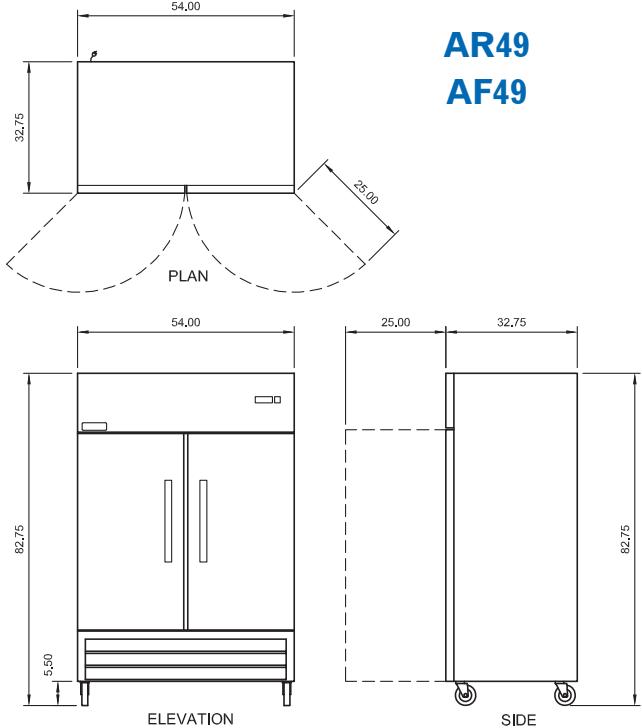
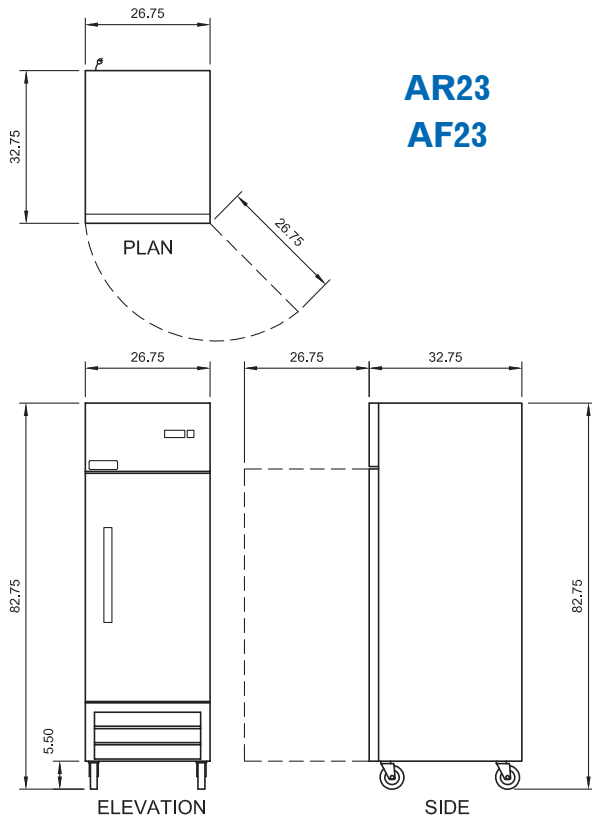

ARCTIC AIR® — A Division of Broich Enterprises, Inc. — An American Company since 1995





Single Door Economy Refrigerators and Freezers

- *Electronic thermostat with external digital LED display for accurate control and easy reading.*
- *Interior cabinet is bright white ABS liner.*
- *Three adjustable, heavy-duty epoxy coated wire shelves.*
- *Self-contained capillary tube system using environmentally friendly CFC free refrigerant.*
- *Exterior cabinet construction consists of white painted steel front and sides.*
- *Condensate heating element built into condensate pan for efficient evaporation of excess water.*
- *Bottom mounted compressor for more efficient operation in coolest area of the kitchen.*
- *Easy to mount casters (two lockable) are standard with all units.*
- *Magnetic door gasket is removable and replaceable without tools.*
- *Field reversible, lockable door with foamed-in-place recessed handle.*
- *Larger fan motors and blades for more efficient air flow ensuring faster recovery times.*
- *Tested to NSF Standard 7 requirements for open food storage.*
- *Full one year parts and labor warranty and a five year compressor warranty.*



**AWR25
AWF25**



**Approved model:
AWR25**

| Model Number | External Dimensions | | | Doors | Shelves | Cubic Feet | Temperature Range | Cord Length | HP | Amps | NEMA Plug | Crated Weight (lbs.) |
|--------------|---------------------|--------|--------|-------|---------|------------|-------------------|-------------|-----|------|-----------|----------------------|
| | Width | Depth | Height | | | | | | | | | |
| AWR25 | 30.75" | 29.00" | 78.00" | 1 | 3 | 25 | 33°F to 41°F | 9' | 1/4 | 4 | 5-15P | 310 |
| AWF25 | 30.75" | 29.00" | 78.00" | 1 | 3 | 25 | -11°F to -1°F | 9' | 3/4 | 7 | 5-15P | 325 |

PHONE 952-941-2270
FAX 952-941-3066
WEB www.arcticairco.com



DIMENSIONAL DRAWINGS

Specifications subject to change without notice.

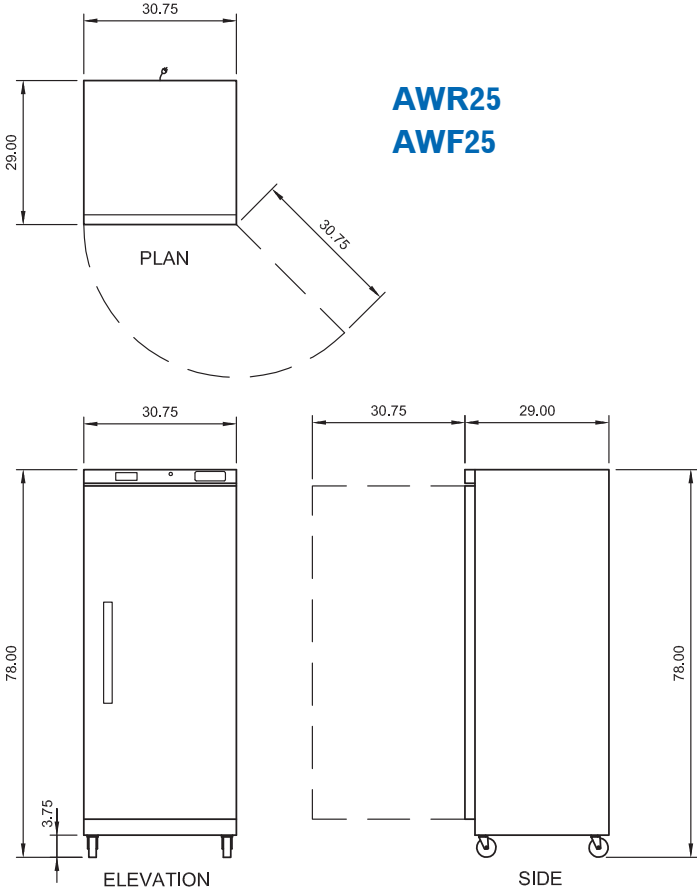

ARCTIC AIR® — A Division of Broich Enterprises, Inc. — An American Company since 1995





Single and Two Door Glass Reach-in Refrigerators

- *Electronic thermostat with external digital LED display for accurate control and easy reading.*
- *Interior cabinet is bright stainless liner with full stainless steel floor with coved corners.*
- *Three adjustable, heavy-duty epoxy coated wire shelves.*
- *Self-contained capillary tube system using environmentally friendly CFC free refrigerant.*
- *Exterior cabinet construction consists of full stainless steel front and sides.*
- *Condensate heating element built into condensate pan for efficient evaporation of excess water.*
- *Bottom mounted compressor for more efficient operation in coolest area of the kitchen.*
- *Front accessible, bottom mounted condensing unit is mounted on slide out rack for easy maintenance.*
- *Self-closing lockable doors.*
- *Magnetic door gasket is removable and replaceable without tools.*
- *Larger fan motors and blades for more efficient air flow ensuring faster recovery times.*
- *Easy to mount casters (two lockable) are standard with all units.*
- *Tested to NSF Standard 7 requirements for open food storage.*
- *Full two year parts and labor warranty and a five year compressor warranty.*



AGR23



AGR49

| Model Number | External Dimensions | | | Doors | Shelves | Cubic Feet | Temperature Range | Cord Length | HP | Amps | NEMA Plug | Crated Weight (lbs.) |
|--------------|---------------------|--------|--------|-------|---------|------------|-------------------|-------------|-----|------|-----------|----------------------|
| | Width | Depth | Height | | | | | | | | | |
| AGR23 | 27.0" | 31.25" | 83.25" | 1 | 3 | 23 | 33°F to 50°F | 8' | 1/3 | 6 | 5-15P | 330 |
| AGR49 | 54.0" | 31.25" | 83.25" | 2 | 6 | 49 | 33°F to 50°F | 6' | 1/2 | 8 | 5-15P | 500 |

PHONE 952-941-2270
FAX 952-941-3066
WEB www.arcticairco.com



DIMENSIONAL DRAWINGS

Specifications subject to change without notice.

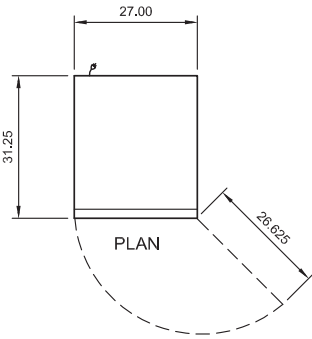

AGR23

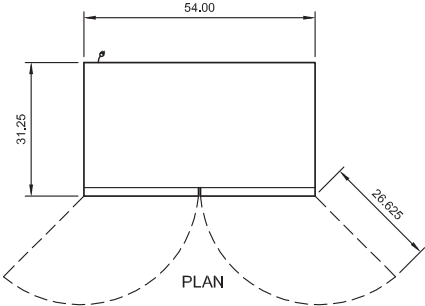

AGR49

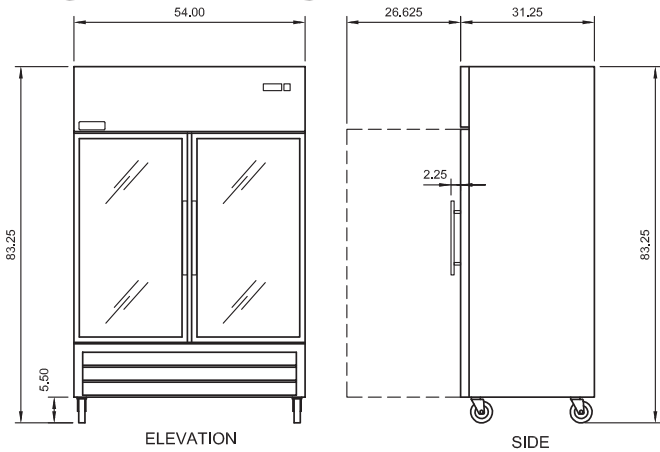
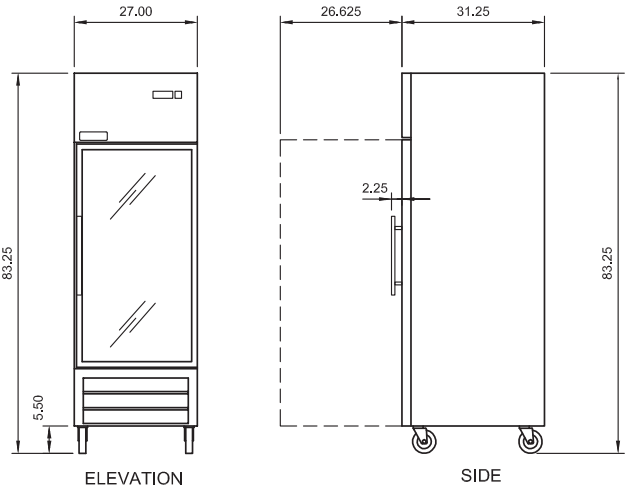

ARCTIC AIR® — A Division of Broich Enterprises, Inc. — An American Company since 1995



- Includes stainless cover for refrigerated area.
- Interior cabinet consists of full stainless steel liner.
- Exterior cabinet consists of full stainless steel shell.
- Plastic non-scratch feet included.
- Self-contained capillary tube system using environmentally friendly CFC free refrigerant (R290).
- Includes 1/6 size 6" deep stainless pans and covers.
- Stainless pan supports included.
- Electronic thermostat with external digital LED display for accurate control and easy reading.
- Tested to NSF Standard 7 requirements for open food storage.
- Full one year parts and labor warranty.
- *NOTE: No defrost systems. ACP is designated as an "in-service" item. Unit needs to be shut off to defrost.*



ACP48

ACP40



ACP55



ACP63

Optional:

Glass sneeze-guard available

- Part No. 65300K — ACP 55
- Part No. 65400K — ACP 48
- Part No. 65500K — ACP 63



| Model Number | External Dimensions | | | Temperature Range | Cord Length | Pans (1/6 Size) | Amps | NEMA Plug | Crated Weight (lbs.) |
|--------------|---------------------|--------|----------|-------------------|-------------|-----------------|------|-----------|----------------------|
| | Width | Depth* | Height** | | | | | | |
| ACP40 | 39.5" | 15.5" | 11" | 33°F to 41°F | 8' | 6 | 2 | 5-15P | 90 |
| ACP48 | 47.25" | 15.5" | 11" | 33°F to 41°F | 8' | 8 | 2 | 5-15P | 100 |
| ACP55 | 55.0" | 15.5" | 11" | 33°F to 41°F | 8' | 10 | 2 | 5-15P | 105 |
| ACP63 | 63.0" | 15.5" | 11" | 33°F to 41°F | 8' | 14 | 2 | 5-15P | 125 |

DIMENSIONAL DRAWINGS

Specifications subject to change without notice.

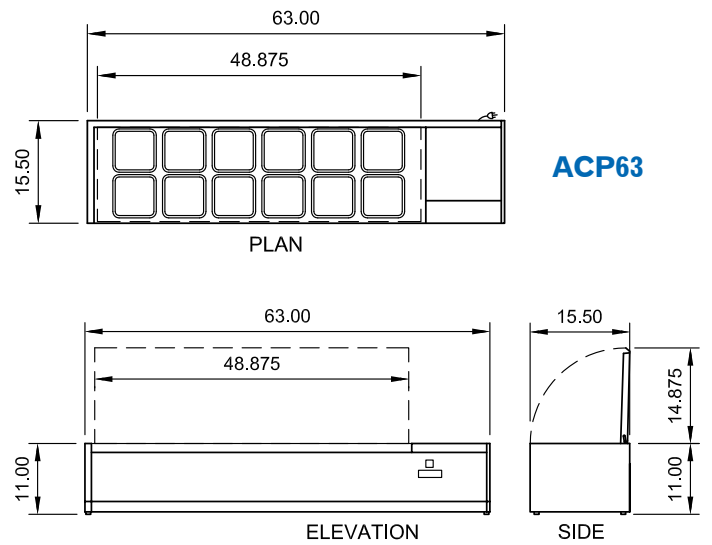
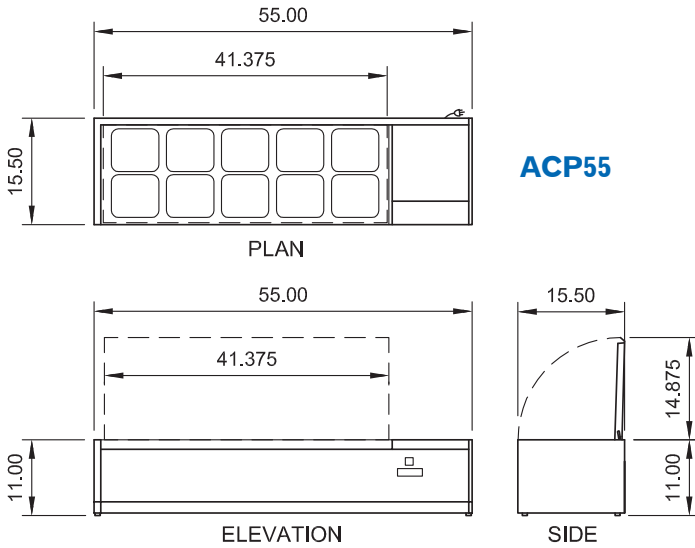
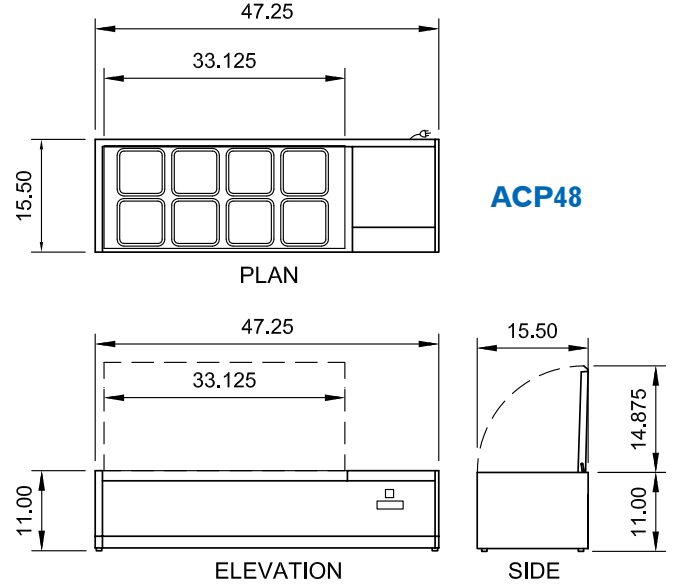
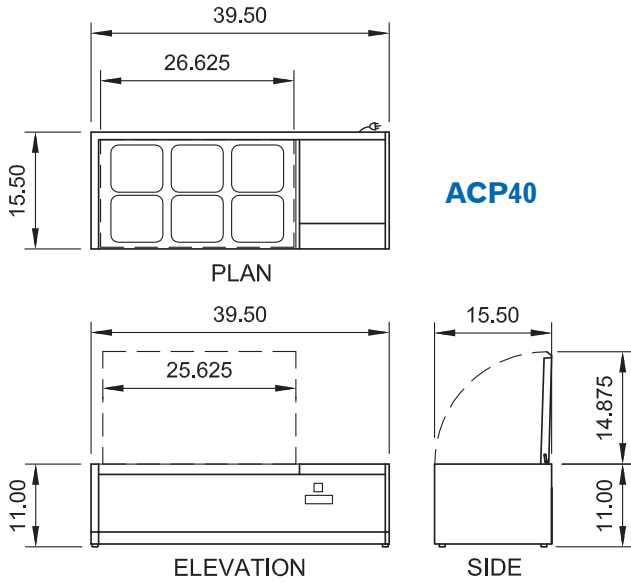

ARCTIC AIR® — A Division of Broich Enterprises, Inc. — An American Company since 1995





Compact Refrigerated Counter-Top Prep Units

- Interior cabinet consists of full stainless steel liner.
- Exterior cabinet consists of full stainless steel shell.
- Plastic non-scratch feet included.
- Includes 1/6 size pans and covers. 6" deep back row. 4 deep front row.
- Self-contained capillary tube system using environmentally friendly CFC free refrigerant.
- Tested to NSF Standard 7 requirements for open food storage.
- Full one year parts and labor warranty.
- **NOTE:** No defrost systems. ACP is designated as an "in-service" item. Unit needs to be shut off to defrost.



ACP4SQ



ACP8SQ

| Model Number | External Dimensions | | | Temperature Range | Cord Length | Pans (1/6 Size) | Pan Depth | Amps | NEMA Plug | Crated Weight (lbs.) |
|---------------|---------------------|--------|--------|-------------------|-------------|-----------------|---------------------|------|-----------|----------------------|
| | Width | Depth | Height | | | | | | | |
| ACP4SQ | 15.0" | 25.75" | 9.125" | 33°F to 41°F | 8' | 4 | Front 4" Back 6" | 4 | 5-15P | 65 |
| ACP8SQ | 27.5" | 25.75" | 9.125" | 33°F to 41°F | 8' | 8 | Front 4" Back 6" | 4 | 5-15P | 80 |

PHONE 952-941-2270
FAX 952-941-3066
WEB www.arcticairco.com



DIMENSIONAL DRAWINGS

Specifications subject to change without notice.

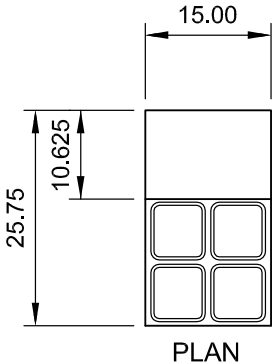

ACP4SQ

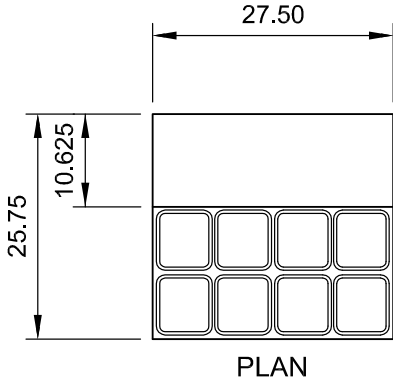
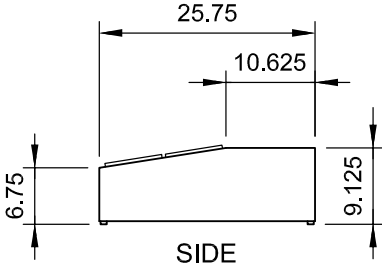
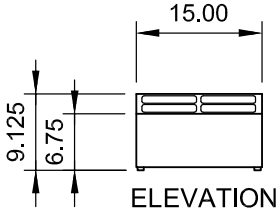

ACP8SQ

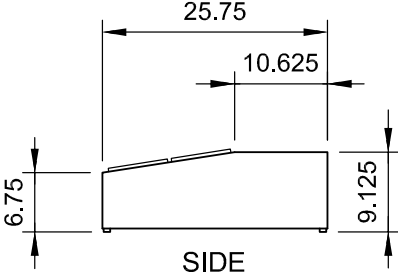
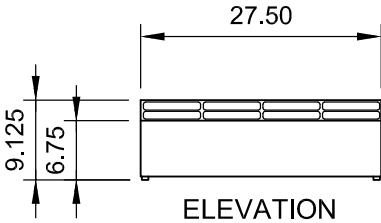

ARCTIC AIR® — A Division of Broich Enterprises, Inc. — An American Company since 1995



- Heavy duty stainless top is insulated with ceramic fabric layer to eliminate heat transfer to interior of cabinet.
- Top comes with standard marine edge on all sides and has a 1" extension on each side to allow cooking equipment to sit flat.
- Exterior cabinet construction consists of full stainless front, sides and top.
- Easy to mount casters (two lockable) are standard with all units.
- ARCB72 comes standard with (6) casters.
- Front breathing.
- Stainless steel drawer facings, linings and frames. Top drawer holds 4" deep pans and bottom drawer holds 6" deep pans.
- Each drawer is equipped with s/s hooked adaptor bars and magnetic gaskets that are removable for cleaning.
- Heavy duty Fulterer™ telescoping cartridge drawer system.
- Self-contained capillary tube system using environmentally friendly CFC free refrigerant (R290).
- Full extension drawers allow for loading and unloading of pans without tipping them.
- Electronic thermostat with external digital LED display for accurate control and easy reading.
- Front accessible condensing unit for easy cleaning and maintenance.
- Tested to NSF Standard 7 requirements for open food storage.
- Full two year parts, labor warranty and 5 year compressor warranty included.



Recommended Operating Conditions

- Installation of a heat shield is recommended for optimum performance (supplied by others).
- Counter top cooking equipment should be used in conjunction with the manufacturer supplied legs.
- Minimum clearance of 4" required between bottom of cooking equipment heating element and unit top. Failure to provide clearance voids manufacturer warranty.

| Model Number | External Dimensions | | | Drawers | Full Size Pan Capacity | Temperature Range | Cord Length | Amps | HP | NEMA Plug | Crated Weight (lbs.) |
|---------------|---------------------|-------|---------|---------|------------------------|-------------------|-------------|------|-----|-----------|----------------------|
| | Width | Depth | Height* | | | | | | | | |
| ARCB36 | 38.0" | 32.0" | 26.0" | 2 | 2** | 33°F to 41°F | 6' | 6 | 1/3 | 5-15P | 230 |
| ARCB48 | 50.0" | 32.0" | 26.0" | 2 | 4 | 33°F to 41°F | 6' | 6 | 1/3 | 5-15P | 250 |
| ARCB60 | 62.0" | 32.0" | 26.0" | 2 | 6 | 33°F to 41°F | 6' | 6 | 1/3 | 5-15P | 270 |
| ARCB72 | 74.0" | 32.0" | 26.0" | 4 | 6** | 33°F to 41°F | 6' | 6 | 1/3 | 5-15P | 355 |

*Height includes 5" for casters

** Additional 1/3 size pans will also fit in these models

PHONE 952-941-2270
FAX 952-941-3066
WEB www.arcticairco.com



DIMENSIONAL DRAWINGS

Specifications subject to change without notice.

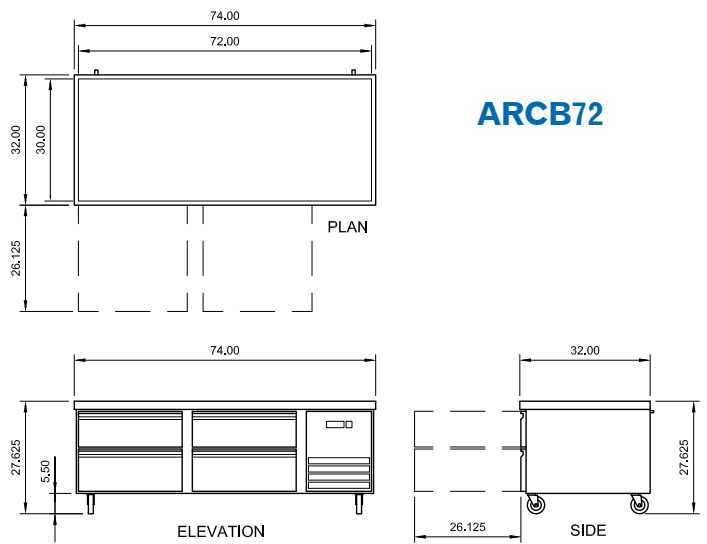
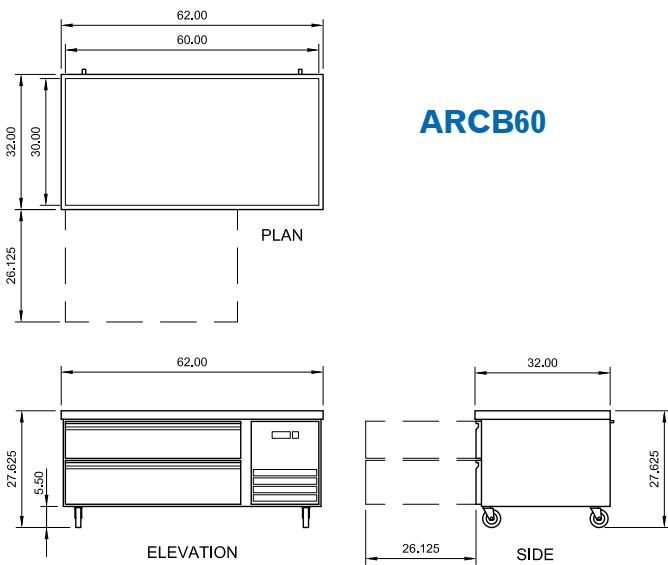
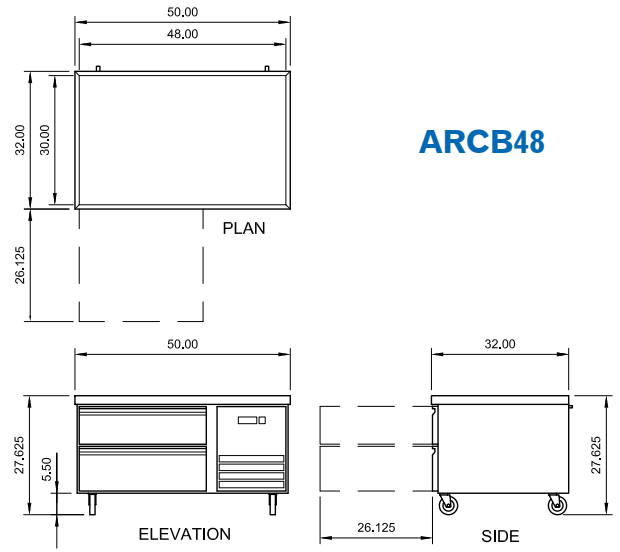
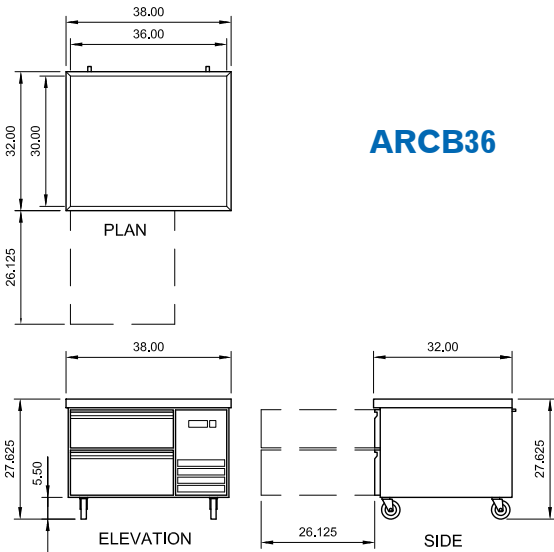

ARCTIC AIR® — A Division of Broich Enterprises, Inc. — An American Company since 1995





Undercounter/Worktop Refrigerators and Freezers

- All units come standard with heavy-duty worktop surface.
- Standard top panel is removable for use in lower height applications (reduces total height by 1.5").
- Exterior cabinet construction consists of full stainless steel front and sides.
- One/two adjustable, heavy-duty epoxy coated wire shelves.
- Interior cabinet is bright white ABS liner with full stainless steel floor white coved corners.
- Condensate heating element built into condensate pan for efficient evaporation of excess water.
- Electronic thermostat with external digital LED display for accurate control and easy reading
- Easy to mount casters (two lockable) are standard with all units.
- Self-closing doors that remain open at 90 degrees.
- Solid door construction with foamed-in-place recessed handle.
- Magnetic door gaskets are removable and replaceable without tools.
- Larger fan motors and blades for more efficient air flow ensuring faster recovery times.
- Self-contained capillary tube system using environmentally friendly CFC free refrigerant (R290).
- Tested to NSF Standard 7 requirements for open food storage.
- Full two year parts and labor warranty and a five year compressor warranty.



**AUC27R
AUC27F**



**AUC48R
AUC48F**



**Approved models:
AUC27R
AUC48R**

| Model Number | External Dimensions | | | Doors | Shelves | Cubic Feet | Temperature Range | Cord Length | HP | Amps | NEMA Plug | Crated Weight (lbs.) |
|---|---------------------|-------|---------|-------|---------|------------|-------------------|-------------|-----|------|-----------|----------------------|
| | Width | Depth | Height | | | | | | | | | |
| AUC27R | 27.875" | 30.0" | 35.625" | 1 | 1 | 6.5 | 33°F to 41°F | 8' | 3/8 | 5 | 5-15P | 185 |
| AUC27F | 27.875" | 30.0" | 35.625" | 1 | 1 | 6.5 | -11°F to -1°F | 8' | 1/2 | 7 | 5-15P | 190 |
| Height with worktop panel removed = 34.125" | | | | | | | | | | | | |
| AUC48R | 48.25" | 30.0" | 35.625" | 2 | 2 | 12 | 33°F to 41°F | 8' | 3/8 | 5 | 5-15P | 265 |
| AUC48F | 48.25" | 30.0" | 35.625" | 2 | 2 | 12 | -11°F to -1°F | 8' | 5/8 | 9 | 5-15P | 285 |
| Height with worktop panel removed = 34.125" | | | | | | | | | | | | |

PHONE 952-941-2270
FAX 952-941-3066
WEB www.arcticairco.com



DIMENSIONAL DRAWINGS

Specifications subject to change without notice.

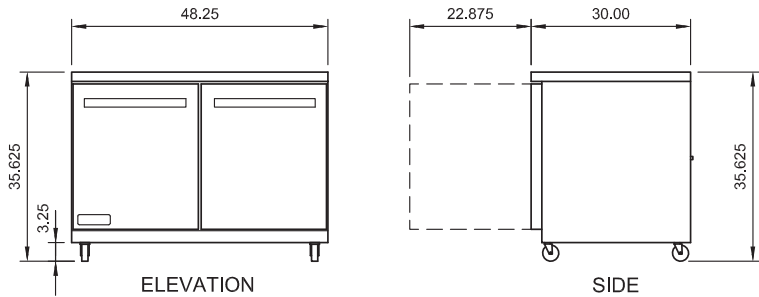
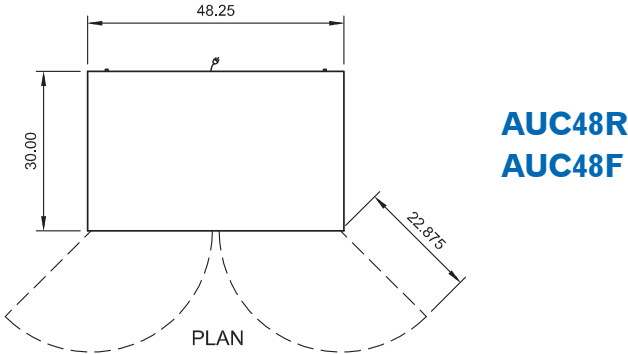
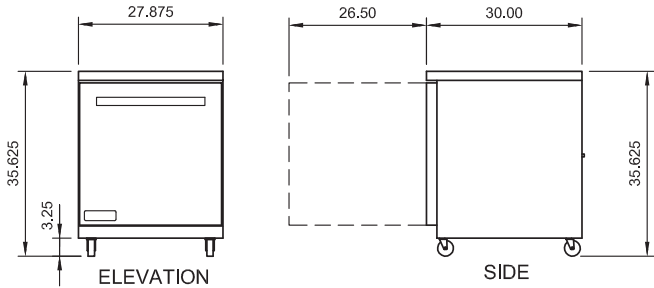
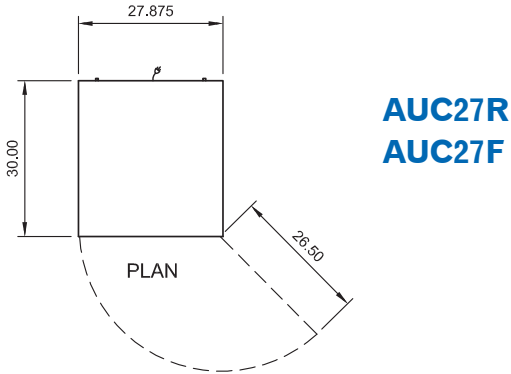

ARCTIC AIR® — A Division of Broich Enterprises, Inc. — An American Company since 1995



- 1/3 size plastic pans included.
- Full length, heavy-duty cutting board is included.
- Self-closing doors that remain open at 90 degrees.
- Solid door construction with foamed-in-place recessed handle.
- Exterior cabinet construction consists of full stainless steel front and sides.
- Interior cabinet is bright white ABS liner with full stainless steel floor with coved corners.
- Magnetic door gaskets are removable and replaceable without tools.
- Electronic thermostat with external digital LED display for accurate control and easy reading.
- Easy to mount casters (two locking) are standard with all units.
- Tested to NSF Standard 7 requirements for open food storage.
- Full two year parts and labor warranty and a five year compressor warranty.



APP48R



APP71R

| Model Number | External Dimensions | | | Doors | Shelves | Pans | Cubic Feet | Temperature Range | Cord Length | HP | Amps | NEMA Plug | Crated Weight (lbs.) |
|---------------|---|--------|--------|-------|---------|---------|------------|-------------------|-------------|-----|------|-----------|----------------------|
| | Width | Depth | Height | | | | | | | | | | |
| APP48R | 47.50" | 32.25" | 41.00" | 1 | 1 | 6 (1/3) | 12 | 33°F to 41°F | 8' | 1/2 | 7 | 5-15P | 310 |
| | Cutting board depth — 17.75" | | | | | | | | | | | | |
| | Total depth with cutting board — 35.25" | | | | | | | | | | | | |
| APP71R | 71.00" | 32.25" | 41.00" | 2 | 2 | 9 (1/3) | 21 | 33°F to 41°F | 8' | 1/2 | 7.5 | 5-15P | 410 |
| | Cutting board depth — 17.75" | | | | | | | | | | | | |
| | Total depth with cutting board — 35.25" | | | | | | | | | | | | |

PHONE 952-941-2270
FAX 952-941-3066
WEB www.arcticairco.com



DIMENSIONAL DRAWINGS

Specifications subject to change without notice.

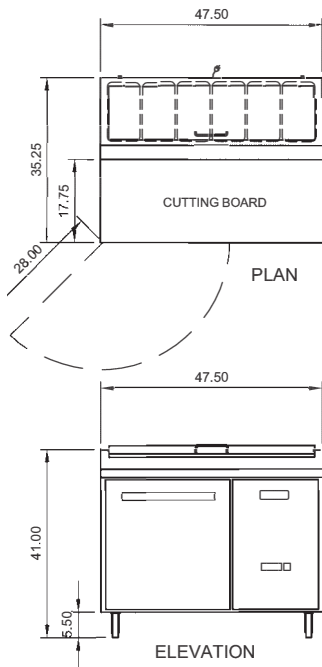

APP48R

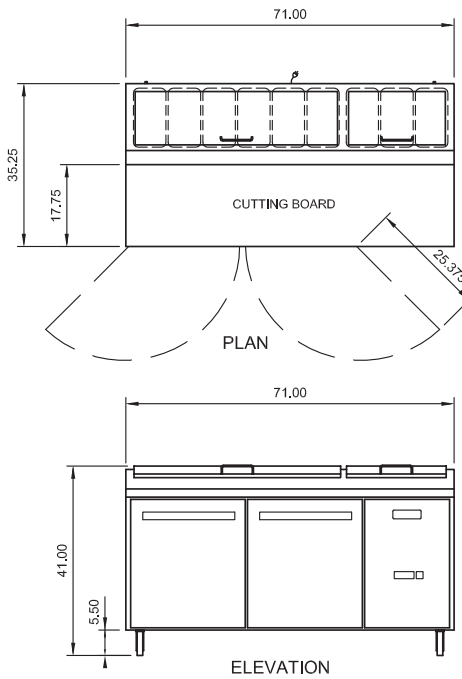
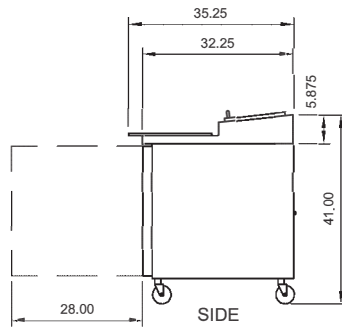

APP71R



ARCTIC AIR® — A Division of Broich Enterprises, Inc. — An American Company since 1995



- 1/6 size plastic pans included.
- Full length, heavy-duty cutting board is included.
- Self-closing doors that remain open at 90 degrees.
- Solid door construction with foamed-in-place recessed handle.
- Exterior cabinet construction consists of full stainless steel front and sides.
- Interior cabinet is bright white ABS liner with full stainless steel floor with coved corners.
- Magnetic door gaskets are removable and replaceable without tools.
- Electronic thermostat with external digital LED display for accurate control and easy reading.
- Easy to mount casters (two locking) are standard with all units.
- Tested to NSF Standard 7 requirements for open food storage.
- Full two year parts and labor warranty and a five year compressor warranty.



AST28R



AST48R



AST60R



AST72R

| Model Number | External Dimensions | | | Doors | Shelves | Pans | Cubic Feet | Temperature Range | Cord Length | HP | Amps | NEMA Plug | Crated Weight (lbs.) |
|---------------|---------------------|--------|--------|-------|---------|----------|------------|-------------------|-------------|-----|------|-----------|----------------------|
| | Width | Depth | Height | | | | | | | | | | |
| AST28R | 29.00" | 30.00" | 43.30" | 1 | 1 | 8 (1/6) | 6.5 | 33°F to 41°F | 8' | 3/8 | 5 | 5-15P | 215 |
| AST48R | 48.25" | 30.00" | 43.30" | 2 | 2 | 12 (1/6) | 12 | 33°F to 41°F | 8' | 1/2 | 7 | 5-15P | 300 |
| AST60R | 61.25" | 30.00" | 43.30" | 2 | 2 | 16 (1/6) | 15.5 | 33°F to 41°F | 8' | 1/2 | 7 | 5-15P | 385 |
| AST72R | 71.5" | 30.00" | 43.30" | 3 | 3 | 18 (1/6) | 18 | 33°F to 41°F | 8' | 1/2 | 7 | 5-15P | 425 |

PHONE 952-941-2270
FAX 952-941-3066
WEB www.arcticairco.com



DIMENSIONAL DRAWINGS

Specifications subject to change without notice.

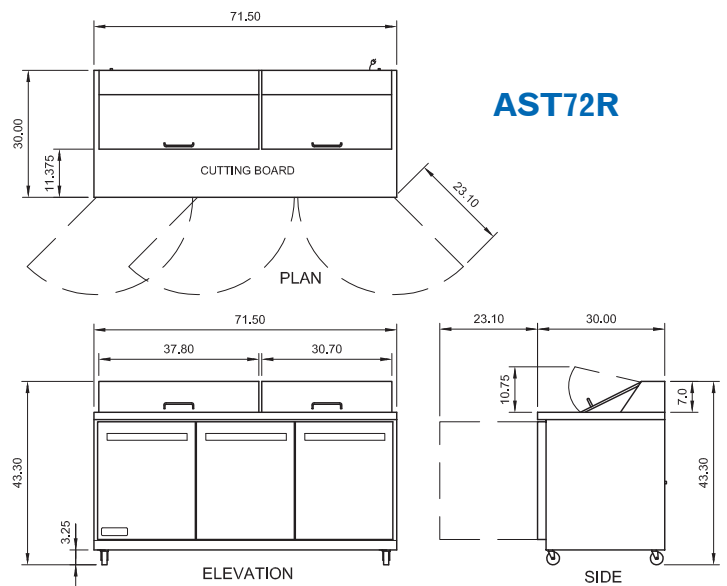
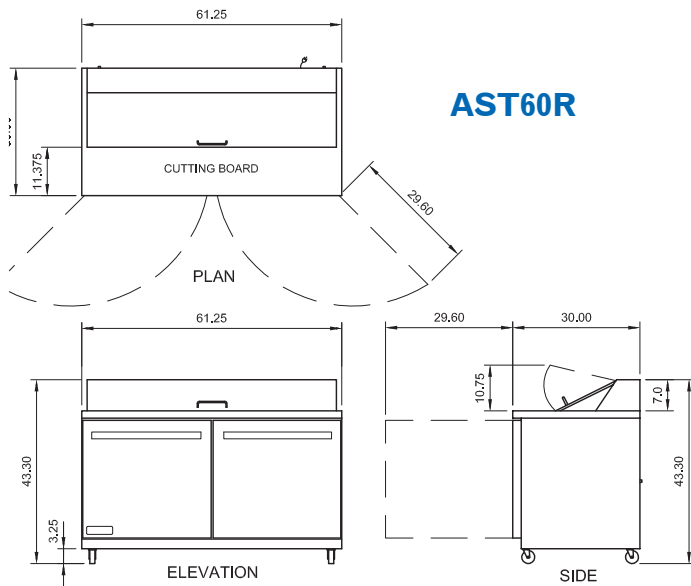
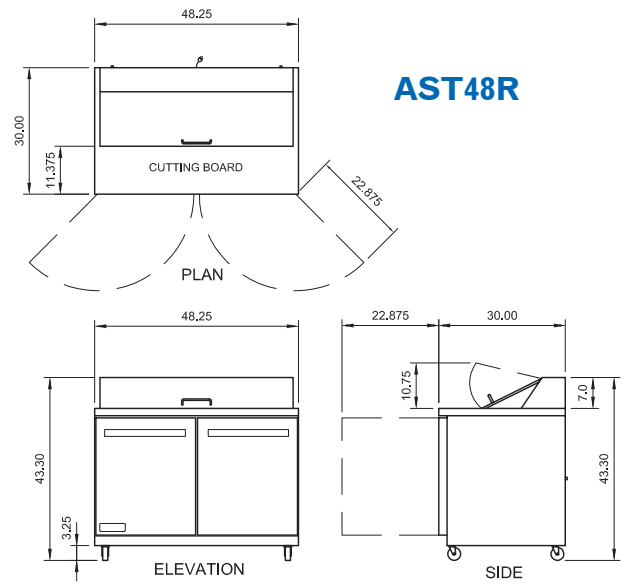
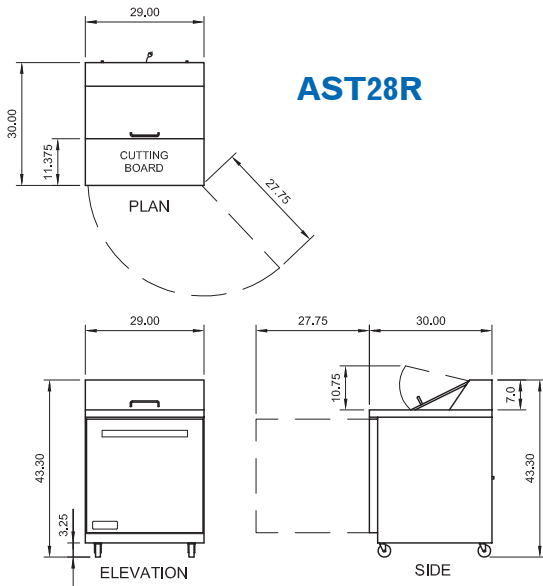

ARCTIC AIR® — A Division of Broich Enterprises, Inc. — An American Company since 1995



Mega-Top Sandwich/Salad Prep Tables

- Added space allows for extra rows of pans.
- 1/6 size plastic pans included.
- Full length, heavy-duty cutting board is included.
- Self-closing doors that remain open at 90 degrees.
- Solid door construction with foamed-in-place recessed handle.
- Exterior cabinet construction consists of full stainless steel front and sides.
- Interior cabinet is bright white ABS liner with full stainless steel floor with coved corners.
- Magnetic door gaskets are removable and replaceable without tools.
- Electronic thermostat with external digital LED display for accurate control and easy reading.
- Easy to mount casters (two locking) are standard with all units.
- Tested to NSF Standard 7 requirements for open food storage.
- Full two year parts and labor warranty and a five year compressor warranty.



AMT28R



AMT48R



AMT60R

| Model Number | External Dimensions | | | Doors | Shelves | Pans | Cubic Feet | Temperature Range | Cord Length | HP | Amps | NEMA Plug | Crated Weight (lbs.) |
|---------------|----------------------------|--------|--------|-------|---------|----------|------------|-------------------|-------------|-----|------|-----------|----------------------|
| | Width | Depth | Height | | | | | | | | | | |
| AMT28R | 29.00" | 34.50" | 43.30" | 1 | 1 | 12 (1/6) | 6.5 | 33°F to 41°F | 8' | 3/8 | 5 | 5-15P | 230 |
| | Cutting board depth — 9.0" | | | | | | | | | | | | |
| AMT48R | 48.25" | 34.50" | 43.30" | 2 | 2 | 18 (1/6) | 12 | 33°F to 41°F | 8' | 1/2 | 7 | 5-15P | 320 |
| | Cutting board depth — 9.0" | | | | | | | | | | | | |
| AMT60R | 61.25" | 34.50" | 43.30" | 2 | 2 | 24 (1/6) | 15.5 | 33°F to 41°F | 8' | 1/2 | 7.5 | 5-15P | 385 |
| | Cutting board depth — 9.0" | | | | | | | | | | | | |

PHONE 952-941-2270
FAX 952-941-3066
WEB www.arcticairco.com



DIMENSIONAL DRAWINGS

Specifications subject to change without notice.

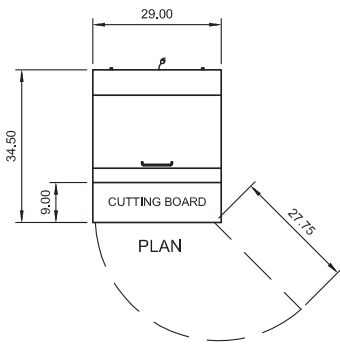

AMT28R

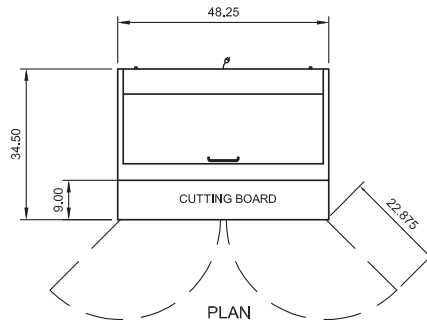

AMT48R

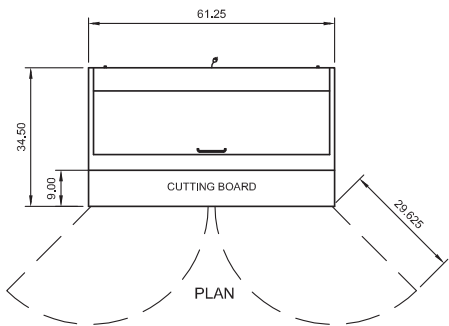
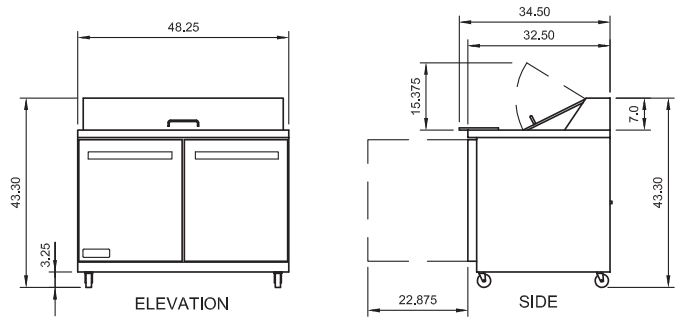
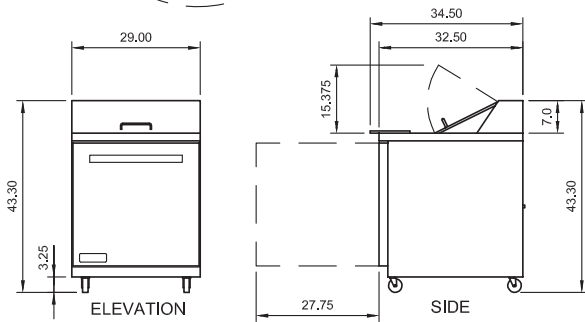

AMT60R

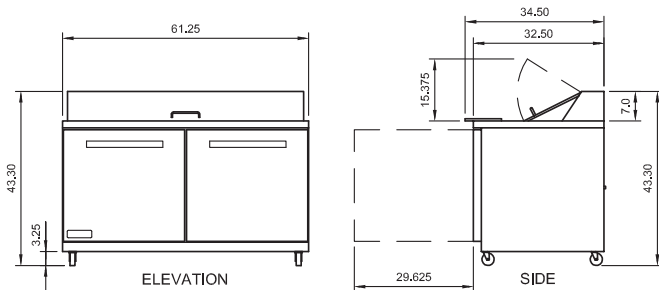

ARCTIC AIR® — A Division of Broich Enterprises, Inc. — An American Company since 1995



- Top is 1.5" solid foamed stainless steel.
- Self-contained capillary tube system using environmentally friendly CFC free refrigerant (R290).
- Front accessible condensing unit for easy cleaning and maintenance.
- Front breathing.
- Easy to mount casters (two lockable) are standard with all units.
- Electronic thermostat with digital LED display for accurate control located behind front access panel.
- Each door is equipped with magnetic gaskets that are removable for cleaning.
- 24" depth conserves important work space.
- Interior LED lighting.
- Bright stainless steel interior.
- Exterior cabinet construction consists of black powder coated steel front and sides.
- Tested to NSF Standard 7 requirements for open food storage.
- Full two year parts and labor warranty and a five year compressor warranty.

ABB48



ABB60



ABB72



Optional larger 5.75" casters available (#67000K) Set of four.

| Model Number | External Dimensions | | | Doors | Temperature Range | Cord Length | 12 oz. Cans | Amps | HP | NEMA Plug | Crated Weight (lbs.) |
|--------------|---------------------|-------|---------|-------|-------------------|-------------|-------------|------|-----|-----------|----------------------|
| | Width | Depth | Height* | | | | | | | | |
| ABB48 | 49.125" | 24.0" | 39.625" | 2 | 33°F to 41°F | 7' | 48 6-pk | 6 | 1/3 | 5-15P | 280 |
| ABB60 | 61.125" | 24.0" | 39.625" | 2 | 33°F to 41°F | 7' | 72 6-pk | 6 | 1/3 | 5-15P | 320 |
| ABB72 | 73.125" | 24.0" | 39.625" | 3 | 33°F to 41°F | 7' | 84 6-pk | 6 | 1/3 | 5-15P | 360 |

*Height includes 3.375" for casters

PHONE 952-941-2270
FAX 952-941-3066
WEB www.arcticairco.com



DIMENSIONAL DRAWINGS

Specifications subject to change without notice.

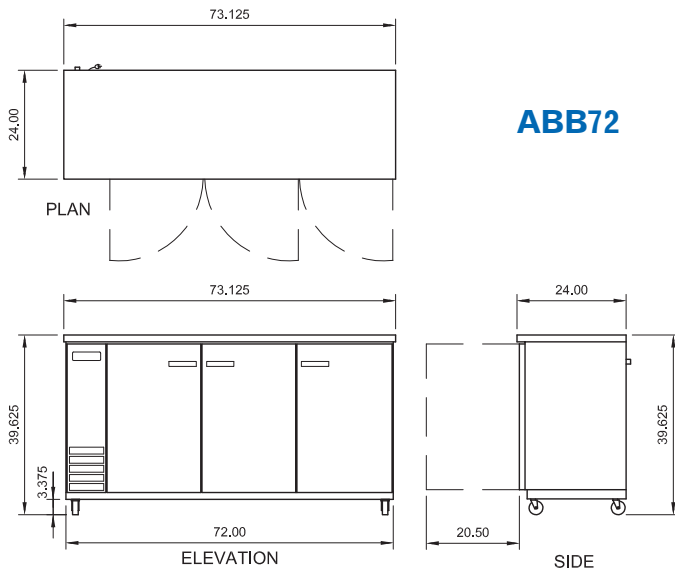
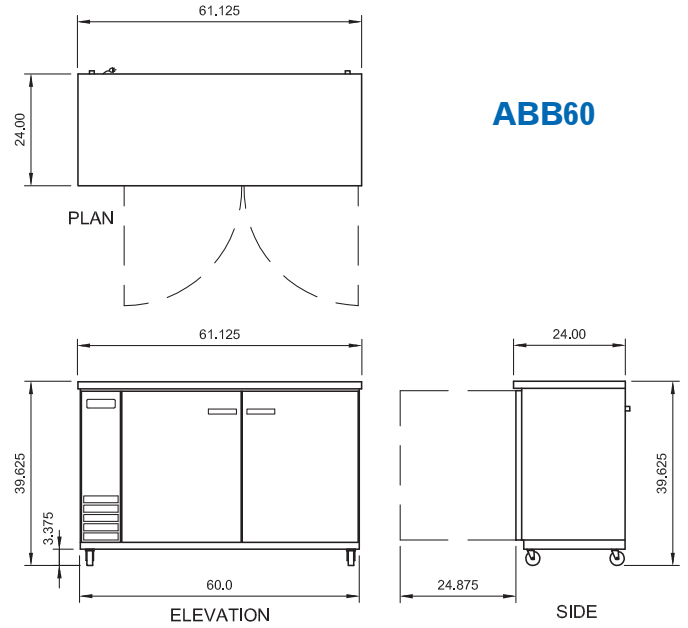
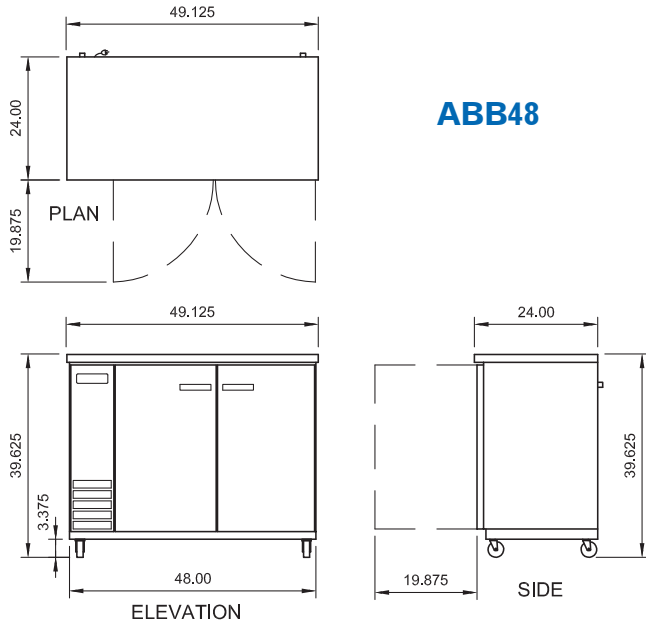

ARCTIC AIR® — A Division of Broich Enterprises, Inc. — An American Company since 1995



- Top is 1.5" solid foamed stainless steel.
- Self-contained capillary tube system using environmentally friendly CFC free refrigerant (R290).
- Front accessible condensing unit for easy cleaning and maintenance.
- Front breathing.
- Easy to mount casters (two lockable) are standard with all units.
- Electronic thermostat with digital LED display for accurate control located behind front access panel.
- Each door is equipped with magnetic gaskets that are removable for cleaning.
- 24" depth conserves important work space.
- Interior LED lighting.
- Bright stainless steel interior.
- Exterior cabinet construction consists of black powder coated steel front and sides.
- Tested to NSF Standard 7 requirements for open food storage.
- Full two year parts and labor warranty and a five year compressor warranty.

Optional larger 5.75" casters available (#67000K) Set of four.



ABB48G



ABB60G



ABB 72G

| Model Number | External Dimensions | | | Doors | Temperature Range | Cord Length | 12 oz. Cans | Amps | HP | NEMA Plug | Crated Weight (lbs.) |
|---------------|---------------------|-------|---------|-------|-------------------|-------------|-------------|------|-----|-----------|----------------------|
| | Width | Depth | Height* | | | | | | | | |
| ABB48G | 49.125" | 24.0" | 39.625" | 2 | 33°F to 41°F | 7' | 48 6-pk | 6 | 1/3 | 5-15P | 320 |
| ABB60G | 61.125" | 24.0" | 39.625" | 2 | 33°F to 41°F | 7' | 72 6-pk | 6 | 1/3 | 5-15P | 365 |
| ABB72G | 73.125" | 24.0" | 39.625" | 3 | 33°F to 41°F | 7' | 84 6-pk | 6 | 1/3 | 5-15P | 410 |

*Height includes 3.375" for casters

PHONE 952-941-2270
FAX 952-941-3066
WEB www.arcticairco.com



DIMENSIONAL DRAWINGS

Specifications subject to change without notice.

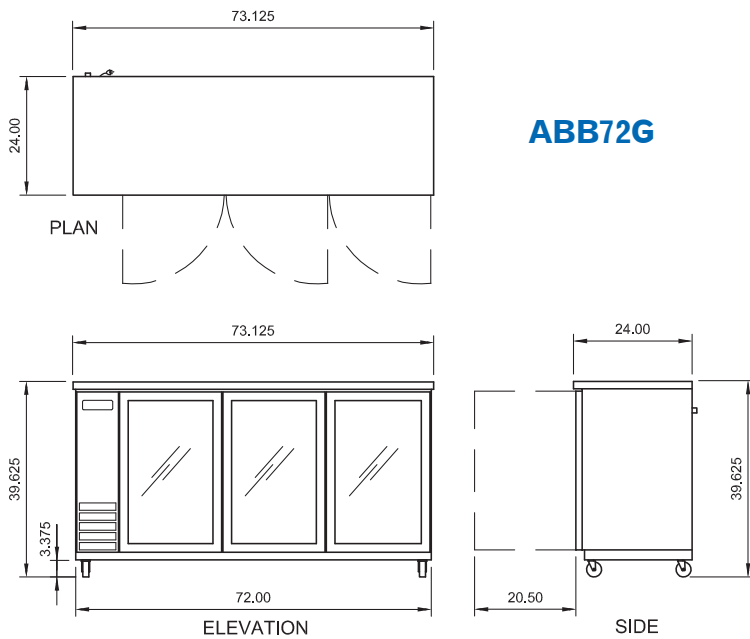
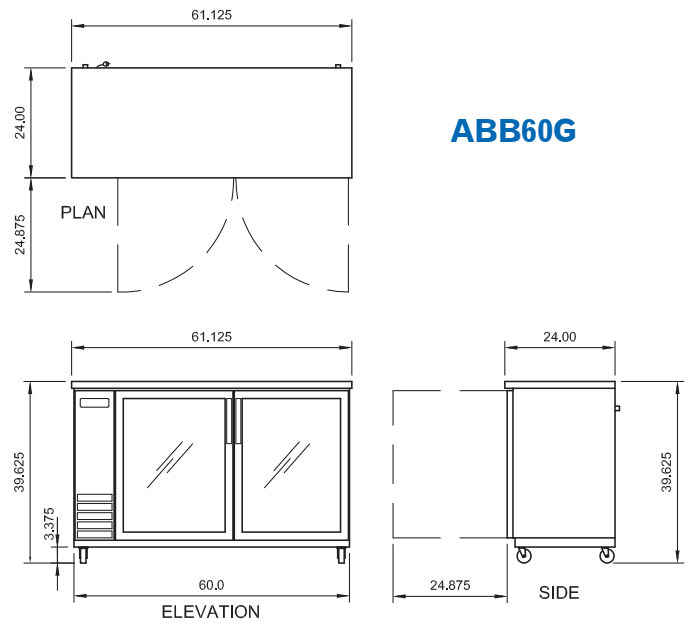
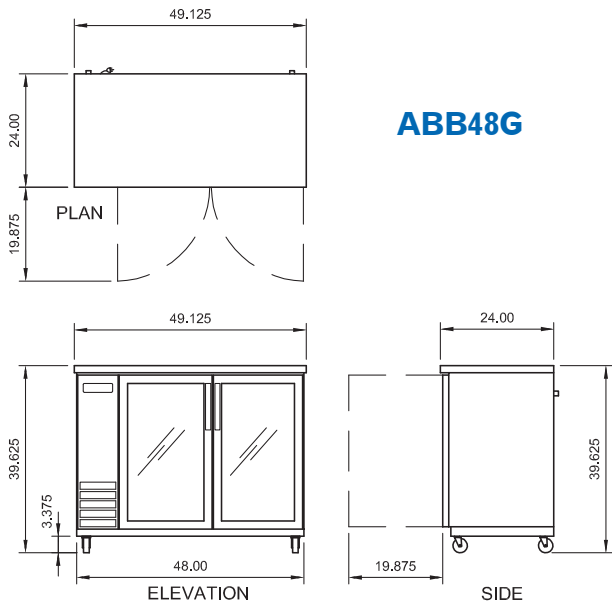

ARCTIC AIR® — A Division of Broich Enterprises, Inc. — An American Company since 1995





Direct Draw Beer Refrigerators

- All models standard with two towers and two faucets per tower.
- Top is 1.5" solid foamed stainless steel.
- Electronic thermostat with digital LED display for accurate control located behind front access panel.
- Self-contained capillary tube system using environmentally friendly CFC free refrigerant (R290).
- Front breathing.
- Front accessible condensing unit for easy cleaning and maintenance.
- Reinforced stainless steel floor.
- External drain mount.
- Easy to mount 3.25" casters (two lockable) are standard with all units.
- Mounted 4-way air distributor.
- Interior LED lighting.
- Bright stainless steel interior.
- 24" depth conserves important work space.
- Each door is equipped with locks and magnetic gaskets that are removable for cleaning.
- Exterior cabinet construction consists of black powder coated steel front and sides.
- Tested to NSF Standard 7.
- Full two year parts and labor warranty and a five year compressor warranty.



ADD48R-2



ADD60R-2



ADD72R-2

All models include internal air and liquid hoses (keg couplers, gauges and CO2 tanks supplied by others)

Optional larger 5.75" casters available (#67000K) Set of four.

| Model Number | External Dimensions | | | Doors | Temperature Range | Cord Length | Amps | HP | NEMA Plug | Crated Weight (lbs.) |
|-----------------|---------------------|-------|---------|-------|-------------------|-------------|------|-----|-----------|----------------------|
| | Width | Depth | Height* | | | | | | | |
| ADD48R-2 | 49.0" | 24.0" | 39.5" | 2 | 33°F to 41°F | 7' | 6 | 1/3 | 5-15P | 290 |
| ADD60R-2 | 61.0" | 24.0" | 39.5" | 2 | 33°F to 41°F | 7' | 6 | 1/3 | 5-15P | 325 |
| ADD72R-2 | 73.0" | 24.0" | 39.5" | 3 | 33°F to 41°F | 7' | 6 | 1/3 | 5-15P | 375 |

*Height includes 3.25" for casters

PHONE 952-941-2270
FAX 952-941-3066
WEB www.arcticairco.com



DIMENSIONAL DRAWINGS

Specifications subject to change without notice.

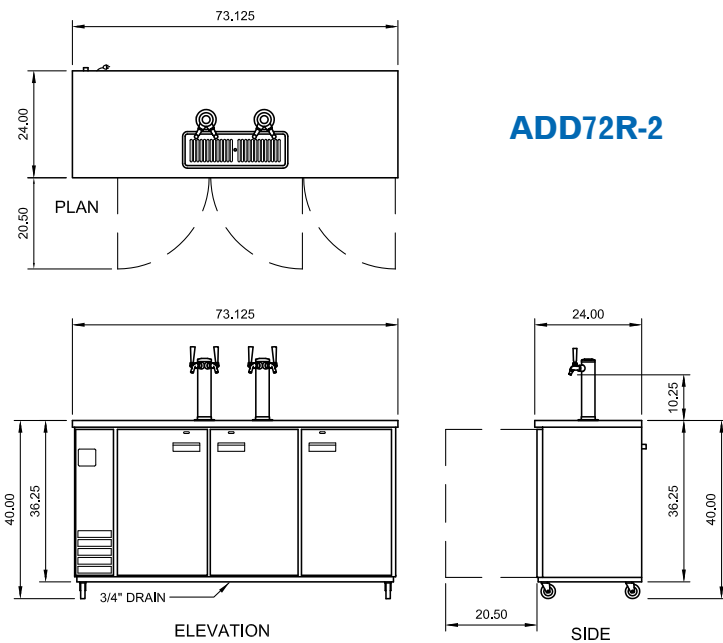
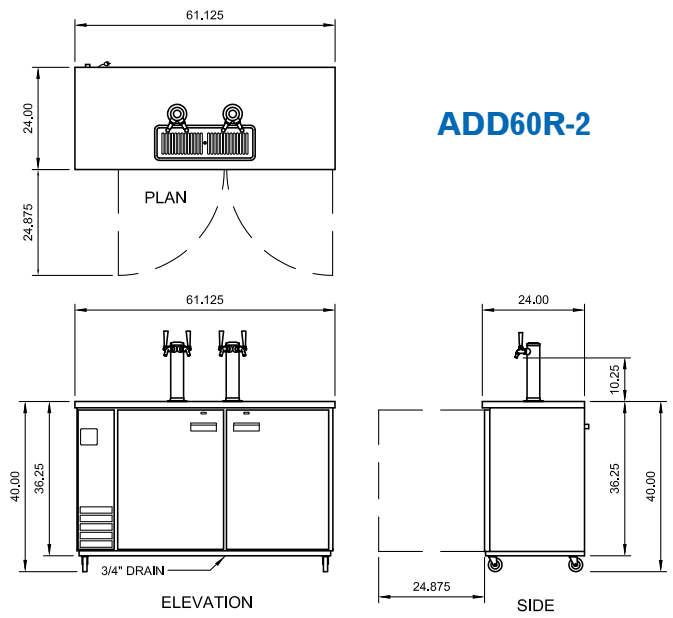
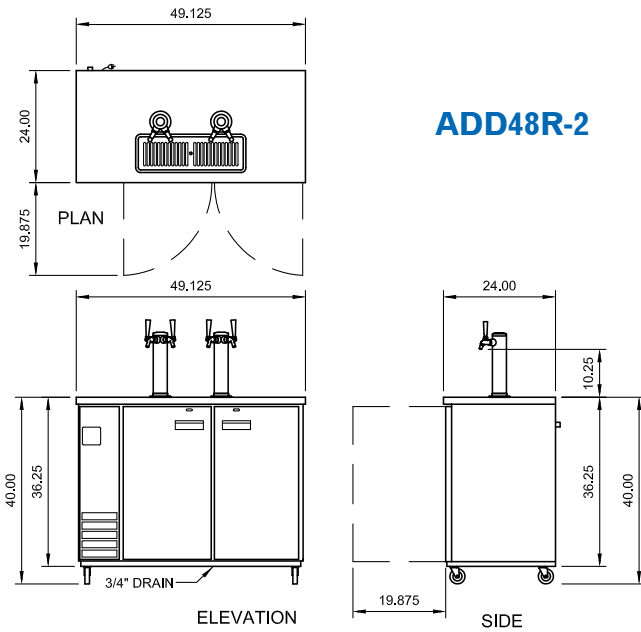

KEG SIZE COLOR KEY

- Standard Half Keg
- 1/4 Slim Keg



ARCTIC AIR® — A Division of Broich Enterprises, Inc. — An American Company since 1995



- Electronic thermostat with digital LED display for accurate control located behind front access panel.
- Exterior cabinet construction consists of black powder coated steel front and sides.
- Self-contained capillary tube system using environmentally friendly CFC free refrigerant (R290).
- Easy to mount casters (two lockable) are standard with all units.
- Stainless steel sliding lids with locks.
- Stainless steel bottle opener and cap catcher included.
- 24" depth conserves important work space.
- Interior LED lighting.
- Bright stainless steel interior.
- Front accessible condensing unit for easy cleaning and maintenance.
- Front breathing.
- Tested to NSF Standard 7 requirements for open food storage.
- Full two year parts and labor warranty and a five year compressor warranty.

Model AUB36R has 0 can dividers.

Model AUB50R has 2 can dividers.

Model AUB65R has 3 can dividers.

(Part #69436)

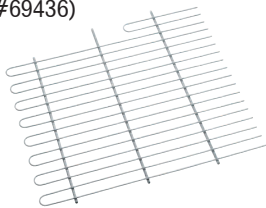

AUB36R



AUB50R



AUB65R



| Model Number | External Dimensions | | | Sliding lids with locks | Temperature Range | Capacity 12 oz. bottles/cans | Cord Length | Amps | HP | NEMA Plug | Crated Weight (lbs.) |
|---------------|---------------------|-------|---------|-------------------------|-------------------|------------------------------|-------------|------|-----|-----------|----------------------|
| | Width | Depth | Height* | | | | | | | | |
| AUB36R | 36.8" | 27.0" | 36.5" | 1 | 33°F to 41°F | 11/14.5 cases | 7' | 5 | 3/8 | 5-15P | 260 |
| AUB50R | 49.4" | 27.0" | 36.5" | 2 | 33°F to 41°F | 16.5/24 cases | 7' | 7 | 1/2 | 5-15P | 315 |
| AUB65R | 64.3" | 27.0" | 36.5" | 2 | 33°F to 41°F | 22/32.5 cases | 7' | 7 | 1/2 | 5-15P | 365 |

*Height includes 3.5" for casters

PHONE 952-941-2270
FAX 952-941-3066
WEB www.arcticairco.com



DIMENSIONAL DRAWINGS

Specifications subject to change without notice.

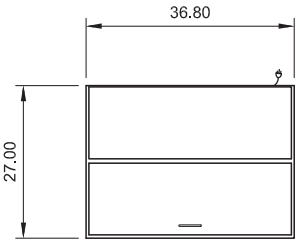

AUB36R

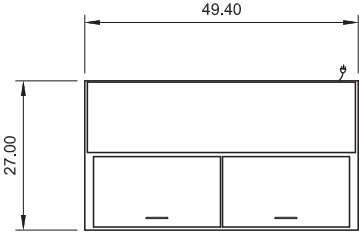

AUB50R

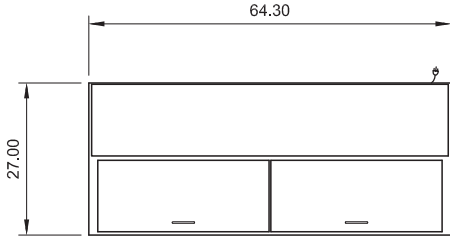
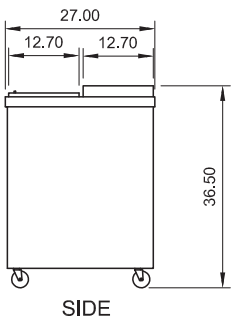
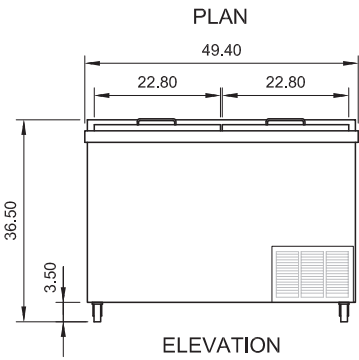
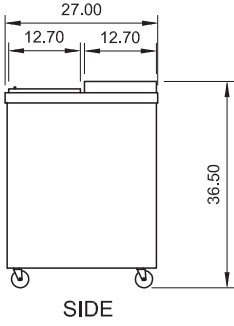
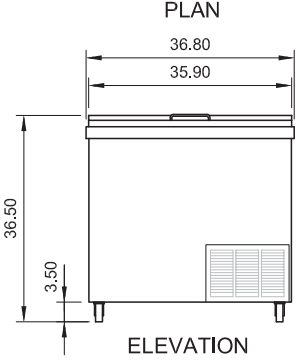

AUB65R

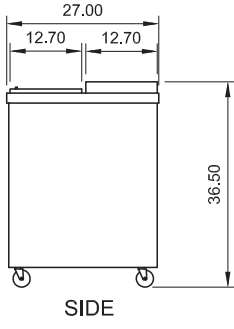
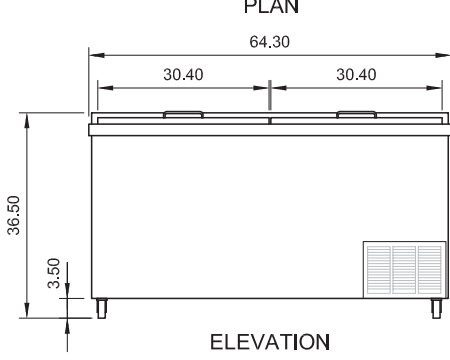

ARCTIC AIR® — A Division of Broich Enterprises, Inc. — An American Company since 1995





Arctic Air Warranty

Two-year parts & labor warranty*

Arctic Air warrants, to the original purchaser, all qualifying models of its new equipment to be free from defects in material or workmanship, under normal use and maintenance service, for a period of two (2) years from the date of original purchase or 30 months after shipment date from the manufacturer, whichever occurs first. Warranty coverage is limited to the repair and/or replacement, including labor charges, of defective parts and/or assemblies. The labor warranty shall include straight time labor charges and travel charges within 100 miles roundtrip.

* Exclusions:

- Any Arctic Air model installed in mobile application such as concession trailers, food trucks, etc. or in an outdoor venue shall be limited to one (1) year parts, labor, & compressor warranty only.
- **Models AWR25, AWF25, ACP40, ACP55, ACP4SQ, & ACPSQ are limited to one (1) year parts & labor coverage.**
- **Light bulbs and door gaskets are limited to 90-day warranty period & door hinges to one (1) year period.**

Additional three-year compressor warranty*

In addition to the two (2) year warranty stated above, Arctic Air warrants its compressor units to be free from defects in both material and workmanship under normal and proper use and maintenance service for a period of three (3) additional years from the date of original installation but not to exceed five (5) years and three (3) months after shipment from Arctic Air.

The three (3) year extended compressor warranty applies only to the compressor part itself and does not apply to any other parts, components, or labor charges involved in replacement of compressor. In addition, shipping charges for replacement compressors in the extended three-year period are not covered by this warranty and compressor replacement is limited to one (1) compressor during the three-year period.

***(Not applicable for ACP counter-top models and/or any model being used in mobile/outdoor use application)**

Conditions

All service under this warranty, for either labor or parts, must be performed by a preferred service provider arranged by the Arctic Air Warranty Center at 1-855-431-5558. Proof of purchase will be required to validate warranty coverage dates. Service coverage is limited to units located in the United States and Canada only.

Limitations & Exclusive Warranty

This parts and labor warranty is the sole and exclusive warranty remedy offered by Arctic Air. Arctic Air's sole obligation under this warranty is limited to either repair or replacement of parts and is subject to the limitations listed below.

Arctic Air will bear no responsibility or liability for any equipment which has been misapplied, mishandled, misused, subjected to harsh chemical action, or external causes such as the use of extension cords, electrical power fluctuations, lack of proper maintenance, non-factory approved revisions or modifications, or equipment damaged by fire, flood, or other acts of God.

1. Arctic Air will bear no responsibility for consequential loss or damages such as, including but not limited to, economic loss, profit loss, personal injury, property damage, damage during transit, losses or damages arising from food or product spoilage claims.
2. Arctic Air shall bear no responsibility for parts or labor coverage for component failure or other damages resulting from improper usage, installation, or maintenance as described in the owner's manual. In addition, charges that include but are not limited to ferry charges, city torch/burn permits, or labor time to access mobile units are not covered by this warranty.
3. Arctic Air equipment is intended for commercial use only and this warranty is void if the equipment is installed in other than commercial applications.
4. All other warranties, either express or implied, arising under law or equity or custom of the trade, including but not limited to, warranties or merchantability or fitness for a particular purpose are excluded.



ARCTIC AIR® — A Division of Broich Enterprises, Inc. — An American Company since 1995

PHONE 952-941-2270
FAX 952-941-3066
WEB www.arcticairco.com

© 2017 Broich Enterprises. All rights reserved. Arctic Air Brand and Logo are registered trademarks of Broich Enterprises. Prices and products subject to change without prior written notice.