

AGRICULTURAL MACHINERY
sitrex®
Spa

SPARE PARTS LIST FLEX-WING MOWERS

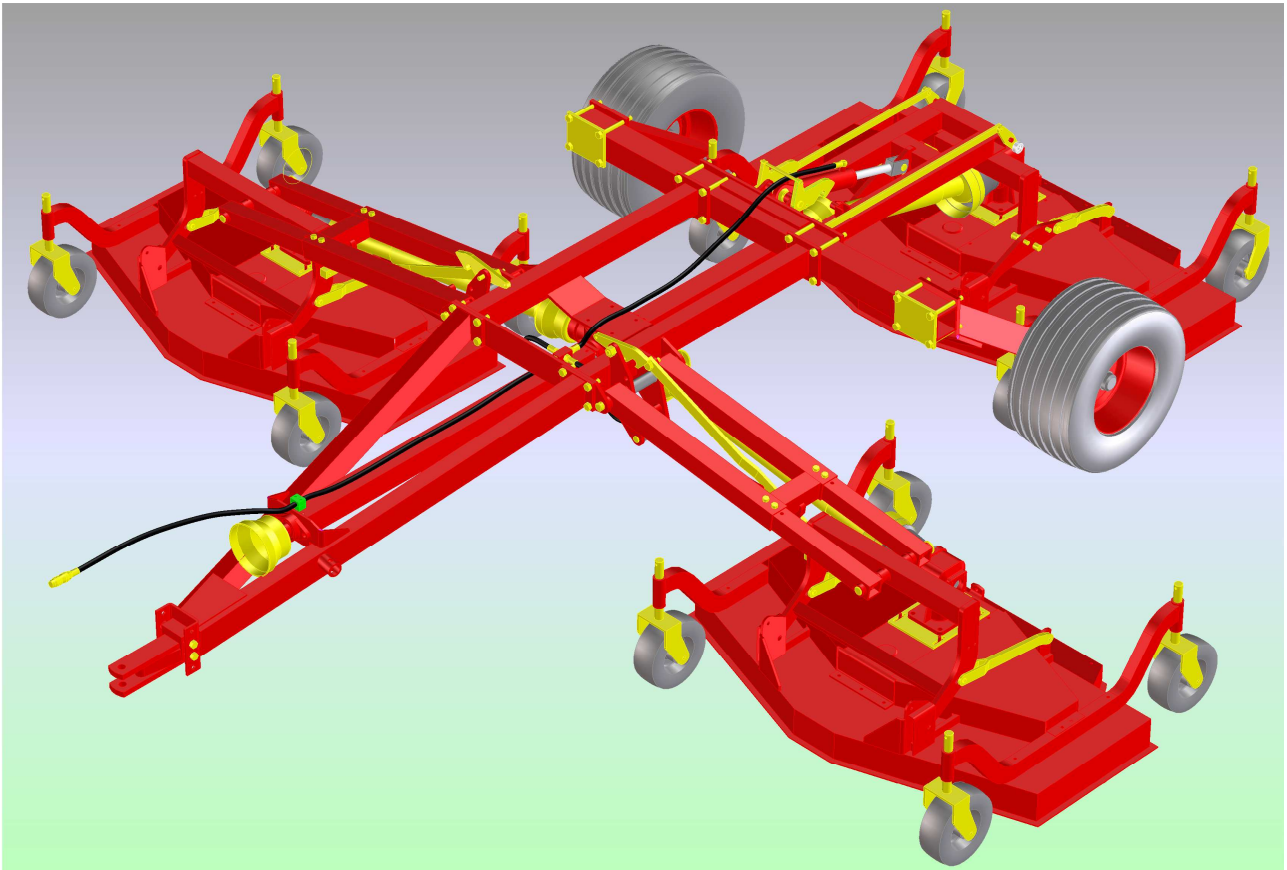

SM/3600

2008

TABLE NO. 910.072

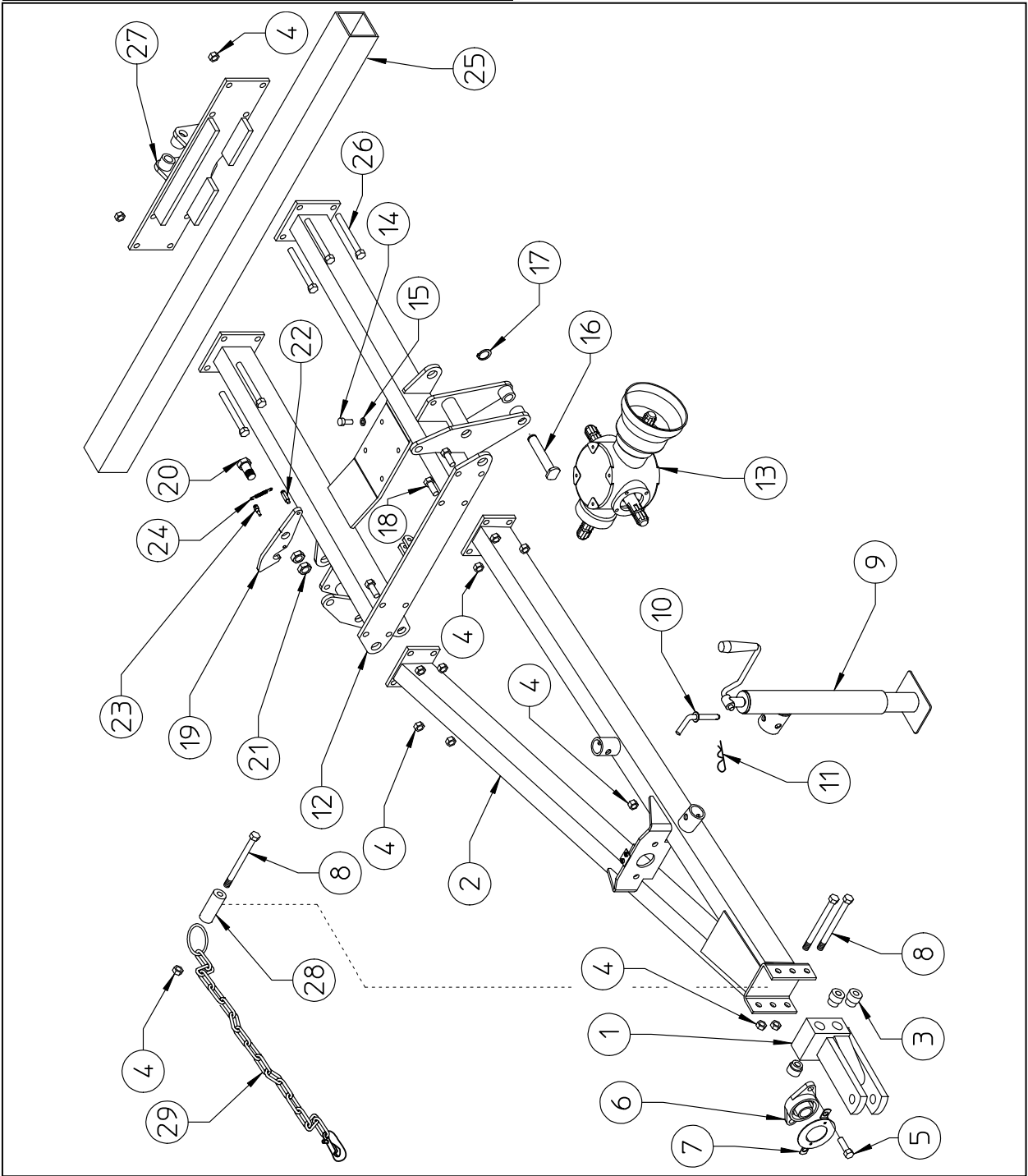

PARTS LIST 910.072 - DRAWBAR - FRAME SM/3600			
ITEM	DESCRIPTION	Q.ty	PART NO
1	BRACKET	1	210.306/c
2	DRAWBAR	1	100.769
3	SPACER	4	100.595
4	NUT M16 DIN 980	21	600.080
5	SCREW M16x45 DIN 931	2	610.167
6	BEARING	1	620.119
7	SUPPORT	1	100.768
8	SCREW M16x160 DIN 931	3	600.780
9	PARKING STAND	1	220.197
10	PIN	1	200.222
11	CLIP ø3	1	600.019
12	FRAME	1	110.306
13	GEARBOX	1	620.860
14	SCREW M12x30	4	600.004
15	SPRING WASHER ø13 SIMILAR TO 127B	4	600.049
16	PIN	1	100.608
17	SNAP RING E25 DIN 471	1	600.316
18	SCREW M16x45 DIN 931	8	610.167
19	HOOK	1	100.615
20	PIN	1	100.614
21	NUT M24x2 DIN 936	2	610.150
22	PIN	1	100.672
23	PIN	1	100.671
24	SPRING	1	220.123
25	OUTER CROSSPIECE	1	100.616
26	SCREW M16x140 DIN 931	8	600.595
27	COUNTER PLATE	1	100.617
28	BUSH	1	110.329
29	SAFETY CHAIN	1	220.500

TABLE NO. 910.074

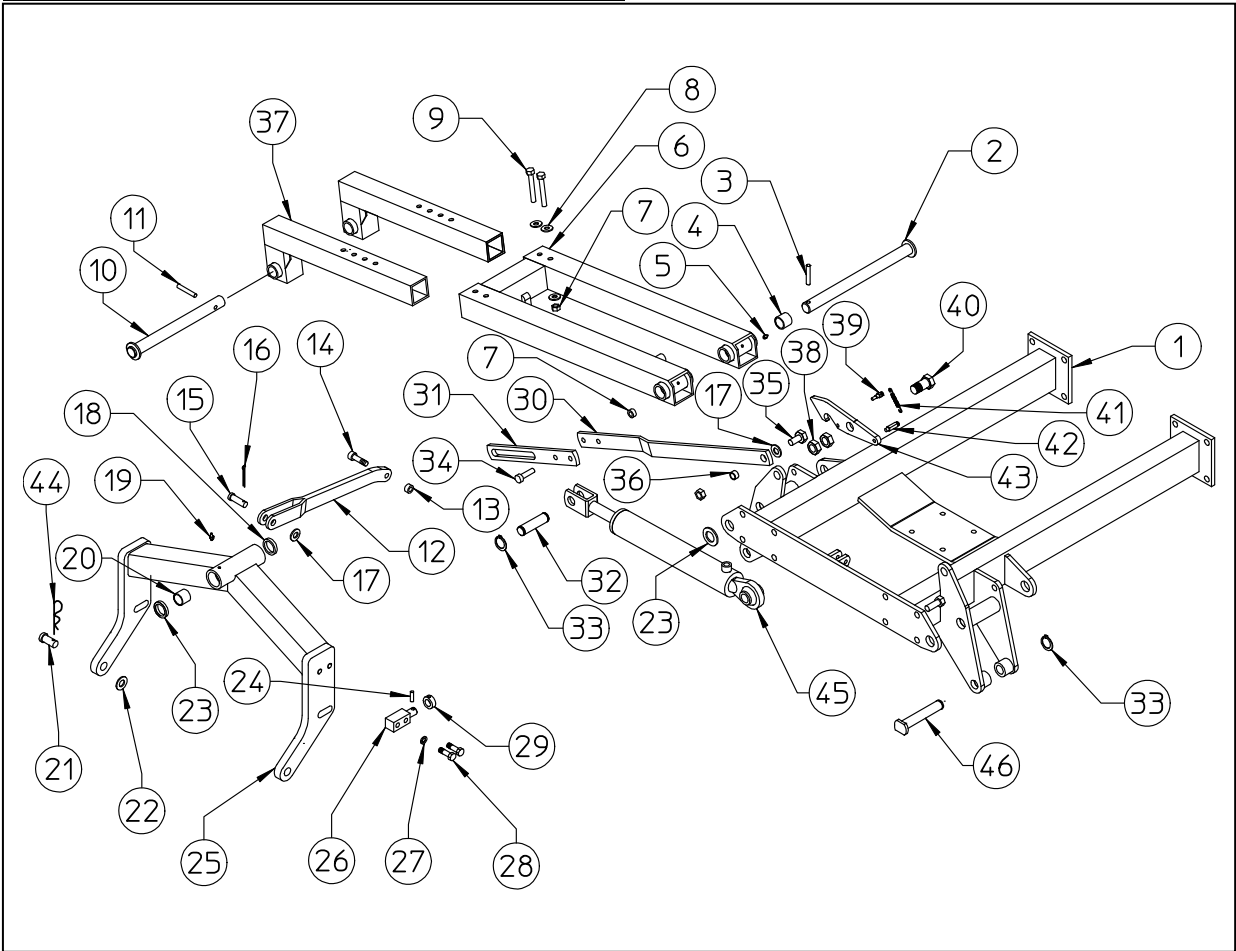

PARTS LIST 910.074 - FRAME - ARM R.H. SM/3600			
ITEM	DESCRIPTION	Q.ty	PART NO
1	FRAME	1	110.306
2	PIN	1	100.607
3	SPRING PIN ϕ 10x50 DIN 1481	1	600.584
4	BUSH	4	600.808
5	GREASE NIPPLE M8	2	600.034
6	ARM R.H.	1	100.724
7	NUT M12 DIN 980	6	600.077
8	WASHER D 13x36x4	8	600.845
9	SCREW M12x95 DIN 931	4	620.509
10	PIN	1	100.610
11	SPRING PIN ϕ 10x50 DIN 1481	1	600.584
12	TIE ROD	2	110.098
13	NUT M16 DIN 980	2	600.080
14	SCREW M16x60 DIN 931	2	600.174
15	PIN	2	110.087
16	SPLIT PIN ϕ 4x30 DIN 94	2	600.112
17	WASHER ϕ 17 DIN 125A	4	600.031
18	SHIM	1	100.142
19	GREASE NIPPLE M6	1	600.124
20	BUSH	2	600.808
21	PIN	2	110.086
22	WASHER ϕ 19 DIN 125A	2	600.756
23	SHIM	2	100.141
24	SPRING PIN ϕ 8x30 DIN 1481	1	620.468
25	FRAME	1	110.298
26	PIN	1	100.612
27	WASHER ϕ 13 SIMILAR TO DIN 127B	2	600.018
28	SCREW M12x50 DIN 931	2	600.750
29	BUSH	1	220.905
30	TIE ROD	1	110.242
31	TIE ROD	1	100.602
32	PIN	1	100.609
33	SNAP RING ϕ E25 DIN 471	3	600.316
34	SCREW M12x40 DIN 931	2	600.443
35	SCREW M16x45 DIN 931	1	610.167
36	BUSH	1	110.189
37	ARM	2	110.297
38	NUT M24x2 DIN 936	2	610.150
39	PIN	1	100.671
40	PIN	1	100.614
41	SPRING	1	220.123
42	PIN	1	100.672
43	HOOK	1	100.615
44	CLIP ϕ 3	2	600.019
45	CYLINDER	1	100.723
46	PIN	1	100.608

TABLE NO. 910.108

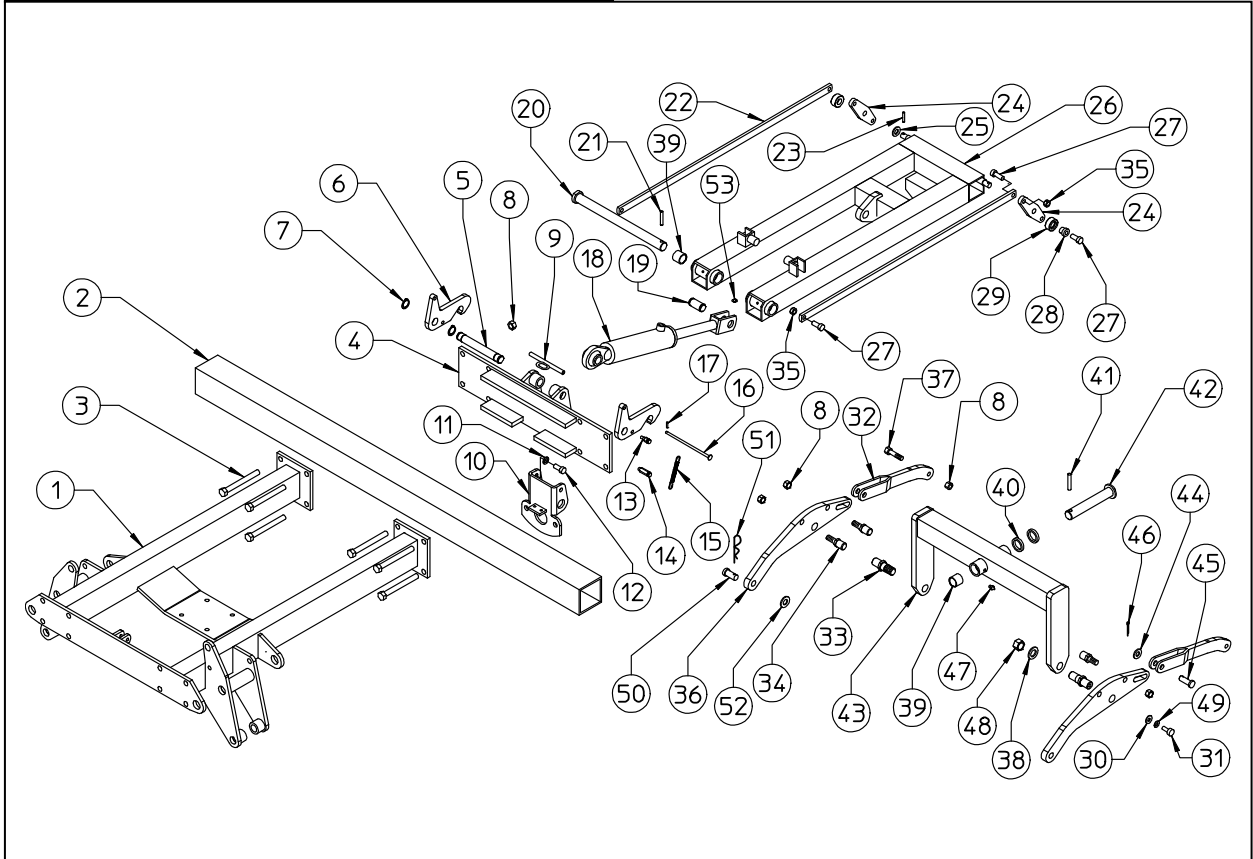

PARTS LIST 910.108 - REAR . SM/3600

ITEM	DESCRIPTION	Q.ty	PART NO
1	FRAME	1	110.306
2	OUTER CROSSPIECE	1	100.616
3	SCREW M16x140 DIN 931	8	600.595
4	COUNTER PLATE	1	100.617
5	PIN	1	100.622
6	HOOK	2	100.619
7	SNAP RING ØE25 DIN 471	6	600.316
8	NUT M16 DIN 980	14	600.080
9	SUPPORT	1	100.674
10	SUPPORT	1	100.633
11	SPRING WASHER ø13 SIMILAR TO 127B	2	600.018
12	SCREW M12x25 DIN 933	2	600.441
13	PIN	2	100.671
14	PIN	2	100.672
15	SPRING	2	220.123
16	PIN	1	100.656
17	SPRING PIN ø3,5x18 DIN 1481	1	600.841
18	CYLINDER	1	100.588
19	PIN	1	100.609
20	PIN	1	100.621
21	SPRING PIN ø10x50 DIN 1481	1	600.584
22	TIE ROD	2	100.631
23	SPRING PIN ø6x30 DIN 1481	2	600.773
24	CONNECTING ROD	2	100.629
25	WASHER D.18x28x1	2	210.658
26	FRAME	1	100.618
27	SCREW M12x35 DIN 933	6	600.616
28	BUSH	2	100.062
29	BUSH	2	100.630
30	WASHER D.12x36x2,5	2	600.092
31	SCREW M12x20 DIN 933	2	600.770
32	TIE ROD	2	110.101
33	PIN	2	100.626
34	PIN	4	100.627
35	NUT M12 DIN 936	4	600.132
36	ARM	2	100.623
37	SCREW M16x60 DIN 931	2	600.174
38	SPRING WASHER ø25 SIMILAR TO 127B	2	600.246
39	BUSH	6	600.808
40	SHIM	2	100.141
41	SPRING PIN ø10x50 DIN 1481	1	600.584
42	PIN	1	100.646
43	FRAME	1	100.620
44	WASHER ø17 DIN 125A	2	600.031
45	PIN	2	110.087
46	SPLIT PIN ø4x30 DIN 94	2	600.112
47	GREASE NIPPLE M6	1	600.124
48	NUT M24x2 DIN 980	2	600.244
49	WASHER ø13 SIMILAR TO DIN 127B	2	600.018
50	PIN	2	110.086
51	CLIP ø3	1	600.019
52	WASHER ø19 DIN 125A	2	600.756
53	GREASE NIPPLE M8	2	600.034

TABLE NO. 910.081

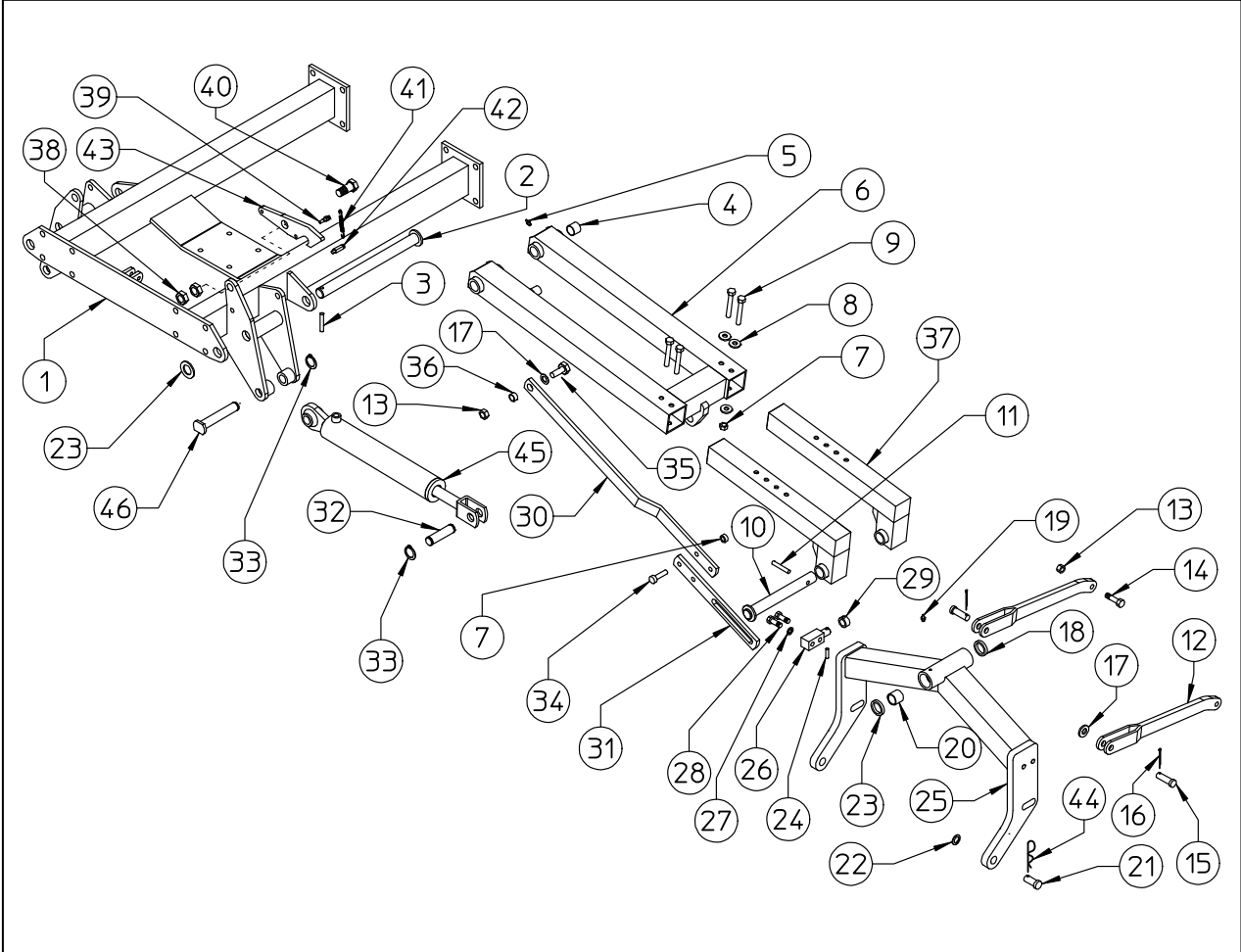

PARTS LIST 910.081 - FRAME - ARM L.H. SM/3600			
ITEM	DESCRIPTION	Q.ty	PART NO
1	FRAME	1	110.306
2	PIN	1	100.607
3	SPRING PIN ϕ 10x50 DIN 1481	1	600.584
4	BUSH	4	600.808
5	GREASE NIPPLE M8	2	600.034
6	ARM L.H.	1	100.725
7	NUT M12 DIN 980	6	600.077
8	WASHER D 13x36x4	8	600.845
9	SCREW M12x95 DIN 931	4	620.509
10	PIN	1	100.610
11	SPRING PIN ϕ 10x50 DIN 1481	1	600.584
12	TIE ROD	2	110.098
13	NUT M16 DIN 980	2	600.080
14	SCREW M16x60 DIN 931	2	600.174
15	PIN	2	110.087
16	SPLIT PIN ϕ 4x30 DIN 94	2	600.112
17	WASHER ϕ 17 DIN 125A	4	600.031
18	SHIM	1	100.142
19	GREASE NIPPLE M6	1	600.124
20	BUSH	2	600.808
21	PIN	2	110.086
22	WASHER ϕ 19 DIN 125A	2	600.756
23	SHIM	2	100.141
24	SPRING PIN ϕ 8x30 DIN 1481	1	620.468
25	FRAME	1	110.298
26	PIN	1	100.612
27	WASHER ϕ 13 SIMILAR TO DIN 127B	2	600.018
28	SCREW M12x50 DIN 931	2	600.750
29	BUSH	1	220.905
30	TIE ROD	1	110.242
31	TIE ROD	1	100.602
32	PIN	1	100.609
33	SNAP RING ϕ E25 DIN 471	3	600.316
34	SCREW M12x40 DIN 931	2	600.443
35	SCREW M16x45 DIN 931	1	610.167
36	BUSH	1	110.189
37	ARM	2	110.297
38	NUT M24x2 DIN 936	2	610.150
39	PIN	1	100.671
40	PIN	1	100.614
41	SPRING	1	220.123
42	PIN	1	100.672
43	HOOK	1	100.615
44	CLIP ϕ 3	1	600.019
45	CYLINDER	1	100.723
46	PIN	1	100.608

TABLE NO. 910.083

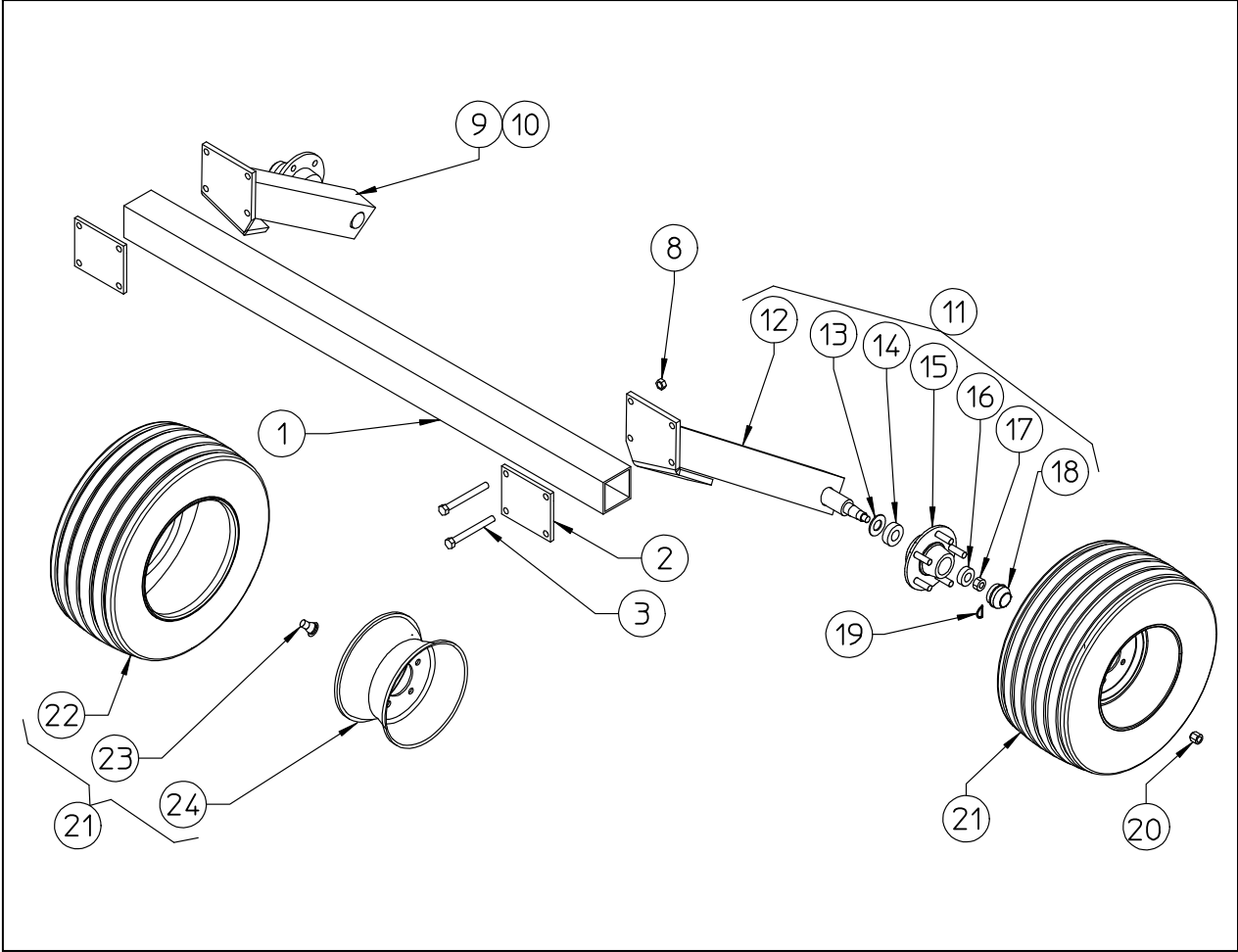

PARTS LIST 910.083 - WHELL SM/3600-4500-5200

ITEM	DESCRIPTION	Q.ty	PART NO
1	OUTER CROSSPIECE	1	100.616
2	PLATE	2	100.641
3	SCREW M16x140 DIN 931	8	600.595
4			
5			
6			
7			
8	NUT M16 DIN 980	8	600.080
9	WHEEL SUPPORT, R.H. COMPLET	1	100.688
10	WHEEL SUPPORT, R.H. WHIT ONLY PIN		100.690
11	WHEEL SUPPORT, L.H. COMPLET	1	100.689
12	WHEEL SUPPORT, L.H. WHIT ONLY PIN		100.691
13	DUST COVER		600.284
14	BEARING 30208		600.285
15	HUB		600.286
16	BEARING 30206		600.287
17	NUT M27x1,5		600.288
18	CAP		600.290
19	SPLT PIN ø3		600.291/1
20	NUT M16x1,5	10	600.289
21	WHEEL 26x12.00-12 (WHITE RIM)	2	620.838
21	WHEEL 26x12.00-12 (GREY RIM)	2	620.023
22	TIRE		620.034
23	VALVE		620.101
24	RIM (WHITE RIM)		620.839
24	RIM (GREY RIM)		620.036

TABLE NO. 910.111

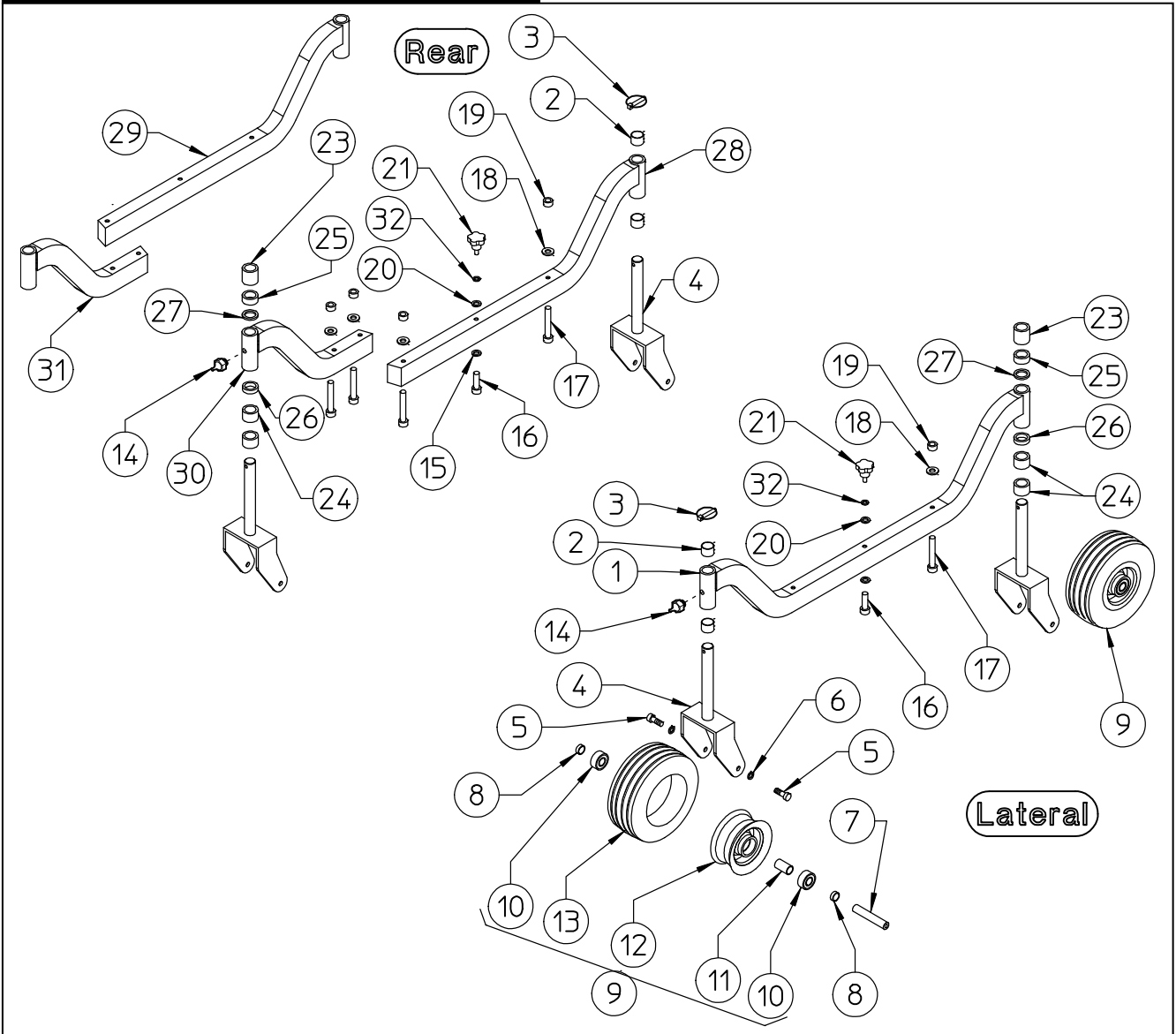

PARTS LIST 910.111 - WHEEL SM/3600			
ITEM	DESCRIPTION	Q.ty	PART NO
1	WHEEL AXLE	4	110.081
2	BUSH D.30x34/20	24	600.808
3	SPRING PIN	12	610.466
4	WHEEL SUPPORT	12	100.655
5	SCREW M12x25 DIN 933	24	600.441
6	SPRING WASHER ϕ 13 SIMILAR TO 127B	24	600.018
7	PIN	12	100.657
8	SPACER	24	100.670
9	WHEEL 15x6.00-6 (WHITE RIM)	12	620.856
9	WHEEL 15x6.00-6 (GREY RIM)	12	620.228
10	BEARING 6205 2RS		600.602
11	SPACER		200.415
12	RIM (WHITE RIM)		620.857
12	RIM (GREY RIM)		600.637
13	TIRE		600.639
14	GREASE NIPPLE M6	12	600.124
15	SPRING WASHER ϕ 15 SIMILAR TO 127B	6	600.086
16	SCREW M14x40 DIN 933	6	600.310
17	SCREW M14x95 DIN 931	16	620.510
18	WASHER ϕ 15x40x4	16	610.231
19	NUT M14 DIN 980	16	600.075
20	WASHER ϕ 9x24x2 UNI6593	6	610.185
21	HANDLE	6	620.471
22			
23	DIST.WASHER 32mm 1"1/4	12	110.235
24	DIST.WASHER 25mm 1"	36	110.236
25	DIST.WASHER 12mm 1/2"	12	110.237
26	DIST.WASHER 6mm 1/4"	12	110.238
27	DIST.WASHER 2mm 1/16"	24	110.239
28	WHEEL AXLE L.H.	1	110.308
29	WHEEL AXLE R.H.	1	110.307
30	WHEEL AXLE L.H.	1	110.310
31	WHEEL AXLE R.H.	1	110.309

TABLE NO. 910.114

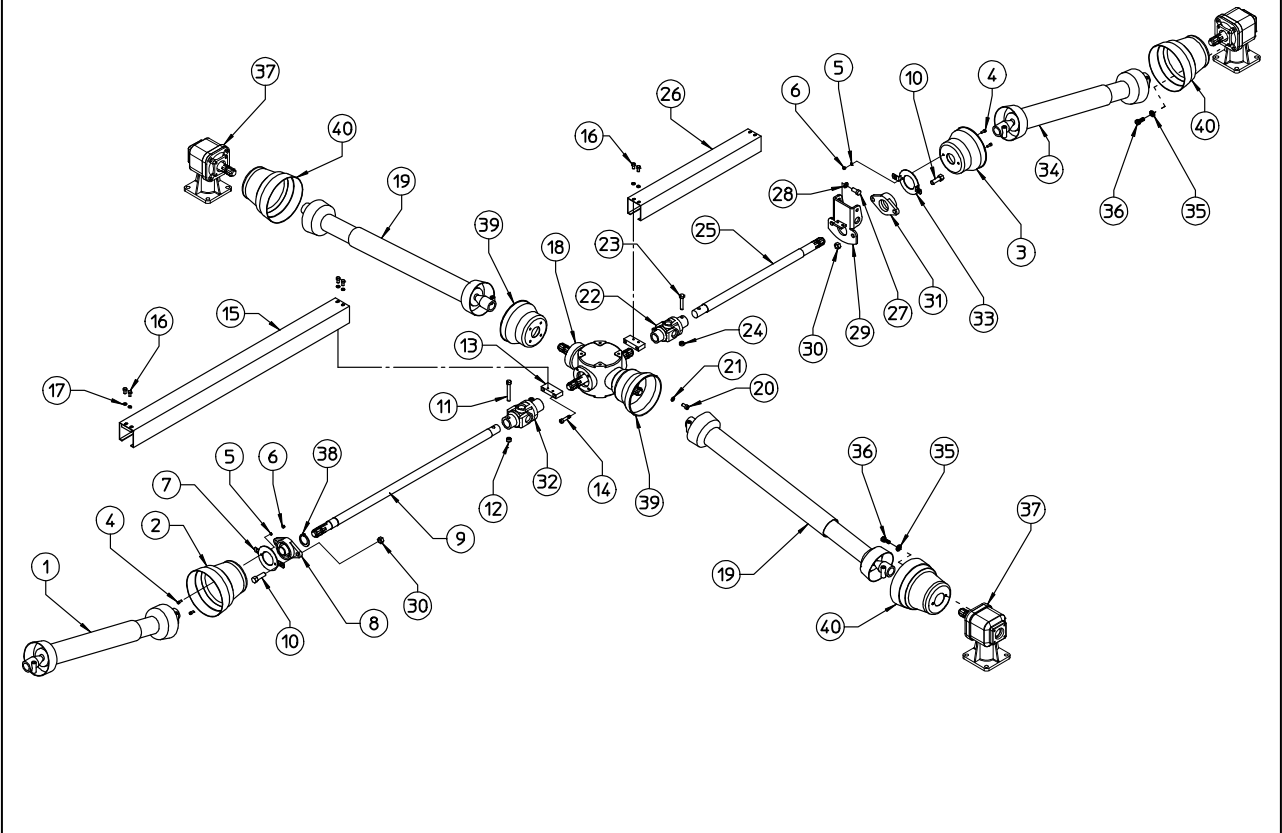

PARTS LIST 910.114 -TRASMISSION SM/3600			
ITEM	DESCRIPTION	Q.ty	PART NO
1	CARDAN SHAFT	1	620.823
2	HOOD	1	620.861
3	HOOD	1	620.522
4	SCREW M6x20 DIN 933	4	600.236
5	WASHER ϕ 6,5 UNI 6593	4	600.412
6	NUT M6 DIN 980	4	600.472
7	SUPPORT	1	100.768
8	BEARING	1	620.119
9	SHAFT	1	110.042
10	SCREW M16x45 DIN 931	4	610.167
11	SCREW M12x80 DIN 931	1	620.362
12	NUT M12 DIN 980	1	600.077
13	SUPPORT	2	100.634
14	SCREW TCEI M10x30 DIN 912	4	620.868
15	CARTER	1	110.043
16	SCREW M8x25 DIN 933	8	600.702
17	WASHER ϕ 9 UNI 6593	8	610.185
18	GEARBOX	1	620.860
19	CARDAN SHAFT B2 080 E RL1	2	620.841
20	SCREW TCEI M10x16 DIN 912	8	610.941
21	WASHER ϕ 10 DIN 125A	8	600.322
22	JOINT	1	620.394
23	SCREW M10x65 DIN 931	1	600.528
24	NUT M10 DIN 980	1	600.029
25	SHAFT	1	110.049
26	CARTER	1	110.104
27	SCREW M12x25 DIN 933	2	600.441
28	SPRING WASHER ϕ 13 SIMILAR TO 127B	2	600.018
29	SUPPORT	1	100.633
30	NUT M16 DIN 980	4	600.080
31	BEARING	1	610.285
32	JOINT	1	620.261
33	SUPPORT	1	210.675
34	CARDAN SHAFT B2 080 E RL1	1	620.841
35	WASHER ϕ 9 UNI 6593	12	610.185
36	SCREW M8x16 DIN 933	12	600.061
37	GEARBOX	3	110.321
38	SNAP RING D40	1	600.588
39	HOOD	2	620.858
40	HOOD	3	620.859

TABLE NO. 910.077

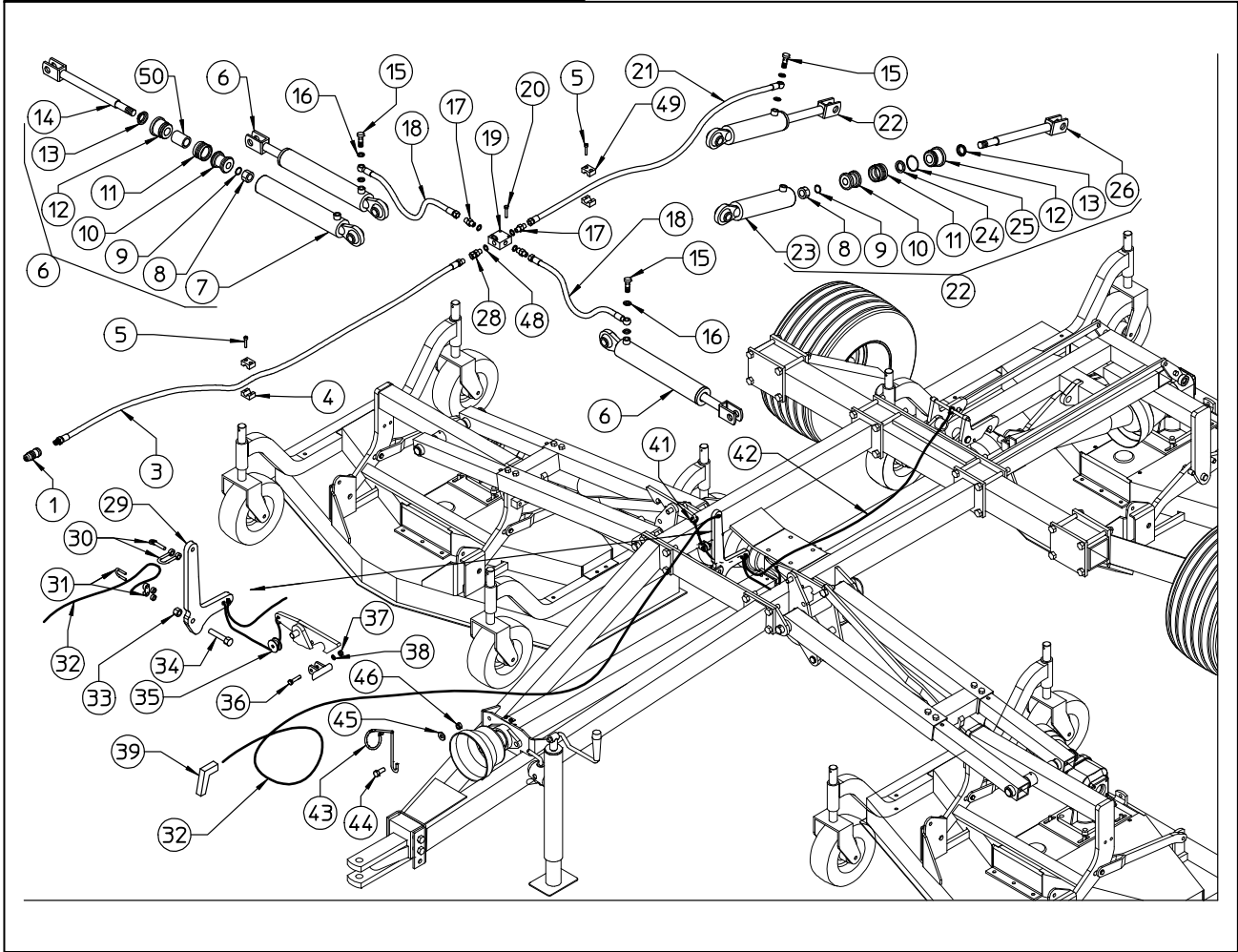

PARTS LIST 910.077 -HYDRAULIC SM/3600-4500

ITEM	DESCRIPTION	Q.ty	PART NO
1	RAPID COUPLING 1/2"	1	620.329
2			
3	HOSE SAE 100 R2AT 3/8" FG3/8 M1/2-14	1	620.862
4	HOSE COLLAR	2	610.035
5	SCREW M6x25 DIN 912	4	610.037
6	CYLINDER	2	100.723
7	CYLINDER PIPE		100.666
8	NUT		610.087
9	GASKET		600.646
10	PISTON		200.303
11	GASKET		600.647
12	HEAD		200.301
13	GASKET		600.645
14	ROD		110.339
15	FITTING	3	600.040
16	COPPER WASHER 3/8"	6	600.039
17	FITTING M3/8 M3/8 D. 0,8	3	200.192
18	HOSE SAE 100 R2AT 3/8 F3/8 - O.3/8	2	610.968
19	BLOCK	1	100.676
20	SCREW M6x40 DIN 931	2	600.870
21	HOSE SAE 100 R2AT 1/4 F3/8 - O3/8	1	610.967
22	CYLINDER	1	100.588
23	CYLINDER PIPE		100.668
24	GASKET		610.031
25	GASKET		600.875
26	ROD		100.669
27			
28	FITTING M3/8 M3/8	1	600.271
29	LEVER	1	100.715
30	FORK ASSY d.8	3	610.317
31	WIRE ROPE CLIPS	5	620.108
32	FRONT ROPE MT.3,5	1	100.716
33	NUT M10 DIN 980	1	600.029
34	SCREW M10x40 DIN 931	1	600.028
35	PULLEY	2	100.720
36	SCREW M6x35 DIN 931	2	610.803
37	NUT M6 DIN 980	2	600.472
38	WASHER D 6,5 DIN 125A	2	600.514
39	HANDLE	1	620.357
40			
41	LATERAL ROPE MT.1	1	100.718
42	REAR ROPE MT.1,5	1	100.717
43	SUPPORT	1	110.105
44	SCREW M12x35 DIN 933	1	600.616
45	WASHER D 13x36x4	1	600.845
46	NUT M12 DIN 980	1	600.077
47			
48	WASHER BONDED	4	620.452
49	HOSE COLLAR	2	610.787
50	BUSH		100.731

TABLE NO. 910.109

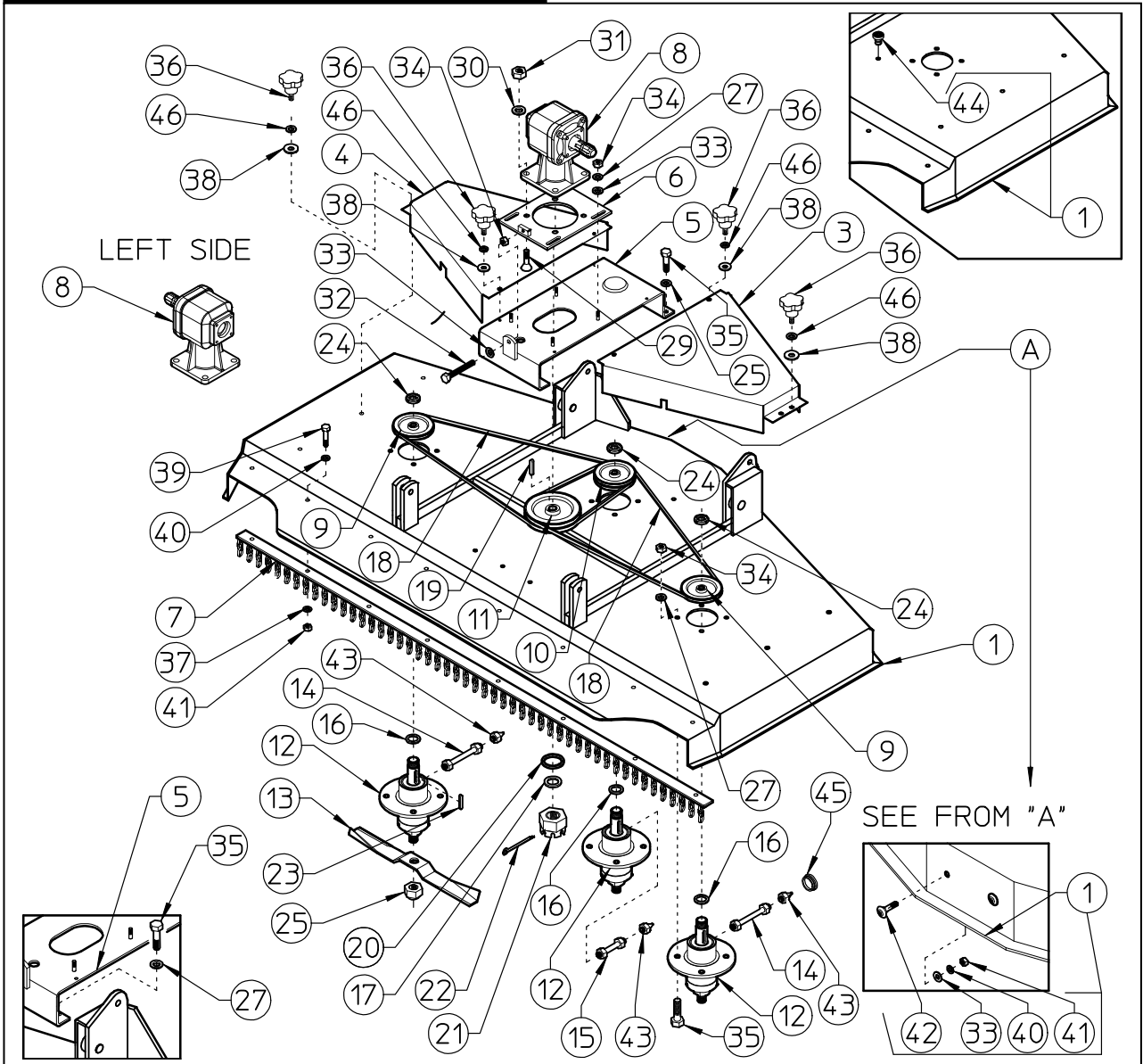

PARTS LIST 910.109 LATERAL DECK SM/3600

ITEM	DESCRIPTION	Q.ty	PART NO
1	DECK WELDMENT	1	110.091
2			
3	BELT COVER R.H.	1	110.106
4	BELT COVER L.H.	1	110.110
5	GEARBOX SUPPORT	1	100.124
6	GEARBOX SUPPORT BRACKET	1	100.022
7	DISCHARGE SHIELD	1	110.063
8	GEARBOX	1	110.321
9	PULLEY ϕ p 80-1B (17x11)	2	100.060
10	DOUBLE PULLEY ϕ p 80-2B (17x11)	1	100.059
11	DOUBLE PULLEY ϕ p 170-2B (17x11)	1	100.056
12	SPINDLE ASSEMBLY	3	110.299
13	STANDARD LIFT	3	100.064
14	TUBE LINE	2	100.125
15	TUBE LINE	1	100.577
16	SHIM	3	100.050
17	SHIM (2 mm - 0,08")	1	100.042
18	BELT B51	2	600.141
19	KEY B10x8x40 DIN 6885	1	600.181
20	WASHER ϕ 25 DIN 125A	1	600.335
21	NUT M24x2 UNI 5594	1	600.296
22	SPLIT PIN ϕ 5x50 DIN 94	1	600.347
23	KEY B8x7x35 DIN 6885	3	600.123
24	LOCKING RING NUT M25x1,5	3	600.122
25	NUT M18x1,5 DIN 980	3	600.746
26			
27	SPRING WASHER ϕ 10,5 SCHNORR S10	22	600.102
28			
29	SCREW M14x40 SIMILAR TO DIN 7991	4	600.158
30	SPRING WASHER ϕ 14,5 SCHNORR S14	4	600.104
31	NUT M14 DIN 980	4	600.075
32	SCREW M10x80 DIN 933	1	600.160
33	WASHER ϕ 10,5 DIN 125A	7	600.322
34	NUT M10 DIN 934	17	600.010
35	SCREW M10x25 DIN 933	18	600.006
36	HANDLE	6	620.471
37	SPRING WASHER ϕ 8,5 SCHNORR S8	6	600.100
38	LARGE WASHER ϕ 9-24x2 UNI 6593	6	610.185
39	SCREW M8x25 DIN 933	6	600.702
40	WASHER ϕ 8,4 DIN 125A	8	600.115
41	NUT M8 DIN 934	8	600.037
42	SCREW M8x20 DIN 603	2	610.661
43	GREASE NIPPLE M8	3	600.034
44	PLUG	3	620.816
45	PLUG	3	110.222
46	SPRING WASHER ϕ 8,5 SIMILAR TO 127B	6	600.229

SPARE PARTS

TABLE NO. 910.107

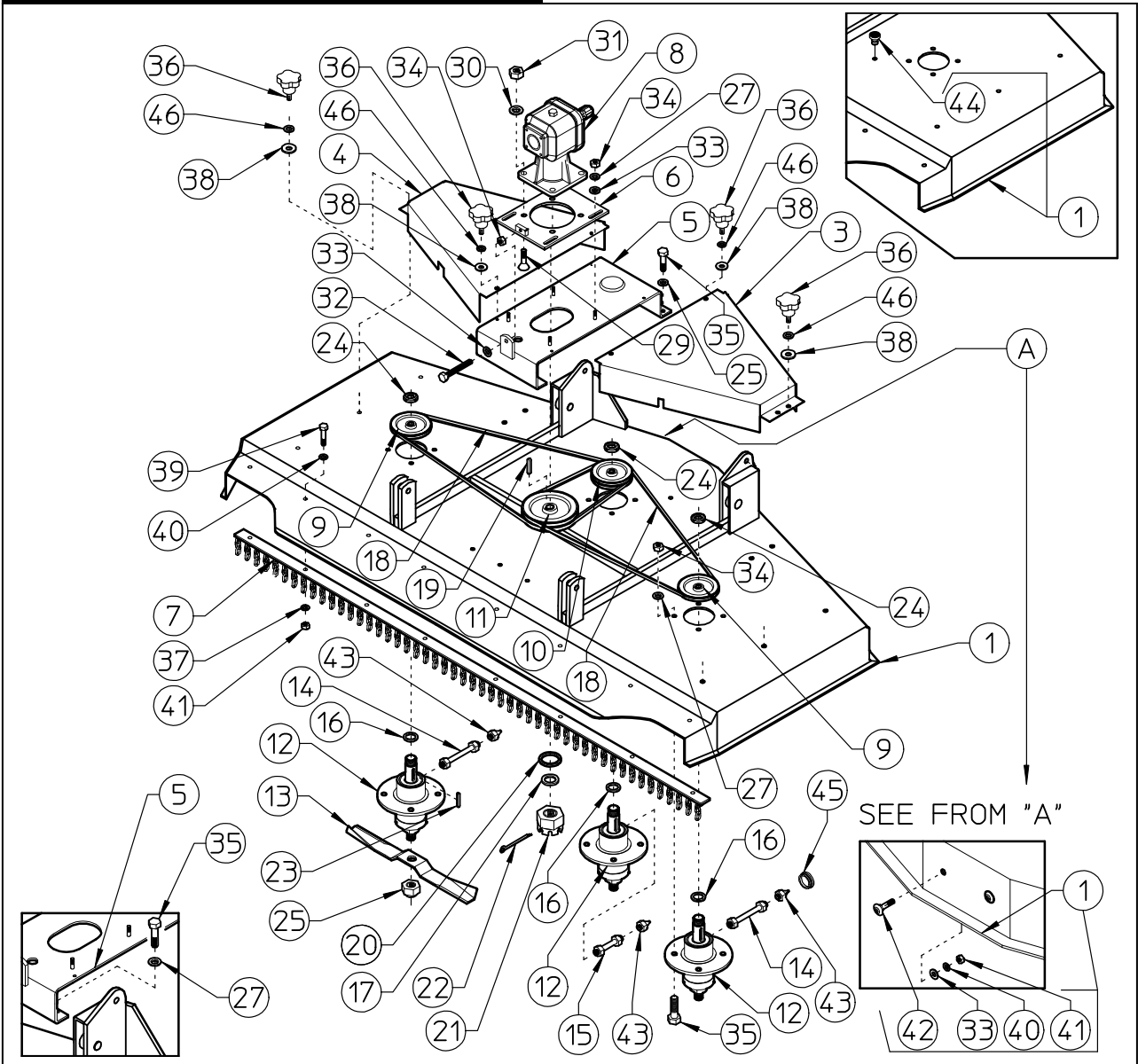

PARTS LIST 910.107 REAR DECK SM/3600

ITEM	DESCRIPTION	Q.ty	PART NO
1	DECK WELDMENT	1	110.092
2			
3	BELT COVER R.H.	1	110.107
4	BELT COVER L.H.	1	110.111
5	GEARBOX SUPPORT	1	100.131
6	GEARBOX SUPPORT BRACKET	1	100.021
7	DISCHARGE SHIELD	1	110.064
8	GEARBOX	1	110.321
9	PULLEY øp 130-1B (17x11)	2	100.058
10	DOUBLE PULLEY øp 130-2B (17x11)	1	100.057
11	DOUBLE PULLEY øp 224-2B (17x11)	1	100.054
12	SPINDLE ASSEMBLY	3	110.299
13	STANDARD LIFT	3	100.065
14	TUBE LINE	2	100.125
15	TUBE LINE	1	100.577
16	SHIM	3	100.050
17	SHIM (2 mm - 0,08")	1	100.042
18	BELT B67 (B68)	2	600.139
19	KEY B10x8x40 DIN 6885	1	600.181
20	WASHER ø25 DIN 125A	1	600.335
21	NUT M24x2 UNI 5594	1	600.296
22	SPLIT PIN ø 5x50 DIN 94	1	600.347
23	KEY B8x7x35 DIN 6885	3	600.123
24	LOCKING RING NUT M25x1,5	3	600.122
25	NUT M18x1,5 DIN 980	3	600.746
26			
27	SPRING WASHER ø10,5 SCHNORR S10	22	600.102
28			
29	SCREW M14x40 SIMILAR TO DIN 7991	4	600.158
30	SPRING WASHER ø14,5 SCHNORR S14	4	600.104
31	NUT M14 DIN 980	4	600.075
32	SCREW M10x80 DIN 933	1	600.160
33	WASHER ø10,5 DIN 125A	7	600.322
34	NUT M10 DIN 934	17	600.010
35	SCREW M10x25 DIN 933	18	600.006
36	HANDLE	6	620.471
37	SPRING WASHER ø8,5 SCHNORR S8	8	600.100
38	LARGE WASHER ø9-24x2 UNI 6593	6	610.185
39	SCREW M8x25 DIN 933	8	600.702
40	WASHER ø8,4 DIN 125A	10	600.115
41	NUT M8 DIN 934	10	600.037
42	SCREW M8x20 DIN 603	2	610.661
43	GREASE NIPPLE M8	3	600.034
44	PLUG	5	620.816
45	PLUG	3	110.222
46	SPRING WASHER ø8,5 SIMILAR TO 127B	6	600.229

TABLE NO. 910.099

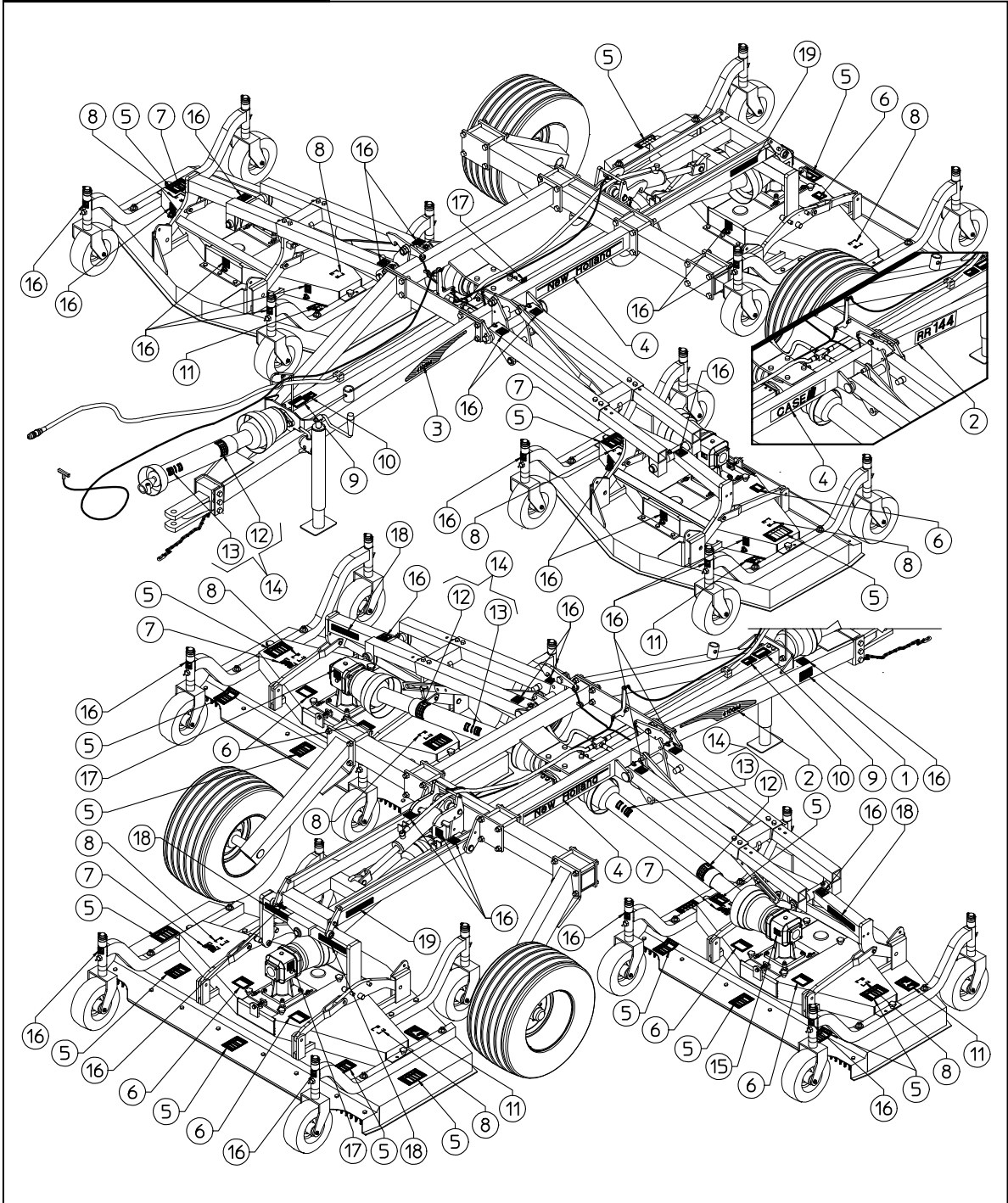

PARTS LIST - 910.099 - TAG AND LABEL FOR 144" (12') FLEX WING			
ITEM	DESCRIPTION	Q.ty	PART NO
1	NH SERIAL TAG	1	001.400
1	CIH SERIAL TAG	1	001.427
2	LABEL "410GM" RH	1	001.442
2	LABEL "RR144"	2	001.444
3	LABEL "410GM" LH	1	001.443
4	LABEL "New Holland"	2	001.441
4	LABEL "CASE CIH"	2	001.430
5	LABEL "DANGER STAND CLEAR....."	15	001.404
6	LABEL "WARNING Moving....." 86626958 F	6	001.405
7	LABEL "Belt Route" FOR 60" & 72" MOWERS	3	001.406
8	LABEL "WARNING SHIELD" 86626959 K	6	001.407
9	LABEL "WARNING Before operating...."	1	001.408
10	LABEL "WARNING DO NOT Operate PTO..."	1	001.409
11	LABEL "CUTTING HEIGHT ADJUSTMENT"	3	001.459
12	LABEL "DANGER ROTATING DRIVELINE"	4	001.411
13	LABEL "DANGER SHIELD MISSING..." 849472 G	4	001.316
14	SET LABEL FOR DRIVELINE	4	001.413
15	TAG FOR STANDARD GEARBOX SIT110321	3	001.414
15	TAG FOR STANDARD GEARBOX CSE110321	3	001.428
16	LABEL "GREASE" POINT	32	001.075
17	LABEL "OIL LEVEL" POINT	4	001.074
18	LABEL RED REFLECTIVE	4	001.248
19	LABEL YELLOV REFLECTIVE	2	001.249
20	SET OF TAG AND LABEL FOR 410GM FLEX WING	1	001.438
20	SET OF TAG AND LABEL FOR RR144 FLEX WING	1	001.449

PART NO./CODE 620.860

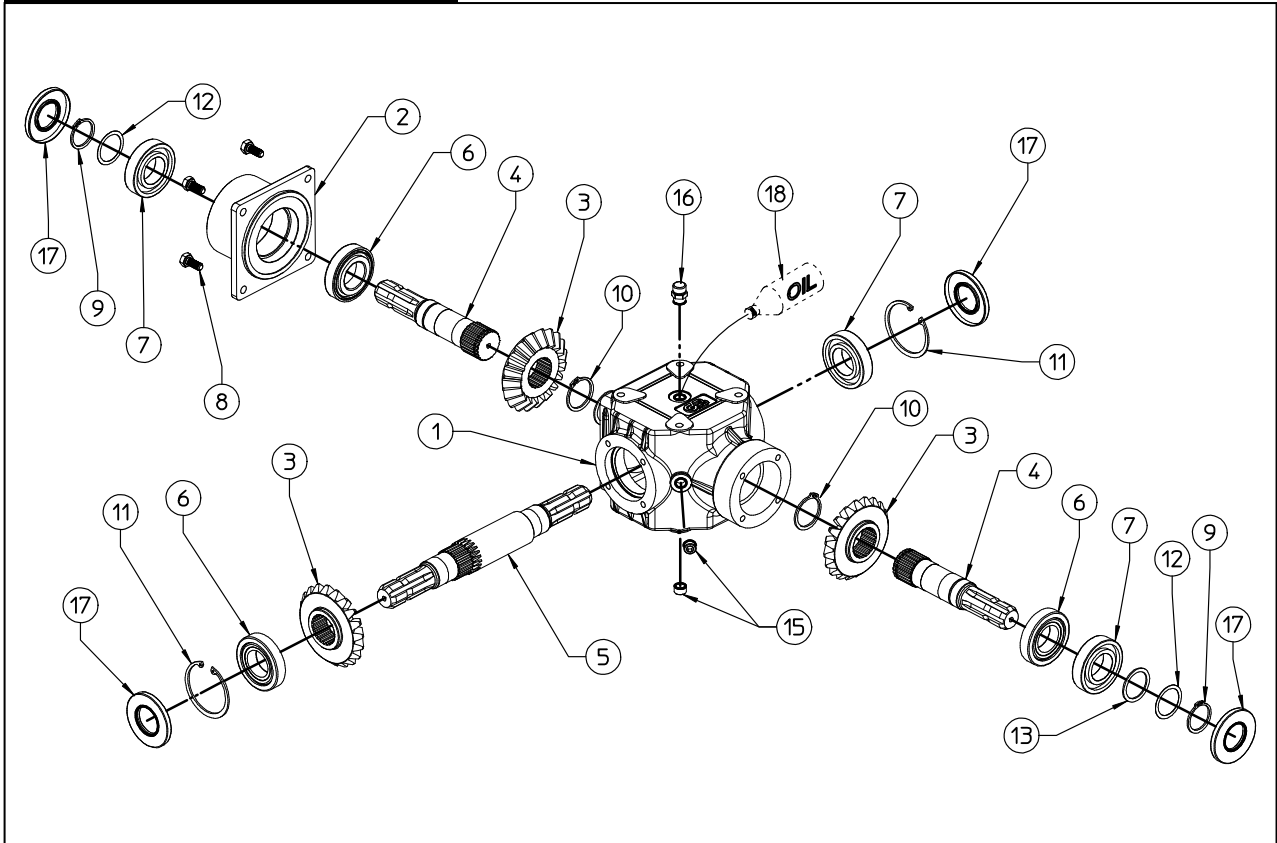

PARTS LIST 620.860 GEARBOX

ITEM	DESCRIPTION	Q.ty	PART NO
1	GEARBOX	1	620.906
2	SUPPORT	1	620.907
3	PINION	3	620.908
4	SHAFT	2	620.909
5	PTO SHAFT	1	620.910
6	BEARING 30208	3	600.285
7	BEARING 6208	3	610.197
8	SCREW M10x25 DIN933	4	600.054
9	SNAP RING E40 (REINFORCED)	2	620.911
10	SNAP RING E45 (REINFORCED)	2	620.912
11	SNAP RING I80 DIN472	2	620.480
12	SHIM 40/50 x 0.5	2	200.670
13	SHIM 40/50 x 2	2	620.913
14	SHIM 70/80 x 0.2	3	620.914
15	PLUG 3/8" DIN906	2	620.915
16	PLUG 3/8"	1	620.916
17	OIL RETAINER ϕ 40-80x8	4	620.917
18	OIL EP 80W90	*	620.675

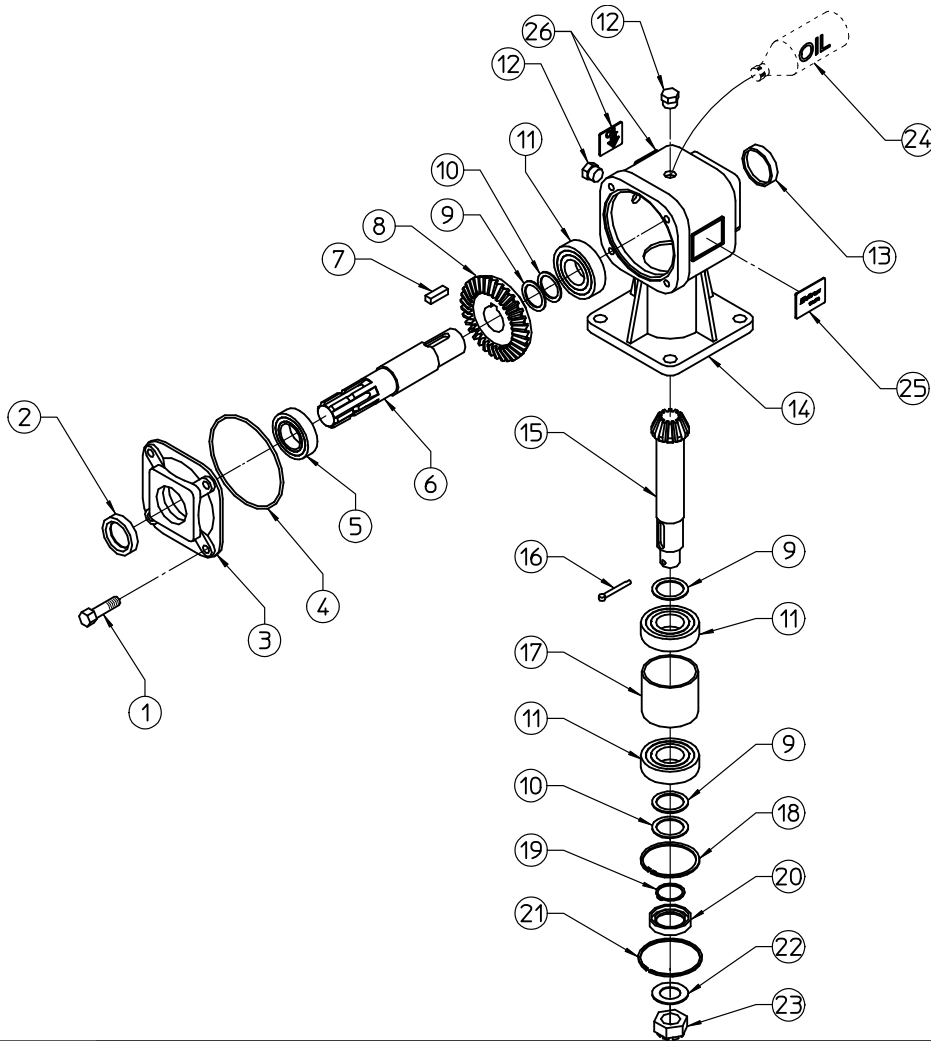

STANDARD GEARBOX 110.321(RPM 540 COUNTER CLOCK-WISE)			
ITEM	DESCRIPTION	Q.ty	PART NO
1	SCREW M10x25 DIN 933	4	600.054
2	GASKET $\phi 35-52 \times 7$	1	600.346
3	COVER	1	100.272
4	OR GASKET $\phi 117,07 \times \phi 3,53$	1	600.345
5	BEARING 6007	1	600.342
6	PTO SHAFT	1	100.268
7	KEY A10x8x30 similar to 6885	1	600.325
8	CROWN Z34	1	100.269
9	SHIM $\phi 35,2 \times 0,5$	3	200.274
10	SHIM $\phi 35,2 \times 0,3$	2	200.490
11	BEARING 6207	3	600.327
12	PLUG 3/8"	2	600.560
13	CAP	1	600.328
14	GEARBOX	1	100.267
15	PINION Z12	1	100.271
16	SPACER	1	100.270
17	SNAP RING I 72 DIN 472	1	600.332
18	SNAP RING E 35 DIN 471	1	600.333
19	GASKET $\phi 35-72 \times 10$	1	600.338
20	RING SB 72	1	600.337
21	PROTECTION	1	110.322
22	OIL EP 80W90	*	620.675
23	LABEL SIT110321	1	001.414
23	LABEL CSE110321	1	001.428
24	LABEL (OIL LEVEL)	1	001.074
25	GEARBOX ASSEMBLY	1	110.321

*LT 0,75 - GAL 0,2

SPINDLE ASSEMBLY PART NO 110.299 PARTS ILLUSTRATION

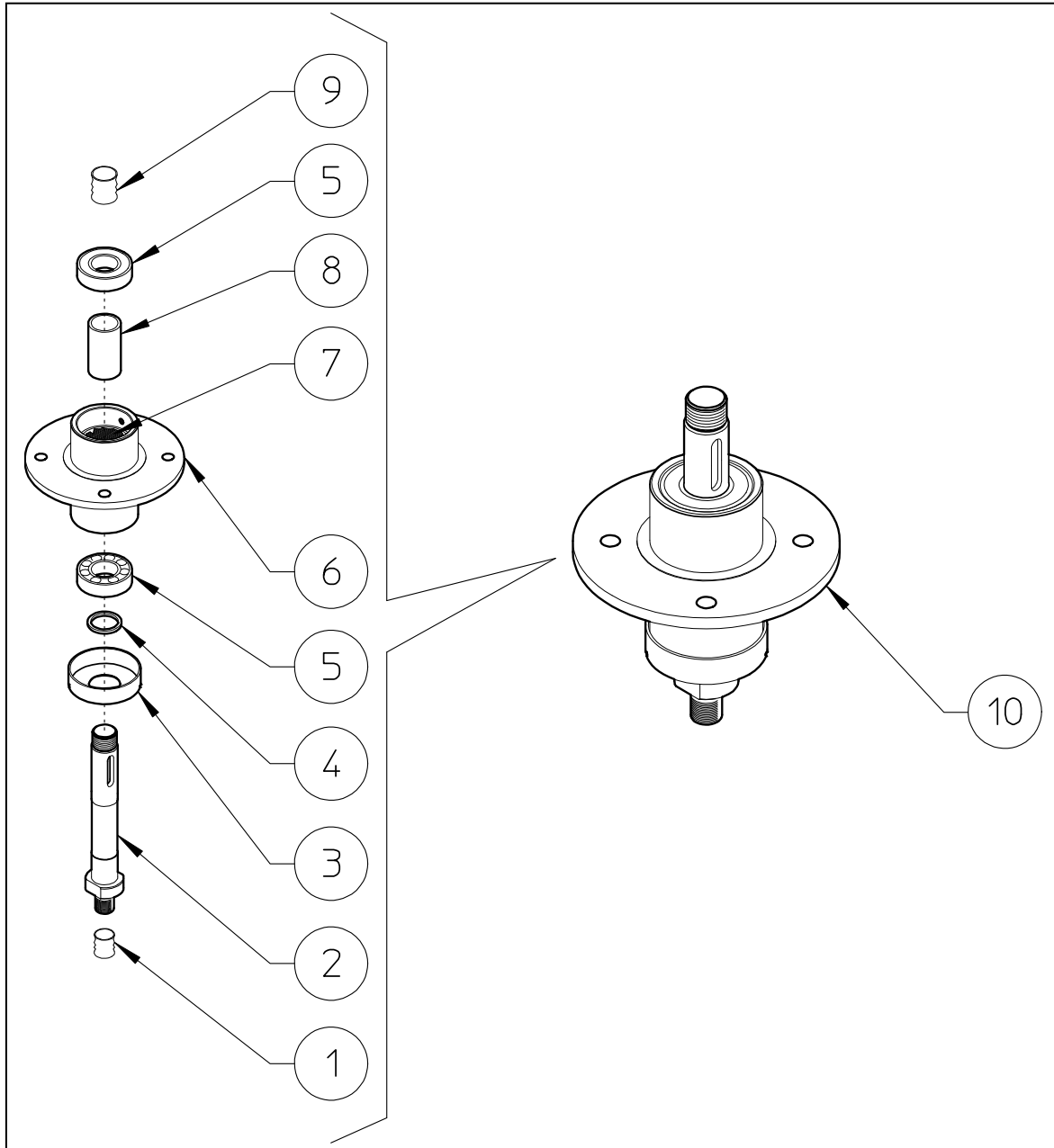

SPINDLE ASSEMBLY FOR 60"-72"-90"-144"-180"-204" MOWERS			
ITEM	DESCRIPTION	Q.ty	PART NO
1	PROTECTION	1	110.300
2	PIN	1	100.051
3	BEARING COVER	1	100.052
4	SHIM	1	100.050
5	BEARING 6205 Z	2	600.117
6	HUB	1	100.150
7	GREASE (IP ATHESIA EP 2)	*	620.676
8	SPACER	1	100.048
9	PROTECTION	1	110.301
10	SPINDLE ASSEMBLY	1	110.299

OPTIONAL

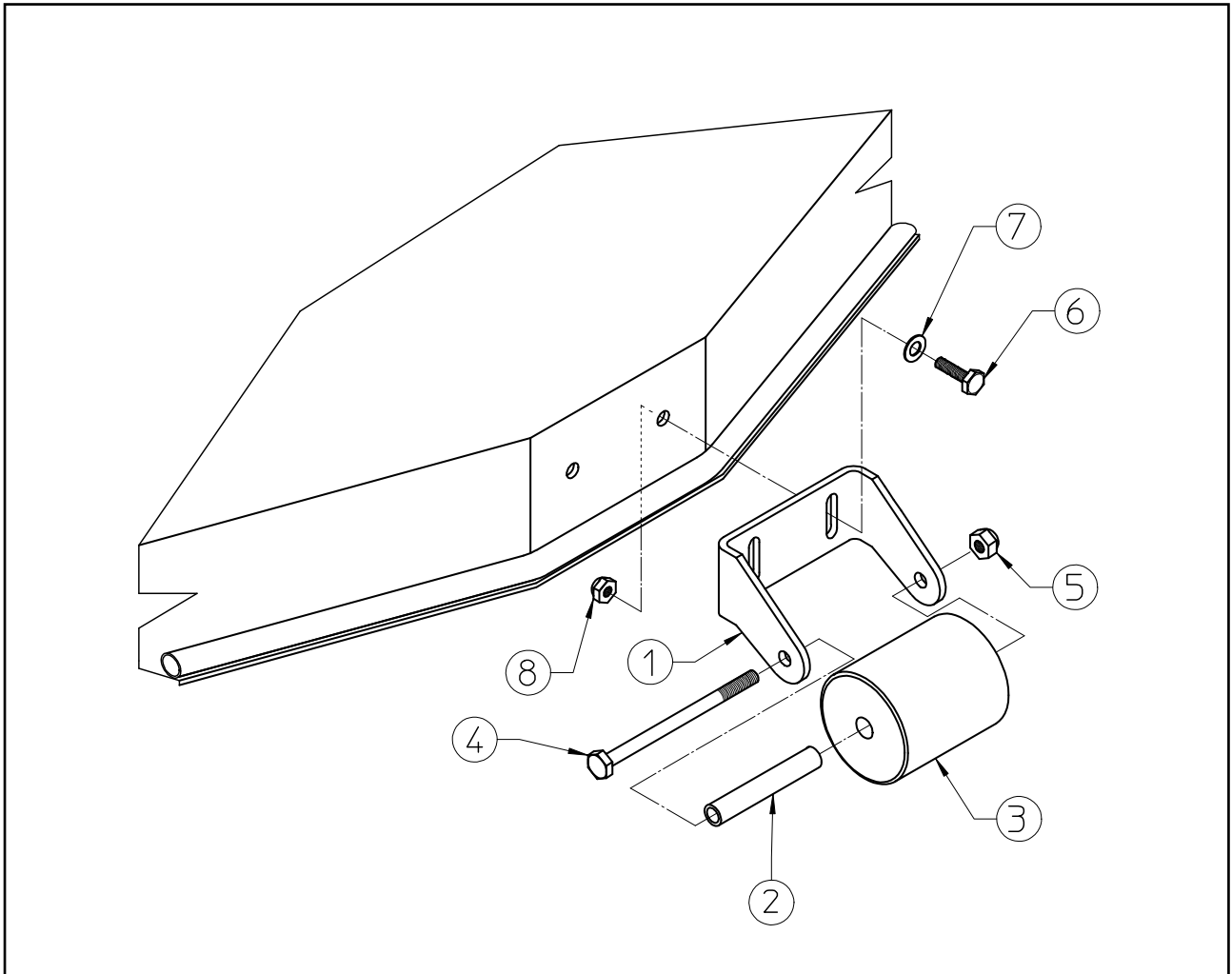

ANTI-SCALPING ROLLER KIT (OPTIONAL)

Item Pos.	Part No. Code	Q.ty	DESCRIPTION	DESCRIPTION	NOTE
1	100.258	1	SUPPORT	SUPPORT	SM/120-150-180
1	100.263	1	SUPPORT	SUPPORT	SM/230
2	100.259	1	SPACER	ENTRETOISE	SM/120-150-180
2	100.504	1	SPACER	ENTRETOISE	SM/230
3	100.260	1	ROLLER	ROULEAU	SM/120-150-180
3	100.505	1	ROLLER	ROULEAU	SM/230
4	600.807	1	SCREW M12x160 UNI 5737	VIS M12x160 UNI 5737	SM/120-150-180
4	610.676	1	SCREW M12x220 UNI 5737	VIS M12x220 UNI 5737	SM/230
5	600.077	1	NUT M12 DIN 980 KL 8	ECROU M12 DIN 980 KL 8	
6	600.006	2	SREW M10x25 UNI 5739 8.8	VIS M10x25 UNI 5739 8.8	
7	600.322	2	WASHER D.10.5 UNI 6592 ZN	RONDELLE D.10.5 UNI 6592 ZN	
8	600.029	2	NUT M10 DIN 980 KL 8 ZN	ECROU M10 DIN 980 KL 8 ZN	SM/120-150-180
*	100.364	1	ANTI SCALPING KIT , COMPLETE	GROUPE ROULEAU FRONTALE	SM/120-150-180
*	100.503	1	ANTI SCALPING KIT , COMPLETE	GROUPE ROULEAU FRONTALE	SM/230

OPTIONAL

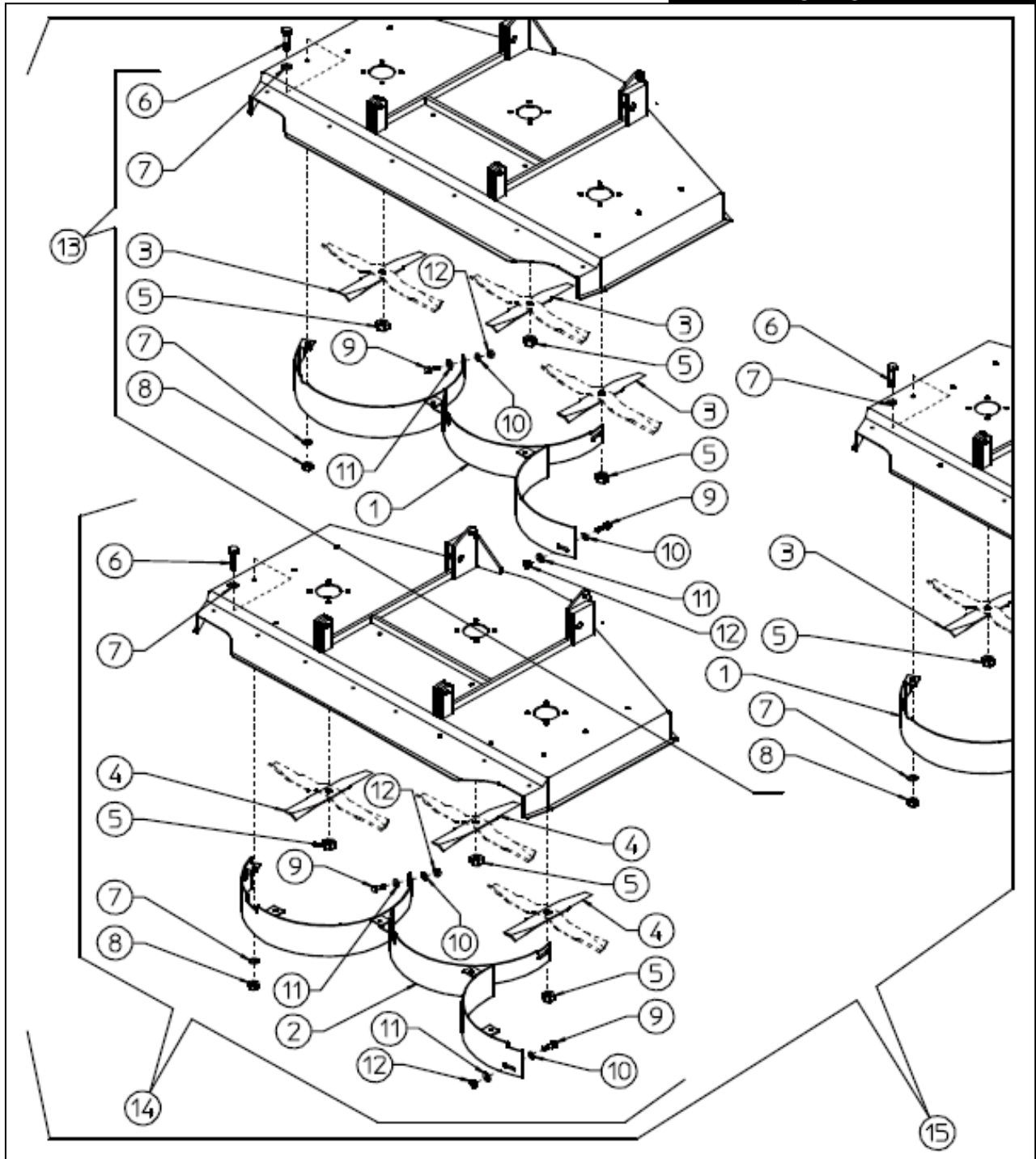

MULCH KIT - 110.286 - 12' FLEX WING			
ITEM	DESCRIPTION	Q.ty	PART NO
1	CONVEYOR 48" MOWER	2	110.323
2	CONVEYOR 60" MOWER	1	110.324
3	BLADE L.10,24" (260mm)	6	100.357
4	BLADE L.13,78" (350mm)	3	100.358
5	NUT M18x1,5	9	610.701
6	SCREW M10x25 DIN 933	11	600.006
7	WASHER ø10,5 DIN 125A	22	600.322
8	NUT M10 DIN 980	11	600.029
9	SCREW M8x20 DIN 933	9	600.223
10	WASHER ø8,4 DIN 125A	9	600.115
11	LARGE WASHER ø9-24x2 UNI 6593	9	610.185
12	NUT M8 DIN 980	9	600.076
13	MULCH KIT - 48" MOWER	2	110.282
14	MULCH KIT - 60" MOWER	1	110.283
15	MULCH KIT - 12' FLEX WING	1	110.286

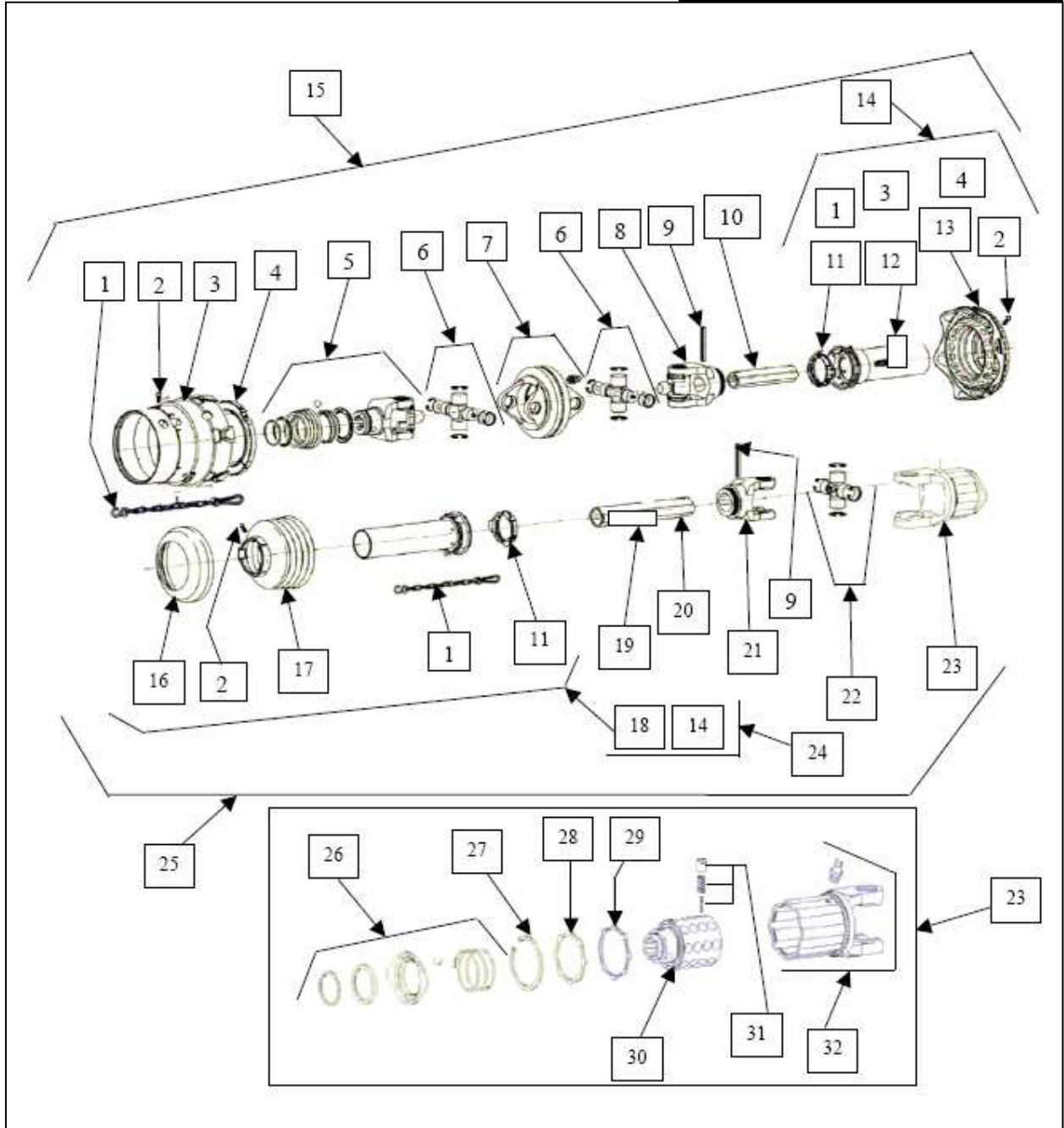

620.823			
CARDAN SHAFT WE2380SD15810K34B FOR FLEX WING			
ITEM	DESCRIPTION	Q.ty	PART NO
1	CHAIN	2	620.918
2	SPECIAL SCREW	12	620.919
3	GUARD	1	620.920
4	BEARING	1	620.921
5	YOKE	1	620.922
6	CROSS JOURNAL ASSEMBLY	2	620.923
7	CENTER JOINT	1	620.924
8	YOKE	1	620.925
9	SPRING PIN	2	620.926
10	CARDAN TUBE	1	620.927
11	BEARING	2	620.928
12	LABEL "DANGER ROTATING"	1	001.411
13	PROTECTION	1	620.929
14	HALF SAFETY GUARD	1	620.930
15	HALF SHAFT (WITH GUARD)	1	620.931
16	PROTECTION	1	620.932
17	PROTECTION	1	920.933
18	HALF SAFETY GUARD	1	620.934
19	LABEL "DANGER SHIELD..." U505 849472G	1	001.316
20	CARDAN TUBE	1	620.935
21	YOKE	1	620.936
22	CROSS JOURNAL ASSEMBLY	1	620.937
23	TORQUE K34	1	620.938
24	SAFETY GUARD	1	620.939
25	HALF SHAFT (WITH GUARD)	1	620.940
26	BALL COLLAR KIT	1	620.941
27	SNAP RING	1	620.942
28	RETAINING RING	1	620.943
29	RETAINING RING	1	620.944
30	HUB 1 3/8" Z6	1	620.945
31	SET INCLUDING NR 8 RATCHET TOOTH	4 set	620.946
32	HUB WITH YOKE	1	620.947

PART NO./CODE 620.841

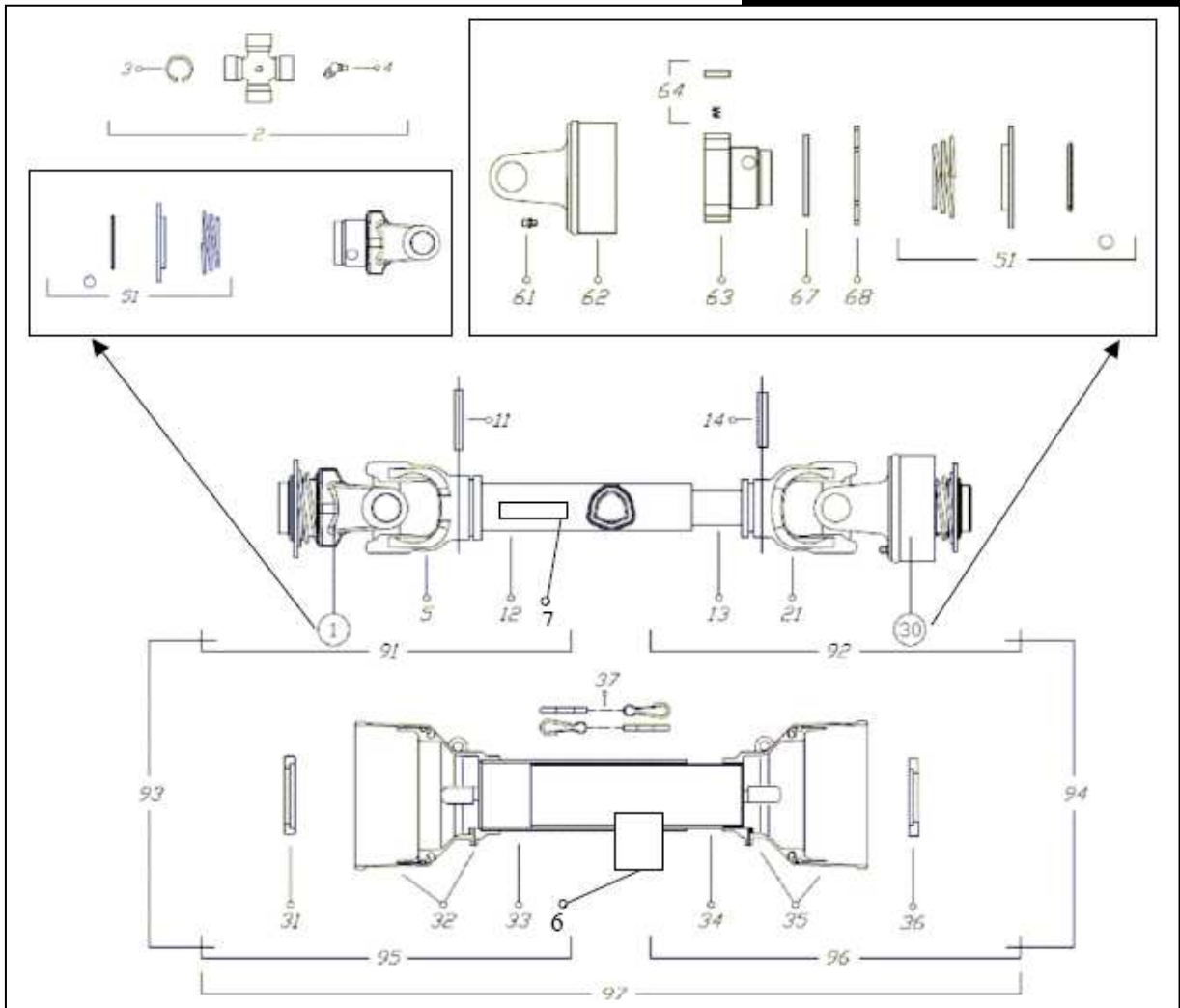

CARDAN SHAFT 620.841 B2080E089001 FOR 144"-12' & 180" -15' FLEX WING			
ITEM	DESCRIPTION	Q.ty	PART NO
1	YOKE	2	620.842
2	CROSS JOURNAL ASSEMBLY	2	610.052
3	CIRCLIP I 24 DIN 472	8	610.248
4	GREASE NIPPLE M8x1/45°	2	610.206
5	OUTER TUBE YOKE	1	610.249
6	LABEL "DANGER ROTATING"	1	001.411
7	LABEL "DANGER SHIELD..." U505 849472G	1	001.316
11	SPRING PIN ø8x55 DIN 1481	1	610.211
12	CM. 100 CARDAN TUBE	1	610.210
13	CM. 100 CARDAN TUBE	1	610.123
14	SPRING PIN ø8x50 DIN 1481	1	600.027
21	INNER TUBE YOKE	1	610.250
30	FREE WHEEL	1	620.870
31	OUTER BEARING	1	620.703
32	OUTER BASIC CONE	1	620.843
33	OUTER SAFETY TUBE	1	620.877
34	INNER SAFETY TUBE	1	620.878
35	INNER BASIC CONE	1	620.846
36	INNER BEARING	1	620.706
37	CHAIN	2	610.068
51	BALL COLLAR KIT	2	620.830
61	GREASE NIPPLE M8x1	1	610.216
62	OUTER CASING WITH YOKE	1	620.871
63	HUB 1 3/8" Z6	1	620.872
64	RATCHET TOOTH	3	620.873
67	RETAINING RING	1	620.874
68	SNAP RING	1	610.253
91	OUTER HALF SHAFT	1	620.879
92	INNER HALF SHAFT	1	620.880
93	OUTER HALF SHAFT	1	620.881
94	INNER HALF SHAFT	1	620.882
95	OUTER HALF SAFETY GUARD	1	620.883
96	INNER HALF SAFETY GUARD	1	620.884
97	SAFETY GUARD	1	620.885

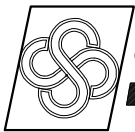

sitrex AGRICULTURAL MACHINERY[®] Spa

Zona Industriale-Viale Grecia, 8
06018 TRESTINA-(Perugia)-ITALY
Tel. +39.075.8540021-Telefax +39.075.8540523
e-mail: sitrex@sitrex.it www.sitrex.com

