

AGRICULTURAL MACHINERY
sitrex®
Spa

ASSEMBLY, USE AND MAINTENANCE SPARE PARTS LIST

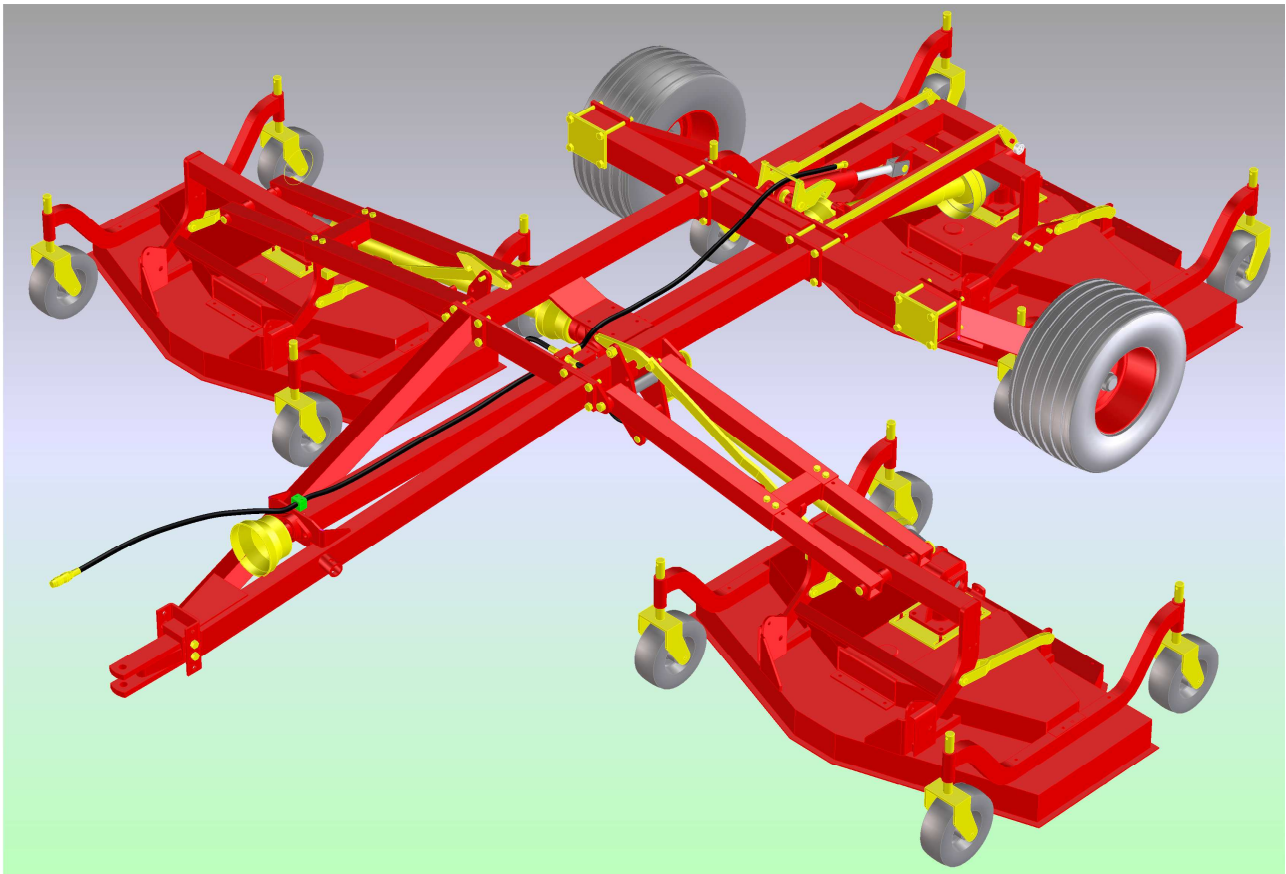

FLEX-WING MOWERS SM 3600 - 4500 - 5200

2007/1

TABLE OF CONTENT

CHAPTER 1	GENERAL INTRODUCTION - WARRANTY	3
1.1	INTRODUCTION	3
1.2	WARRANTEE	3
CHAPTER 2	GUIDE TO THE SIGNS AND SYMBOLS USED IN THIS MANUAL AND THEIR LOCATION ON THE MACHINE.....	4
2.1	SIGNS AND SYMBOLS	4
2.2	WARNING SIGNS	4
2.3	DANGER SIGNS	5
2.4	INDICATION SIGNS	7
2.5	LOCATION OF SIGNS AND SYMBOLS ON THE MACHINE	8
CHAPTER 3	GENERAL SUMMARY OF SAFETY AND ACCIDENT - PREVENTION INSTRUCTIONS	10
3.1	GENERAL SUMMARY OF SAFETY AND ACCIDENT-PREVENTION INSTRUCTIONS	10
CHAPTER 4	PRODUCT IDENTIFICATION	13
4.1	TECHNICAL DATA	13
4.2	MAIN MACHINE PARTS	13
CHAPTER 5	DELIVERY AND ASSEMBLY	14
5.1	CHECKING THE MACHINE ON DELIVERY	14
5.2	ASSEMBLY SEQUENCE	16
CHAPTER 6	ADJUSTMENT, PREPARATION AND USE.....	25
6.1	INTRODUCTION	25
6.2	MOUNTING TO THE TRACTOR	25
6.3	CONNECTING THE CARDAN SHAFT	26
6.4	TRANSPORT BY ROAD	27
6.5	GENERAL INSTRUCTIONS FOR FIELD USE	28
6.6	GENERAL INSTRUCTIONS FOR USE	28
CHAPTER 7	MAINTENANCE	36
7.1	MAINTENANCE DIRECTIONS	36
7.2	REPAIR INSTRUCTIONS	37
7.3	LAYING UP FOR EXTENDED PERIODS	37
7.4	MAINTENANCE AND TESTING	38
7.5	MAINTENANCE POINTS	39
7.6	CARDAN SHAFT MAINTENANCE	40
7.7	NOISE AND VIBRATION	41
7.8	SCRAPPING THE MACHINE	41
CHAPTER 8	SPARE PARTS	42

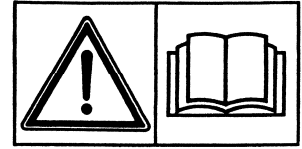

CHAPTER 1

GENERAL INTRODUCTION - WARRANTY

1.1 INTRODUCTION

The user of the lawn mower (later referred to as the "machine") is responsible for his own safety as well as that of the people in proximity of it.

It is therefore crucial that the user has detailed information on the use and maintenance of the machine and on how to connect it correctly to a tractor.

This machine can operate only through a Cardan shaft attached to the power takeoff of an agricultural tractor equipped with a draw-bar and a hydraulic system. This manual is intended both for the operator and those responsible for maintenance. Essential instructions and procedures to follow during use and maintenance of the machine are conveyed through drawings and text.

The user is responsible for ensuring that the machine is connected to the tractor and is operated in compliance with current legal provisions.

The machine must only be operated and maintained by persons who have read this manual. The manual should always be kept to hand. It is particularly important to read CHAPTER 3 on general safety instructions. These instructions must always be heeded.

If you are in any doubt, contact the Assistance Center or your nearest dealer.

1.2 WARRANTY

On delivery, check that the machine has not been damaged during transport and that all the attachments are present. Claims must be made in writing to the agent within 8 days of receipt.

The manufacturer warrants new machinery at the time of delivery to the original purchaser to be free from defects in material and workmanship if properly set up and operated in accordance with this Operator's Manual.

The manufacturer undertakes to repair or replace free of charge any defective part which should be returned by the purchaser (freight prepaid) and found to be defective by inspection authorized by The manufacturer during the warranty period.

This warranty will be valid for 12 (twelve) months from the delivery of goods to the original purchaser.

In case the customer is not in a position to return the defective part to the manufacturer, the manufacturer cannot be held responsible for any cost due for repair or replacement of any part of the machine, he will only supply the part(s) required for the repair and/or replacement.

The warranty is null and void when it is evident that the machine has been improperly used or repaired or however repaired without authorization.

The manufacturer undertakes no responsibility for any obligation or agreement reached by any employers, agents or dealers, which are not in compliance with the above warranty. The manufacturer cannot be held responsible for the consequent damages. This warranty substitutes any other warranty, express or implied, and any other manufacturer's obligation.

NOTE:

ALL WARRANTY WORK OR REPAIRS MUST BE APPROVED BY THE MANUFACTURER BEFORE WORK BEGIN.
ANY WORK OR REPAIRS MADE BEFORE APPROVAL MAY NOT BE COVERED UNDER WARRANTY.
PLEASE NOTIFY YOUR SALES & SERVICE DEPARTMENT OF THIS POLICY.

CHAPTER 2

GUIDE TO THE SIGNS AND SYMBOLS USED IN THIS MANUAL AND THEIR LOCATION ON THE MACHINE

2.1 SIGNS AND SYMBOLS

These signs and symbols give information to the operator on how to make the best use of the machine so as to prolong life, avoid damage, optimize work and, above all, to avoid injury to the operator and anyone within range of the machine.

2.2 WARNING SIGNS

1. Before beginning operations, read the instruction manual carefully.

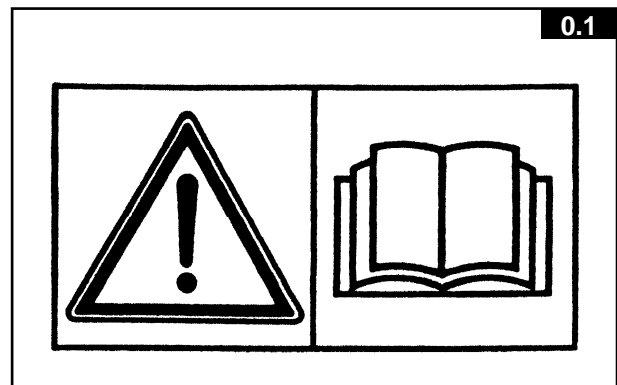

2. Prior to any maintenance work, adjustments or repairs, stop the machine, set it on the ground, turn off tractor and apply parking brake. Remove key from ignition and consult the instructions and maintenance manual.

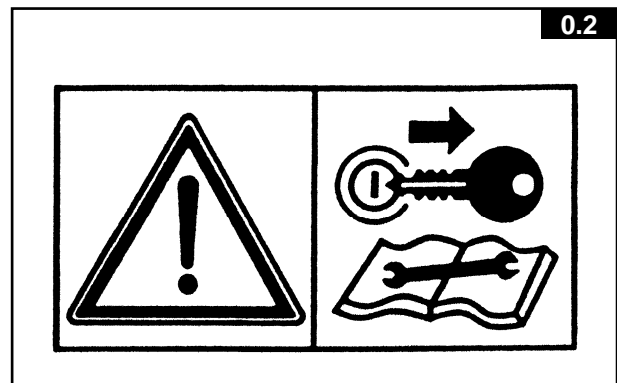

3. This is a warning to use proper accident protection when carrying out maintenance and repairs

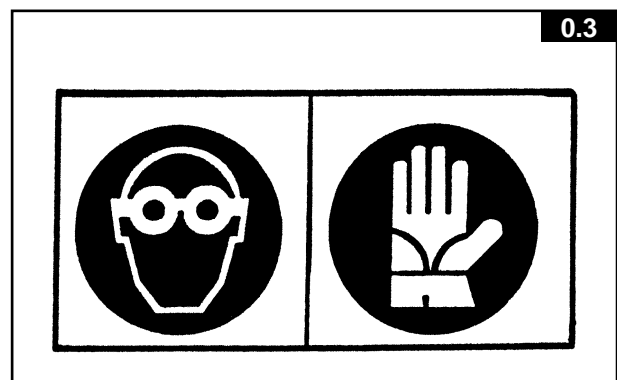

4. Warns the danger of cutting blade

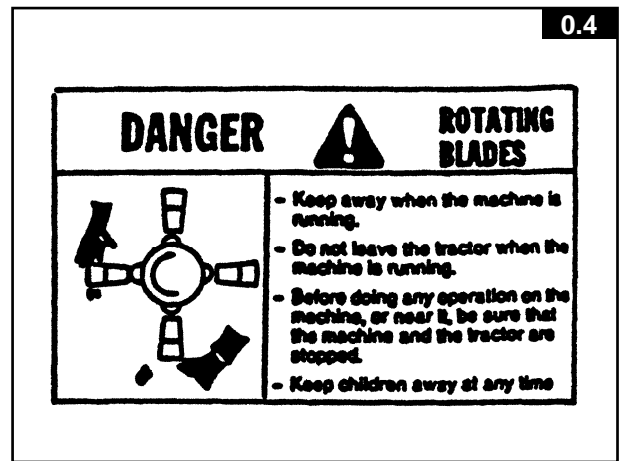

5. This sign is a reminder to check the oil level.

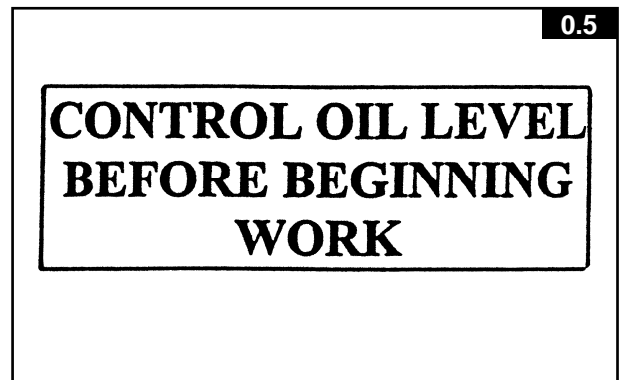

2.3 DANGER SIGNS

6. Indicates an impending dangerous situation which, if not avoided, will cause death or severe personal injury.



7. General danger

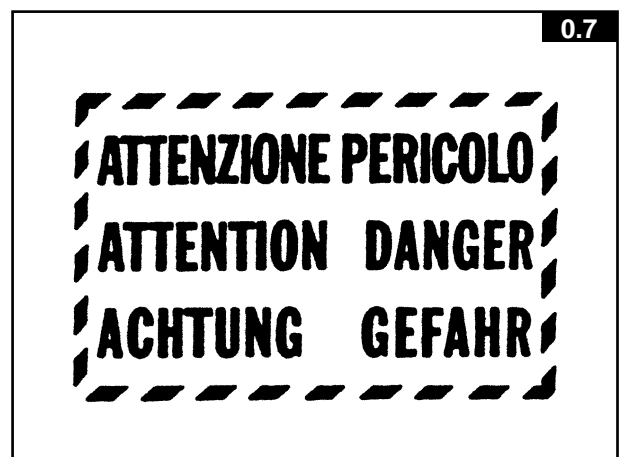

8. This indicates a potential danger which, if not avoided, could cause serious personal injury. It also indicates danger when removing protective guards.



9. Indicates a potentially dangerous situation which, if not avoided, can provoke less severe or minor injuries.



10. Risk of possible ejection of blunt objects. Keep a safe distance from the machine.

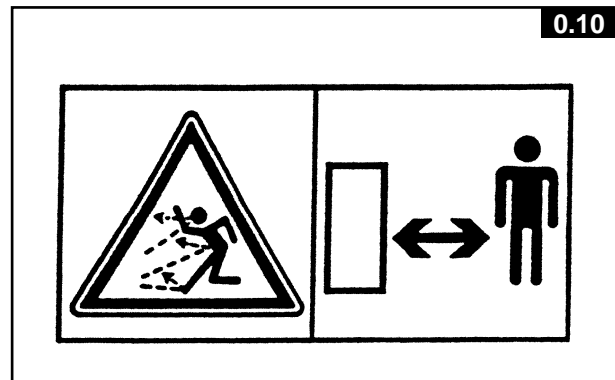

11. This indicates the risk of cutting one's foot. Keep at a safe distance.

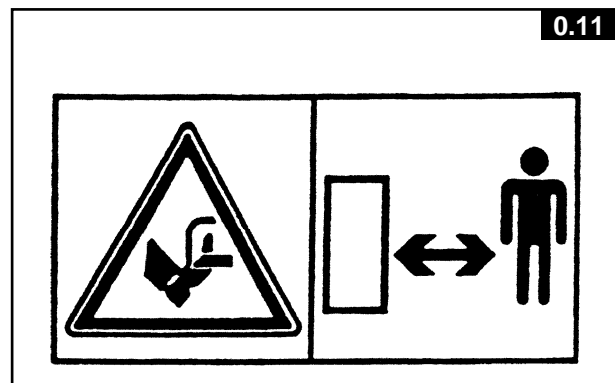

12. This indicates the risk of cutting one's hand. Keep at a safe distance.

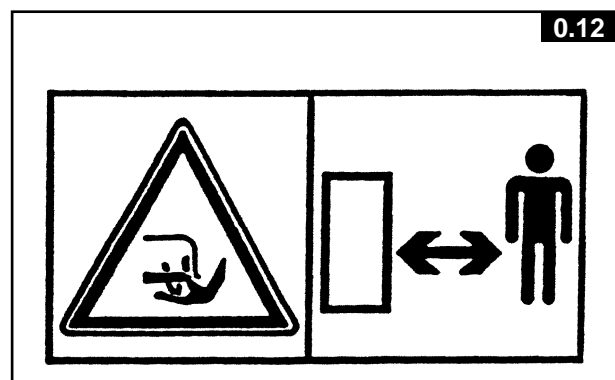

13. Indicates that it is dangerous to touch the Cardan shaft. For all other information regarding the Cardan shaft, see the use-and-maintenance booklet specifically for the Cardan shaft which, together with this manual, makes up the documentation on safety, use and maintenance of the machine.



14. Indicates danger caused by accidental fall of suspended arms. Keep safe distance

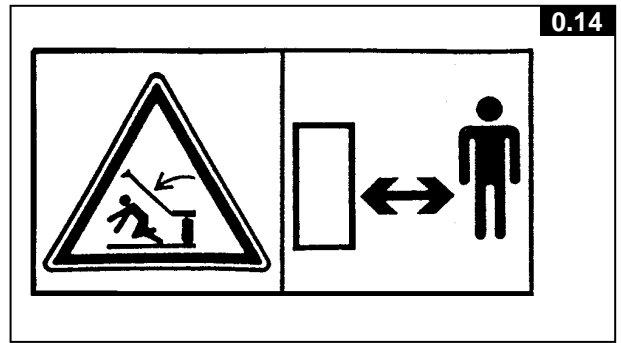

2.4 INDICATION SIGNS

15. This indicates the oil level

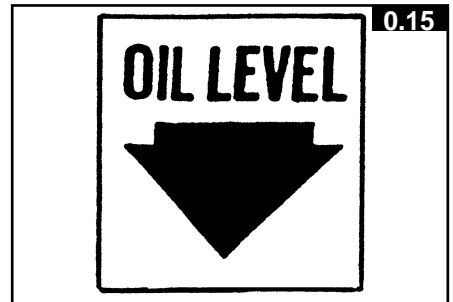

16. Indicates a greasing point.



17. Shows the direction of rotation of the power takeoff and the maximum number of revolutions.

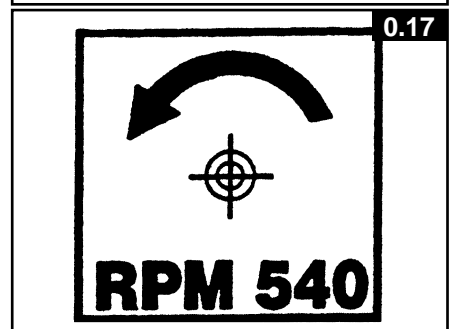

NOTE: All the signs and symbols so far shown appear in the manual. Some of these are also on the machine: for their location, the diagram on page 8.

2.5 LOCATION OF SIGNS AND SYMBOLS ON THE MACHINE

- Machine casing

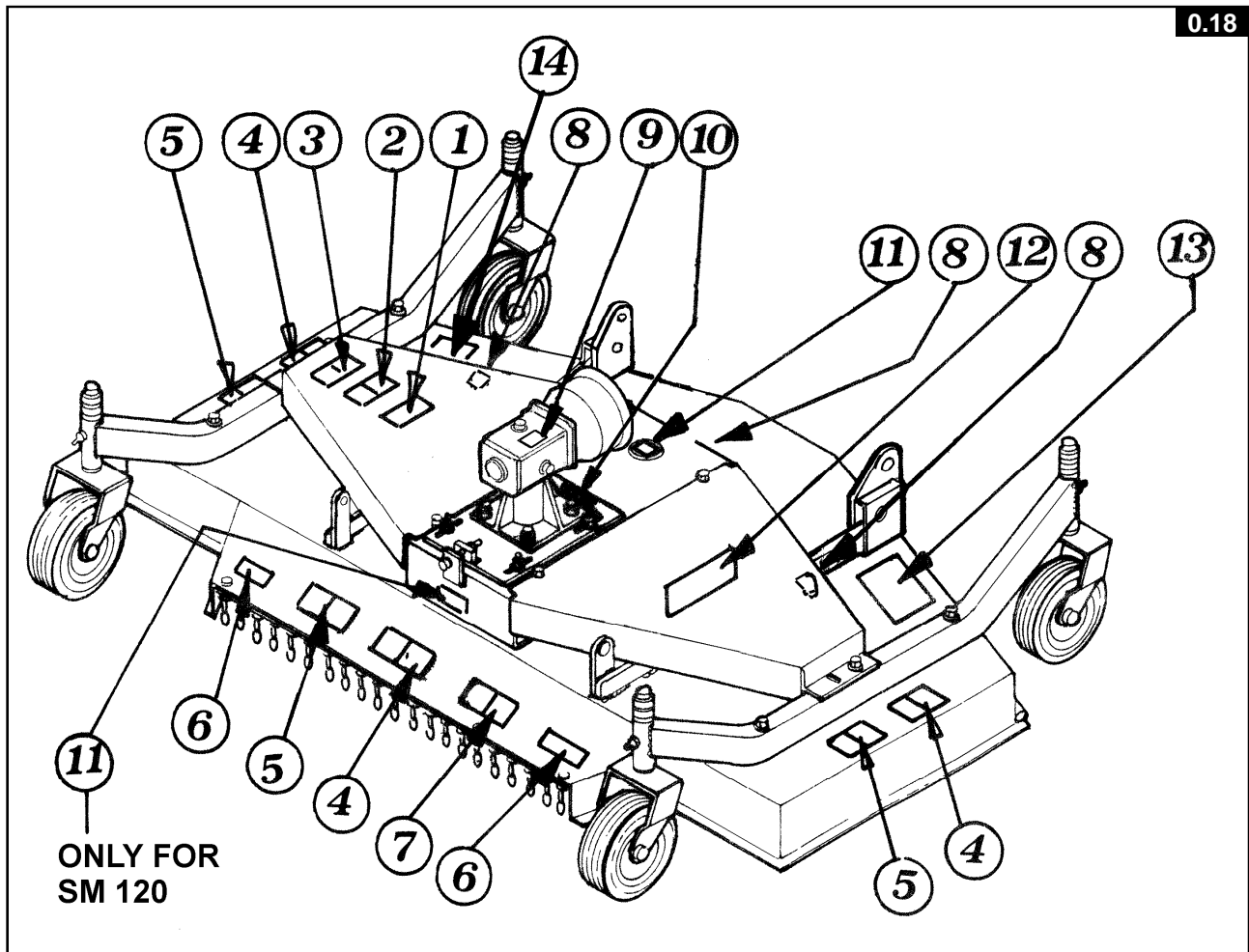

- 1) Serial number plate
- 2) See point 1 page 4
- 3) See point 2 page 4
- 4) See point 11 page 6
- 5) See point 12 page 6
- 6) See point 7 page 5
- 7) See point 10 page 6
- 8) See point 16 page 7
- 9) See point 15 page 7
- 10) See point 5 page 5
- 11) See point 17 page 7
- 12) Manufacturer decal
- 13) See point 4 page 5
- 14) Decal with model of machine

- Machine

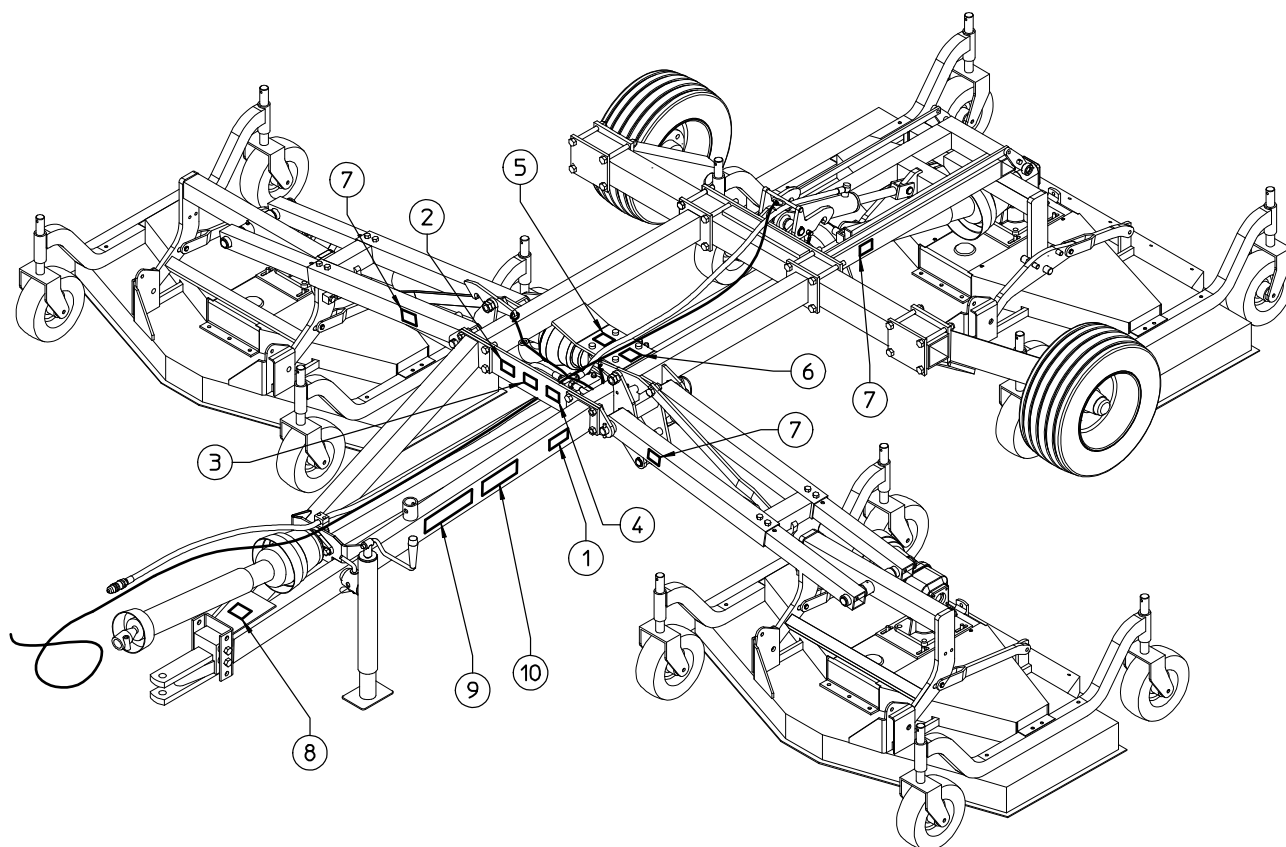

- 1) Serial number plate
- 2) See point 1 page 3
- 3) See point 2 page 3
- 4) See point 3 page 3
- 5) See point 5 page 4
- 6) See point 7 page 4
- 7) See point 14 page 6
- 8) See point 17 page 6
- 9) Manufacturer decal
- 10) Decal with model of machine

CHAPTER 3

GENERAL SUMMARY OF SAFETY AND ACCIDENT - PREVENTION INSTRUCTIONS

3.1 GENERAL SUMMARY OF SAFETY AND ACCIDENT-PREVENTION INSTRUCTIONS

Read all the directions carefully before using the machine. When in doubt, seek advice from the manufacturers.

The manufacturing company declines all responsibility for non-compliance with the following safety and accident-prevention instructions.

- 1-** Pay attention to the danger signs and symbols in this manual and on the machine.
- 2-** Do not touch moving parts.
- 3-** All work on the machine (including adjustments) must always be carried out with the tractor immobilized and the engine switched off.
- 4-** On no account may persons or animals be carried on the machine.
- 5-** Driving the tractor with the machine connected is absolutely forbidden to persons lacking suitable experience, or who are in poor health, or who do not have a suitable driving license.
- 6-** All accident-prevention measures recommended in this manual should be scrupulously observed.
- 7-** Connecting the machine to the tractor creates a different weight distribution on the axles and so it is essential to ensure that the tractor-machine combination is stable in all anticipated working conditions. It is therefore necessary to have exact instructions from the tractor manufacturers. If such instructions are not available, suitable tests should be conducted in safe conditions in order to assess stability.
- 8-** Once the machine is connected, it can only be controlled through a Cardan shaft complete with the required overload protection and guard secured with the appropriate small chains. Be aware of the rotational direction of the Cardan shaft.
- 9-** Before operating the tractor and machine, check that all transport and operational safety devices are complete and working.
- 10-** When driving on public roads, you should comply with the Highway Code regulations for the country concerned.
- 11-** Do not exceed the tractor axle maximum weight and the total mobile weight. Heed transport regulations.
- 12-** Before starting work, familiarize yourself with the control devices and how they work.
- 13-** Wear suitable clothes. Do not wear clothing which is loose or which could become entangled in rotating or moving parts.
- 14-** Connect the machine to a suitably powerful tractor by using an appropriate lifting unit and in accordance with instructions.
- 15-** Take maximum care when connecting and disconnecting the machine to and from the tractor.
- 16-** The machine and any road transport attachments must bear the appropriate signs and symbols and have suitable protection.
- 17-** Never leave the driving seat when the tractor is running.
- 18-** It is extremely important to appreciate that road holding, steering and braking may be significantly affected with the machine attached.

- 19-**When turning corners with the machine attached, be aware of the fact that the centrifugal force will alter due to the change in the center of gravity.
- 20-**Before engaging the power takeoff check the preset revolution speed. Do not change speed from 540 rpm to 1000 rpm.
- 21-**Under no circumstances should anybody stand near the machine or any moving parts. It is the duty of the operator to ensure that this requirement is respected.
- 22-**Before leaving the tractor, lower the machine with the lifting unit, stop the engine, apply the parking brake and remove the ignition key from the instrument panel.

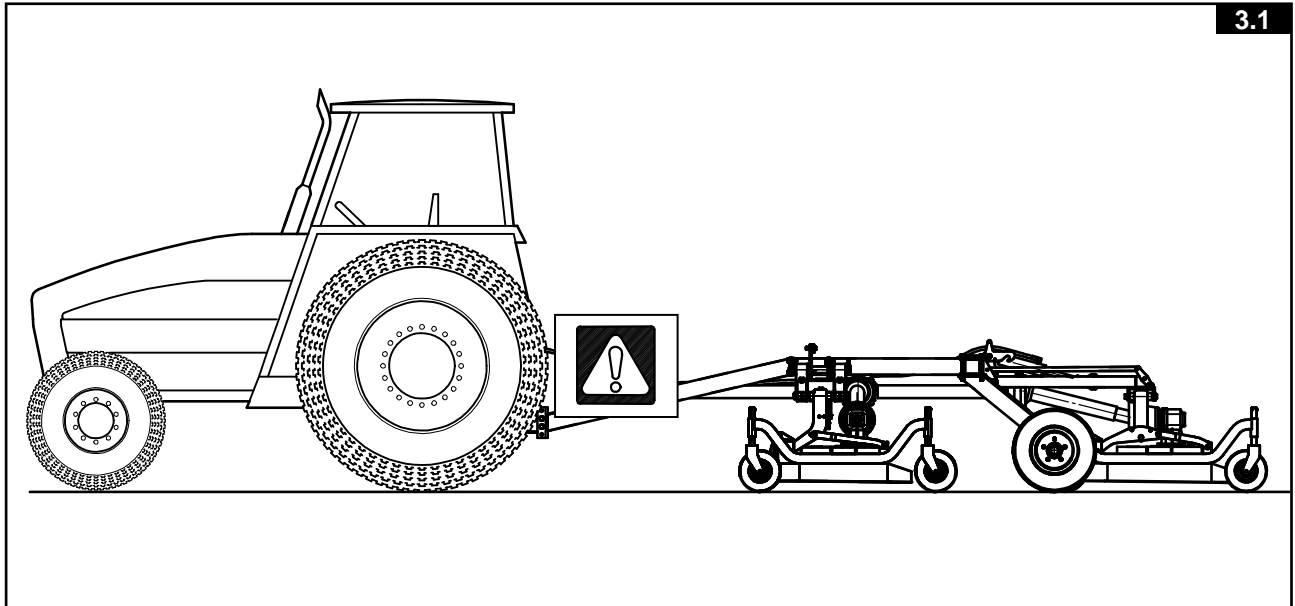

- 23-**Under no circumstances should anybody go between the tractor and the machine (Fig. 3.1) when the engine is running and the Cardan shaft is engaged, especially without first having applied the parking brake and placed chocks against the wheels.
- 24-**Before connecting or disconnecting the machine to or from the 3-point linkage, put the lifting unit lever into the locked position.
- 25-**The connection pins on the machine must match the connection sockets on the lifting unit.
- 26-**During transport, secure the lateral lifting arms with the appropriate chains and tighteners.
- 27-**When the machine is raised during road transport, put the tractor's hydraulic lifter lever into the locked position.
- 28-**Only use the Cardan shaft provided by the manufacturer and, in case of replacement, substitute it with one having the same characteristics.
- 29-**Regularly check all protection on the Cardan shaft. This should always be in excellent condition and securely fixed.
- 30-**It is important to ensure that the protection on the Cardan shaft is complete.
- 31-**Connection and disconnection of the Cardan shaft must be carried out with the engine switched off.
- 32-**Pay particular attention to the correct connection and safety of the Cardan shaft and the power takeoffs on the machine and the tractor.
- 33-**Prevent the cardan shaft protection from rotating using the chains supplied.
- 34-**Before engaging the power takeoff, make sure that there are no people or animals in the vicinity and that

the selected engine speed corresponds to that permitted. Never go above the maximum permitted.

- 35-**Do not engage the power takeoff when the engine is not running.
- 36-**Always disengage the power takeoff when the Cardan shaft is at too wide an angle (it should never be more than 35° Fig. 3.2) and when it is not in use.
- 37-**Only clean and grease the Cardan shaft when the power takeoff is disengaged, the engine is off, the parking brake is applied and the ignition key is removed.
- 38-**On disconnecting the Cardan shaft, replace the protective hood on the power takeoff shaft.
- 39-**Prolonged use of the machine can cause the drive boxes to become hot. To avoid any risk of getting burnt, avoid touching these areas both during use and some time afterwards.
- 40-**Periodically check screws and nuts for tightness and grip. Tighten if necessary.
- 41-**When carrying out maintenance work or replacing the blades, raise the machine and rest on adequate supports.
- 42-**Use the quantities of grease and oil advised.
- 43-**Spare parts must meet the requirements as defined by the manufacturer. Use only original spare parts.
- 44-**Safety decals must always be clearly visible. They must be kept clean and replaced if they become too illegible (they can be ordered from the agent if necessary).
- 45-**The instruction booklet must be available for the lifetime of the machine.

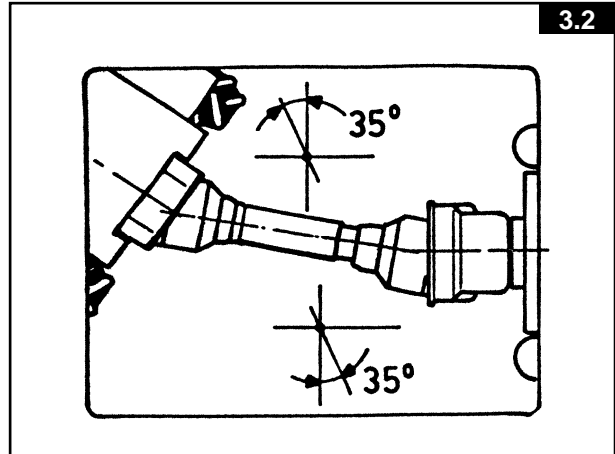

CHAPTER 4

PRODUCT IDENTIFICATION

4.1 TECHNICAL DATA

The machine consists of three mowers mounted on a frame with lift arms to reduce overall dimensions during transport. The oscillating mower arms enable the machine to adapt to ground conditions during work. The 3600 version consists of two SM/120 and one SM/150, the 4500 model has two SM/150 and one SM/180, and the 5200 version has two SM/180 and one SM/230. The largest cowl is mounted at the back in all models. The technical specifications for each model are given in the table.

Model	Approximate Weight Lbs / kg	RPM of gearbox	Cutting width feet	Blade tip speed m/s	No. Blades	Cutting height		Power required HP/kW
						mm	inches	
SM/3600	2600 / 1180	540*	12	70.5	9	20 – 125	3/4" – 5"	30/22
SM/4500	2800 / 1270	540*	15	70.5	9	20 – 125	3/4" – 5"	35/26
SM/5200	3100 / 1410	540*	17	70.5	11	20 – 125	3/4" - 5"	40/30

4.2 MAIN MACHINE PARTS

ITEM	Description	ITEM	Description
1	Machine casing	9	Gearbox
2	Drawbar	10	Wheel
3	Parking stand	11	Wheel
4	Frame	12	Cylinder
5	Bracket	13	Cardan shaft
6	Rear arm	14	Rope
7	Lateral arm	15	Hose
8	Axles		Name plate

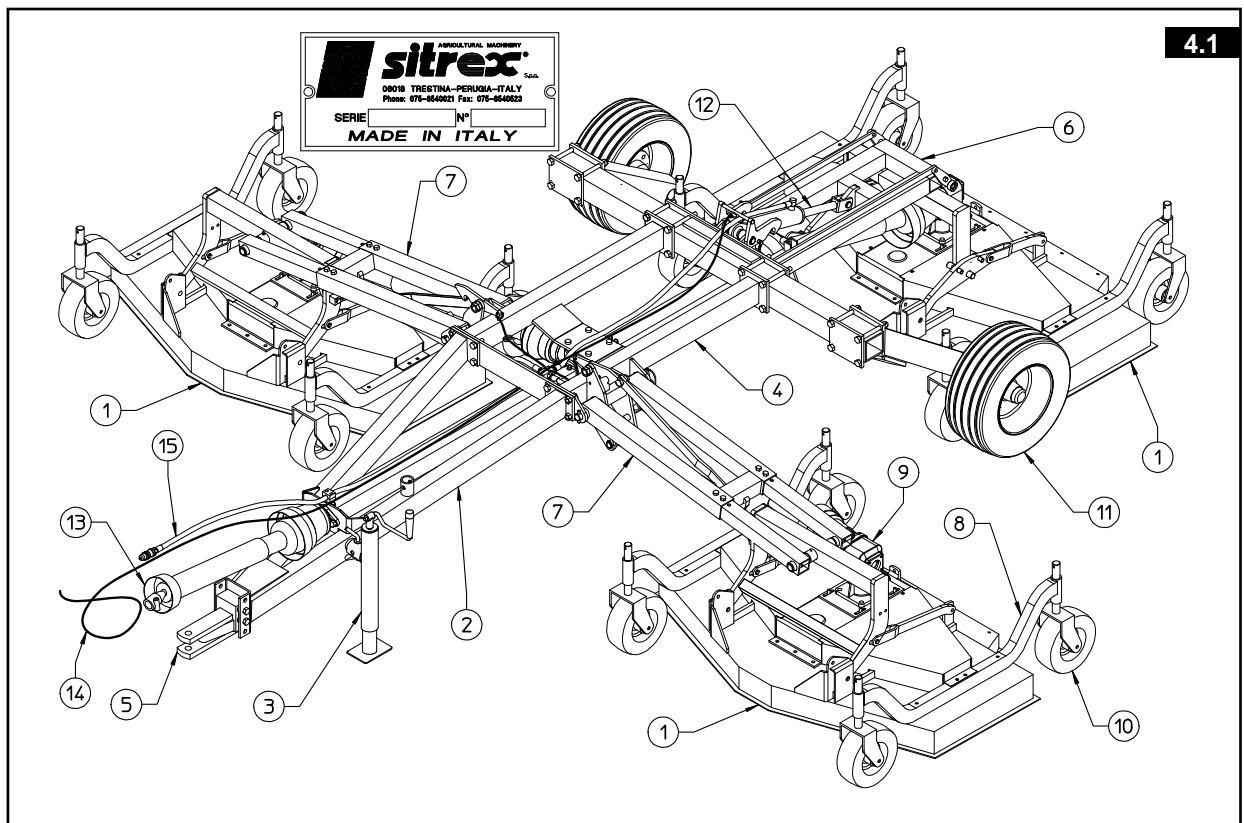

CHAPTER 5

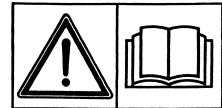

DELIVERY AND ASSEMBLY

5.1 CHECKING THE MACHINE ON DELIVERY

All parts carefully checked before dispatch or delivery.



On receiving the machine, ensure that it

not been damaged during transport. If damage has occurred, contact the dealer concerned.

How the machine is lifted will depend on the model and the type of packing. Details are given below. The packing can vary from country to country depending on transport requirements.

Lift the machine using a forklift truck, crane or other suitable equipment of sufficient capacity after first checking the weight of the configurations in the table given below.

Check the stability and positioning of the load on the forklift truck forks or crane hook.

Keep the load as low as possible during movement for maximum stability and to ensure that the operator has maximum visibility.

If a forklift truck is used, ensure that the forks are positioned as wide apart as possible.

The manufacturer packages the machines according to the following models:

Fig. 5.1: represents the standard packaging for the lawn mower with rear grass ejector.

Fig. 5.2: represents the packaging for cart.

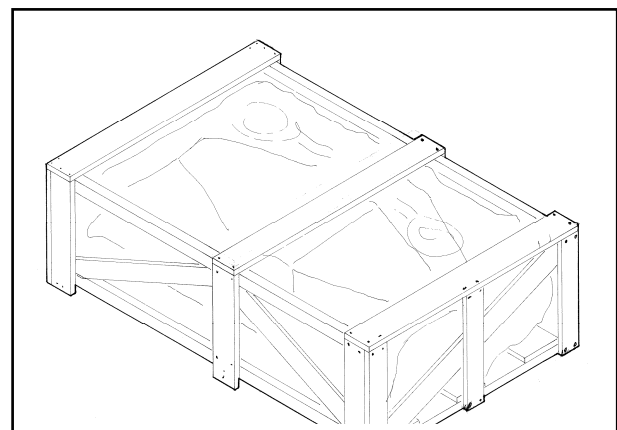
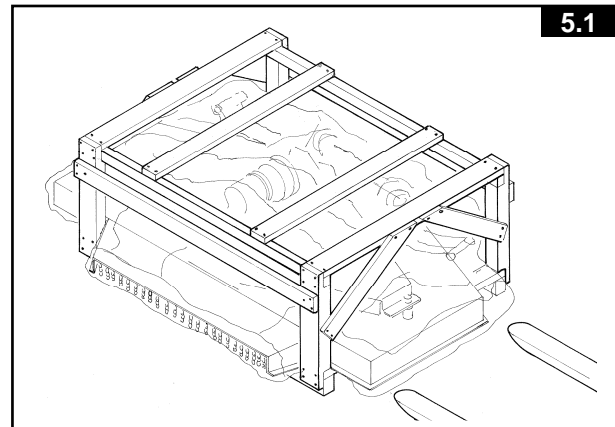

Packaging consists of a crate containing the load-bearing frame, plus three pallets for the three mowers. Alternatively, the three mowers can be packed in a single crate. The following table gives the weight

pallet for each mower, the weight of the frame (the machine without the mowers) and the gross weight of the crate with the frame. The final column shows the weight of the three mowers when packed together in a single crate.

PACKAGING TYPE	MACHINE WEIGHT KG-LBS						
	120	150	180	230	Machine	Cart Fig. 5.12	Single crate
Fig. 5.1	178-390	208-455	239-525	310 – 685	SM/3600		
					SM/4500		
					SM/5200		
* Weight of crated machine							
** Net weight of one machine each model							



Notes:

- 1) Slightly different packaging from those represented may occasionally be used, depending on the methods of transport or handling.
- 2) The packing consists mainly of wood, which should be disposed of according to the laws in force in the country where the machine is used. The plastic film should also be disposed of according to the laws in force in the country where the machine is used.
- 3) When storing, it is permissible to stack 2-3 crates on top of each other. Make sure that they are perfectly aligned vertically.
- 4) In the case of further transportation, make sure the machine is well secure on the transport means.

5.2 ASSEMBLY SEQUENCE

Assembly is highly dangerous and must be carried out in strict accordance with the following instructions. We recommend that qualified personnel perform assembly. We also recommend that assembly be carried out in a flat, open area with no people (particularly children) nearby who could be severely injured if they were to touch or move any parts of the machine.

5.2.1

Keep the main casing 1 approx. 400/600 mm above the ground, resting it on suitable supports or on the forks of a forklift.

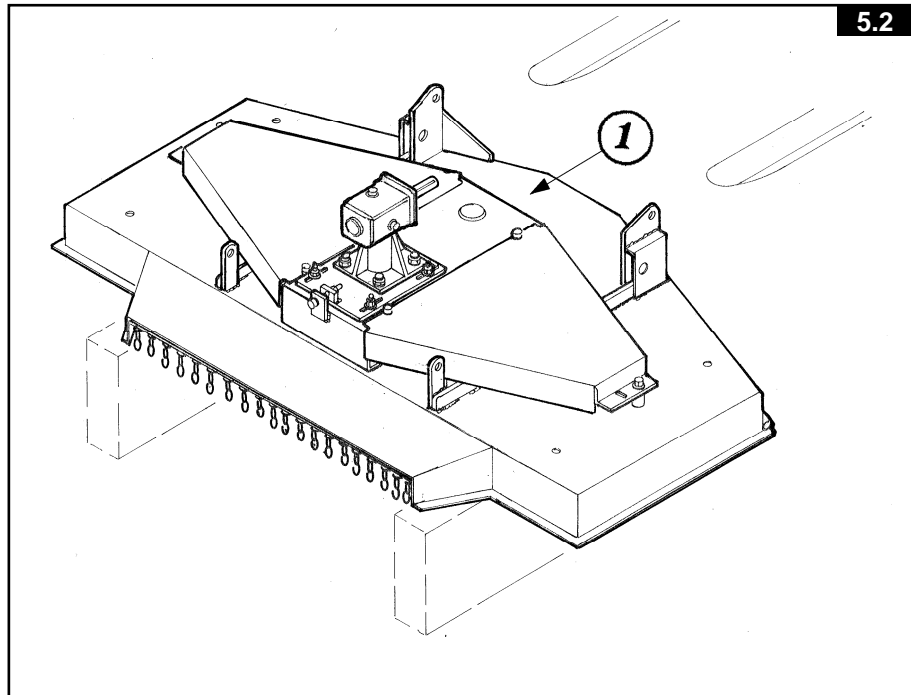

5.2.2

Fit the protective cap 2 to the correct mounting on the gearbox 1 using the flat washers 3 and the screws 4.

For this step you will use:

Item 2: n°2 - flat washers D 8.5 (D 21/64)

Item 3: n° 2- screws M8x16 (5/16x5/8)

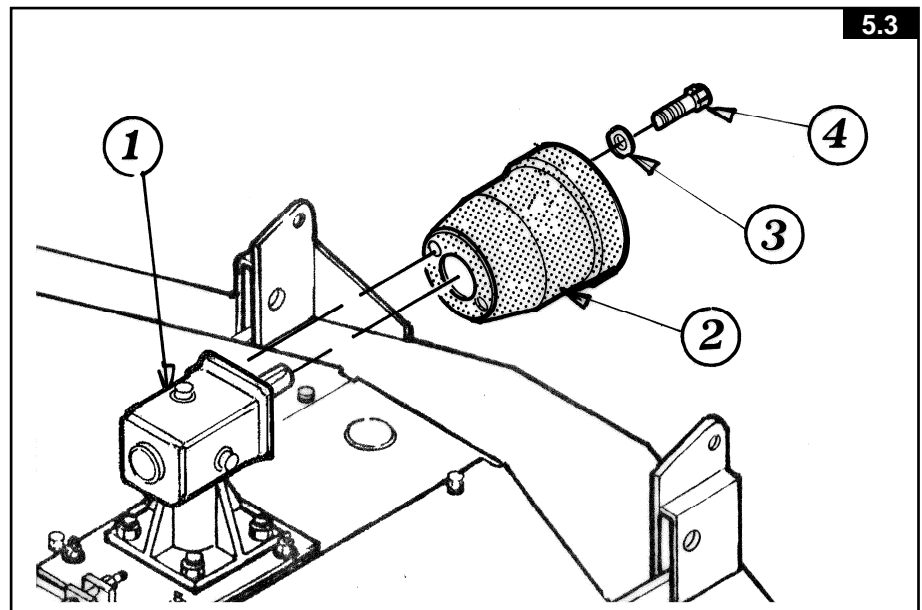

5.2.3

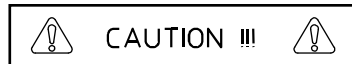

Fit the axles 2 to the main casing 1. To do this you must initially remove the central screws 6 and the washers 4 & 5, which attach the protective guard 3 to the main casing 1. Then fix the axles 2 to their correct mountings on the main casing 1 using the flat washers 4, the notched washers 5 and the screws 6. For this step you will use:

Item 4: n° 6 - flat washers D 15 (D 19/32)

Item 5: n° 6 - notched washers D 15 (19/32)

Item 6: n° 6 - screws M14x95 (D 19/32x3"3/4)

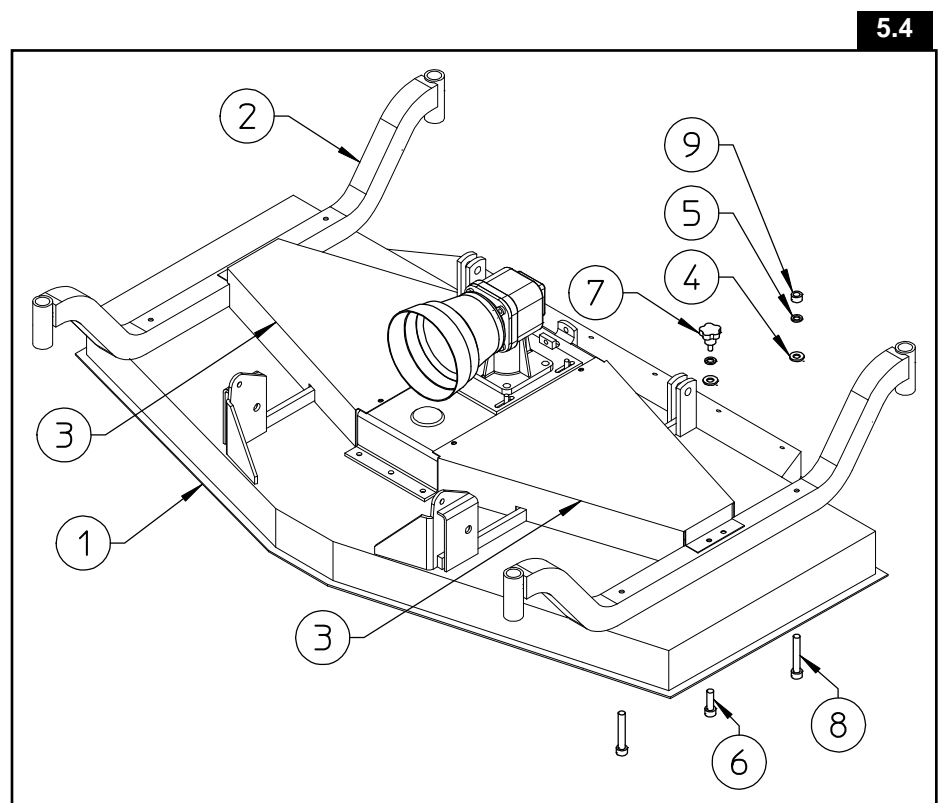

Warning: The gear boxes have already been assembled on the cowls. The side cowls contain the lateral power take-off (on the right or left-hand side according to which side it has been assembled on), whereas the box on the rear cowl is assembled as shown in the picture. The side cowls have normal axles (as shown in the picture), whereas the rear cowl axle uses bushings with hexagonal holes on the front of the machine. The reason for this is that the wheel must be firmly held facing forwards in order to guarantee the machine better forward movement. When the rear cowl is an SM/150, the axles are straight, whereas the axles for the SM/180 and SM/230 converge towards the centre of the machine in order to decrease their overall dimensions.

5.2.4



Fit the wheel units 2 to their correct mountings on the axles 1. Connect the shim 3 (D 30/40x12 - D 1"3/16x1"9/16x1/2") to the axle on wheel unit 2. The shim is selected according to the required cutting height (see page 31), therefore what we are describing is an example.

Next, the wheel unit 2, onto which the shim 3 has been secured, must be connected to the correct seat on the axles 1. Now fasten onto the axle of the wheel unit 2 the shims:

item 4 (D 30/40x32 - D 1"3/16x1"9/16x1x1/4)

item 5 (D 30/40x25 - D 1"3/16x1"9/16x1") n°3 pz

item 6 (D 30/40x6 - D 1"3/16x1"9/16x1/4)

item 7 (D 30/40x2 - D 1"3/16x1"9/16x5/64).

At this stage secure everything with the split pins 8. Fit the grease nipples 9 to the correct positions on the axles 1.

For this step you will use:

Item 8: n°4 - split pins

D 8 (5/16)

Item 9: n°4 - grease nipples

M6 (15/64)

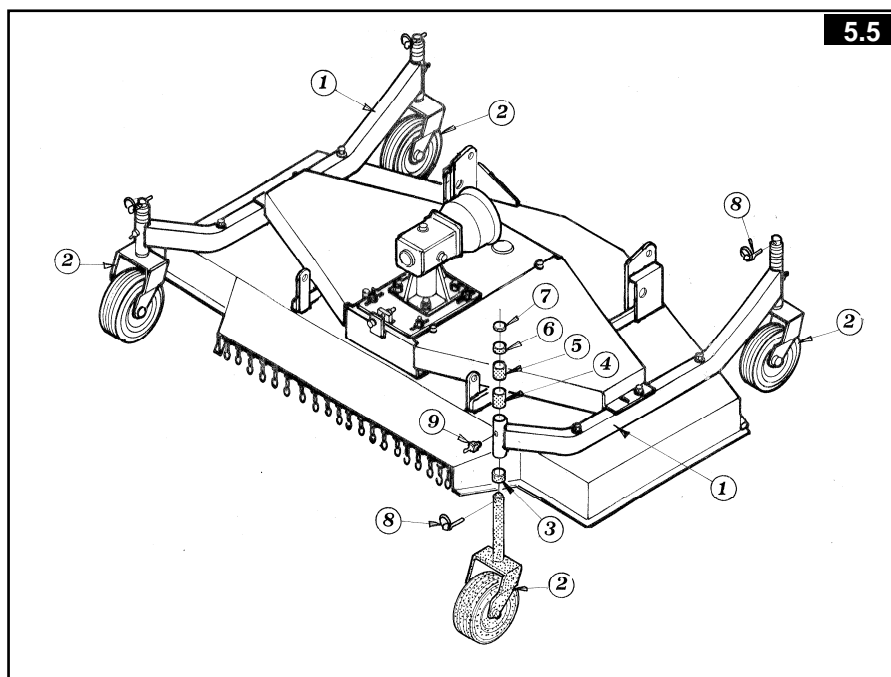

Item 9: n°4 - grease nipples
M6 (15/64)

For the rear mower, repeat the assembly instructions given above but assemble the wheel clamp with the hexagonal pintle on the front part. Assemble the bushings with an enlarged hole on to the pintle.

5.2.5

Use the screws 3 (M16x45) and the nuts 4 (M16) to fasten the draw-bar 1 to the main frame 2. The screws must be inserted as shown in the diagram.

Use the screws 6 (M16x140) and the nuts 4 (M16) to fasten the rear crosspiece 9 to the main frame with plate 10.

Use the same type of screws to assemble the wheel arms.

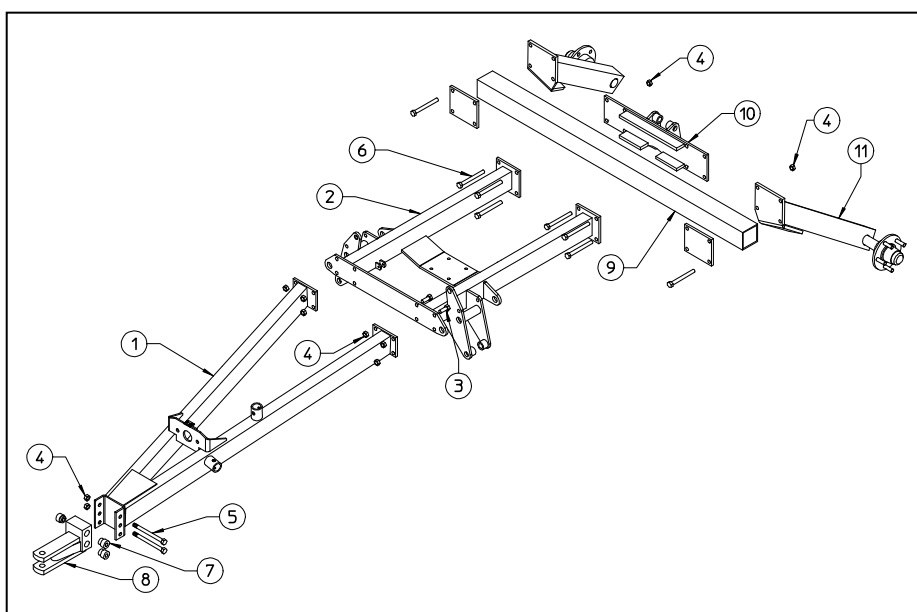

5.2.6 Use the cap nuts (M16x1.5) to fasten the wheels to the frame. Assemble the support foot and use the machine pin to fasten into position. The machine is now stable and can be rested on a firm, flat surface.

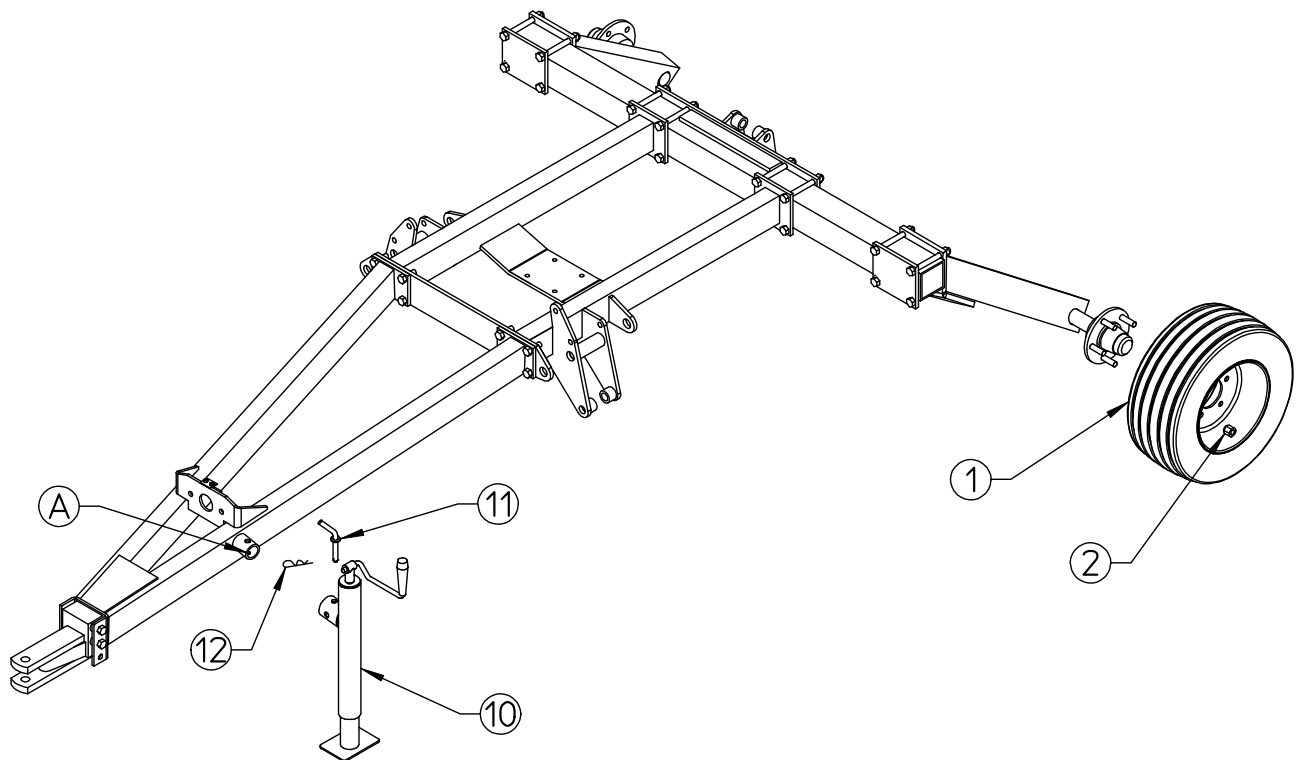

5.2.7 Mount the entire drive gear on the frame according to the diagram and assemble the short shields (20) on the box. After having fastened the shafts with the joint 83 and 22 into position by means of screw 84 / 22 and nut 51 / 15, protect them with the casings 15 and 23. The rear support plate 24 is fastened to the rear plate by means of a 30mm diameter pin holding the articulated rear arm, as well as by the screws 25. The screws should be tightened only after the arm has been assembled and not when the plate is put into position.

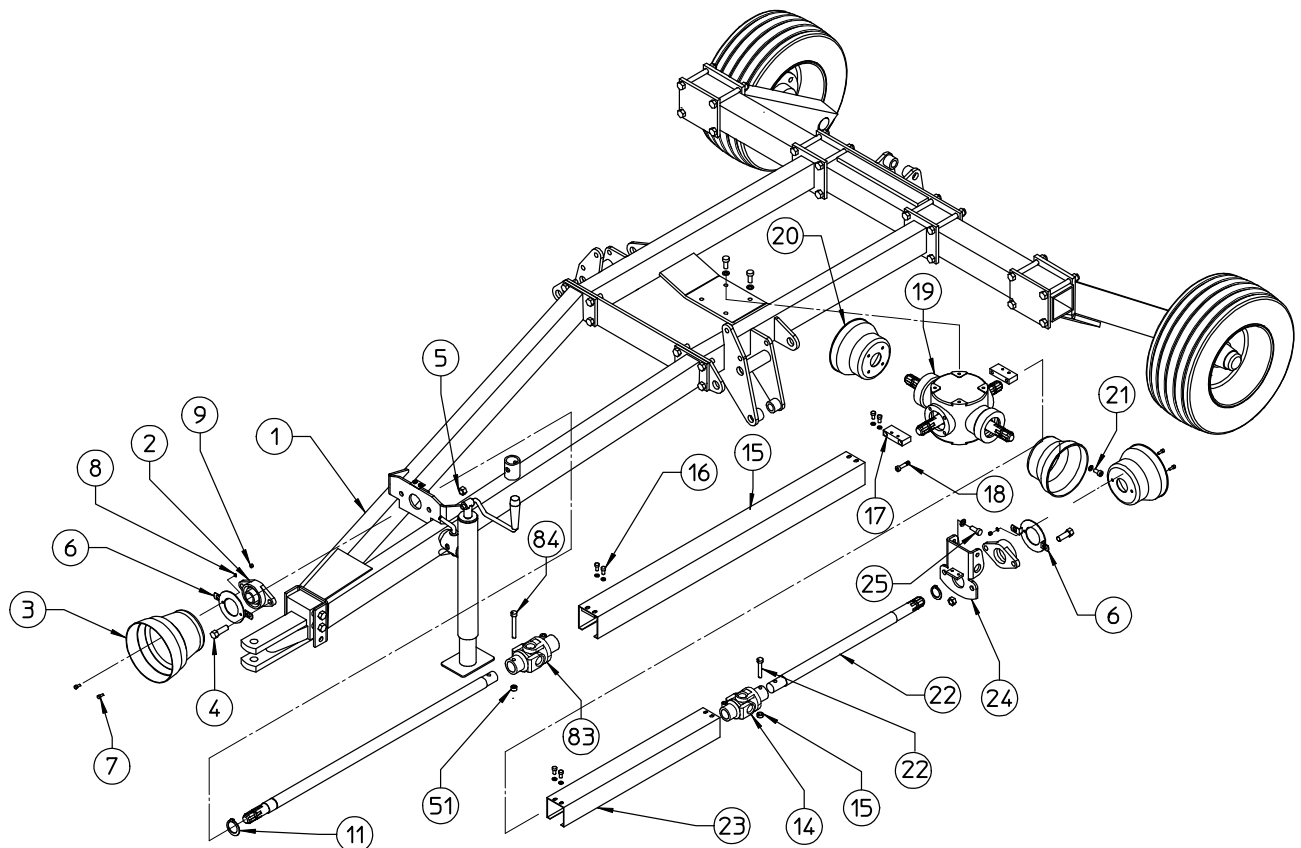

5.2.8 Use pin 3 inserted from behind to fasten the side arm to the frame, as shown in the diagram. Then insert the removable arms and fasten them into position with the screws 6 in the centre hole, for SM/3600 mounting in the last hole. Assemble the engine mounting 10 on the arm and place the distance washers 12 as shown in the diagram. During assembly operations make sure that the bushings 2 and 11 are already assembled in their respective housings. See spare parts for SM/3600.

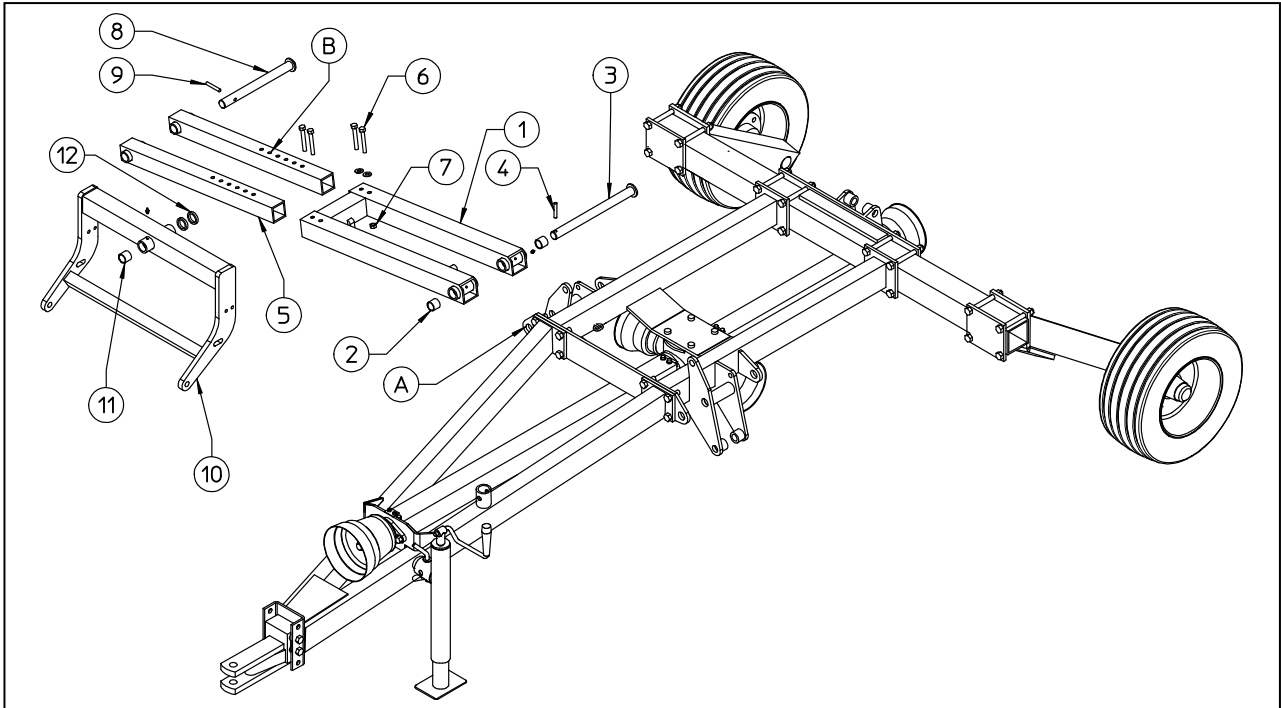

5.2.9 Repeat the procedure on the left-hand side of the machine.

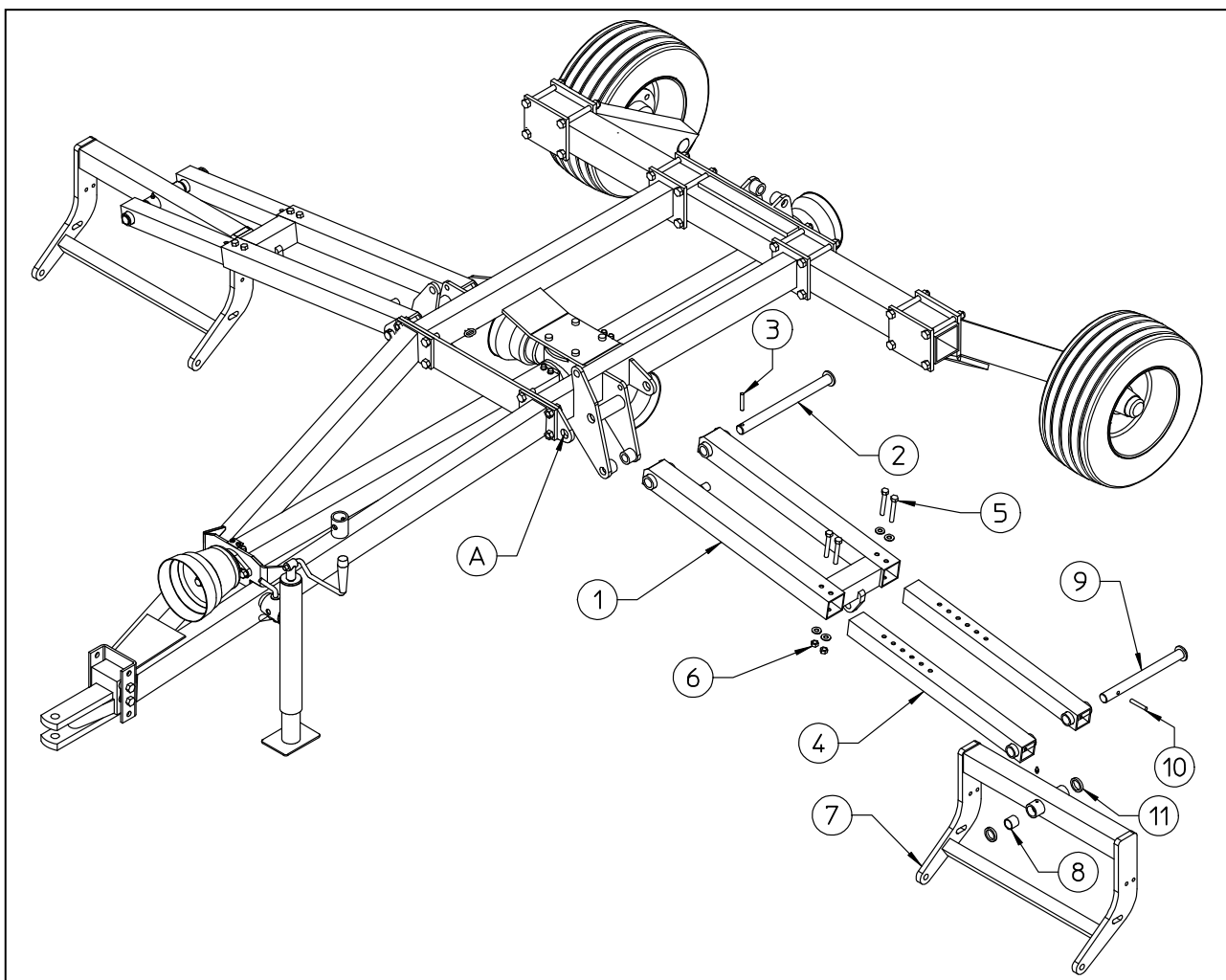

5.2.10 Use pin 2 to fasten the rear arm 1. This pin is inserted into the drive gear support plate, which can now be fastened into position. When the nuts are tightened, make sure that the shaft can rotate easily. Assemble frame 4 on the arm together with the oscillation control system, consisting of the tie rod 9, the connecting rod 10 and the small wheel 11.

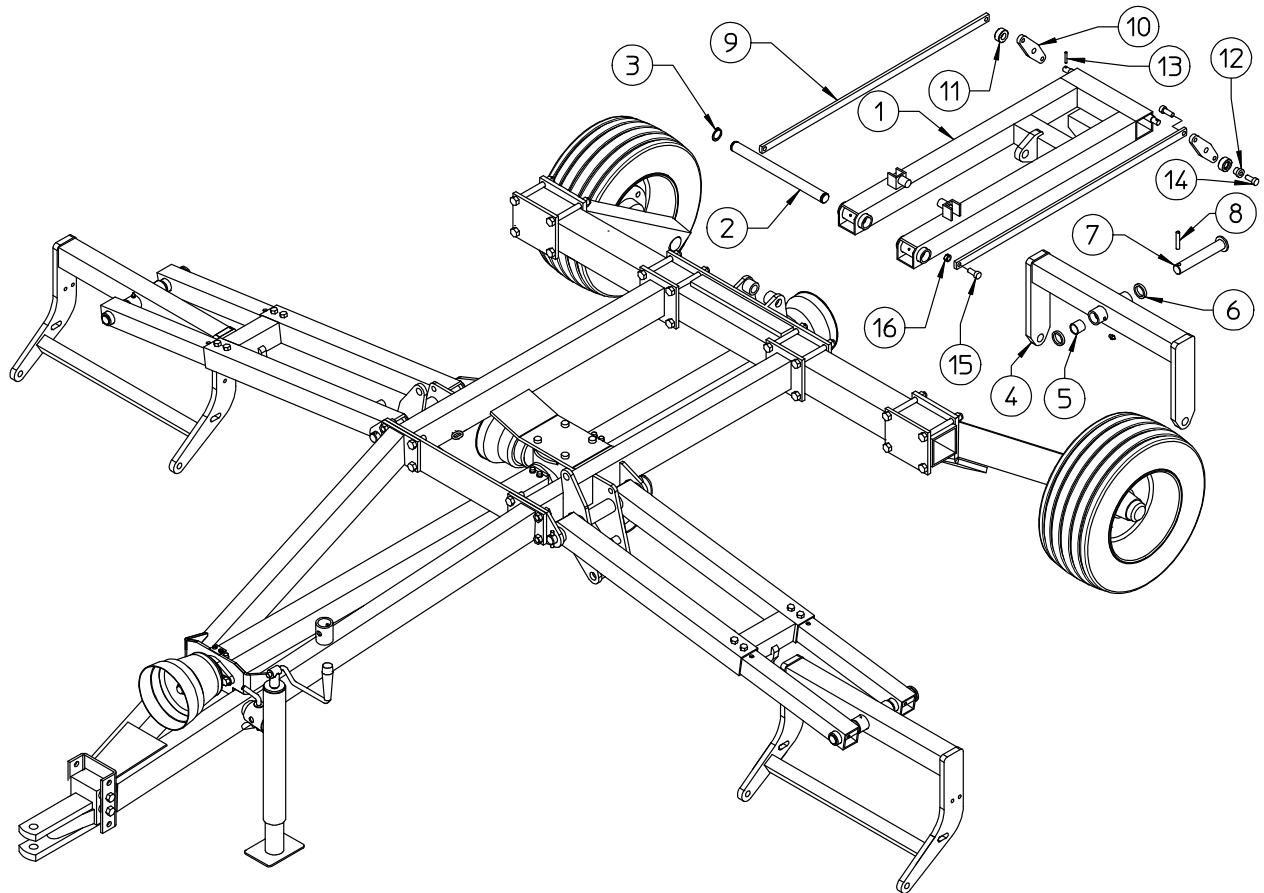

5.2.11 Assemble the tie rod and the hook, which blocks movement during transport, on to the side arms. The tie rods 1 and 3 must be assembled using their medium length. Also assemble the pins and the load spring for hook 9; pin 13 must be fastened so that it also acts as a rabbit for the hook

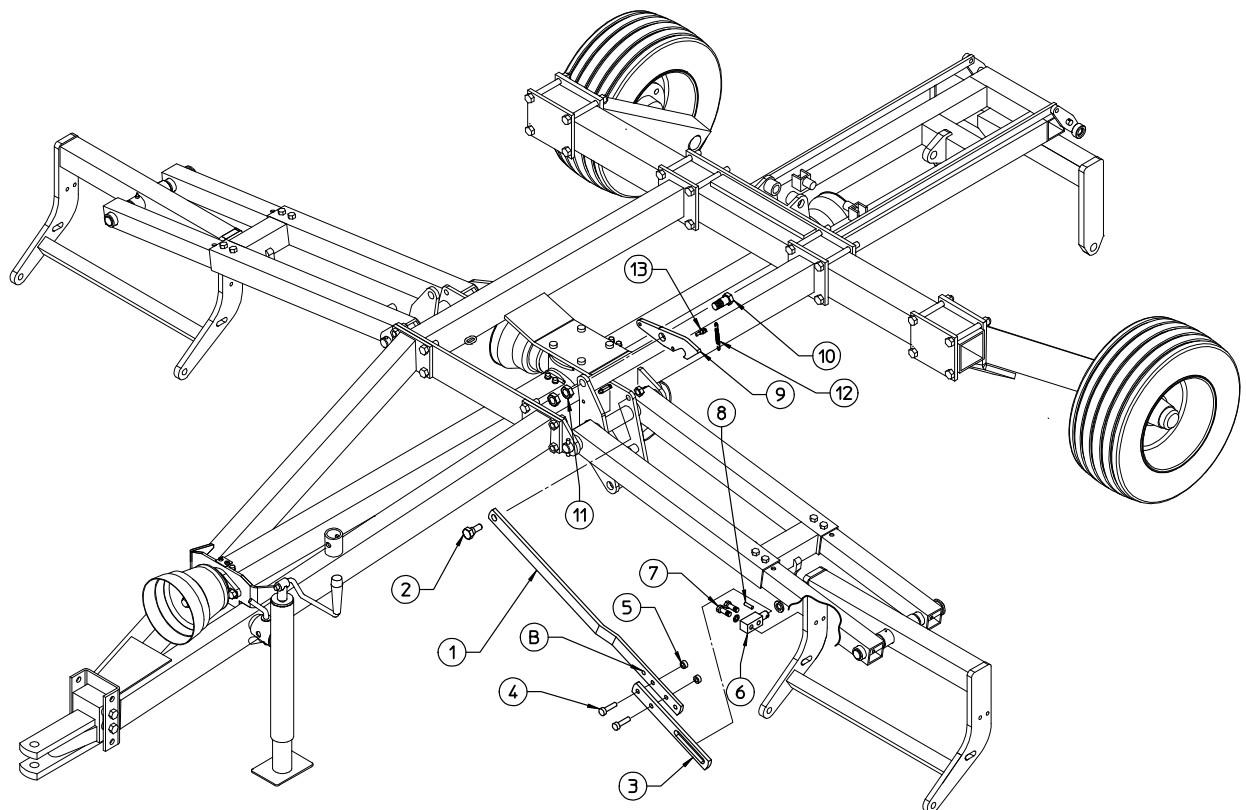

5.2.12 Assemble the cylinders and the oleo-dynamic system as shown. When using for the first time, make sure there are no oil leaks. If there should be any, tighten the pipe fittings.

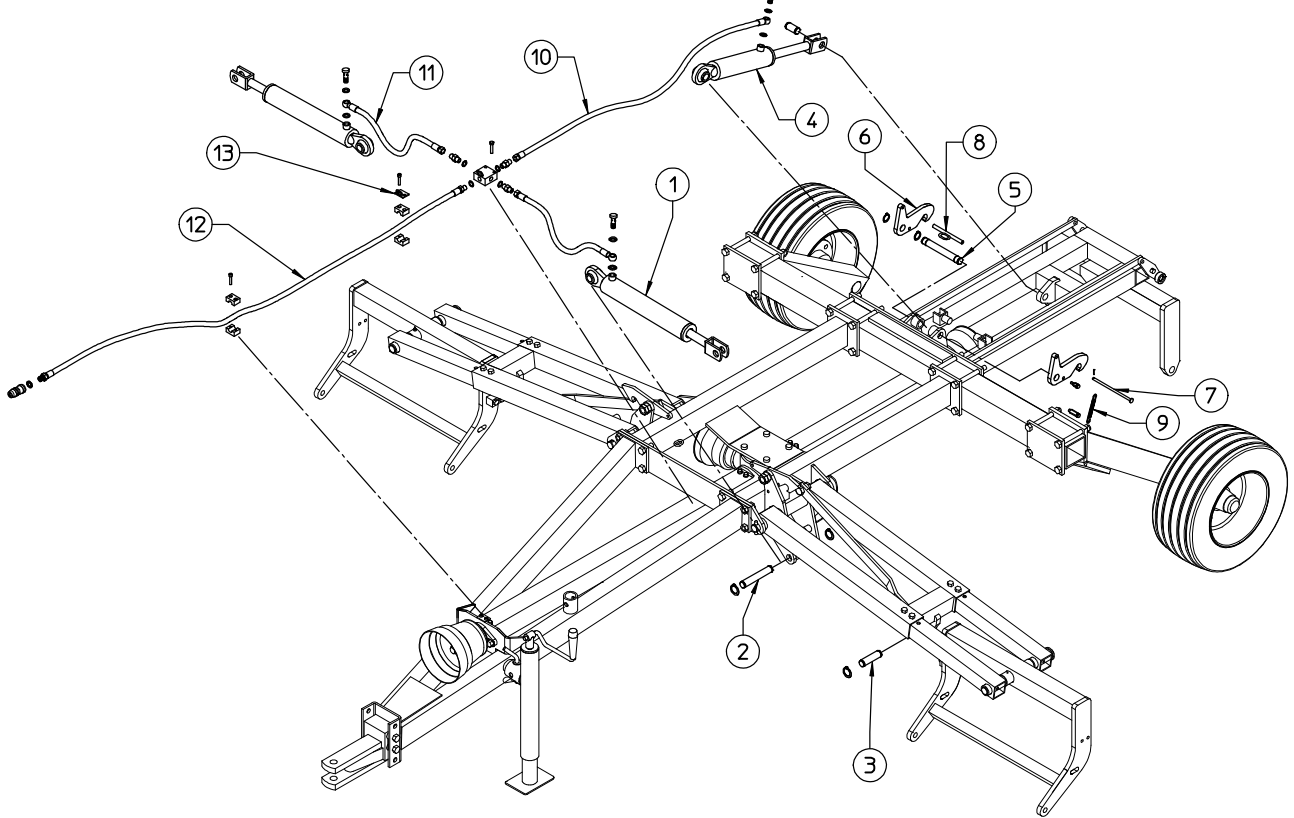

5.2.13 The frame is now complete and the rear and side cowls can be assembled.

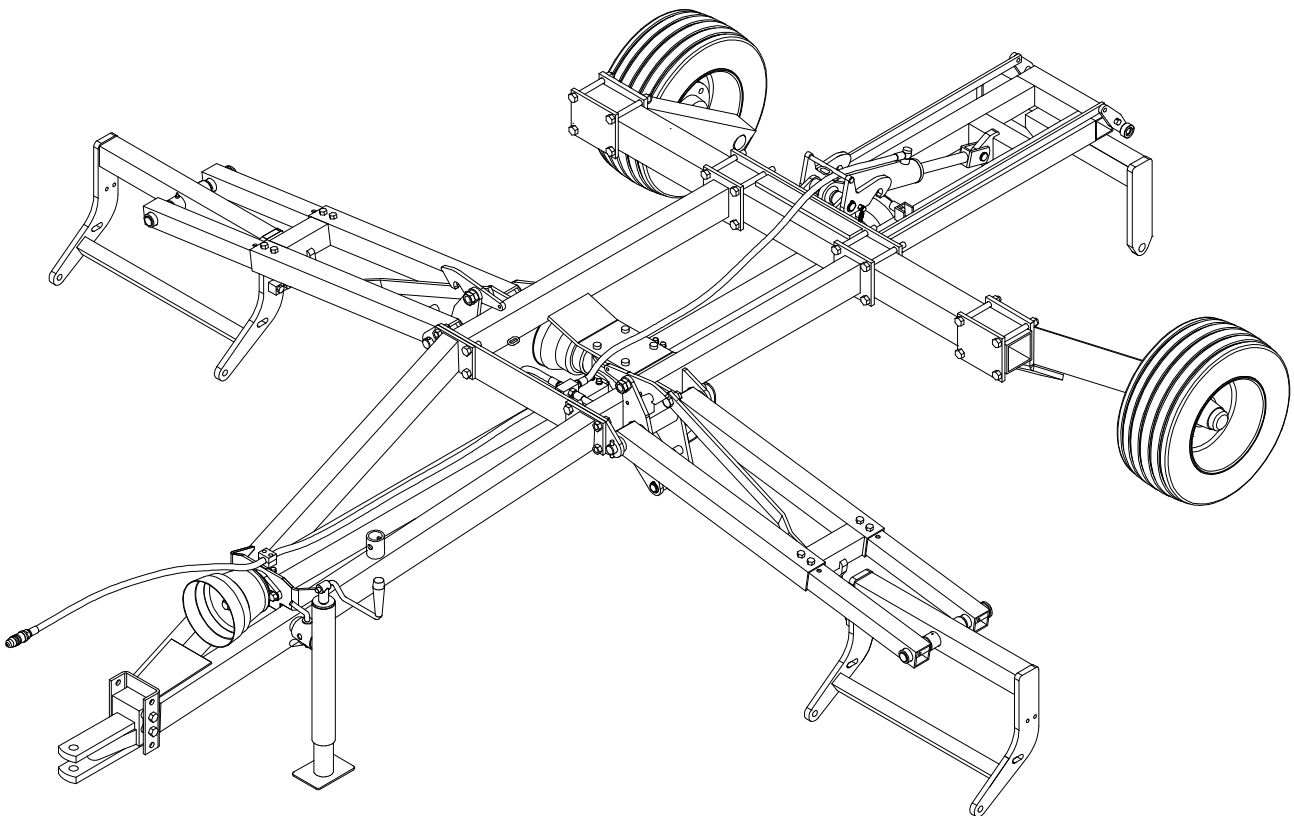

5.2.14 In order to assemble the rear cowl, place it behind frame 1, then insert the cardan shaft 18. Use the relevant pins 2 and 9 to fasten arms 3 and 10 to the frame 1, whereas pins 4 are assembled to control oscillation. Assemble arms 3 inside the cowl brackets with a hole A and insert pin 14 and arms 10 into hole B. Arm 10 must be assembled using screw 17 and nut 19. Some play must be left without tightening them completely.

Warning: the diagram shows a rear cowl with straight axles, for SM/3600. In fact the rear cowls for the SM/4500 and the SM/5200 have axles shared in two pieces.

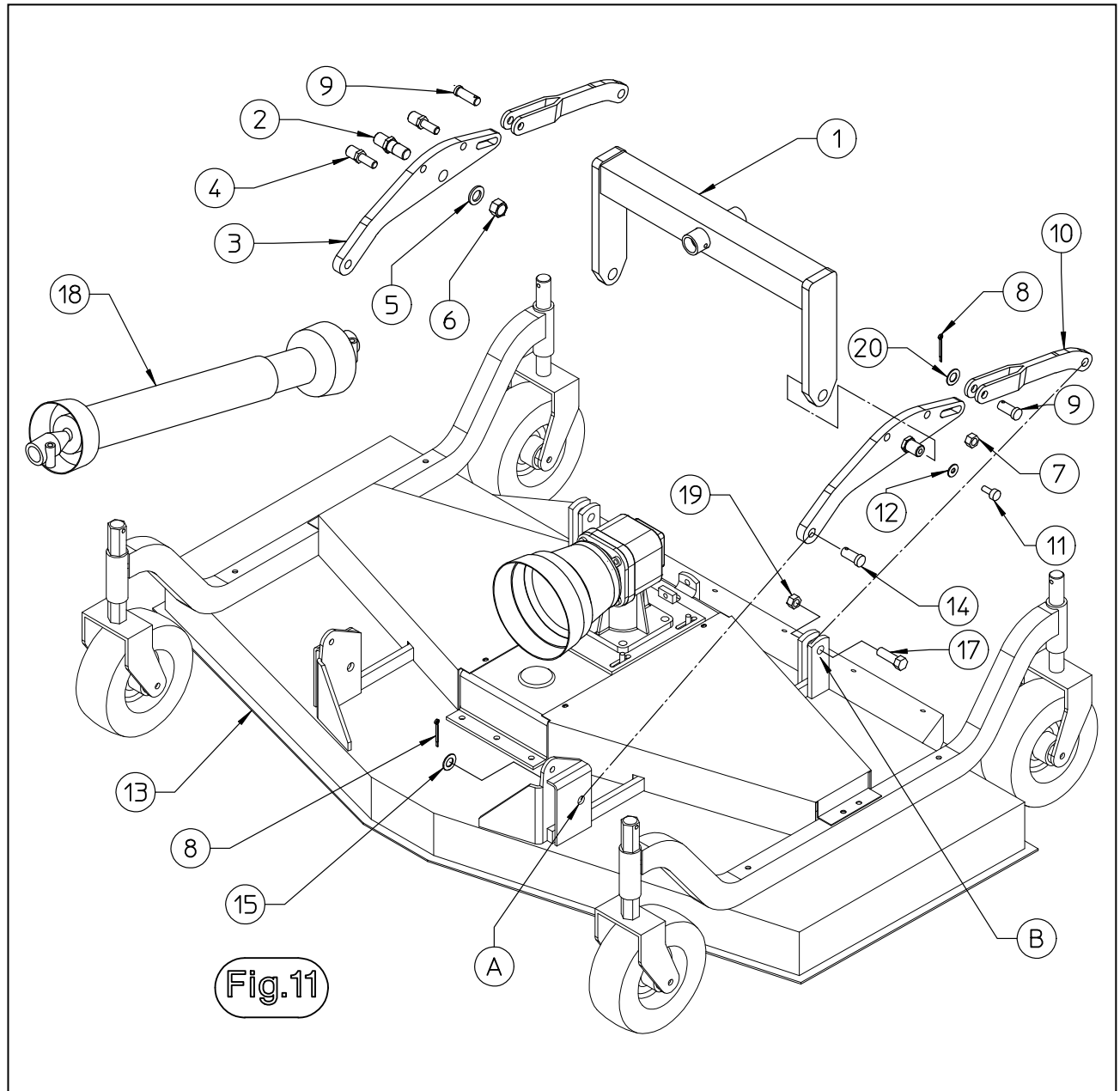

5.2.15 In order to assemble the side cowls, place the lower hole of frame 1 to match hole A on the cowl and then insert pin 6 and lock split pin 7. Then use pin 3 to fasten the tie rods 2 and match the rear hole to hole B on the cowl. There assemble a screws 8 and nut 9, do not lock nut 9, tie rods 2 to be free. Assemble the cardan shaft.

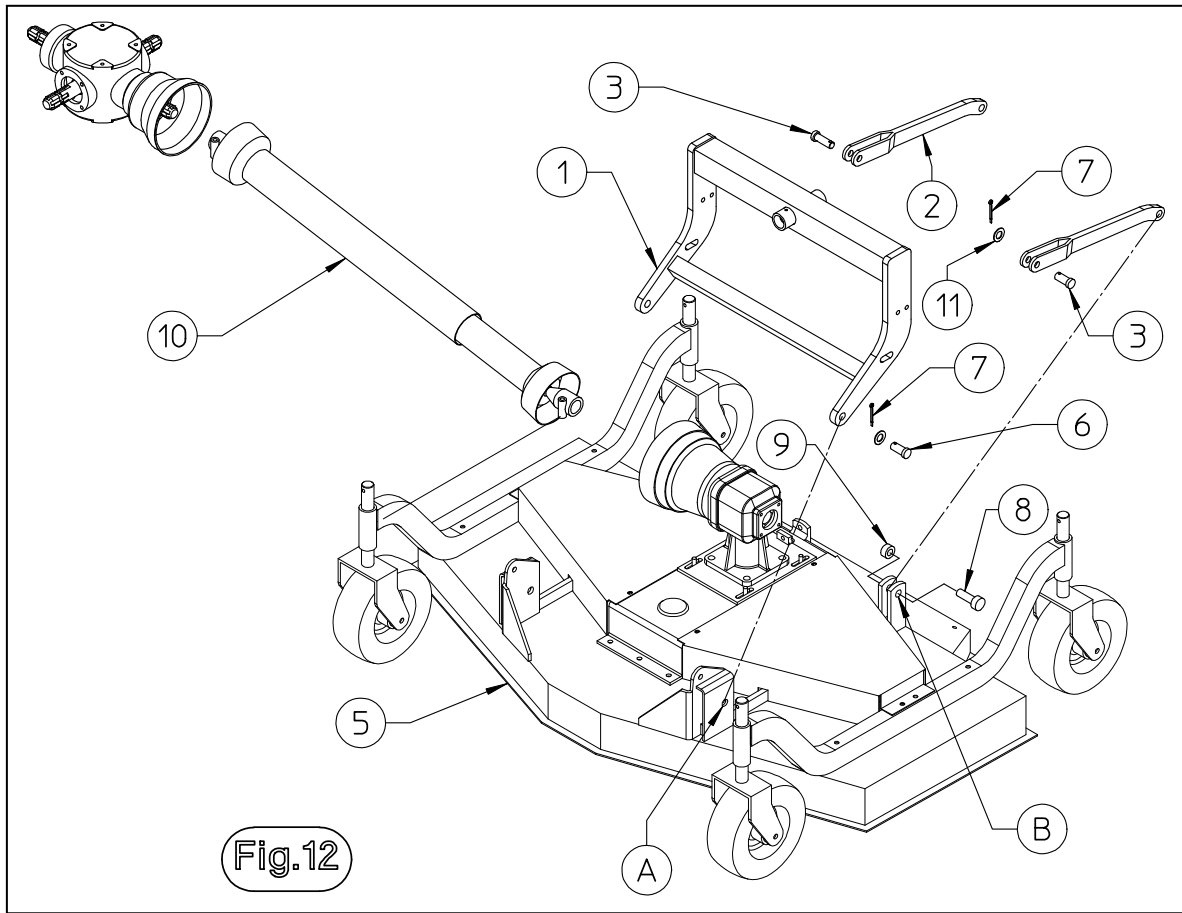
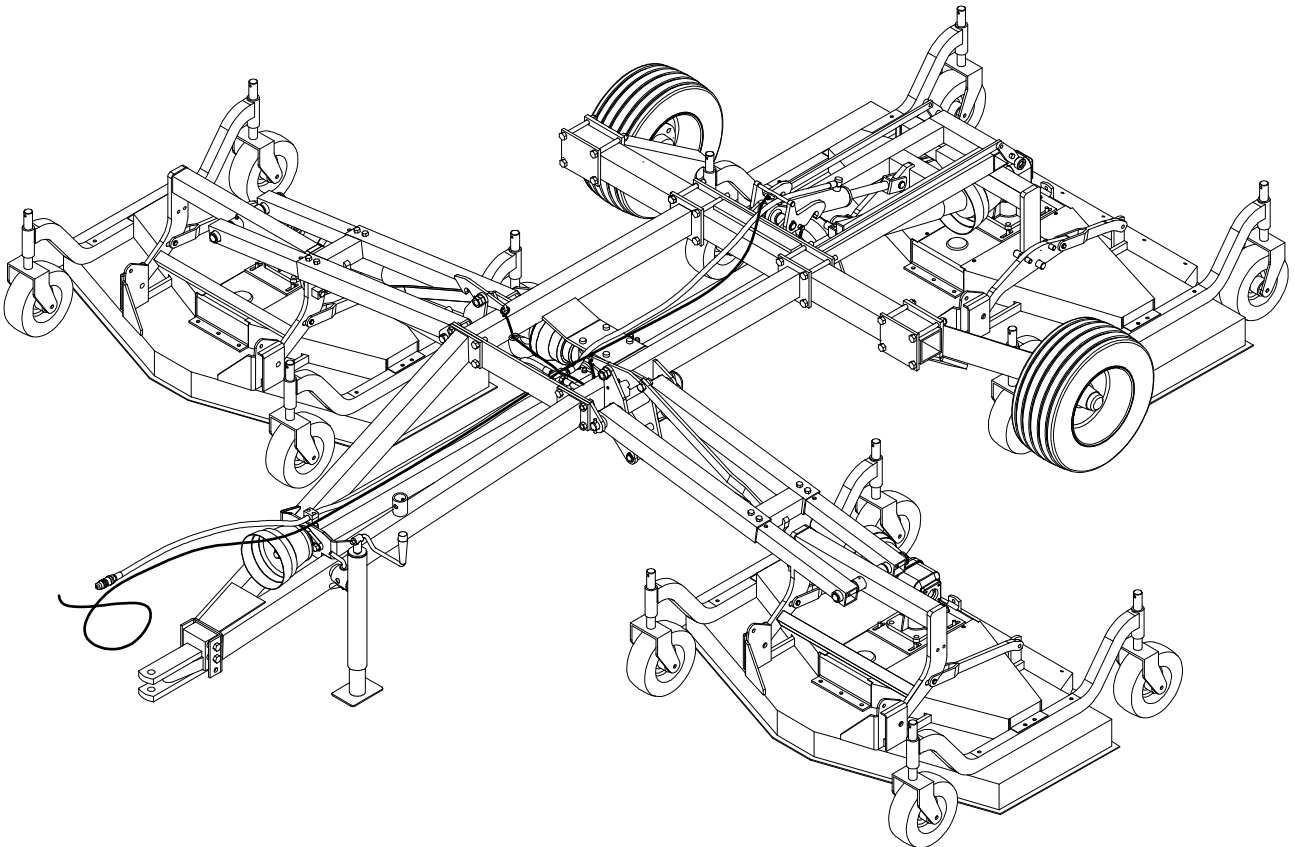

Fig.12

5.2.16 Finally, the cable to work the arm safety hooks has to be assembled. The cable consists of 3 parts attached on a level with the side arms. The three parts must all have the same tension, so that when the cable is stretched to enable the arms to be lowered, the three hooks operate simultaneously. The side cables must be passed inside the two rings welded on to the frame. The three cables must be joined after they have been passed through the first central ring, and finally the single cable passes through the ring nearest the tractor.





CHAPTER 6

ADJUSTMENT, PREPARATION AND USE

6.1 INTRODUCTION

- 1) Connection to the tractor is highly dangerous. Take great care and carry out the entire operation in strict compliance with the following instructions.
- 2) Nobody should go near the area between the tractor and the machine.
- 3) Check that all warning and danger signs are in place and legible.
- 4) Check that the tractor is in good running order.
- 5) Check the engine oil, gearbox oil, brake fluid and cooling water levels as well as the tire pressures.
- 6) Refer to the tractor operator's manual.

6.2 MOUNTING TO THE TRACTOR

In order to fasten the machine to the tractor, insert reverse gear so that the tractor draw-bar matches machine coupling 5 on the machine, and insert the pin to fasten into position. To enable the tractor hook to pass through coupling 5 on the machine, move foot 3. When the machine has been assembled, its frame should be parallel to the ground so coupling 5 can be assembled in either position A or position B by using two of the four holes F.

After having attached the machine, loosen foot 3 and remove it and place it on the rest bushing. Hook the hydraulic clutch to the tractor and place the cable near the driving seat.

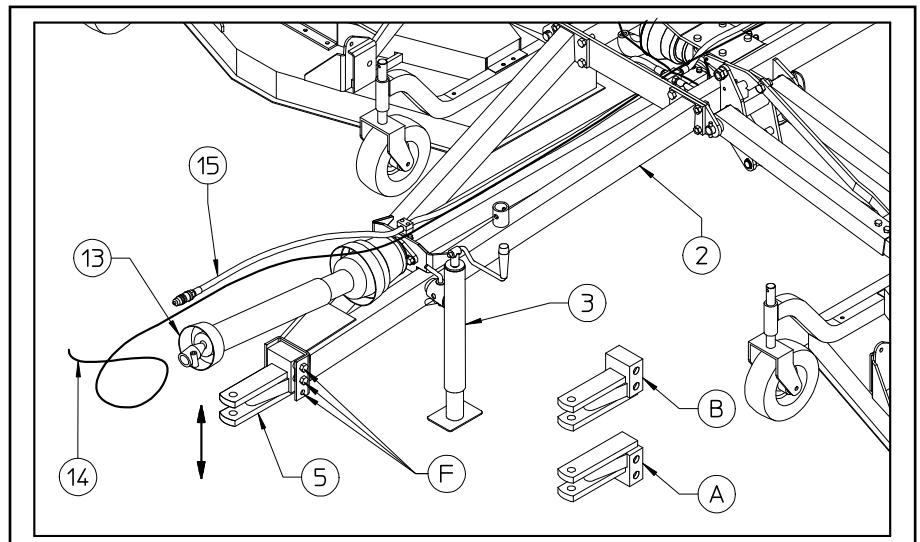



6.3 CONNECTING THE CARDAN SHAFT



More detailed information may be found in the Cardan shaft manual which, together with this manual, is an essential part of the accident-prevention documentation.

It is your responsibility to read and comply with this documentation. If information given in this manual should conflict with that given in the Cardan shaft manual, you should follow the instructions given by the Cardan shaft manufacturer.



Fit the Cardan shaft and check that the shaft is connected correctly both at the tractor end and at the machine end. For more details, see the descriptions on the following pages.

If a safety system is provided, this should be fitted to the machine end, not to the tractor end.

During both transport and use, avoid conditions where the Cardan transmission shaft is extended to the maximum. In all working conditions, the telescopic tubes must overlap by at least 1/3 of their length (Fig.6.1).

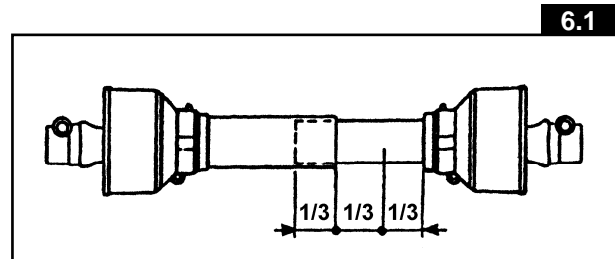

Conversely, when the Cardan shaft is contracted to the maximum, there should still be a gap of approximately 50 mm (2") (Fig.6.2).

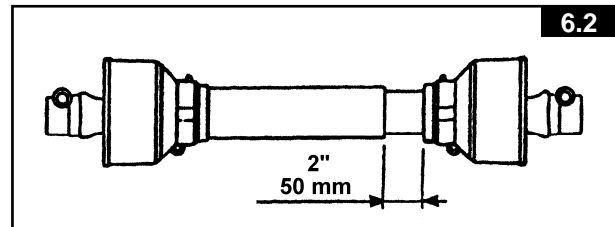

Take particular care when connecting the two Cardan shaft end forks and make sure that they are fully secured. This is achieved by inserting the safety pins and bolts (1) (Fig.6.3.) in the special slots (2) on the power takeoff shafts on both the tractor and machine ends.

A loose shaft could come apart and cause considerable mechanical damage and serious injury to persons.

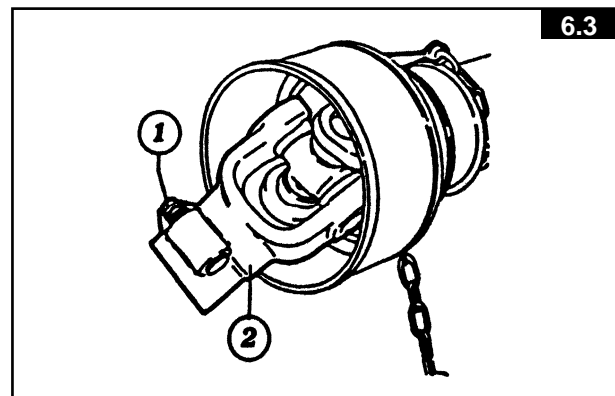

6.4 TRANSPORT BY ROAD



After the machine has been attached to the tractor as previously described and before transporting it to or from fields or any other workplace, the following instructions should be heeded:



Before setting off with the machine attached to the tractor, check the local road transport regulations. During transport keep the machine fully raised with the power takeoff disengaged and the lifting unit immobilized. Check that all guards, safety protection and locking split pins are in place, functioning and correctly fitted.

Warning: The hydraulic cylinders have to be used to transport the machine in order to raise the arms with the cowls; when the arms are raised, check that the safety hooks have firmly blocked their respective pins. Ensure that nobody leans against, or climbs on to, the machine during transport. The machine is an agricultural machine ***NOT designed for transporting persons or goods***. Consult the tractor maintenance and-use manual where necessary. Maintain constant control over the vehicle and ensure that you know how to stop the tractor quickly and switch off the engine.

When on a public road, observe all Highway Code regulations. Drive near the edge of the road and try not to obstruct traffic.

Do not park the tractor and/or the machine where it might obstruct, or be a danger to, any public right of way. Avoid going onto a public road if the tractor or machine is very dirty - you could leave a trail of soil, grass and other matter which could dirty the road and obstruct normal traffic.

The machine is not suitable for long journeys on public roads.

The hydraulic cylinders have to be used to transport the machine in order to raise the arms with the cowls as shown in the following diagram. When the arms are raised, check that the safety hooks have firmly blocked their respective pins.

Warning: before raising the machine make sure that the blades are not moving, and once the cowls have been raised, make sure they cannot start rotating.

The first time the machine is raised, pay special attention. When you start to raise the machine, check that all the parts are attached correctly.

The first time the cylinders are used, they are full of air and will, therefore, operate irregularly. The cylinders must be raised and lowered several times in order to remove the air from the oleo-dynamic circuit. However, the first time they are used, make sure there are no leaks from the pipes and pipe fittings (the latter must be checked at a later stage).

When transporting the machine, check the overall dimensions and make sure that no movements will be able to hit either people or other obstacles.

Check the combined weights of the machine to see whether they are compatible with the specifications in the tractor handbook (the weight of the triple mower is given in this handbook). However, when carrying out manoeuvres with the machine attached, pay extra attention as compared to normal conditions.

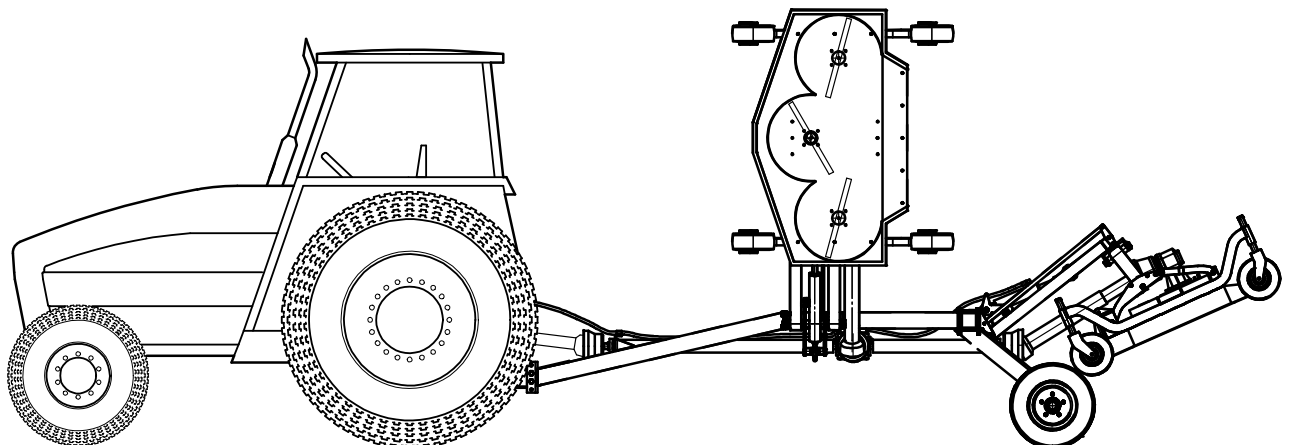

6.5 GENERAL INSTRUCTIONS FOR FIELD USE

Before starting work, familiarize yourself with the following general instructions:



Before using the machine ensure that all safety precautions are taken. Check that all safety protection and guards are in place and working. Inspect the work site in order to familiarize yourself with the terrain.

Do not start the tractor before being properly seated in the driving position.

Do not start the machine if it is damaged (or even if you only suspect it is damaged) and inform your nearest dealer of the problem and ask for assistance.

Do not allow yourself to become distracted when working: give your full attention to the job in hand.

Maintain constant control over the tractor and ensure that you know how to stop quickly and switch off the engine.

Caution when working on inclines. It is better to work from the bottom to the top of an incline (or from the top to the bottom), rather than across an incline where there is a risk of overturning. Check and heed the instructions supplied by the tractor manufacturer, especially those concerning the maximum incline on which it is possible to work.

It is advisable to reduce speed when working and maneuvering on inclines and only to change speed and direction gradually. Do not make sudden stops or starts.

Do not work on wet or slippery grass or terrain, or anywhere where grip is poor. If this is unavoidable, work at a slow speed so as to ensure operator safety.

Always switch off the tractor engine, apply the parking brake and remove the ignition key whenever you have to attend to the machine to make adjustments or to remove grass and other objects which might be entangled in the machine.

Before leaving the tractor, disengage the power takeoff, lower the machine until its wheels are on the ground and put the hydraulic directional control lever into the locked position.

Never go near the rotors until they have completely stopped moving.

Never attempt to make adjustments to the machine while it is running. Always stop the machine before carrying out any such work. Do not oil the machine when it is running or is connected to the power takeoff.

Do not use the control levers as handholds since they can move and do not give a secure grip. Furthermore, any involuntary movement of a control lever can cause unintentional movement of the tractor or machine.

Warning: when using tractors of over 50HP, turn on power take-off slowly in order to avoid any recoil due to the sudden ignition of a very high power, which could damage the cardan shafts and the gear boxes.

Danger: never switch on the tractor power take-off until the 3 mower cowls have been lowered to the ground. Never raise the 3 mower cowls before the blade rotary movement has stopped completely. If these basic safety procedures are not followed, people could be seriously injured and the gear boxes and machine cardan shafts could be damaged.

6.6 GENERAL INSTRUCTIONS FOR USE



In addition to the instructions given above, each time you have to make adjustments before and during work, we recommend moving the tractor and machine to a firm, flat open area.

Before getting off the tractor to make adjustments, follow this procedure exactly:

- 1) Lower the machine until its wheels touch the ground (this is recommended every time the tractor is stopped for any reason).
- 2) Put the hydraulic directional control lever on the tractor into the locked position.
- 3) Switch off the engine, leaving the tractor in gear.
- 4) Apply the parking brake.
- 5) Remove the ignition key from the instrument panel.

Now prepare the machine for field use as indicated below.

6.6.1 PRELIMINARY CHECK

Ensure that:

- 1) The power takeoff speed is 540 r.p.m. (for special machines made on request, gearboxes are fitted and preset for power takeoff with a speed of 1000/2000 r.p.m.).
- 2) The direction of rotation of the tractor's power takeoff corresponds with that of the gearbox, because the ***cutting blades "A" must rotate in the direction indicated by the arrows.***
- 3) The machine is assembled correctly and in good operating condition by following the instructions of this manual and therefore guaranteeing maximum safety.

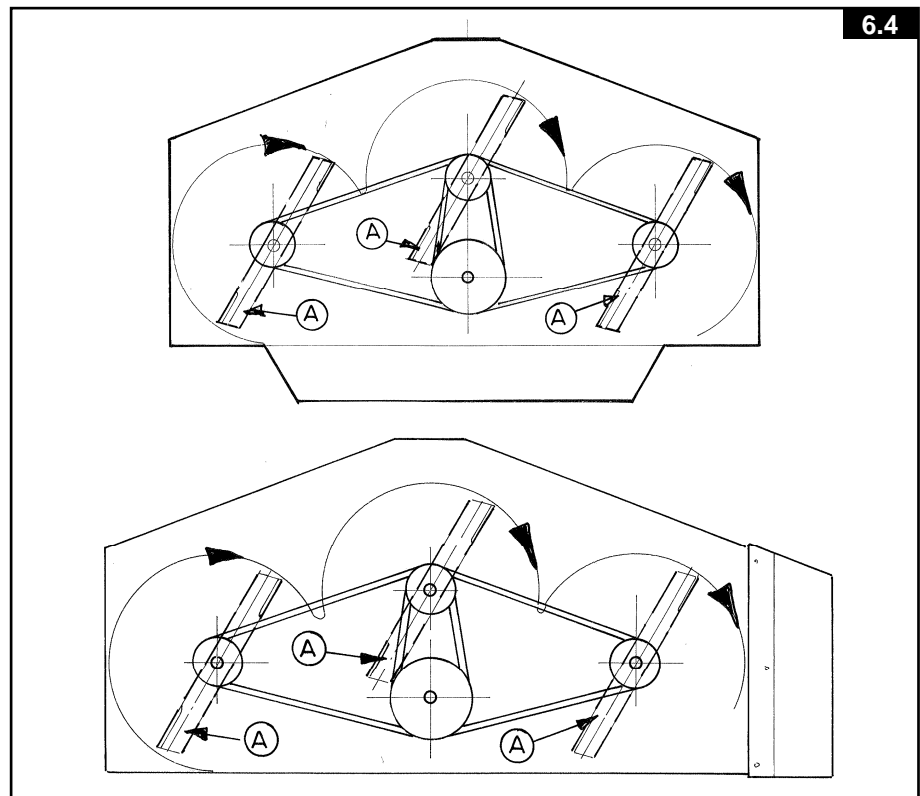

6.4

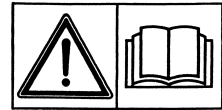

6.6.2 ADJUSTING THE CUTTING HEIGHT

The cutting height is determined by the shims 1-2-3-4-5, which are inserted between the wheel unit 6 and the axle 7 in various combinations.

These determine the different cutting positions ranging from a minimum of 15 mm (5/8") to a maximum of 92 mm (3" 7/8).

To carry out this operation you should keep the machine raised.

Remove the split pin 8 which secures the wheel unit 6 to the axle 7.

Then select the position of the shims which allows you to obtain the desired cutting height. Re-lock wheel unit 6 with the split pin 8.

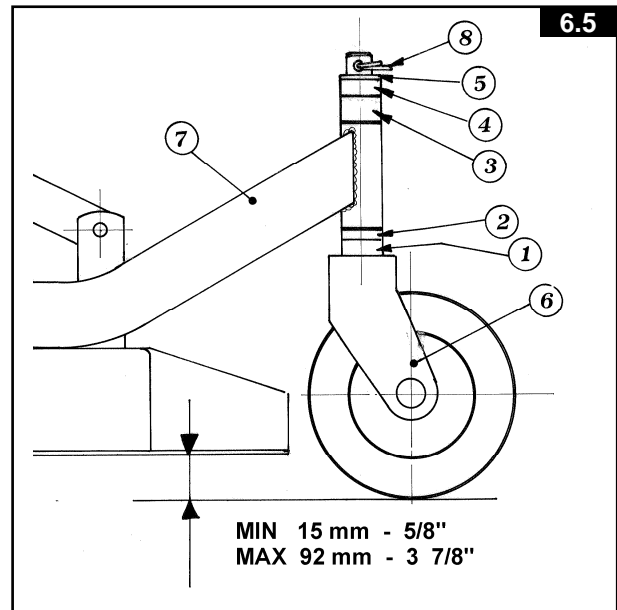

6.6.3 USE

When you wish to cut in the field, change the machine from its transport position to its working position.

Warning: Under no circumstances should anybody stand near the machine or any moving parts. It is the duty of the operator to ensure that this requirement is respected.

In order to change the machine to its working position, operate the cylinders so that the safety cowls are removed. Then use the cable to move the hooks and free the lock pins. Invert the movement of the hydraulic cylinders to lower the arms with the side and rear cowls.

Continue to lower the cylinders until the cowl rests freely on the ground. The tie rod must be placed at the end of the slot on the arm holding the cowl. Once the cowls have been placed on the ground, gently switch on power take-off and then begin to cut. Pay attention to the overall dimensions of the machine and if necessary, switch off power take-off and then raise the arms when the rotors have stopped, in order to avoid any obstacles. Lower the cowls to the ground once more before starting work again.

6.6.4 ADJUSTING THE MACHINE'S AND THE TRACTOR'S TRANSPORT ARM

In order to transport the machine, stop the rotary movement of the cutting blades. When the blades have stopped, use the hydraulic cylinders to raise the arms. The cylinders must continue to operate until the safety hooks have been inserted. Then check that the safety hooks are inserted correctly before transporting the machine. Make sure, however, you also follow the rules given in chapter 6.4.

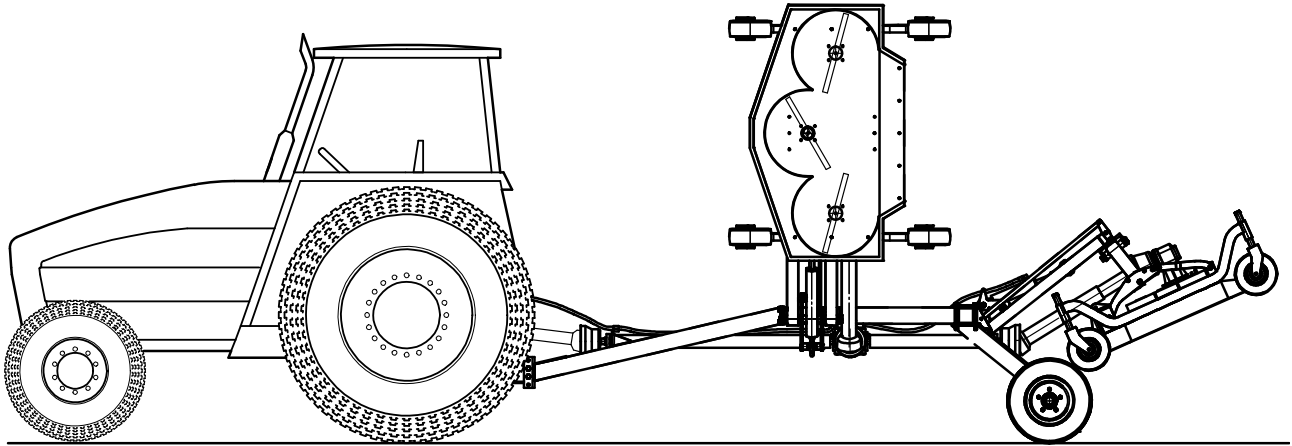

6.6.5 ADJUSTING THE BELT TENSION

The machine belts are tightened by the manufacturer, but after the running-in phase or whenever the cutting blades appear not to be functioning properly, it is necessary to re-tighten the belts to the correct tension. To do this one should carry out the following steps:

- a) Remove the screws 1 & 2 and take off the protective guard 3.
- b) Loosen the nuts 4 which secure the slide reduction unit 5.
- c) Loosen the lock nut 6,
- d) Adjust the screw 7 so that the slide reduction unit 5 can move in direction "A" until the belt 8 has a flexure in section "C" equivalent to the flexure "E" indicated in the table.
- e) Now re-tighten the screw 7 with the lock nut 6 and re-secure the slide reduction unit 5 with the nuts 4.
- f) Re-fit the protective guard and secure it with the screws 1 & 2.

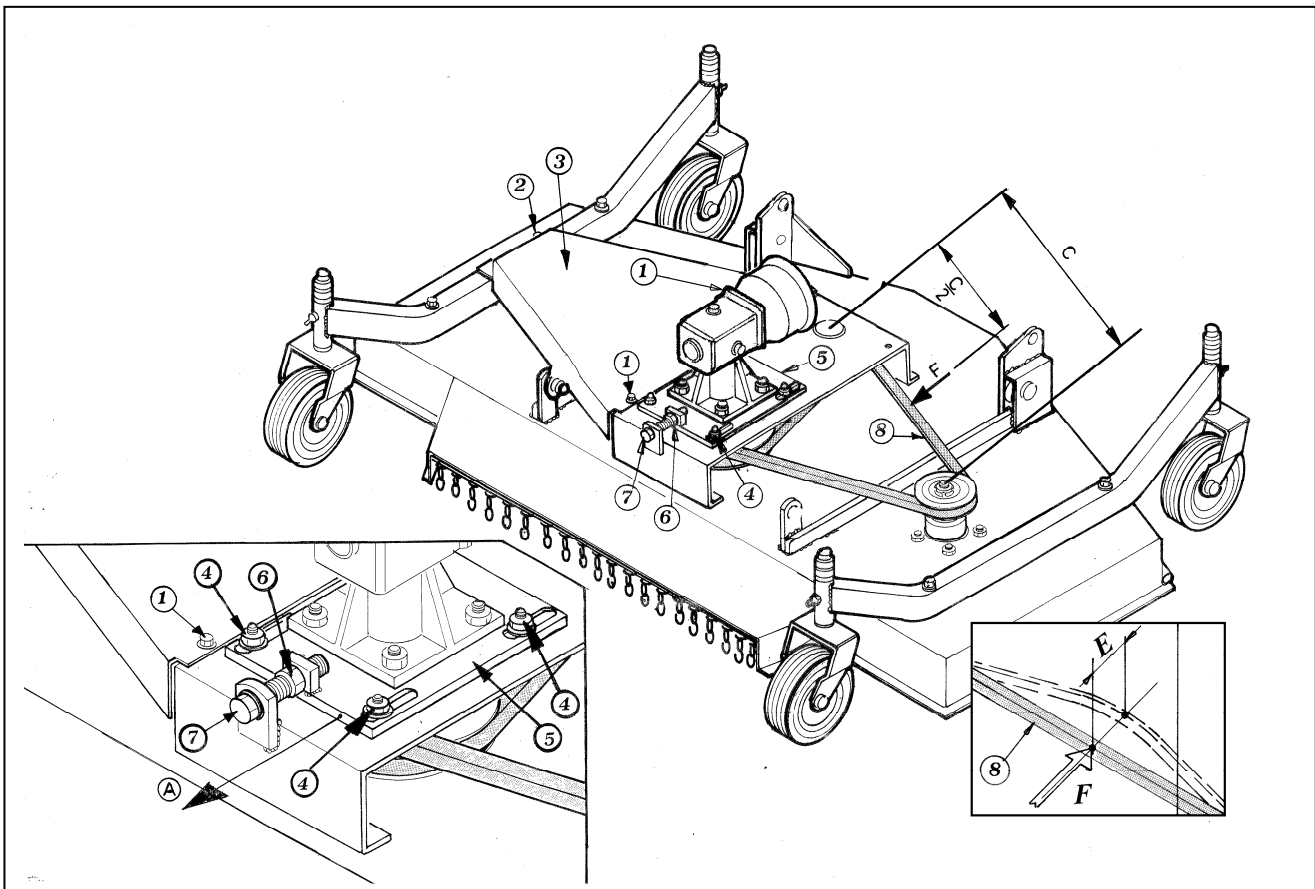

6.6.6 GENERAL RULE FOR CALCULATING THE TIGHTNESS OF BELT TYPES SPB / 5V / 15N / XPB / 5VX

For better understanding of general rule for calculating the tightness of belt see Fig. **Errore. L'origine riferimento non è stata trovata.**

$$E \cong \frac{K \cdot C}{100}$$

E = Flexure (mm) of a section of belt (C) subjected to a force (F) equivalent to 75 N (~7.5 kg) applied to the center of the section (C/2).

K = Flexure (mm) of a 100 mm (4") section of belt subjected to a force of 75 N (~7.5 kg) applied to the center of the section.

Diameter of the smallest belt pulley (mm)	Values of K (mm)
80<160	3
160<224	2.55
224<355	2.22
>355	2.1

C = Longer section of belt of transmission (mm).

C/2 = The middle of the longer belt of transmission where the force (F) must be applied (mm).

F = Force applied to check the tension of the belts, equivalent to 75 N (~7.5 kg).

The table below reports the right values for the finishing mowers:

Values of general rule parameters (mm)			
Parameters	Machine Model		
	SM 120	SM 150	SM 180
K	3	3	3
C	422	522	622
E	12.5	15.5	18.5

6.6.7 REPLACING THE BLADES



If possible, carry out this operation in a workshop after having detached the machine from the tractor and raised it with a suitable hoist (see page 15). If there is no choice but to carry out the operation on the field, choose a firm, level spot.

- a) Raise the machine to the tractor hoist's maximum height and apply the parking brake.
- b) Disconnect the power takeoff, turn off the tractor and remove the key from the ignition.
- c) Insert a support between the machine and the ground to prevent it from falling.
- d) At this point tighten the hub pin 2 with the wrench 1 and unscrew the nut 4 with the wrench 3.
- e) Then remove the blade 5 and replace it with a new one.
- f) Now re-tighten the nut 4.

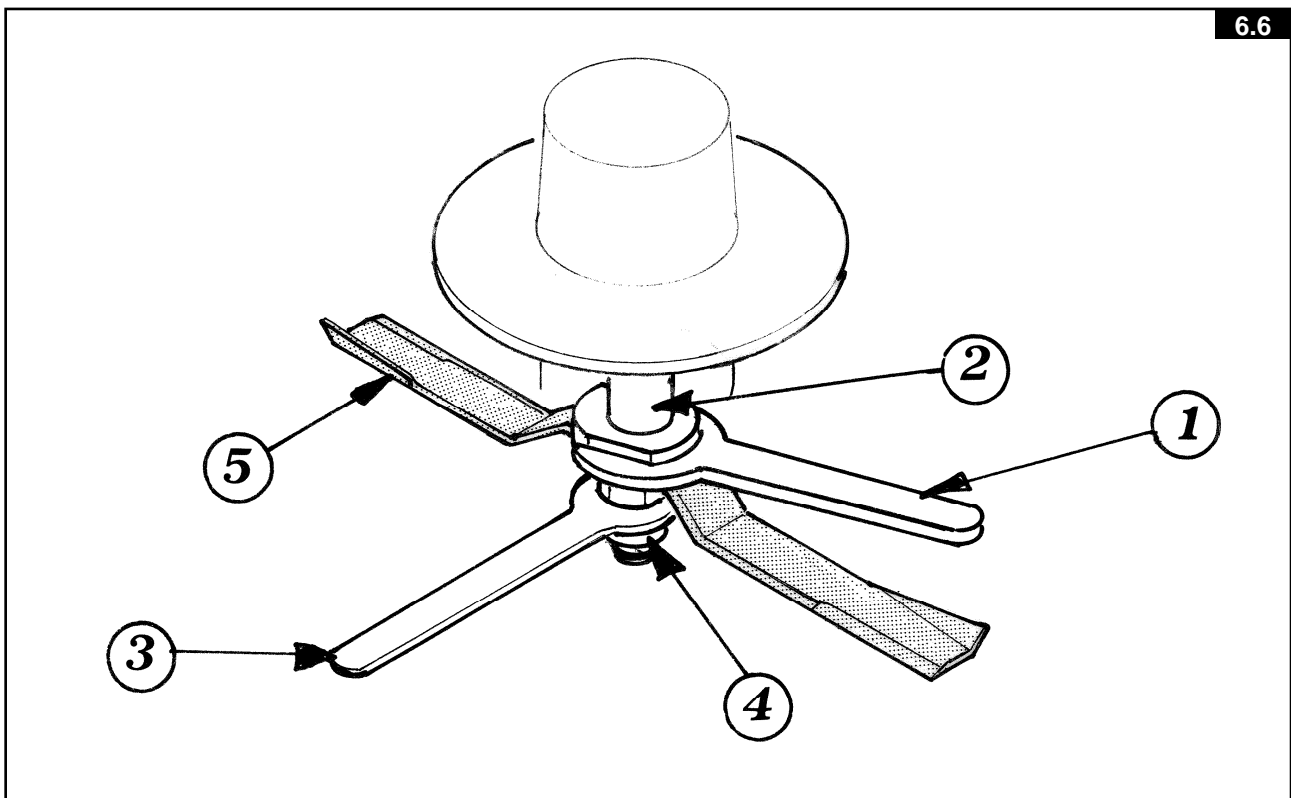

6.6.8 TEMPORARY PARKING

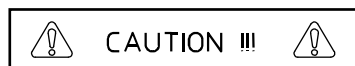

If the machine has to be temporarily parked proceed as follows, bearing in mind the instructions in CHAPTER 3.

Before getting off the tractor, follow this procedure exactly:

- 1- Choose a flat, hard open space, away from frequented areas if possible.
- 2- Lower, the machine until its wheels touch the ground (this is recommended every time the tractor is stopped for any reason).
- 3- Put the hydraulic directional control lever on the tractor into the locked position.
- 4- Switch off the engine, leaving the tractor in gear.
- 5- Apply the parking brake.
- 6- Remove the ignition key.
- 7- Repeat the operations described on point 6.2 page 25, but in reverse.

To park the machine: In order to park the tractor with the machine attached, place it far from any obstacles and then rest the cowls on the ground according to the instructions described above.

To release the machine: When the machine has to be released from the tractor, reverse back into the place where the machine has to be deposited. Check there are no obstacles and then lower the arms to the ground. Operate the support foot so that the drag pin can be removed. Unhook the quick-release clutch and remove the cable from the cabin. The tractor can now be moved away from the machine. This operation must be carried out so that the machine is left on a firm, safe surface.

CHAPTER 7

MAINTENANCE

7.1 MAINTENANCE DIRECTIONS



 DANGER !!! 

All cleaning, lubrication and maintenance operations must be carried out with the machine disconnected from the tractor. In an emergency with the machine still connected to the tractor, switch off the engine, apply the parking brake, disengage the power takeoff and remove the ignition key from the instrument panel. Regular, correct maintenance and proper operation are the basic prerequisites for the long-term efficiency and safe operation of the machine.

Pay special attention to all instructions given on signs located on the machine.

All maintenance should be carried out in an area having the proper equipment readily available and in good condition. This area must always be kept clean and dry and must, have enough surrounding space to facilitate operations.

Any work must be carried out by trained personnel. Contact the dealer nearest to you.

Respect the warnings and procedures for maintenance and technical assistance given in this manual.

Do not use petrol, solvents or other flammable liquids as detergents.

Use commercial non-flammable and non-toxic solvents, authorized by competent bodies.

Do not use compressed air or water at high pressure to clean the machine. If this is unavoidable, then wear goggles with side protection and limit the pressure as much as possible. When the work is finished, and with the machine disconnected from the tractor, inspect and check the machine completely.

7.2 REPAIR INSTRUCTIONS



 DANGER !!! 

Any repair work must be carried out with the machine at rest and disconnected from the tractor. Do not carry out welding without authorization and instructions from the manufacturers. Disconnect the machine from the tractor before any welding work in order not to damage the battery. Always use a protective mask, goggles and gloves when welding, sanding or grinding or when using a hammer or drill. Always work on the machine out of doors. If you have to operate the machine when connected to the tractor in an enclosed area (for example when testing after repair and/or maintenance), ensure that there is sufficient ventilation so as to prevent noxious exhaust gases accumulating. In order to acquire the necessary control and to operate in safety, practise various manoeuvres by simulating those required in the workplace with the help of an experienced person. If you activate the machine while it is raised from the ground, make sure there is nobody standing nearby or in a dangerous position.

7.3 LAYING UP FOR EXTENDED PERIODS

At the end of the season, or when an extended period of inactivity is envisaged, it is advisable to:

- a) Clean the machine following instructions and allow it to dry.
- b) Check it carefully and replace any damaged or worn parts.
- c) Thoroughly tighten all screws and bolts.
- d) Grease the machine thoroughly and then cover it completely and lay it up in a dry place.

It is to the user's advantage to carry out these operations carefully. In this way, he will have a machine in perfect condition when work is restarted. On recommencing work, repeat all the proper checks so as to be certain of working in conditions of maximum safety.

7.4 MAINTENANCE AND TESTING

To effect the lubrication of the blade hubs 1 and the testing of the belt tension 5, it is necessary to remove the protective guard "A" (see page 32).

Once these operations have been completed, re-attach the protective guard "A" properly.

To change (or top up) the oil, remove the caps B & C from the gearbox 3.

Pour the oil into the hole of cap B until it comes out of the hole of cap C, and then put back both caps.

The quantity of oil needed for a complete change is 0.5 litres.

The type of oil used must be in accordance with regulation ISO 320 VG.

The maintenance table specifies how often the oil should be changed.

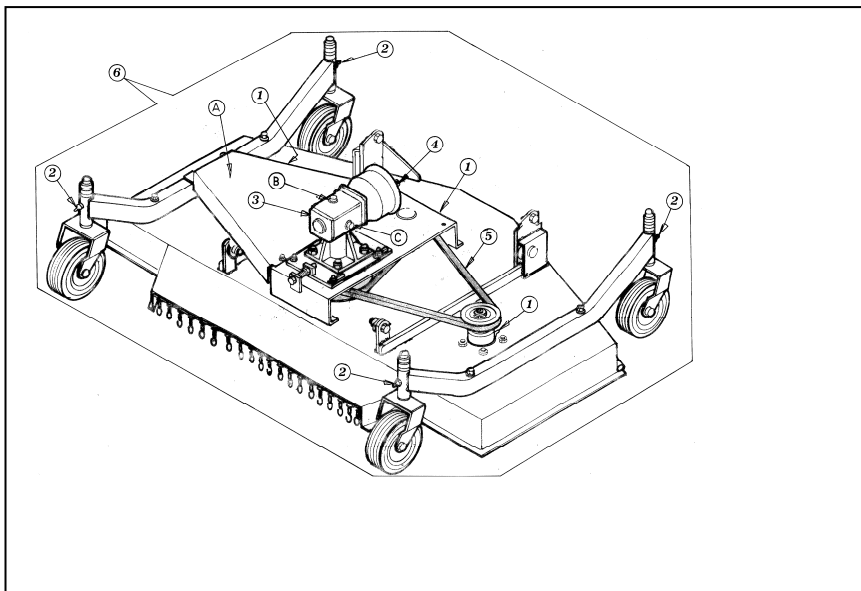
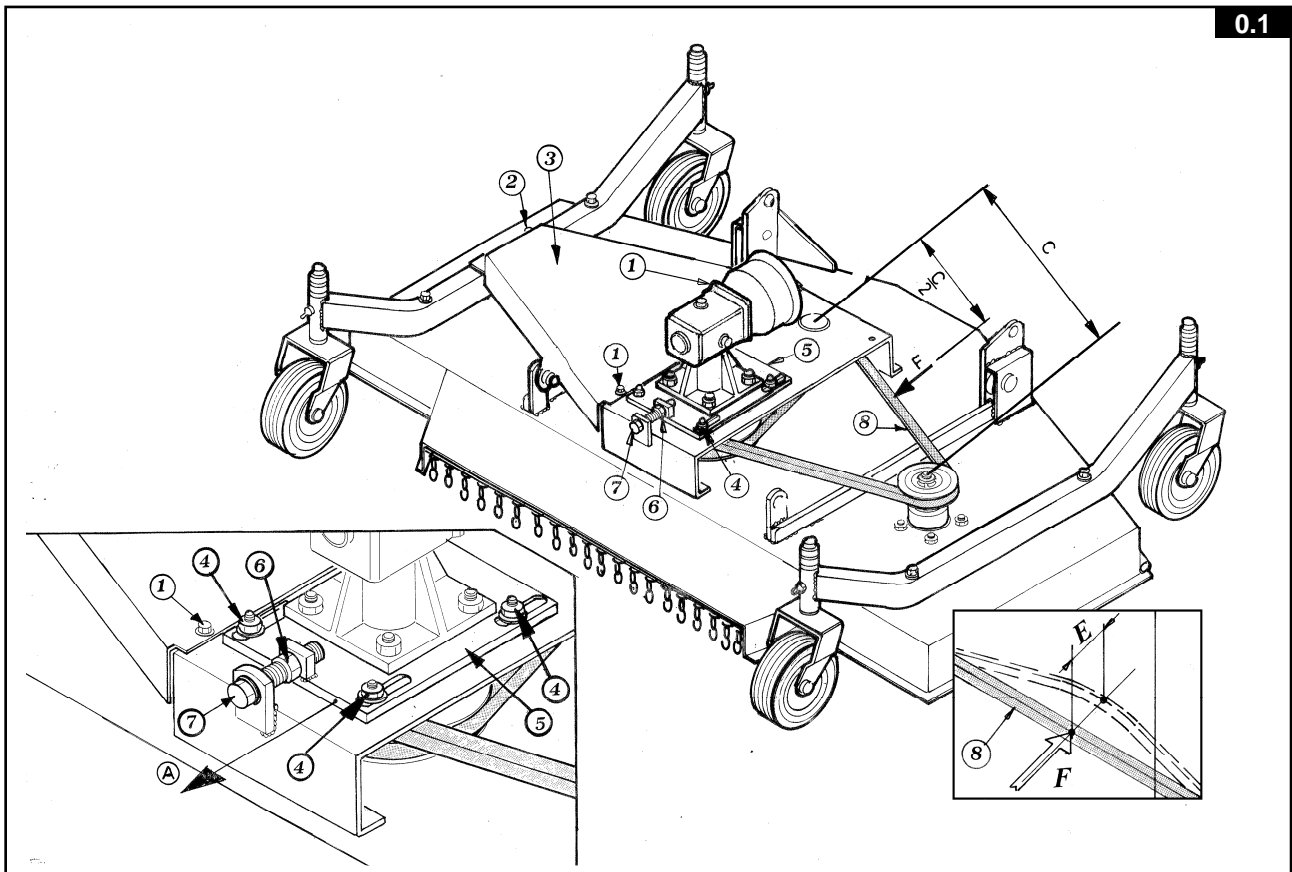

7.5 MAINTENANCE POINTS

No.	Qty.	Description	Operation	Every x hours	Product to use
1	3	Blade hubs	Lubricate	8	Grease *
2	4	Wheel supports	Lubricate	25	Grease *
3	1	Gearbox	Top up or oil change	X	Oil **
4	1	P. T. O. Shaft	Clean	Y	—
5	2	Belts	Check tension	50	See page 31
6	9	Pin	Lubricate	25	Grease *
	—	General checking of bolts, security pins and split pins to be carried out initially after the first 8 hours of use. Subsequently every 50 hours and whenever the machine is laid up for extended periods.			

Note:

X= First time after 50 hours. Then every 500/800 hours. It is advisable anyhow to replace oil at least once a year. Check oil every 50 hours.

Y= Each time the Cardan shaft is disconnected and whenever the machine is stopped, we recommended that you clean the power takeoff shaft and replace the protective cover.

* Grease type: NLGI2

** Oil type: ISO 320 VG (SAE 80W/90 EP)

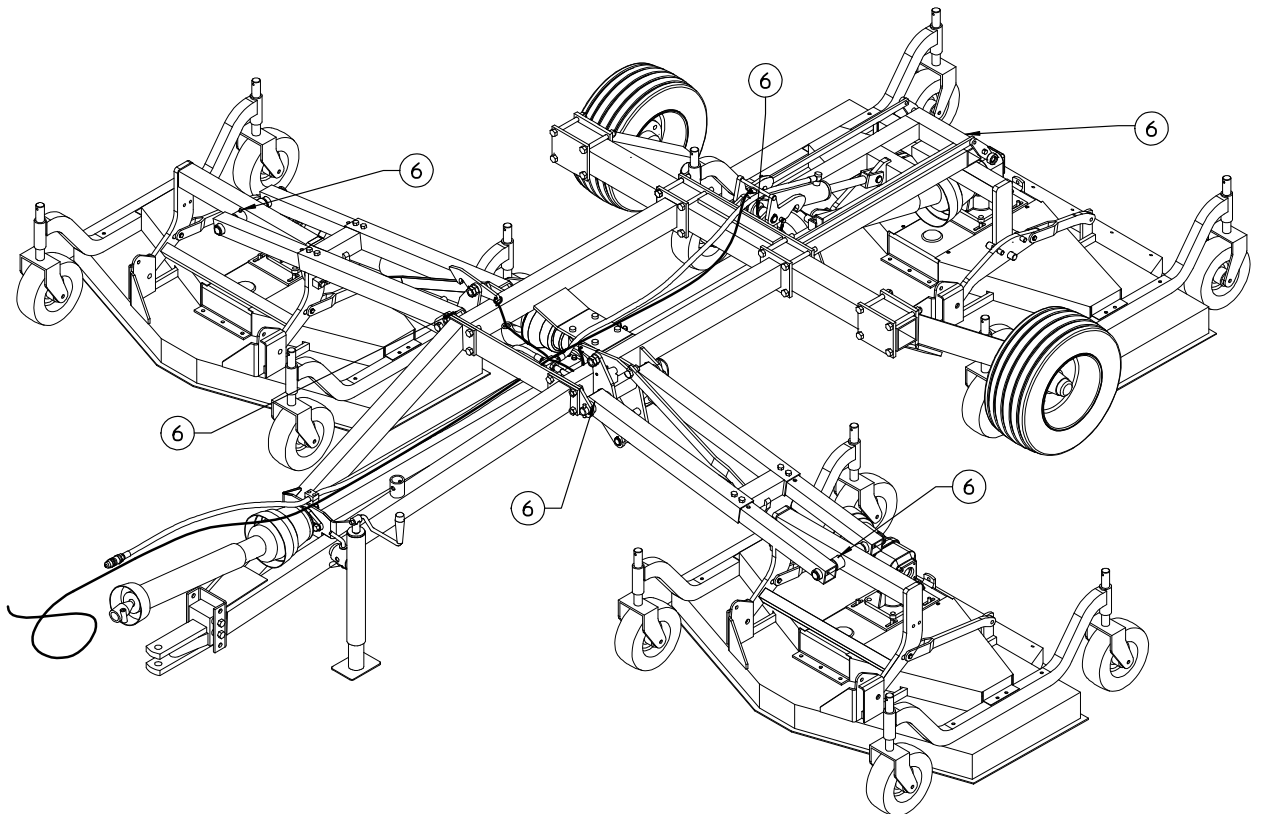

7.6 CARDAN SHAFT MAINTENANCE



More detailed information may be found in the Cardan shaft manual, which, together with this manual, forms an essential part of the accident-prevention documentation. It is your responsibility to read and comply with this documentation.

If information given in this manual conflicts with that given in the Cardan shaft manual, you should follow the instructions given by the Cardan shaft manufacturer.

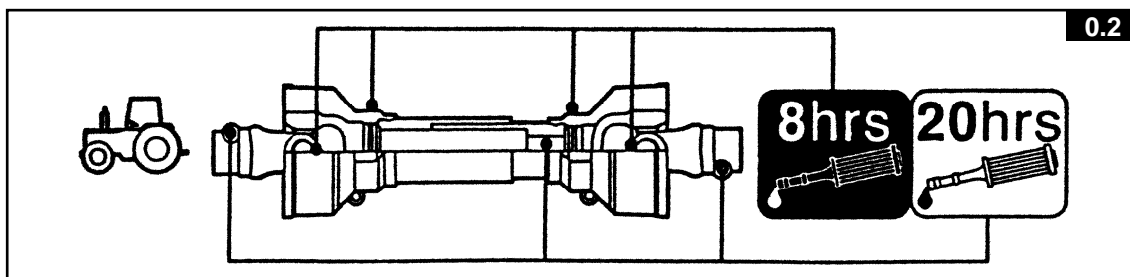

7.6.1 MAINTENANCE OF SLIDING PARTS

DISMANTLING

Turn the two eccentric pins on the ferrule until the protective cone comes free.

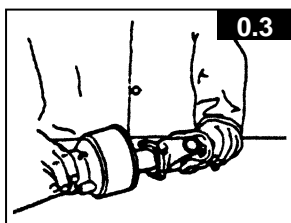

Withdraw the shaft protective guard.

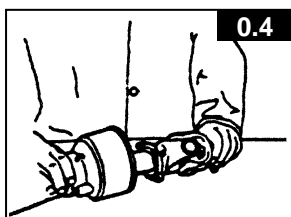

Check the condition of the ferrule and all protective parts.

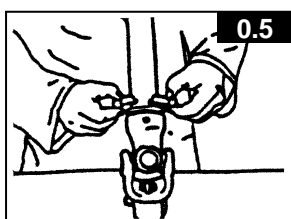

ASSEMBLY

Lubricate the supporting ferrule seating.

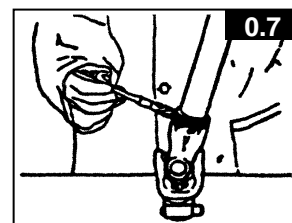

Refit the supporting ferrule.

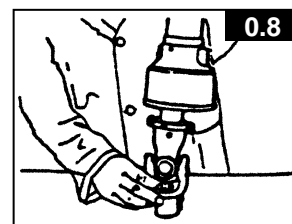

Reattach the protective guard to the Cardan shaft by turning the eccentric pins on the supporting ferrule.

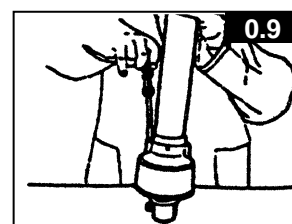

7.7 NOISE AND VIBRATION

Noise affecting the tractor driver (from the machine only) is less than 70 dB.

Vibration from the machine affecting the upper body and limbs of the driver is insignificant and is lower than the values given in Point 3.6.3 of Enclosure 1 of the Machine Directives (89/392/EEC, 91/386/EEC).

7.8 SCRAPPING THE MACHINE

The machine consists mainly of ferrous material which must be disposed of according to the regulations in force in the country concerned.

There is also a small amount of plastic, which must be disposed of according to the regulations in force in the country concerned.

There is a very small amount of residual grease which must be disposed of according to the regulations in force in the country concerned.

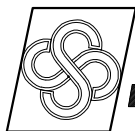

sitrex[®] AGRICULTURAL MACHINERY Spa

Zona Industriale-Viale Grecia, 8
06018 TRESTINA-(Perugia)-ITALY
Tel. +39.075.8540021-Telefax +39.075.8540523
e-mail: sitrex@sitrex.it www.sitrex.com

