

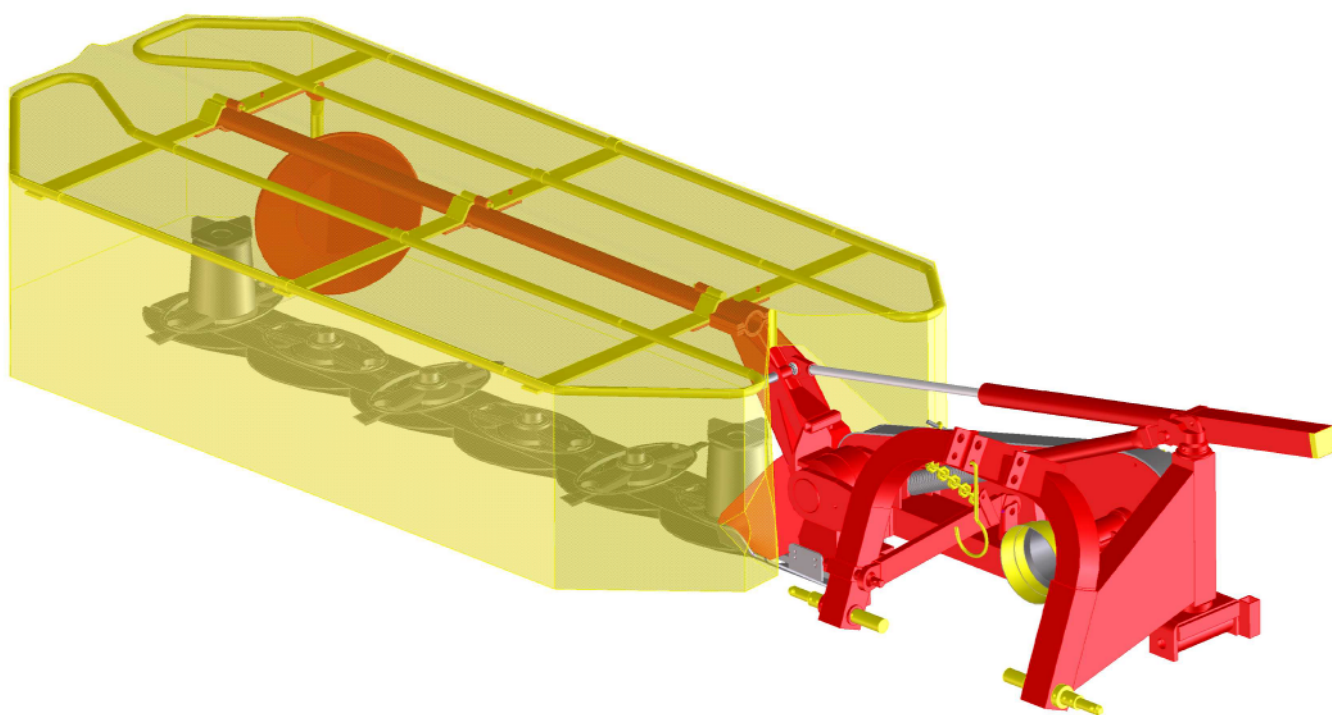

AGRICULTURAL MACHINERY
sitrex®
Spa

***SPARE PARTS LIST
ASSEMBLY
USE AND MAINTENANCE***



DM/4 - DM/5 - DM/6 - DM/7

1. Warranty

On delivery, check that the machine has not been damaged during transport and that all the attachments are present. Claims must be made in writing to the agent within 8 days of receipt.

The manufacturer warrants new machinery at the time of delivery to the original purchaser to be free from defects in material and workmanship if properly set up and operated in accordance with this Operator's Manual.

The manufacturer undertakes to repair or replace free of charge any defective part which should be returned by the purchaser (freight prepaid) and found to be defective by inspection authorized by the manufacturer during the warranty period.

This warranty will be valid for 12 (twelve) months from the delivery of goods to the original purchaser.

In case the customer is not in a position to return the defective part to the manufacturer, the manufacturer cannot be held responsible for any cost due for repair or replacement of any part of the machine, he will only supply the part(s) required for the repair and/or replacement.

The warranty is null and void when it is evident that the machine has been improperly used or repaired or however repaired without authorization.

The manufacturer undertakes no responsibility for any obligation or agreement reached by any employers, agents or dealers, which are not in compliance with the above warranty. The manufacturer cannot be held responsible for the consequent damages. This warranty substitutes any other warranty, express or implied, and any other manufacturer's obligation.

TABLE NO. 910.036

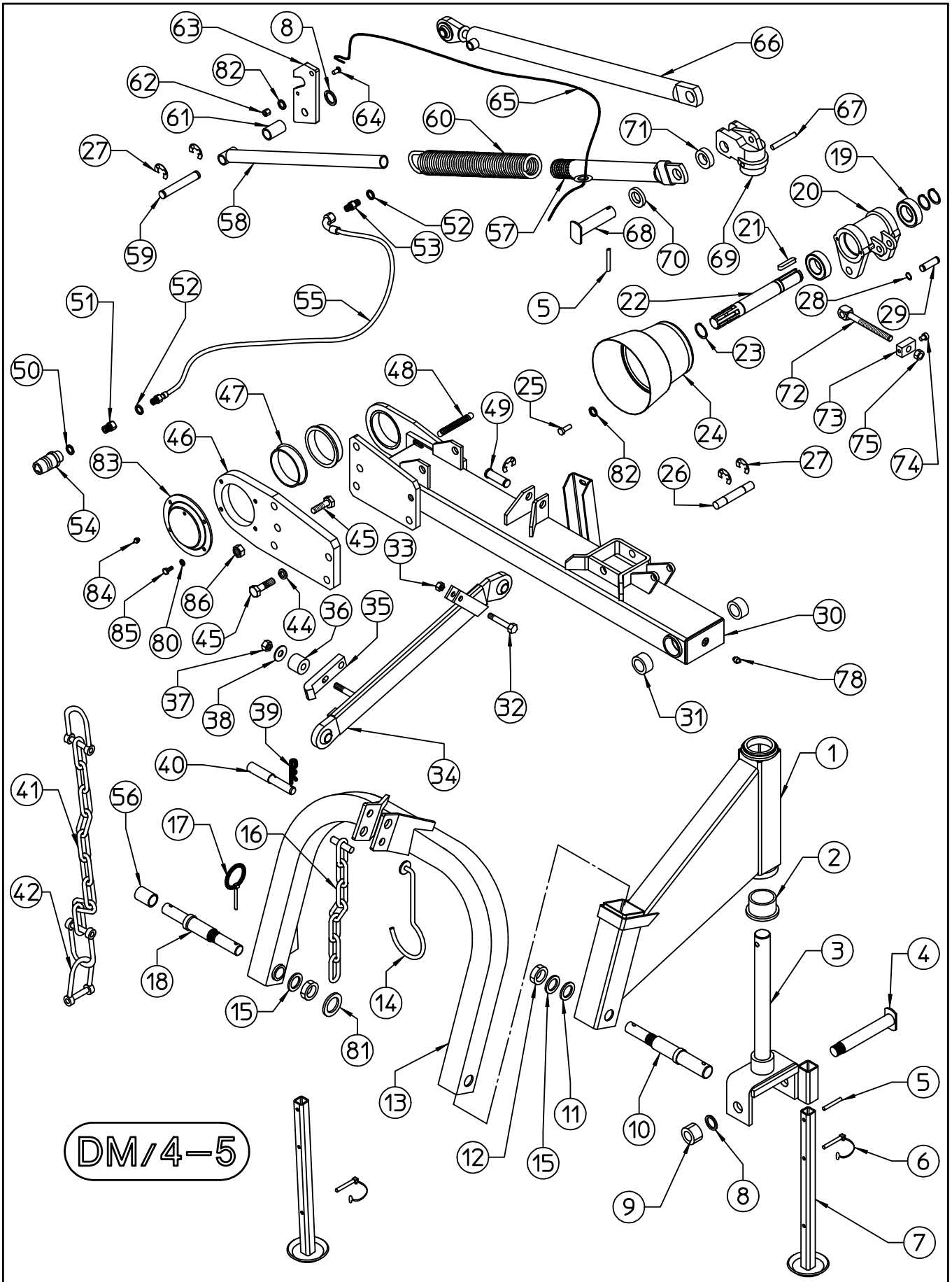

TABLE NO. 910.036 DM/4-5

ITEM	Q.ty	PART/NO	DESCRIPTION	NOTE	ITEM	Q.ty	PART/NO	DESCRIPTION	NOTE
1	1	100.162	SUPPORT		42	3	610.118	SHACKLES	
2	1	100.236	BUSH		**	**	*****	*****	
3	1	100.163	PIN SUPPORT		44	1	600.180	WASHER	
4	1	100.164	PIN		45	5	620.361	SCREW M16x60	
5	3	600.027	SPRING PIN		46	1	110.407	BOX SUPPORT	
6	2	610.186	PIN		47	2	100.831	BUSH	
7	2	100.166	PARKING STAND		48	1	100.235	SPRING	
8	2	600.632	WASHER		49	1	100.176	PIN	
9	1	600.717	NUT		*	1	100.203	KIT HYDRAULIC	
10	1	100.175	PIN		50	1	600.269	COPPER WASHER	
11	1	600.336	WASHER		51	1	600.428	NIPPLE	
12	2	610.150	NUT		52	3	600.039	COPPER WASHER	
13	1	100.161	3 POINT HITCH		53	1	200.192	NIPPLE	
14	1	100.253	SUPPORT		54	1	600.273	QUICK COUPLING	
15	2	600.246	WASHER		55	1	610.143	HOSE	
16	1	110.368	CHAIN		56	1	400.045/a	BUSH	
17	3	600.017	PIN		57	1	100.170/a	OUTER TUBE	
18	1	100.280	PIN		58	1	100.171	INNER TUBE	
19	2	600.608	BEARING		59	1	100.202	PIN	
20	1	100.756	SUPPORT		60	1	100.172	SPRING	
21	1	610.153	TAB	DM/4	61	1	100.204	BUSH	
21	1	610.154	TAB	DM/5	62	1	600.076	NUT	
22	1	100.760	P.T.O. SHAFT	DM/4	63	1	110.029	HOOK	
22	1	100.761	P.T.O. SHAFT	DM/5	64	1	110.053	SCREW	
23	4	600.333	SNAP RING		65	1	610.160	ROPE	
24	1	620.442	HOOD		66	1	100.169	CYLINDER	
25	2	600.650	SCREW		67	1	610.168	SPRING PIN	
26	1	100.757	PIN		68	1	100.173	PIN	
27	5	610.152	SNAP RING		69	1	100.165	UPPER SUPPORT	
28	2	600.533	SNAP RING		70	1	100.251	BUSH	
29	1	100.758	PIN		71	1	100.252	BUSH	
30	1	110.409	MAIN FRAME		72	1	100.746	TIE ROD	
31	2	100.198/a	BUSH		73	1	100.745	SUPPORT	
32	1	600.754	SCREW		74	2	610.941	SCREW	
33	1	600.077	NUT		75	2	600.032	SCREW	
34	1	100.167/a	SAFETY HOOK		78	2	600.124	GREASE NIPPLE	
35	1	100.168	HOOK		80	4	600.514	WASHER	
36	1	100.201	SPRING		81	1	200.165	WASHER	
37	1	600.075	NUT		82	3	610.185	WASHER	
38	1	610.231	WASHER		83	1	110.411	COVER	
39	1	600.308	SPLIT PIN		84	1	600.034	GREASE NIPPLE	
40	1	200.343	PIN		85	4	600.236	SCREW	
41	1	110.367	CHAIN		86	4	630.407	NUT M16	

TABLE NO. 910.030

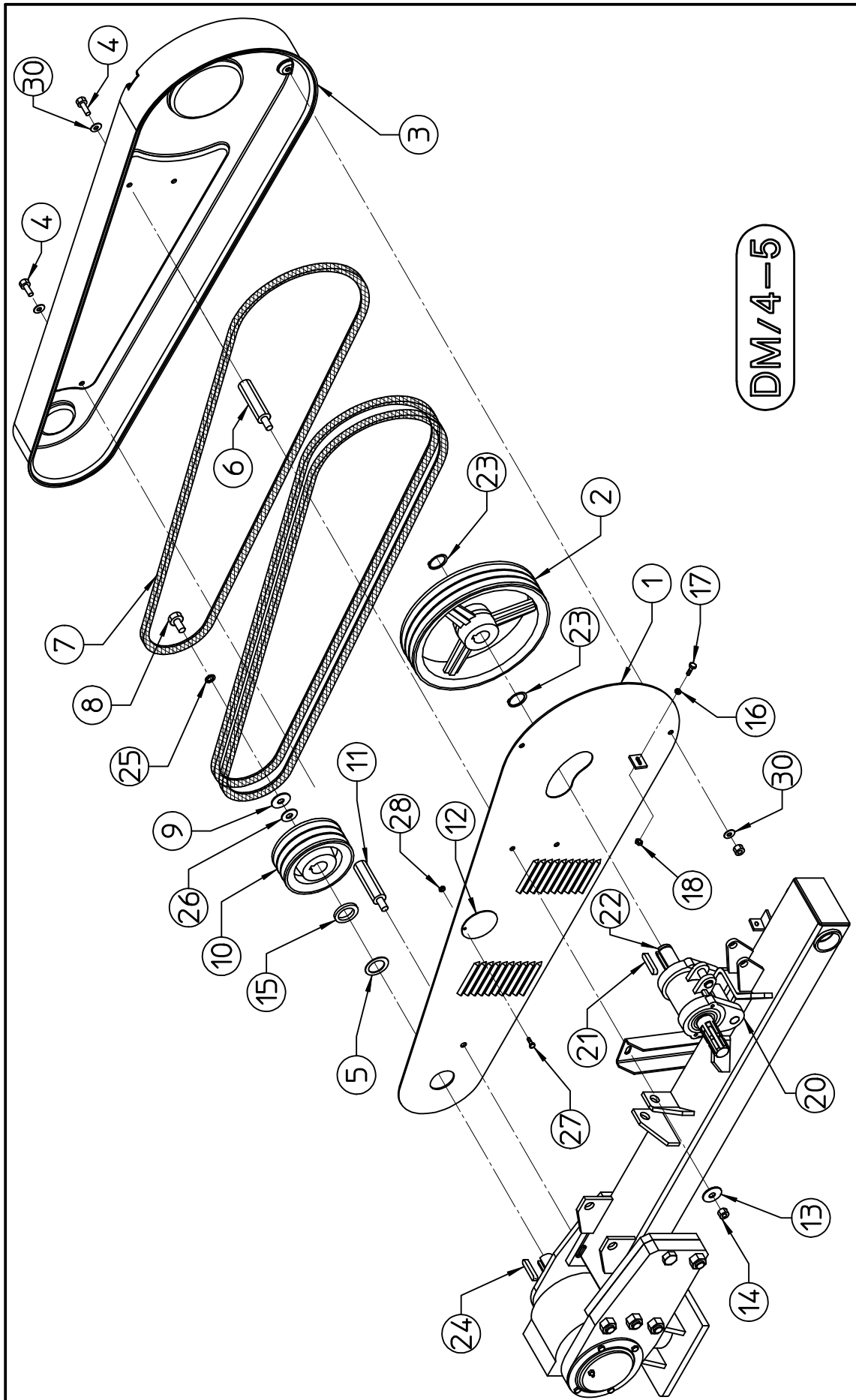

TABLE NO. 910.030				
DM/4-5				
ITEM	Q.ty	PART/NO	DESCRIPTION	NOTE
1	1	100.918	INTERNAL COVER	
2	1	100.180	PULLEY	DM/4
2	1	100.224	PULLEY	DM/5
3	1	100.919	OUTER COVER	
4	5	600.227	SCREW M10x20	
5	1	200.475	SPACER SCREW	
6	4	100.921	SPACER SCREW	
7	3	610.033	BELT	DM/4
7	4	610.033	BELT	DM/5
8	1	630.015	SCREW	
9	1	500.160	WASHER	
10	1	100.181	PULLEY	DM/4
10	1	100.225	PULLEY	DM/5
11	1	100.920	SPACER SCREW	
12	1	100.313	PLUG	
13	2	600.092	WASHER	
14	4	600.029	NUT M10	
15	1	100.205	BUSH	
16	1	610.185	WASHER D.9	
17	1	600.702	SCREW M8x25	
18	1	600.076	NUT M8	
20	1	100.756	SUPPORT	
21	1	610.153	TAB	DM/4
21	1	610.154	TAB	DM/5
22	1	100.760	P.T.O. SHAFT	DM/4
22	1	100.761	P.T.O. SHAFT	DM/5
23	2	600.333	SNAP RING	
24	1	610.505	TAB	
25	1	600.018	WASHER	
26	1	220.864	WASHER	DM/4
27	1	620.275	SCREW M4x16	
28	1	610.718	NUT M4	
30	7	600.322	WASHER	

TABLE NO. 910.038

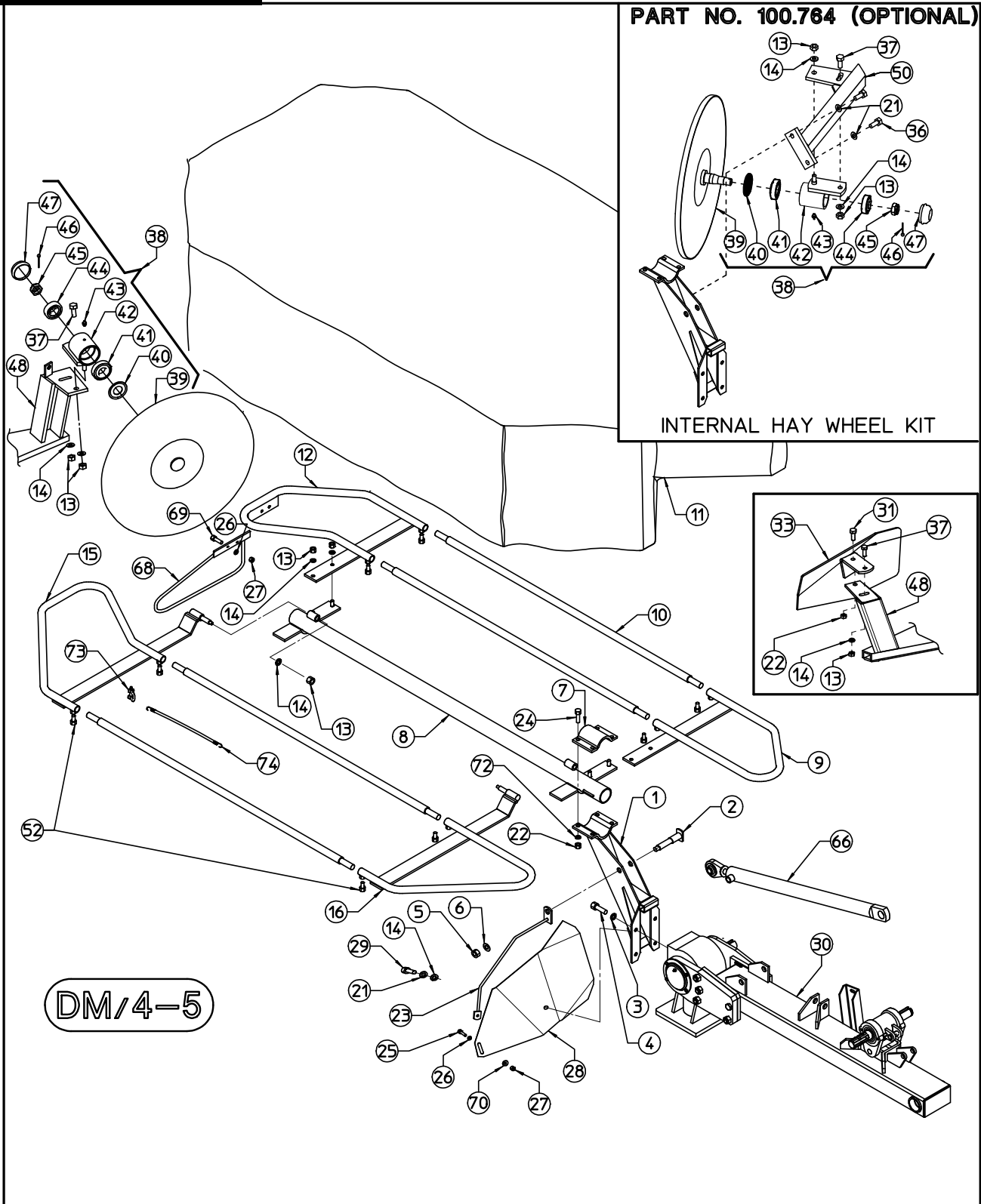

TABLE NO. 910.038				
DM/4-5				
ITEM	Q.ty	PART/NO	DESCRIPTION	NOTE
1	1	100.190/a	SUPPORT	
2	1	100.174/a	PIN	
3	4	600.018	WASHER	
4	4	620.788	SCREW	
5	1	600.080	NUT	
6	1	600.031	WASHER	
7	1	100.192	OUTER SUPPORT	
8	1	100.191/a	FRAME TUBE	DM/4
8	1	100.937	FRAME TUBE	DM/5
9	1	100.194/a	FRAME	
10	4	100.197/a	DISTANCE TUBE	DM/4
10	4	100.256/a	DISTANCE TUBE	DM/5
11	1	100.244	PROTECTION CANVAS	DM/4
11	1	100.245	PROTECTION CANVAS	DM/5
12	1	110.402	FRAME	
13	7	600.029	NUT	
14	8	600.322	WASHER	
15	1	100.195/a	FRAME	
16	1	100.196/a	FRAME	
21	1	600.024	WASHER	
22	5	600.077	NUT	
23	1	100.328	ARM	
24	4	600.754	SCREW	
25	1	600.757	SCREW	
26	3	600.115	WASHER	
27	3	600.076	NUT	
28	1	100.188	PLATE DEFLECTOR	
29	1	600.148	SCREW	
31	1	600.616	SCREW M12 x 35	
33	1	110.378	CONVEYOR	
36	2	600.006	SCREW	
37	1	600.641	SCREW	
38	1	100.763	HAY WHEEL ASSY	
39	1	100.881	HAY WHEEL	
40	1	600.011	DUST COVER	
41	1	600.012	BEARING 30205	
42	1	100.569	HUB	
43	1	600.124	GREASE NIPPLE	
44	1	600.014	BEARING 30204	
45	1	600.015	NUT	
46	1	600.301	SPLIT PIN	
47	1	205.654	CUP	
48	1	110.392	SUPPORT	
50	1	100.766	SUPPORT	
52	8	600.227	SCREW	
66	1	100.169	CYLINDER	
68	1	110.401	SUPPORT	
69	2	600.702	SCREW M8x25	
70	1	610.185	WASHER ø9/24x2	
72	4	600.089	WASHER	
73	4	600.761	"D" SHACKLE	
74	2	110.048	ELASTIC	
-	1	100.764	INTERNAL HAY WHEEL KIT	OPTIONAL

TABLE NO. 910.037

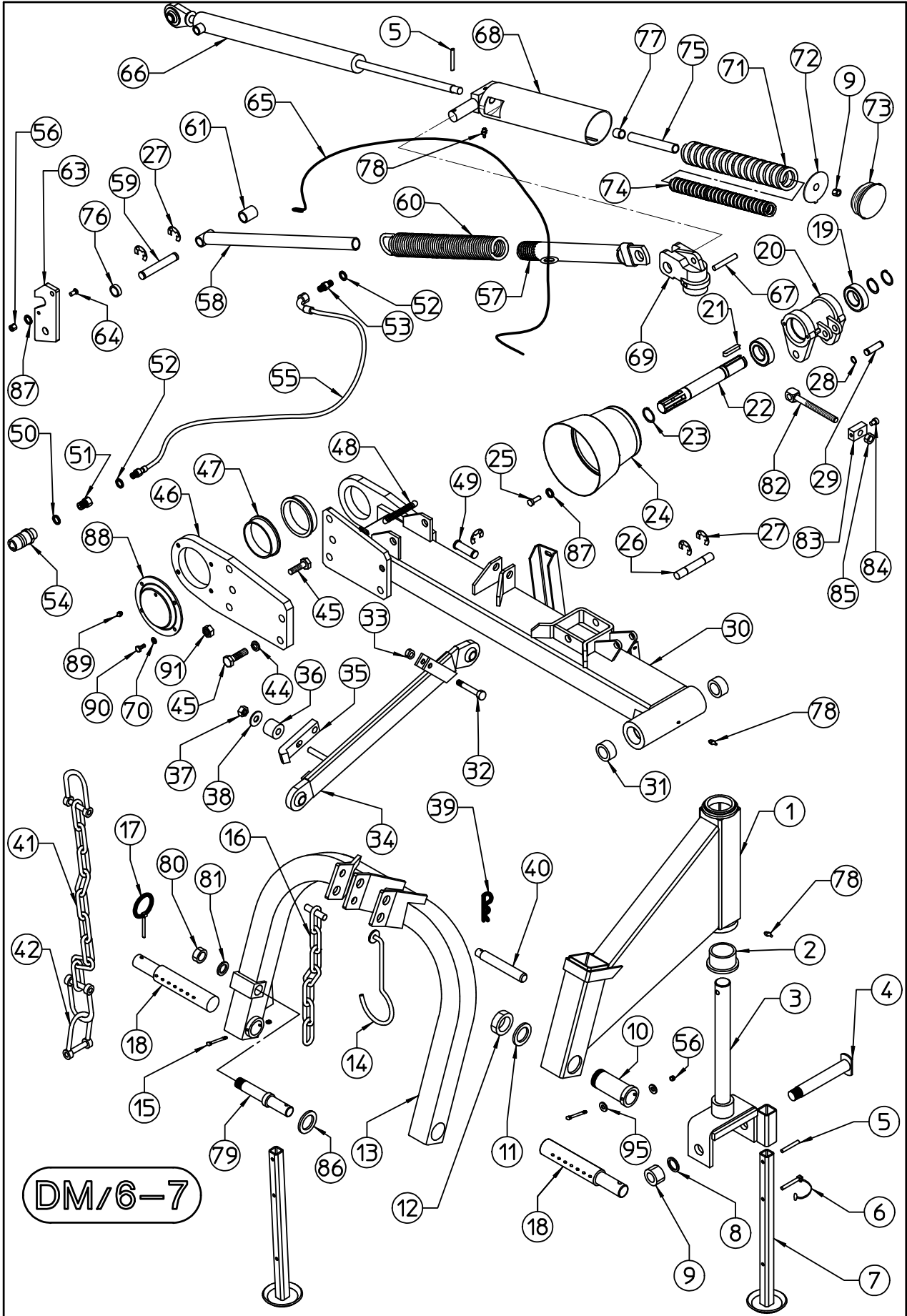

TABLE NO. 910.037 DW/ 6-7									
ITEM	Q.ty	PART/NO	DESCRIPTION	NOTE	ITEM	Q.ty	PART/NO	DESCRIPTION	NOTE
1	1	100.319	SUPPORT		47	2	100.831	BUSH	
2	1	100.236	BUSH		48	1	100.235	SPRING	
3	1	100.221/a	PIN SUPPORT		49	1	100.176	PIN	
4	1	100.222/a	PIN		50	1	600.269	COPPER WASHER	
5	3	600.027	SPRING PIN		51	1	600.428	NIPPLE	
6	2	610.186	PIN		52	3	600.039	COPPER WASHER	
7	2	100.166	PARKING STAND		53	1	200.192	NIPPLE	
8	2	600.632	WASHER		54	1	600.273	QUICK COUPLING	
9	2	600.717	NUT		55	1	610.143	HOSE	
10	1	100.322	BUSH		56	3	600.076	NUT	
11	1	100.324	WASHER		57	1	100.223/a	OUTER TUBE	
12	2	610.316	NUT		58	1	100.171	INNER TUBE	
13	1	100.563	3 POINT HITCH		59	1	100.202	PIN	
14	1	100.253	SUPPORT		60	1	100.172	SPRING	
15	2	600.400	SCREW		61	1	100.365	BUSH	
16	1	110.368	CHAIN		*	1	100.203	KIT HYDRAULIC	
17	3	600.017	PIN		63	1	110.029	HOOK	
18	2	100.320	PIN		64	1	110.053	SCREW	
19	2	600.608	BEARING		65	1	610.160	ROPE	
20	1	100.756	SUPPORT		66	1	100.214	CYLINDER	
21	2	610.154	TAB		67	1	610.168	SPRING PIN	
22	1	100.761	P.T.O. SHAFT		68	1	110.372	SUPPORT	
23	4	600.333	SNAP RING		69	1	100.165	UPPER SUPPORT	
24	1	620.442	HOOD		70	4	600.514	WASHER	
25	2	600.650	SCREW		71	1	110.373	SPRING	
26	1	100.757	PIN		72	1	110.375	FLANGE	
27	5	610.152	SNAP RING		73	1	630.327	PLUG	
28	2	600.533	SNAP RING		74	1	110.374	SPRING	ONLY DM/7
29	1	100.758	PIN		75	1	100.217	BUSH	
30	1	110.408	MAIN FRAME		76	1	100.363	BUSH	
31	2	100.232	BUSH		77	1	100.362	BUSH	
32	1	600.754	SCREW		78	3	600.124	GREASE NIPPLE	
33	1	600.077	NUT		79	1	100.564	PIN	
34	1	100.167/a	SAFETY HOOK		80	1	600.244	NUT	
35	1	100.168	HOOK		81	1	600.246		
36	1	100.201	SPRING		82	1	100.746	TIE ROD	
37	1	600.075	NUT		83	1	100.745	SUPPORT	
38	1	610.231	WASHER		84	2	610.941	SCREW	
39	1	600.308	SPLIT PIN		85	2	600.032	NUT	
40	1	100.321	PIN		86	1	200.165	WASHER	
41	1	110.367	CHAIN		87	3	610.185	WASHER	
42	3	610.118	SHACKLES		88	1	110.411	COVER	
***	***	*****	*****		89	1	600.034	GREASE NIPPLE	
44	1	600.180	WASHER		90	2	600.236	SCREW	
45	5	620.361	SCREW M16x60		91	4	630.407	NUT M16	
46	1	110.407	BOX SUPPORT		95	4	600.115	WASHER	

TABLE NO. 910.032

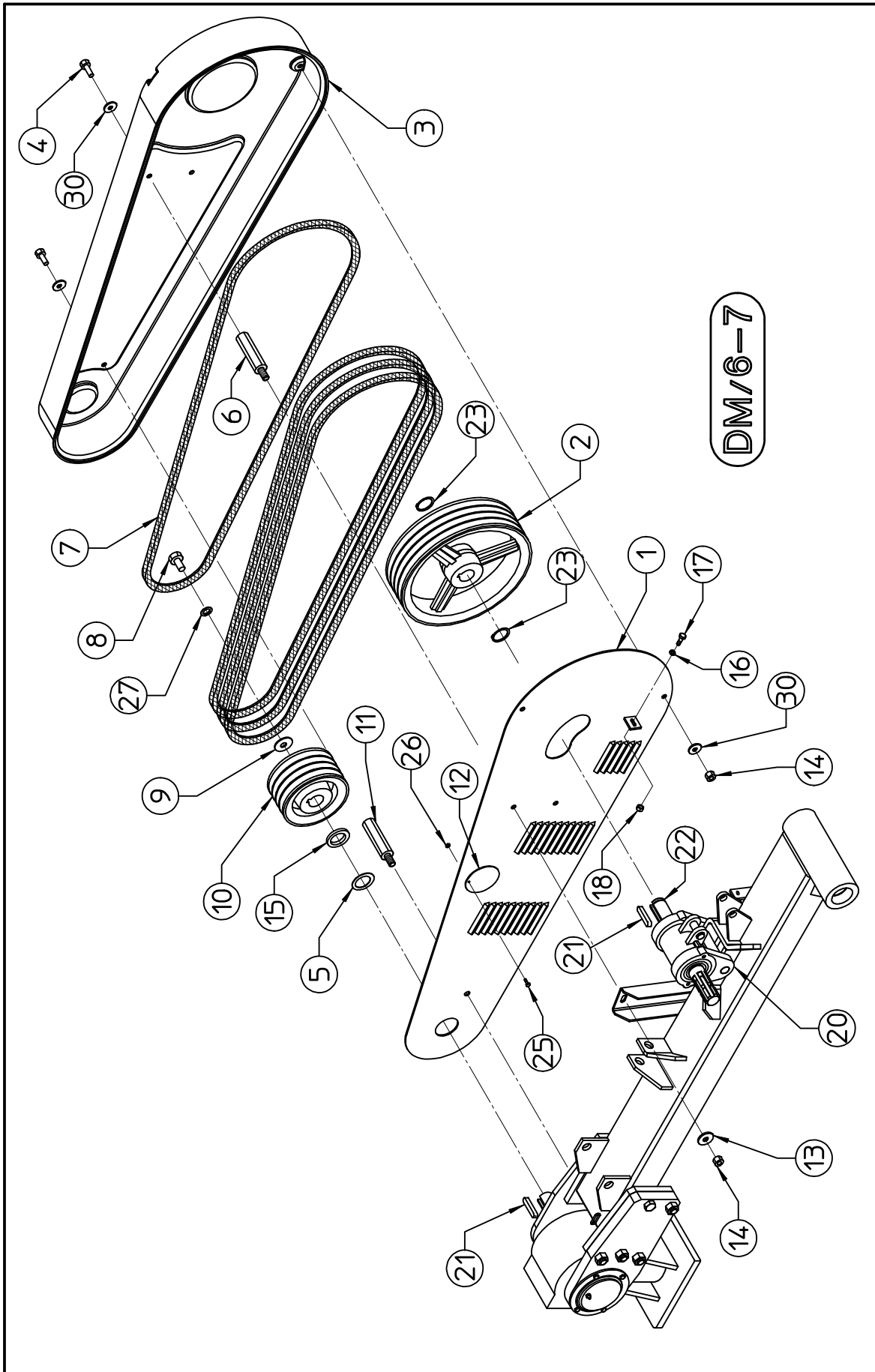

TABLE NO. 910.032				
DM/6-7				
ITEM	Q.ty	PART/NO	DESCRIPTION	NOTE
1	1	100.916	INTERNAL COVER	
2	1	100.224	PULLEY	
3	1	100.917	OUTER COVER	
4	5	600.227	SCREW M10x20	
5	1	200.475	SPACER SCREW	
6	4	100.921	SPACER SCREW	
7	4	610.032	BELT	
8	1	630.015	SCREW M12x40	
9	2	500.160	WASHER	
10	1	100.225	PULLEY	
11	1	100.920	SPACER SCREW	
12	1	100.313	PLUG	
13	2	600.092	WASHER	
14	4	600.029	NUT M10	
15	1	100.205	BUSH	
16	1	610.185	WASHER	
17	1	600.702	SCREW M8x25	
18	1	600.076	NUT M8	
20	1	100.756	SUPPORT	
21	1	610.154	TAB	
22	1	100.761	P.T.O. SHAFT	
23	2	600.333	SNAP RING	
24	1	610.505	TAB	
25	1	620.275	SCREW M4x16	
26	1	610.718	NUT M4	
27	1	600.018	WASHER	
30	7	600.322	WASHER	

TABLE NO. 910.039

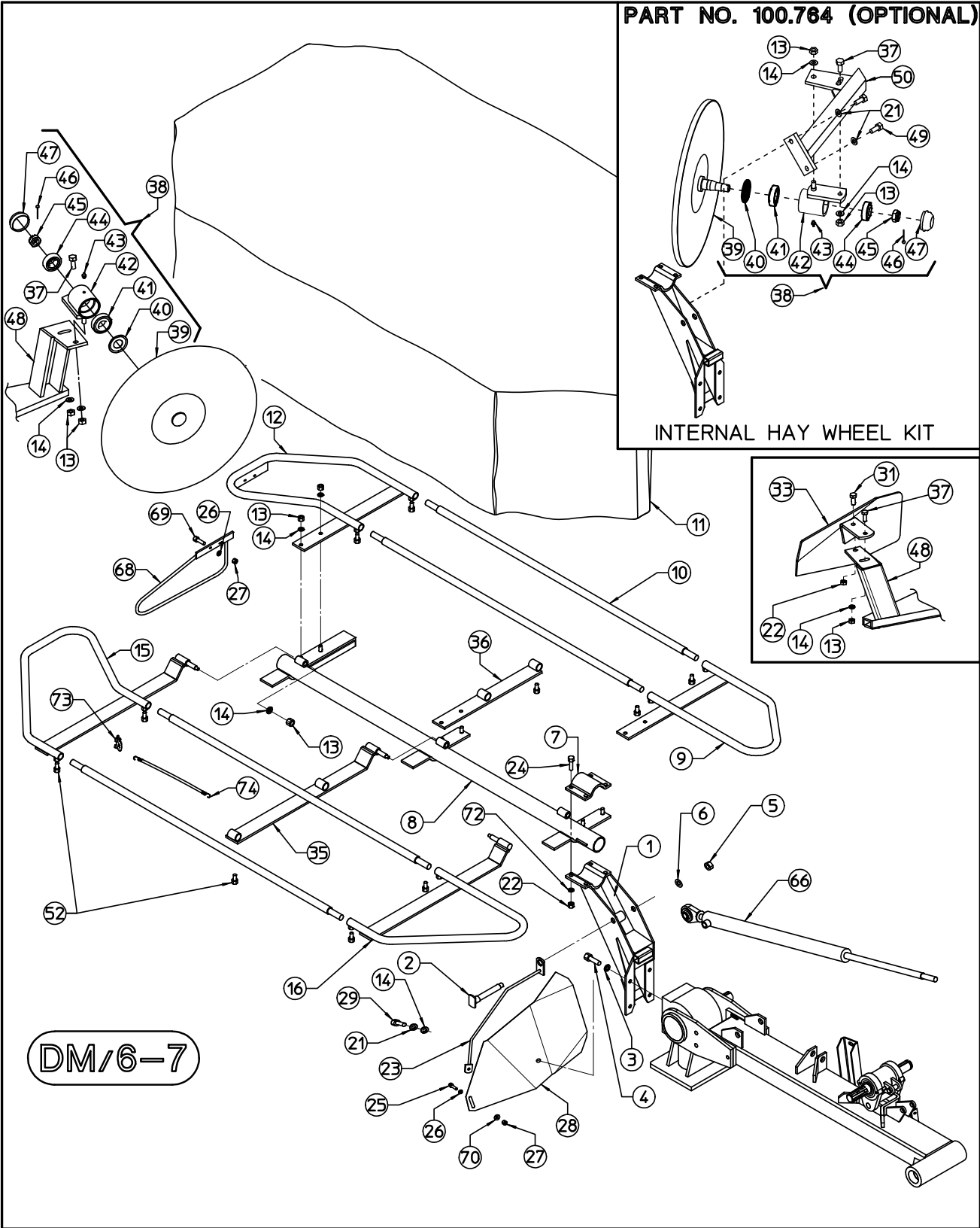

TABLE NO. 910.039 DM/6-7				
ITEM	Q.ty	PART/NO	DESCRIPTION	NOTE
1	1	100.360	SUPPORT	
2	1	100.361	PIN	
3	4	600.018	WASHER	
4	4	620.788	SCREW	
5	1	600.080	NUT	
6	1	600.031	WASHER	
7	1	100.192	OUTER SUPPORT	
8	1	100.938	FRAME TUBE	DM/6
8	1	100.939	FRAME TUBE	DM/7
9	1	100.194/a	FRAME	
10	4	100.231/a	DISTANCE TUBE	DM/6
10	4	100.257	DISTANCE TUBE	DM/7
11	1	100.246	PROTECTION CANVAS	DM/6
11	1	100.247	PROTECTION CANVAS	DM/7
12	1	110.402	FRAME	
13	10	600.029	NUT	
14	11	600.322	WASHER	
15	1	100.195/a	FRAME	
16	1	100.196/a	FRAME	
21	1	600.024	WASHER	
22	5	600.077	NUT	
23	1	100.515	ARM	
24	4	600.754	SCREW	
25	1	600.757	SCREW	
26	3	600.115	WASHER	
27	3	600.076	NUT	
28	1	100.188	PLATE DEFLECTOR	
28	1	100.329	PLATE DEFLECTOR	DM/7
29	1	600.148	SCREW	
31	1	600.616	SCREW	
32	1	600.077	NUT	
33	1	110.378	CONVEYOR	
35	1	100.325/a	FRAME	DM/7
36	1	100.326/a	FRAME	DM/7
37	1	600.641	SCREW	
38	1	100.763	HAY WHEEL ASSY	
39	1	100.881	HAY WHEEL	
40	1	600.011	DUST COVER	
41	1	600.012	BEARING 30205	
42	1	100.569	HUB	
43	1	600.124	GREASE NIPPLE	
44	1	600.014	BEARING 30204	
45	1	600.015	NUT	
46	1	600.301	SPLIT PIN	
47	1	205.654	CUP	
48	1	110.392	SUPPORT	DM/6
48	1	110.405	SUPPORT	DM/7
49	2	600.006	SCREW	
50	1	100.766	SUPPORT	
52	12	600.227	SCREW	
66	1	100.214	CYLINDER	
68	1	110.401	SUPPORT	
69	2	600.702	SCREW M8x25	
70	1	610.185	WASHER \varnothing 9/24x2	
72	4	600.089	WASHER	
73	4	600.761	"D" SHACKLE	
74	2	110.048	ELASTIC	
-	1	100.764	INTERNAL HAY WHEEL KIT	OPTIONAL

TABLE NO. 910.041/b

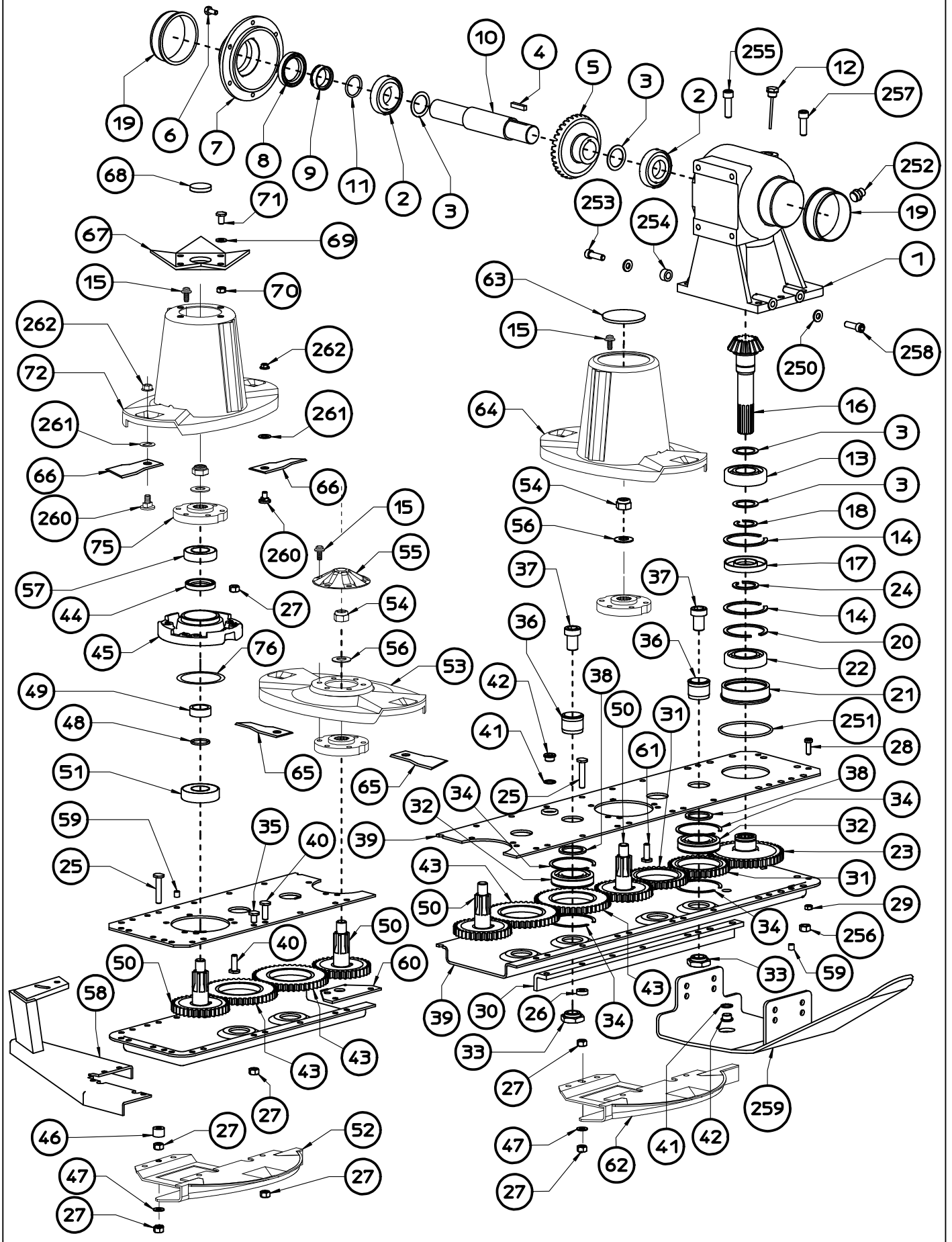

TABLE NO. 910.041/b				
DM-4				
ITEM	Q.TY	PART/NO	DESCRIPTION	NOTE
1	1	100.882	GEAR BOX CASING	
2	2	620.129	BEARING	
3	4	100.883	WASHER	
4	1	620.141	TAB	
5	1	100.772	BEVEL GEAR	
6	8	620.130	SCREW	
7	1	100.770	COVER	
8	1	620.156	OIL SEAL	
9	1	100.884	BUSH	
10	1	100.771	DRIVING SHAFT	
11	1	620.171	RING OR	
12	1	100.774	PLUG	
13	1	620.172	BEARING	
14	2	620.148	SNAP RING	
15	24	620.244	SCREW	
16	1	100.773	SPROCKET	
17	1	620.161	SEAL	
18	1	620.145	RING	
19	2	100.831	BUSH	
20	1	620.148	SNAP RING	
21	1	100.885	BEARING BUSH	
22	1	620.173	BEARING	
23	1	100.779	GEAR	
24	1	620.146	SNAP RING	
25	4	100.783	SCREW	
26	1	100.792	DISTANCE	
27	70	620.136	NUT	
28	4	620.131	SCREW	
29	4	620.174	NUT	
30	1	100.892	REAR REINFORCEMET	
31	2	100.801	GEAR	
32	8	620.126	BEARING	
33	8	100.798	NUT	
34	16	100.804	SNAP RING	
35	21	100.787	SCREW	
36	8	100.797	DISTANCE PIN	
37	8	100.786	SCREW	
38	8	100.785	DISTANCE	
39	1	100.889	SUPPORT (UPPER+LOWER)	
40	40	100.782	SCREW	
41	3	620.175	WASHER	
42	3	100.789	PLUG	
43	6	100.802	GEAR	
44	4	620.159	SEAL	
45	4	110.418	DISC SUPPORT	
46	3	100.793	DISTANCE	

TABLE NO. 910.041/b				
DM-4				
ITEM	Q.TY	PART/NO	DESCRIPTION	NOTE
47	4	100.795	WASHER	
48	4	620.165	RING OR	
49	4	100.803	BUSH	
50	4	100.800	GEAR	
51	4	620.176	BEARING	
52	3	100.995	SUPPORT	
53	2	100.994	DISC	
54	4	620.139	NUT	
55	2	100.996	COVER	
56	4	620.150	WASHER	
57	4	620.128	BEARING	
58	1	110.392	SUPPORT DEFLEKTOR	
59	2	620.143	SPRING PIN	
60	1	100.890	HOOK	
61	1	100.790	SCREW	
62	1	110.001	SUPPORT	
63	2	100.791	PLUG	
64	2	110.002	DISC CONVEY	
65	4	110.118	CLOCK-WISE KNIFE	
66	4	110.119	CONTERCLOCK-WISE KNIFE	
67	1	100.332	DISC CONVEY PLATE	
68	1	500.056	PLUG	
69	4	600.115	WASHER	
70	4	600.076	NUT	
71	4	600.223	SCREW	
72	1	110.002	DISC CONVEY	
75	4	100.993	SUPPORT	
76	4	630.576	RING OR	
250	4	600.322	WASHER	
251	1	620.164	RING OR	
252	1	620.152	PLUG	
253	2	600.641	SCREW	
254	2	100.788	SPACER	
255	3	620.132	SCREW	
256	8	620.137	NUT	
257	5	620.133	SCREW	
258	2	600.227	SCREW	
259	1	100.891	SUPPORT	
260	8	100.796	SCREW	
261	8	100.821	WASHER	
262	8	100.794	NUT	

TABLE NO. 910.042/c

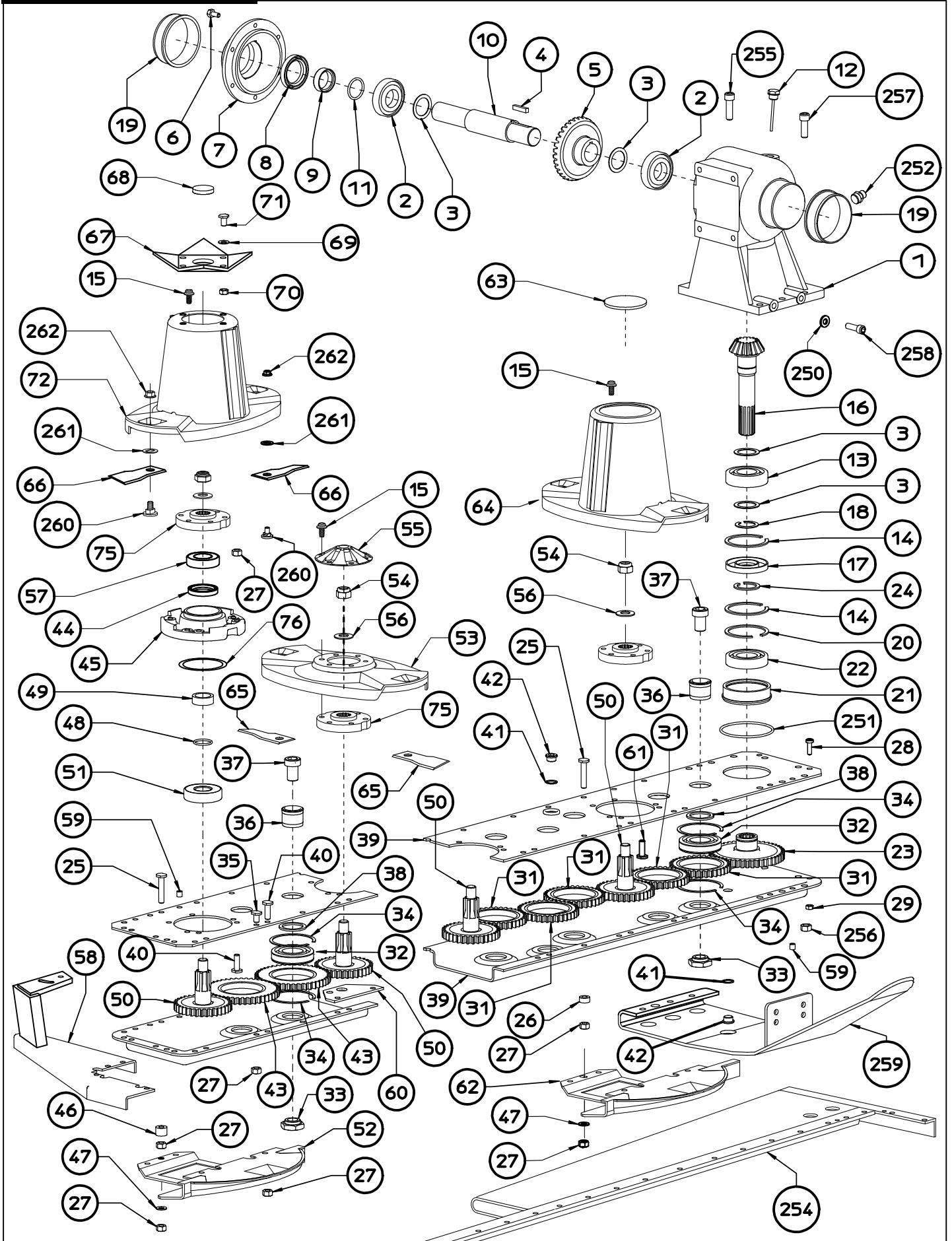

TABLE NO. 910.042/c				
DM-5				
ITEM	Q.TY	PART/NO	DESCRIPTION	NOTE
1	1	100.882	GEAR BOX CASING	
2	2	620.129	BEARING	
3	4	100.883	WASHER	
4	1	620.141	TAB	
5	1	100.772	BEVEL GEAR	
6	8	620.130	SCREW	
7	1	100.770	COVER	
8	1	620.156	OIL SEAL	
9	1	100.884	BUSH	
10	1	100.771	DRIVING SHAFT	
11	1	620.171	RING OR	
12	1	100.774	PLUG	
13	1	620.172	BEARING	
14	2	620.148	SNAP RING	
15	30	620244	SCREW	
16	1	100.773	SPROCKET	
17	1	620.161	SEAL	
18	1	620.145	RING	
19	2	100.831	BUSH	
20	1	620.148	SNAP RING	
21	1	100.885	BEARING BUSH	
22	1	620.173	BEARING	
23	1	100.779	GEAR	
24	1	620.146	SNAP RING	
25	5	100.783	SCREW	
26	3	100.792	DISTANCE	
27	86	620.136	NUT	
28	4	620.131	SCREW	
29	4	620.174	NUT	
30	1	110.397	REAR REINFORCEMET	
31	5	100.801	GEAR	
32	11	620.126	BEARING	
33	11	100.798	NUT	
34	11	100.804	SNAP RING	
35	21	100.787	SCREW	
36	11	100.797	DISTANCE PIN	
37	11	100.786	SCREW	
38	11	100.785	DISTANCE	
39	1	100.888	SUPPORT (UPPER+LOWER)	
40	49	100.782	SCREW	
41	3	620.175	WASHER	
42	3	100.789	PLUG	
43	6	100.802	GEAR	
44	5	620.159	SEAL	
45	5	110.418	DISC SUPPORT	
46	2	100.793	DISTANCE	

TABLE NO. 910.042/c				
DM-5				
ITEM	Q.TY	PART/NO	DESCRIPTION	NOTE
47	5	100.795	WASHER	
48	5	620.165	RING OR	
49	5	100.803	BUSH	
50	5	100.800	GEAR	
51	5	620.176	BEARING	
52	3	100.995	SUPPORT	
53	3	100.994	DISC	
54	5	620.139	NUT	
55	3	100.996	COVER	
56	5	620.150	WASHER	
57	5	620.128	BEARING	
58	1	110.392	SUPPORT DEFLEKTOR	
59	2	620.143	SPRING PIN	
60	1	100.890	HOOK	
61	6	100.790	SCREW	
62	2	110.001	SUPPORT	
63	2	100.791	PLUG	
64	2	110.002	DISC CONVEY	
65	4	110.118	CLOCK-WISE KNIFE	
66	6	110.119	CONTERCLOCK-WISE KNIFE	
67	1	100.332	DISC CONVEY PLATE	
68	1	500.056	PLUG	
69	4	600.115	WASHER	
70	4	600.076	NUT	
71	4	600.223	SCREW	
72	1	110.002	DISC CONVEY	
75	5	100.993	SUPPORT	
76	5	630.576	RING OR	
250	4	600.322	WASHER	
251	1	620.164	RING OR	
252	1	620.152	PLUG	
254	1	110.397	REINFORCEMENT	
255	3	620.243	SCREW	
256	8	620.137	NUT	
257	5	620.133	SCREW	
258	2	600.227	SCREW	
259	1	110.381	SUPPORT	
260	10	100.796	SCREW	
261	10	100.821	WASHER	
262	10	100.794	NUT	

TABLE NO. 910.043/c

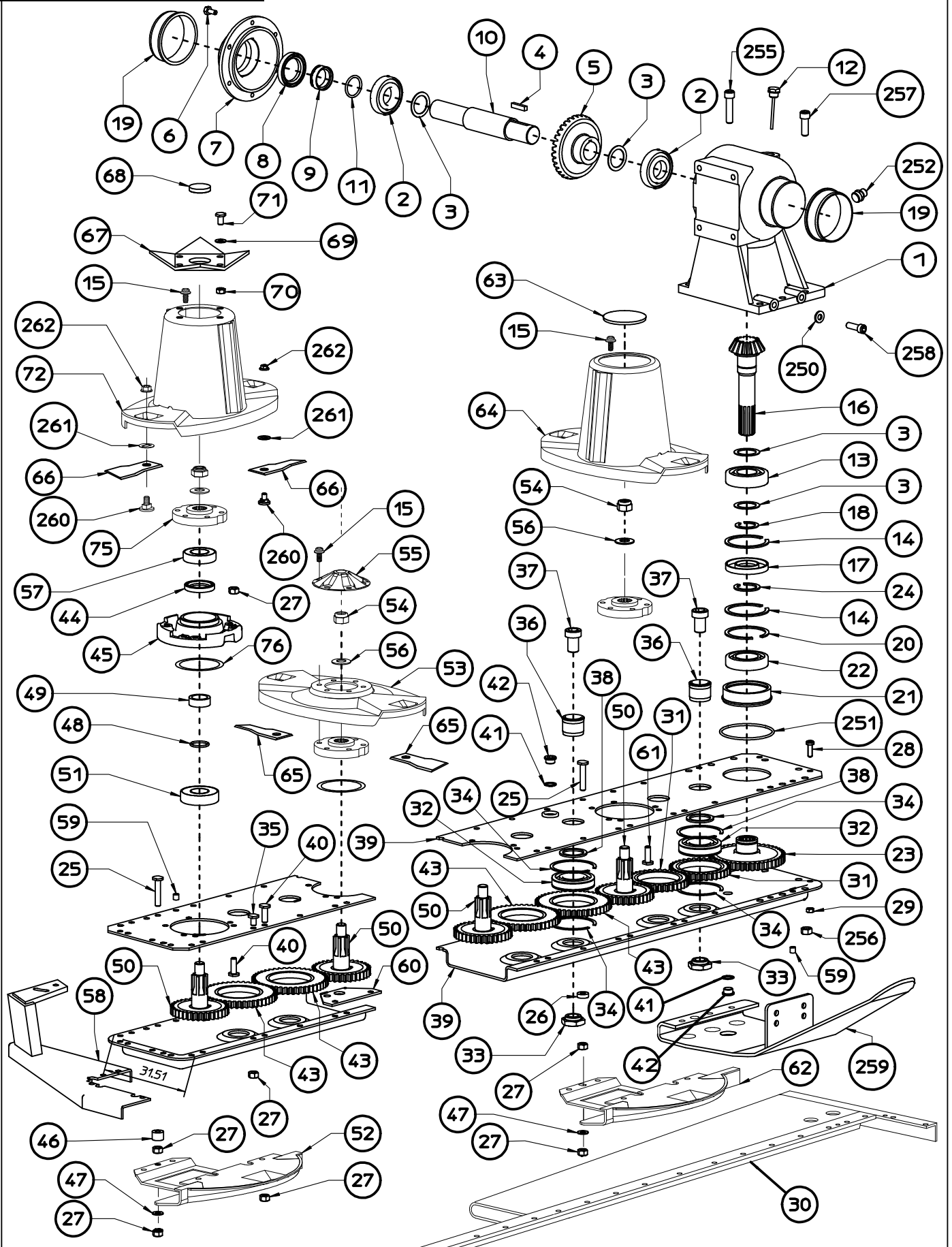

TABLE NO. 910.043/c				
DM-6				
ITEM	Q.TY	PART/NO	DESCRIPTION	NOTE
1	1	100.882	GEAR BOX CASING	
2	2	620.129	BEARING	
3	4	100.883	WASHER	
4	1	620.141	TAB	
5	1	100.772	BEVEL GEAR	
6	8	620.130	SCREW	
7	1	100.770	COVER	
8	1	620.156	OIL SEAL	
9	1	100.884	BUSH	
10	1	100.771	DRIVING SHAFT	
11	1	620.171	RING OR	
12	1	100.774	PLUG	
13	1	620.172	BEARING	
14	2	620.148	SNAP RING	
15	36	620.244	SCREW	
16	1	100.773	SPROCKET	
17	1	620.161	SEAL	
18	1	620.145	RING	
19	2	100.831	BUSH	
20	1	620.148	SNAP RING	
21	1	100.885	BEARING BUSH	
22	1	620.173	BEARING	
23	1	100.779	GEAR	
24	1	620.146	SNAP RING	
25	6	100.783	SCREW	
26	4	100.792	DISTANCE	
27	102	620.136	NUT	
28	4	620.131	SCREW	
29	4	620.174	NUT	
30	1	110.380	REAR REINFORCEMET	
31	2	100.801	GEAR	
32	12	620.126	BEARING	
33	12	100.798	NUT	
34	24	100.804	SNAP RING	
35	24	100.787	SCREW	
36	12	100.797	DISTANCE PIN	
37	12	100.786	SCREW	
38	12	100.785	DISTANCE	
39	1	100.887	SUPPORT (UPPER+LOWER)	
40	62	100.782	SCREW	
41	3	620.175	WASHER	
42	3	100.789	PLUG	
43	10	100.802	GEAR	
44	6	620.159	SEAL	
45	6	110.418	DISC SUPPORT	
46	2	100.793	DISTANCE	

TABLE NO. 910.043/c				
DM-6				
ITEM	Q.TY	PART/NO	DESCRIPTION	NOTE
47	6	100.795	WASHER	
48	6	620.165	RING OR	
49	6	100.803	BUSH	
50	6	100.800	GEAR	
51	6	620.176	BEARING	
52	5	100.995	SUPPORT	
53	4	100.994	DISC	
54	6	620.139	NUT	
55	4	100.996	COVER	
56	6	620.150	WASHER	
57	6	620.128	BEARING	
58	1	110.392	SUPPORT DEFLEKTOR	
59	2	620.143	SPRING PIN	
60	1	100.890	HOOK	
61	4	100.790	SCREW	
62	1	110.001	SUPPORT	
63	2	100.791	PLUG	
64	2	110.002	DISC CONVEY	
65	6	110.118	CLOCK-WISE KNIFE	
66	6	110.119	CONTERCLOCK-WISE KNIFE	
67	1	100.332	DISC CONVEY PLATE	
68	1	500.056	PLUG	
69	4	600.115	WASHER	
70	4	600.076	NUT	
71	4	600.223	SCREW	
72	1	110.002	DISC CONVEY	
75	6	100.993	SUPPORT	
76	6	630.576	RING OR	
250	4	600.322	WASHER	
251	1	620.164	RING OR	
252	1	620.152	PLUG	
255	3	620.243	SCREW	
256	8	620.137	NUT	
257	5	620.133	SCREW	
258	2	600.227	SCREW	
259	1	110.381	SUPPORT	
260	12	100.796	SCREW	
261	12	100.821	WASHER	
262	12	100.794	NUT	

TABLE NO. 910.044/c

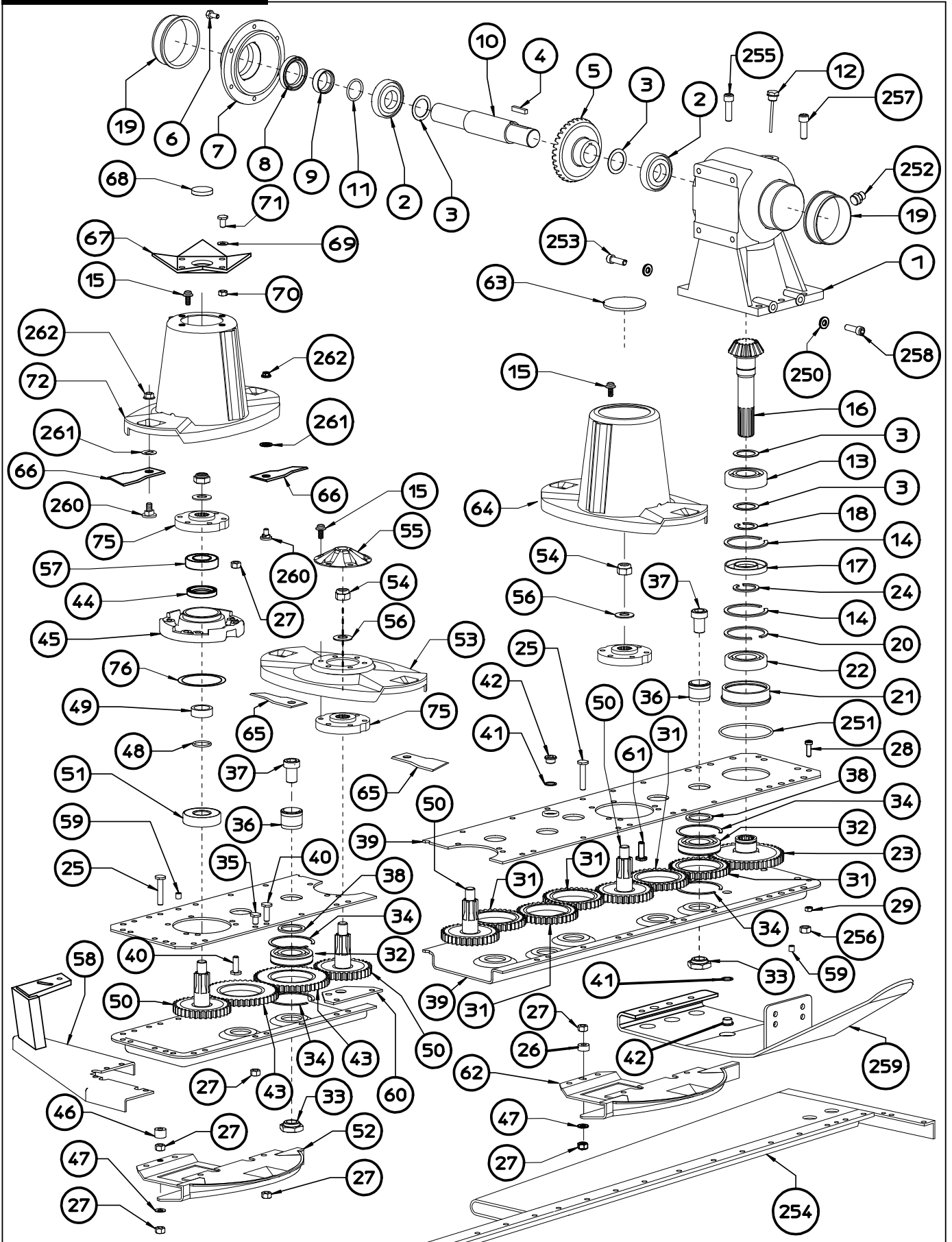
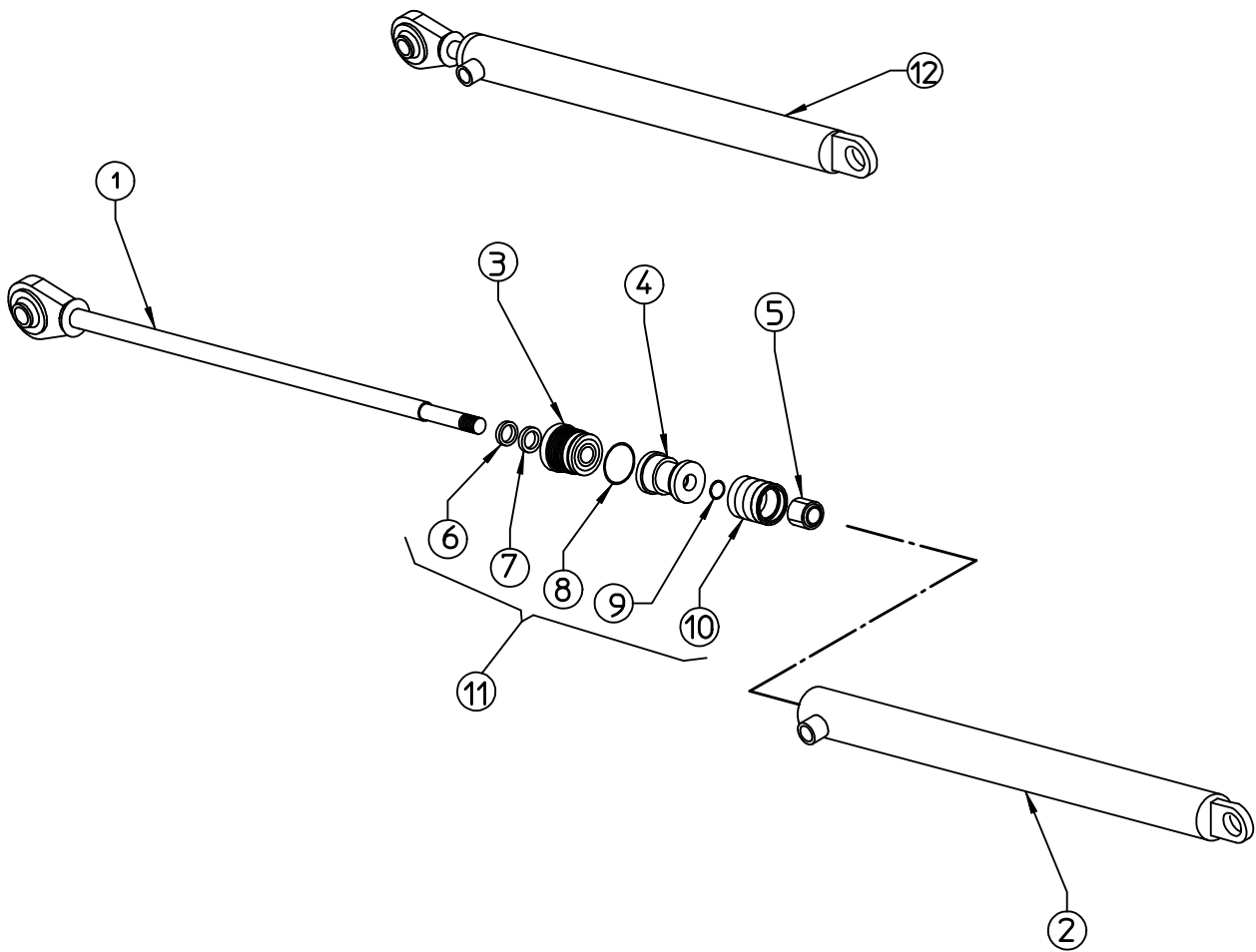

TABLE NO. 910.044/c				
DM-7				
ITEM	Q.TY	PART/NO	DESCRIPTION	NOTE
1	1	100.882	GEAR BOX CASING	
2	2	620.129	BEARING	
3	4	100.883	WASHER	
4	1	620.141	TAB	
5	1	100.772	BEVEL GEAR	
6	8	620.130	SCREW	
7	1	100.770	COVER	
8	1	620.156	OIL SEAL	
9	1	100.884	BUSH	
10	1	100.771	DRIVING SHAFT	
11	1	620.171	RING OR	
12	1	100.774	PLUG	
13	1	620.172	BEARING	
14	2	620.148	SNAP RING	
15	42	620.244	SCREW	
16	1	100.773	SPROCKET	
17	1	620.161	SEAL	
18	1	620.145	RING	
19	2	100.831	BUSH	
20	1	620.148	SNAP RING	
21	1	100.885	BEARING BUSH	
22	1	620.173	BEARING	
23	1	100.779	GEAR	
24	1	620.146	SNAP RING	
25	7	100.783	SCREW	
26	4	100.792	SCREW	
27	118	620.136	NUT	
28	4	620.131	SCREW	
29	4	620.174	NUT	
30	2	100.791	PLUG	
31	5	100.801	GEAR	
32	15	620.126	BEARING	
33	15	100.798	NUT	
34	30	100.804	SNAP RING	
35	31	100.787	SCREW	
36	15	100.797	DISTANCE PIN	
37	15	100.786	SCREW	
38	15	100.785	DISTANCE	
39	1	100.886	SUPPORT (UPPER+LOWER)	
40	71	100.782	SCREW	
41	3	620.175	WASHER	
42	3	100.789	PLUG	
43	10	100.802	GEAR	
44	7	620.159	SEAL	
45	7	110.418	DISC SUPPORT	
46	6	100.793	DISTANCE	

TABLE NO. 910.044/c				
DM-7				
ITEM	Q.TY	PART/NO	DESCRIPTION	NOTE
47	7	100.795	WASHER	
48	7	620.165	RING OR	
49	7	100.803	BUSH	
50	7	100.800	GEAR	
51	7	620.176	BEARING	
52	5	100.995	SUPPORT	
53	5	100.994	DISC	
54	7	620.139	NUT	
55	5	100.996	COVER	
56	7	620.150	WASHER	
57	7	620.128	BEARING	
58	1	110.405	SUPPORT DEFLEKTOR	
59	2	620.143	SPRING PIN	
60	1	100.890	HOOK	
61	7	100.790	SCREW	
62	2	110.001	SUPPORT	
64	2	110.002	DISC CONVEY	
65	6	110.118	CLOCK-WISE KNIFE	
66	8	110.119	CONTERCLOCK-WISE KNIFE	
67	1	100.332	DISC CONVEY PLATE	
68	1	500.056	PLUG	
69	4	600.115	WASHER	
70	4	600.076	NUT	
71	4	600.223	SCREW	
72	1	110.002	DISC CONVEY	
75	7	100.993	SUPPORT	
76	7	630.576	RING OR	
250	4	600.322	WASHER	
251	1	620.164	RING OR	
252	1	620.152	PLUG	
254	1	110.379	REAR REINFORCEMENT	
255	3	620.243	SCREW	
256	8	620.137	NUT	
257	5	620.133	SCREW	
258	2	600.227	SCREW	
259	1	110.381	SUPPORT	
260	14	100.796	SCREW	
261	14	100.821	WASHER	
262	14	100.794	NUT	

TABLE NO. 100.169

DM/4-5 CYLINDER PART. NO 100.169



12	100.169	1	CYLINDER DIA.40 mm COMPLETE	
11	600.895	1	SET OF GASKET	
10	610.028	1	GASKET POLYPAC DBM 157118	
9	610.029	1	O-RING 219 (ø15.08 x 2.62)	
8	610.026	1	O-RING OR 139 (ø32.09 x 3.53)	
7	610.027	1	GASKET POLYPAC B 110078 (ROD ø20)	
6	610.025	1	GASKET WRM 078110 (ROD ø20)	
5	610.646	1	NUT	
4	220.668	1	PISTON	
3	210.288	1	CYLINDER HEAD	
2	100.742	1	CYLINDER BARREL	
1	100.741	1	ROD	
ITEM	PART NO.	Q. ty	DESCRIZIONE	NOTE

TABLE NO. 100.214

DM/6-7 CYLINDER PART. NO 100.214

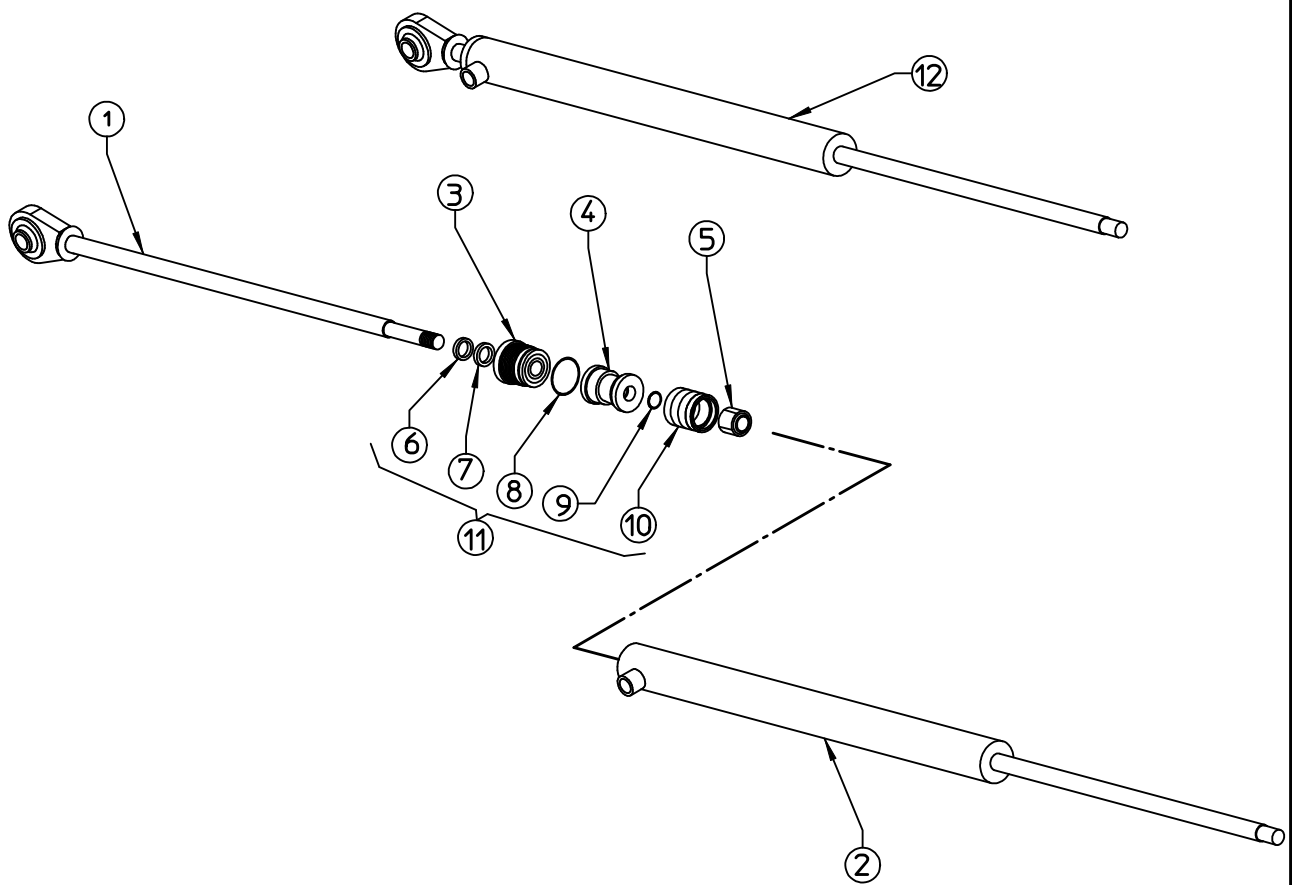

12	100.214	1	CYLINDER DIA.50 mm COMPLETE	
11	610.397	1	SET OF GASKET	
10	600.648	1	GASKET	
9	600.646	1	GASKET	
8	610.090	1	GASKET	
7	610.436	1	GASKET	
6	610.435	1	GASKET	
5	600.642	1	NUT	
4	200.304	1	PISTON	
3	210.671	1	CYLINDER HEAD	
2	100.347	1	CYLINDER BARREL	
1	100.346	1	ROD	
ITEM	PART NO.	Q. ty	DESCRIZIONE	NOTE

CARDAN SHAFT PART NO. 630.430 DM 4-5

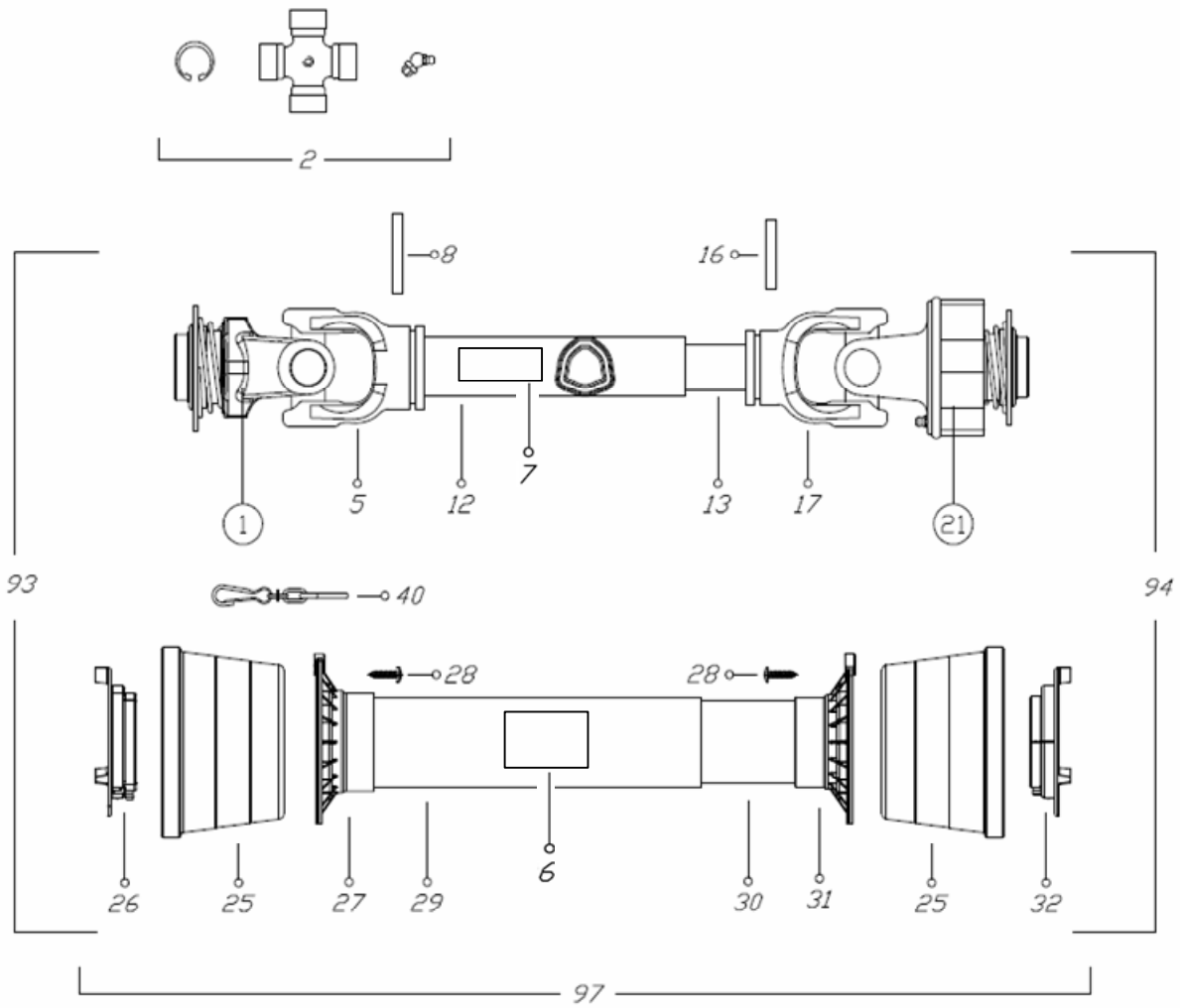

①

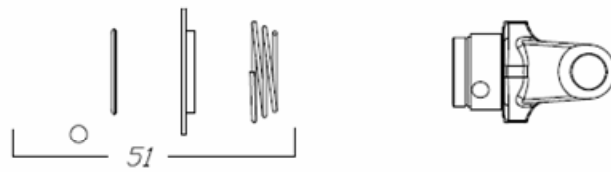

②①

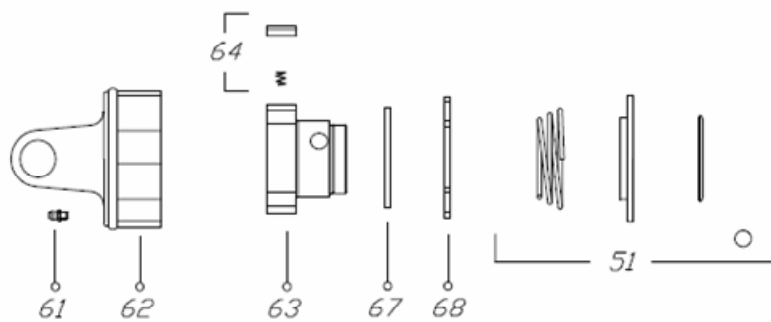

CARDAN SHAFT PART NO. 630.430 DM 4-5			
POS.	DESCRIPTION	Q.ty	PART NO
01	YOKE	1	620.825
02	CROSS JOURNAL ASS.	2	610.235
05	OUTER TUBE YOKE	1	610.236
06	LABEL "DANGER ROTATING"	1	001.411
07	LABEL "DANGER SHIELD..."	1	001.316
08	FLEXIBLE PIN	1	610.208
12	CM. 100 CARDAN TUBE(*)	1	610.209
13	CM. 100 CARDAN TUBE(*)	1	610.237
16	FLEXIBLE PIN	1	610.211
17	INNER TUBE YOKE	1	610.238
21	FREE WHEEL	1	620.898
25	CONE SHIELD BELL 03-04	2	630.400
26	OUTER BEARING 03-04	1	630.401
27	OUTER BASE CONE 03-04	1	630.402
28	SCREW	6	630.389
29	OUTER SAFETY TUBE	1	630.403
30	INNER SAFETY TUBE	1	630.404
31	INNER BASE CONE 03-04	1	630.405
32	INNER BEARING 03-04	1	630.406
40	CHAIN	1	610.068
51	BALL COLLAR KITT	2	620.830
61	GRAESE NIPPLE	1	610.206
62	OUTER CASING WITH YOKE	1	610.354
63	HUIB 1 3/8"z6	1	630.396
64	RATCET TOOTH	3	620.873
67	RETAINING RING	1	620.874
68	CIRCLIP	1	610.253
93	OUTER HALF SHAFT	1	630.408
94	INNER HALF SHAFT	1	630.409
97	SAFETY GUARD	1	630.410

CARDAN SHAFT PART NO. 630.431 DM 6-7

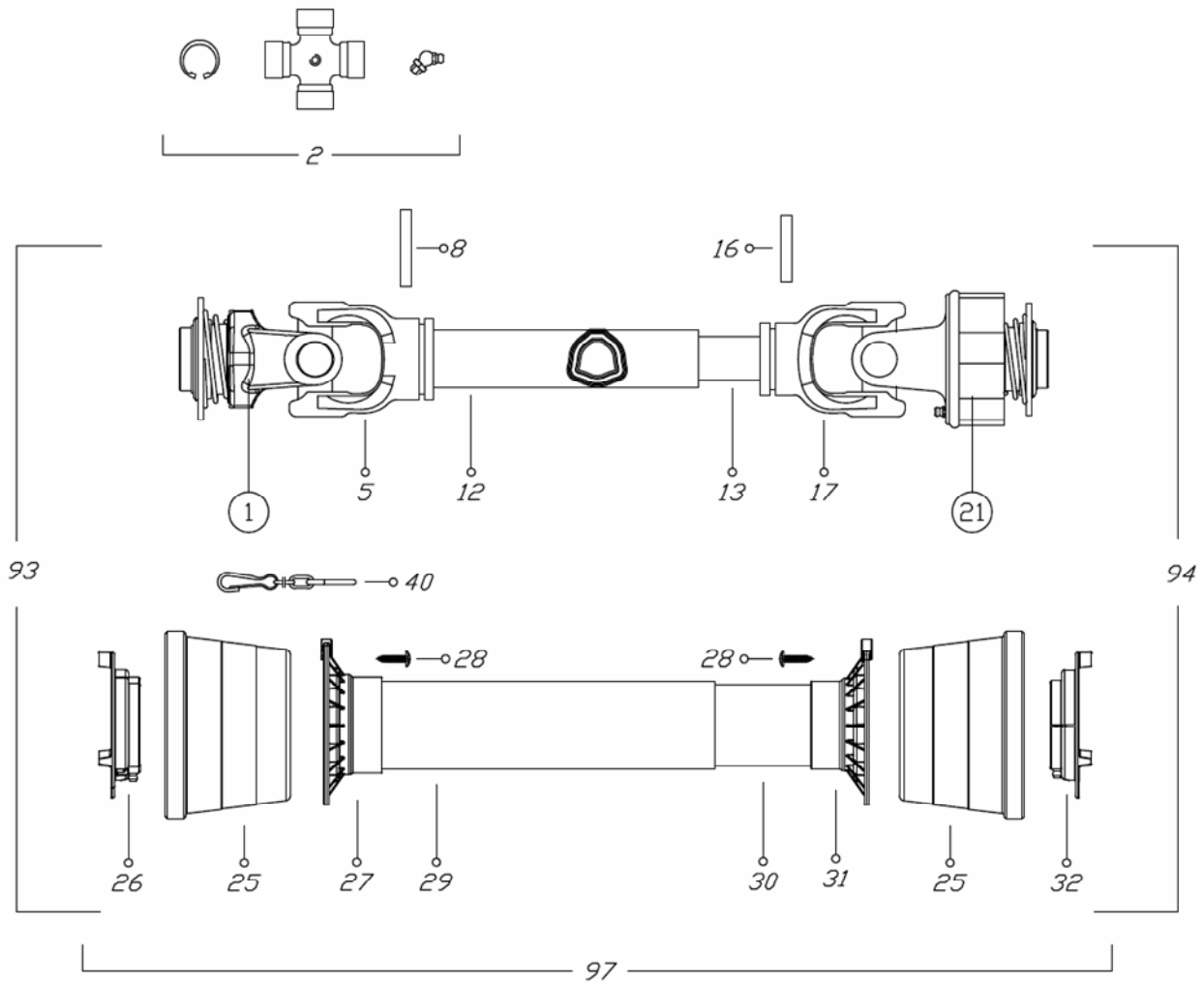

①

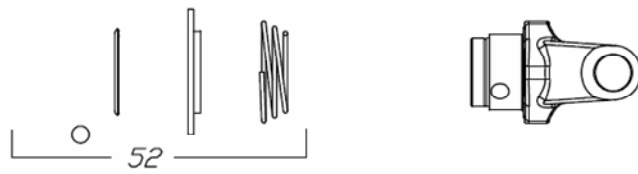

②

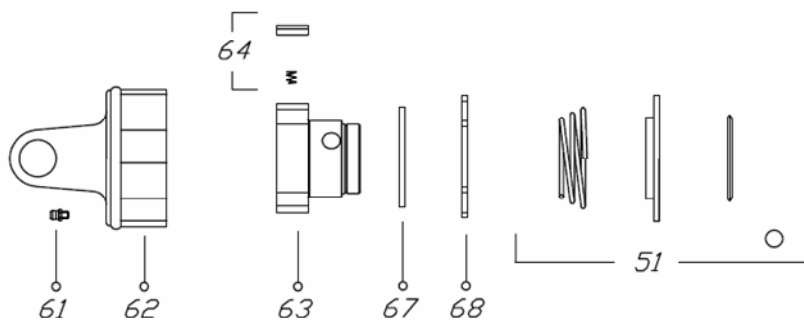

CARDAN SHAFT PART NO 630.431 DM 6-7			
POS.	DESCRIPTION	Q.ty	PART NO
01	YOKE	1	630.382
02	CROSS JOURNAL ASS.	2	610.368
05	OUTER TUBE YOKE	1	610.370
06	LABEL "DANGER ROTATING"	1	001.411
07	LABEL "DANGER SHIELD..."	1	001.316
08	FLEXIBLE PIN	1	630.383
12	CM. 100 CARDAN TUBE(*)	1	610.372
13	CM. 100 CARDAN TUBE(*)	1	610.373
16	FLEXIBLE PIN	1	630.384
17	INNER TUBE YOKE	1	610.375
21	FREE WHEEL	1	630.385
25	CONE SHIELD BELL 05-06	2	630.386
26	OUTER BEARING 05	1	630.387
27	OUTER BASE CONE 05-06	1	630.388
28	SCREW	6	630.389
29	OUTER SAFETY TUBE	1	630.390
30	INNER SAFETY TUBE	1	630.391
31	INNER BASE CONE 05-06	1	630.392
32	INNER BEARING 05	1	630.393
40	CHAIN	1	610.068
51	BALL COLLAR KITT	1	620.830
52	BALL COLLAR KITT	1	630.394
61	GRAESE NIPPLE	1	610.206
62	OUTER CASING WITH YOKE	1	630.395
63	HUIB 1 3/8"z6	1	630.396
64	RATCET TOOTH	3	620.873
67	RETAINING RING	1	620.874
68	CIRCLIP	1	610.253
93	OUTER HALF SHAFT	1	630.397
94	INNER HALF SHAFT	1	630.398
97	SAFETY GUARD	1	630.399

2. General information

2.1 Warranty

The manufacturer warrants new machinery to be free from defects in material and workmanship at the time of delivery to the original purchaser if correctly set up and operated according to this Operator's Handbook.

The manufacturer undertakes to repair or replace free of charge any defective part which should be returned by the purchaser (freight prepaid) and found to be defective on inspection authorised by the manufacturer during the warranty period.

This warranty shall be valid for 12 (twelve) months from the delivery of the goods to the original purchaser.

If the customer is unable to return the defective part to the manufacturer, the manufacturer cannot be held responsible for any cost due for repair or replacement of any part of the machine. He shall only supply the part(s) required for such repair and/or replacement.

The warranty shall be considered null and void when it is evident that the machine has been improperly used or at least repaired without authorisation.

The manufacturer shall not be held responsible for any obligation or agreement reached by any manufacturer employers, agents or dealers who do not comply with the above warranty. The manufacturer cannot be held responsible for the subsequent damages. This warranty replaces any other warranty, either explicit or implied, as well as any other obligation of the manufacturer.

NOTE:

ALL WARRANTY WORK OR REPAIRS MUST BE APPROVED BY THE MANUFACTURER BEFORE WORK BEGIN.

ANY WORK OR REPAIRS MADE BEFORE APPROVAL MAY NOT BE COVERED UNDER WARRANTY.

PLEASE NOTIFY YOUR SALES & SERVICE DEPARTMENT OF THIS POLICY.

2.2 Machine identification data

The machine is identified by means of the following technical data:

- Type of machine
- Registration number
- Year of manufacture
- Weight

stamped on the rating plate fastened to the frame of the machine. This data should be mentioned when requesting any replacements or information.



GUIDE TO THE SIGNS AND SYMBOLS USED IN THIS MANUAL AND THEIR LOCATION ON THE MACHINE

2.3 SIGNS AND SYMBOLS

These signs and symbols give information to the operator on how to make the best use of the machine so as to prolong life, avoid damage, optimize work and, above all, to avoid injury to the operator and anyone within range of the machine.

2.4 WARNING SIGNS



1. Before beginning operations, read the instruction manual carefully.



2. Indicates that it is dangerous to touch the Cardan shaft. For all other information regarding the Cardan shaft, see the use-and-maintenance booklet specifically for the Cardan shaft which, together with this manual, makes up the documentation on safety, use and maintenance of the machine.



3. Risk of possible ejection of blunt objects. Keep a safe distance from the machine.

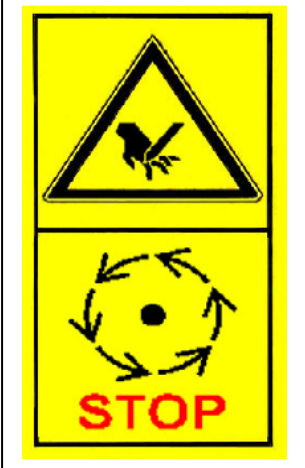

4. This indicates the risk of cutting one's hand. Keep at a safe distance.



5. This indicates the risk of cutting one's foot. Keep at a safe distance.



6. Indicates danger caused by accidental fall of suspended arms. Keep safe distance



7. Risk. Rotation part



8. Risk. Noise



9. Shows the direction of rotation of the power takeoff and the maximum number of revolutions.

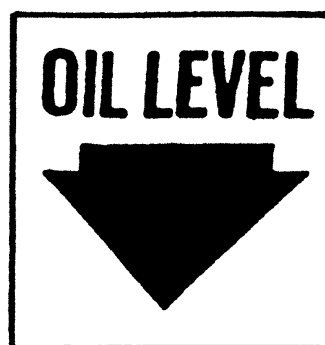

10. This indicates the oil level.

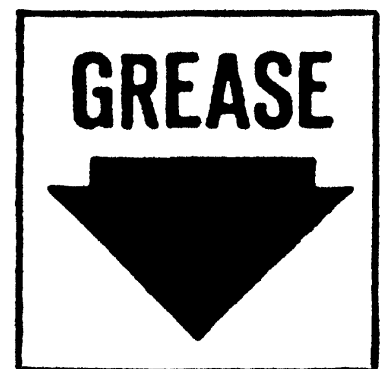

11. Indicates a greasing point

3. GENERAL SUMMARY OF SAFETY AND ACCIDENT - PREVENTION INSTRUCTIONS

3.1 GENERAL SUMMARY OF SAFETY AND ACCIDENT-PREVENTION INSTRUCTIONS

Read all the directions carefully before using the machine. When in doubt, seek advice from the manufacturers.

The manufacturing company declines all responsibility for non-compliance with the following safety and accident-prevention instructions.

- 1-** Pay attention to the danger signs and symbols in this manual and on the machine.
- 2-** Do not touch moving parts.
- 3-** All work on the machine (including adjustments) must always be carried out with the tractor immobilized and the engine switched off.
- 4-** On no account may persons or animals be carried on the machine.
- 5-** Driving the tractor with the machine connected is absolutely forbidden to persons lacking suitable experience, or who are in poor health, or who do not have a suitable driving license.
- 6-** All accident-prevention measures recommended in this manual should be scrupulously observed.
- 7-** Connecting the machine to the tractor creates a different weight distribution on the axles and so it is essential to ensure that the tractor-machine combination is stable in all anticipated working conditions. It is therefore necessary to have exact instructions from the tractor manufacturers. If such instructions are not available, suitable tests should be conducted in safe conditions in order to assess stability.
- 8-** Once the machine is connected, it can only be controlled through a Cardan shaft complete with the required overload protection and guard secured with the appropriate small chains. Be aware of the rotational direction of the Cardan shaft.
- 9-** Before operating the tractor and machine, check that all transport and operational safety devices are complete and working.
- 10-** When driving on public roads, you should comply with the Highway Code regulations for the country concerned.
- 11-** Do not exceed the tractor axle maximum weight and the total mobile weight. Heed transport regulations.
- 12-** Before starting work, familiarize yourself with the control devices and how they work.
- 13-** Wear suitable clothes. Do not wear clothing which is loose or which could become entangled in rotating or moving parts.

-
- 14-Connect the machine to a suitably powerful tractor by using an appropriate lifting unit and in accordance with instructions.
 - 15-Take maximum care when connecting and disconnecting the machine to and from the tractor.
 - 16-The machine and any road transport attachments must bear the appropriate signs and symbols and have suitable protection.
 - 17-Never leave the driving seat when the tractor is running.
 - 18-It is extremely important to appreciate that road holding, steering and braking may be significantly affected with the machine attached.
 - 19-When turning corners with the machine attached, be aware of the fact that the centrifugal force will alter due to the change in the center of gravity.
 - 20-Before engaging the power takeoff check the preset revolution speed. Do not change speed from 540 rpm to 1000 rpm.
 - 21-Under no circumstances should anybody stand near the machine or any moving parts. It is the duty of the operator to ensure that this requirement is respected.

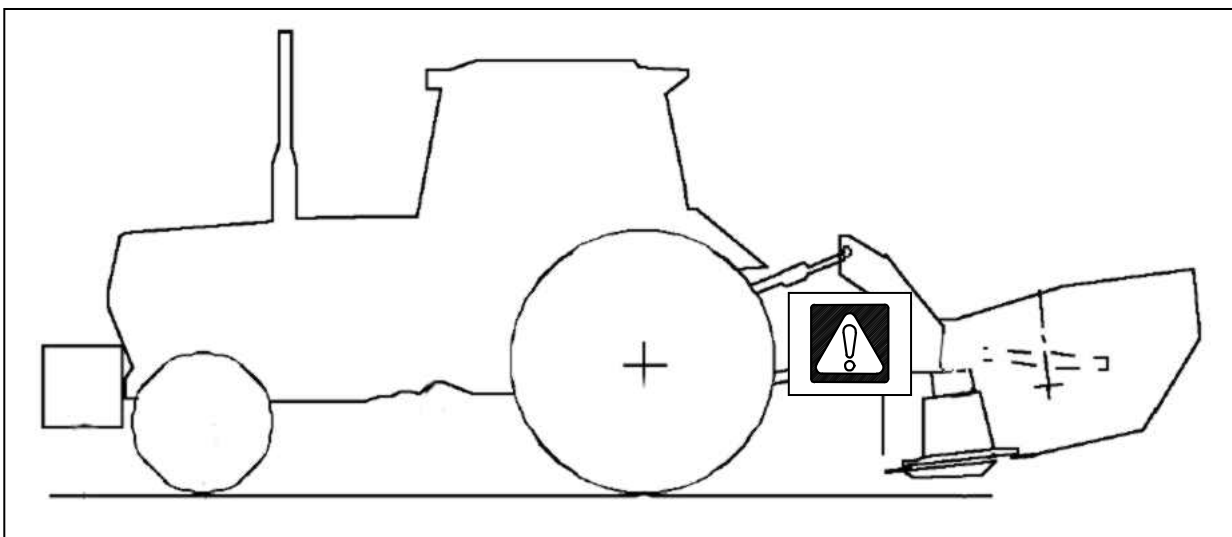

- 22-Under no circumstances should anybody go between the tractor and the machine when the engine is running and the Cardan shaft is engaged, especially without first having applied the parking brake and placed chocks against the wheels.
- 23-Before connecting or disconnecting the machine to or from the 3-point linkage, put the lifting unit lever into the locked position.
- 24-The connection pins on the machine must match the connection sockets on the lifting unit.
- 25-During transport, secure the lateral lifting arms with the appropriate chains and tighteners.
- 26-When the machine is raised during road transport, put the tractor's hydraulic lifter lever into the locked position.
- 27-Only use the Cardan shaft provided by the manufacturer and, in case of replacement, substitute it with one having the same characteristics.
- 28-Regularly check all protection on the Cardan shaft. This should always be in excellent condition and securely fixed.

- 29-**It is important to ensure that the protection on the Cardan shaft is complete.
- 30-**Connection and disconnection of the Cardan shaft must be carried out with the engine switched off.
- 31-**Pay particular attention to the correct connection and safety of the Cardan shaft and the power takeoffs on the machine and the tractor.
- 32-**Prevent the cardan shaft protection from rotating using the chains supplied.
- 33-**Before engaging the power takeoff, make sure that there are no people or animals in the vicinity and that the selected engine speed corresponds to that permitted. Never go above the maximum permitted.
- 34-**Do not engage the power takeoff when the engine is not running.
- 35-**Always disengage the power takeoff when the Cardan shaft is at too wide an angle (it should never be more than 35° Fig. 3.1) and when it is not in use.
- 36-**Only clean and grease the Cardan shaft when the power takeoff is disengaged, the engine is off, the parking brake is applied and the ignition key is removed.
- 37-**On disconnecting the Cardan shaft, replace the protective hood on the power takeoff shaft.
- 38-**Prolonged use of the machine can cause the drive boxes to become hot. To avoid any risk of getting burnt, avoid touching these areas both during use and some time afterwards.
- 39-**Periodically check screws and nuts for tightness and grip. Tighten if necessary.
- 40-**When carrying out maintenance work or replacing the blades, raise the machine and rest on adequate supports.
- 41-**Use the quantities of grease and oil advised.
- 42-**Spare parts must meet the requirements as defined by the manufacturer. Use only original spare parts.
- 43-**Safety decals must always be clearly visible. They must be kept clean and replaced if they become too illegible (they can be ordered from the agent if necessary).
- 44-**The instruction booklet must be available for the lifetime of the machine.
- 45-**and rest on adequate supports.
- 46-**Use the quantities of grease and oil advised.
- 47-**Spare parts must meet the requirements as defined by the manufacturer. Use only original spare parts.
- 48-**Safety decals must always be clearly visible. They must be kept clean and replaced if they become too illegible (they can be ordered from the agent if necessary).
- 49-**The instruction booklet must be available for the lifetime of the machine.

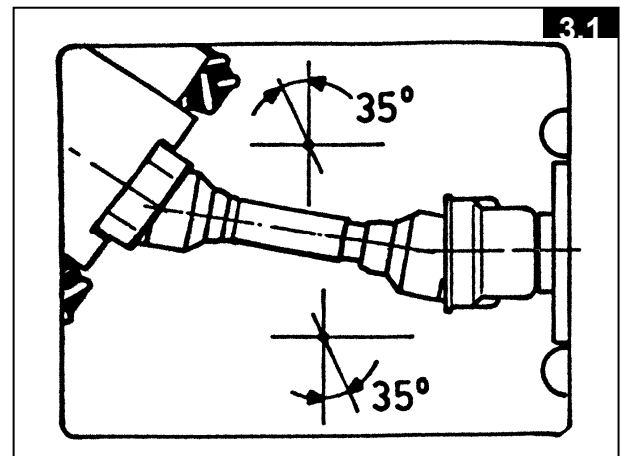

4. Technical characteristics

4.1 Tractor requirements

Power takeoff speed (PTO)	revs/min	540
Max hydraulic pressure	bar	160
Minimum power required	(see 4.2)	
Simple distributor	n°	1

4.2 Description of the machine

Type of machine		DM/4	DM/5	DM/6	DM/7
Number of disks	n°	4	5	6	7
Number of knives per disk	n°	2	2	2	2
Working width	m (inch)	1.65 (65)	2.09 (82)	2.45 (96)	2.85 (112)
Gear ratio		2.73			
Peripheral knife speed (PTO 540 revs/min)	m/s (ft/s)	81 (266)			
Minimum power required	kW (HP)	26 (35)	30 (40)	34 (46)	39 (52)
Weight	kg (Lb)	372 (820)	411 (906)	489(1078)	543(1197)

4.3 Technical notes

We will provide a few examples to make it easier to choose which of the various accessories to use for each step of assembly. An approximate equivalent of the metric measurements is given in inches.

Example: a pin with a 25 mm (1") diameter and a screw with an M 16 (5/8") diameter, both 50 mm (2") long, will be listed as:

D 25 x 50 (D 1" x 2") and M 16 x 50 (D 5/8" x 2").

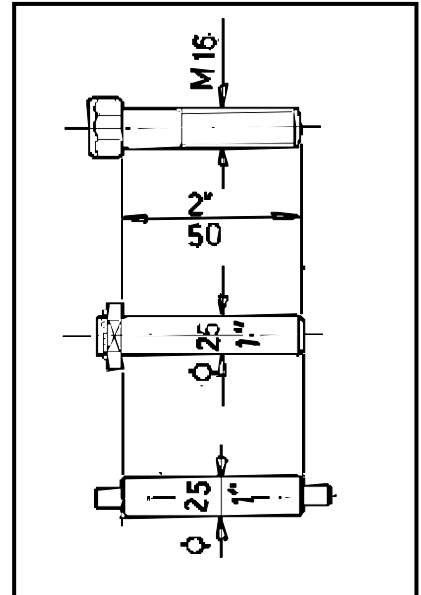

2) SHIMS, SPACERS, BUSHINGS AND WASHERS

Example: a shim, spacer, bushing or washer with an inside diameter of 25 mm (1"), outside diameter of 50 mm (2") and thickness or length of 13 mm (1/2") will be listed as:

D 25 - 50 x 13 (D 1" - 2" x 1/2").

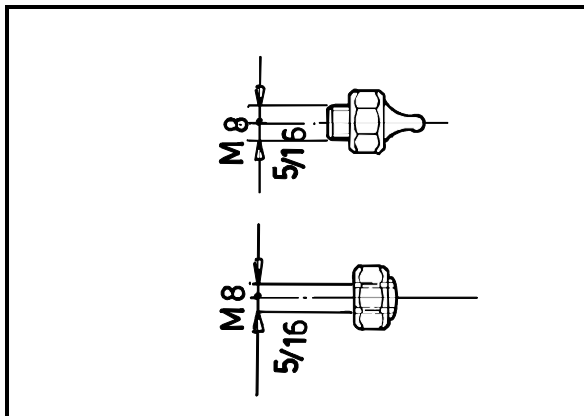
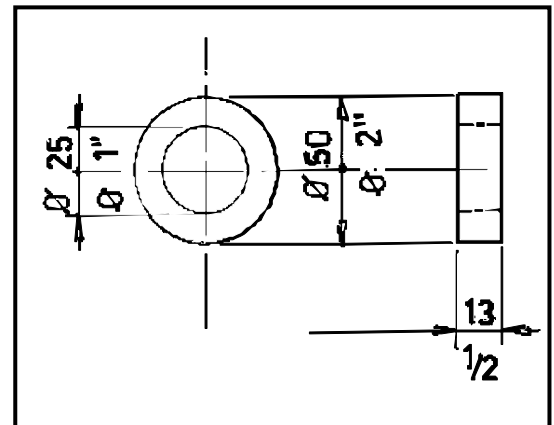

3) NUTS, GREASE NIPPLES

Example: a nut or grease nipple having a thread of M 8 (5/6") will be listed as:
M 8 (5/16")

4) CONVERSION CHART METRIC/USA

mm	inches	mm	inches	mm	inches	mm	inches
1	1/32	26	1" 1/64	55	2" 5/32	300	11" 51/64
2	5/64	27	1" 1/16	60	2" 23/64	350	13" 49/64
3	7/64	28	1" 3/32	65	2" 35/64	400	15" 47/64
4	5/32	29	1" 9/64	70	2" 3/4	450	17" 45/64
5	3/16	30	1" 11/64	75	2" 15/16	500	19" 43/64
6	15/64	31	1" 7/32	80	3" 9/64	550	21" 41/64
7	17/64	32	1" 1/4	85	3" 11/32	600	23" 39/64
8	5/16	33	1" 19/64	90	3" 17/32	650	25" 37/64
9	11/32	34	1" 21/64	95	3" 47/64	700	27" 35/64
10	25/64	35	1" 3/8	100	3" 59/64	750	29" 33/64
11	27/64	36	1" 13/32	110	4" 21/64	800	31" 31/64
12	15/32	37	1" 29/64	120	4" 23/32	850	33" 29/64
13	1/2	38	1" 31/64	130	5" 7/64	900	35" 27/64
14	35/64	39	1" 17/32	140	5" 1/2	950	37" 25/64
15	37/64	40	1" 9/16	150	5" 57/64	1000	39" 23/64
16	5/8	41	1" 39/64	160	6" 19/64	1050	41" 21/64
17	21/32	42	1" 41/64	170	6" 11/16	1100	43" 19/64
18	45/64	43	1" 11/16	180	7" 5/64	1150	45" 17/64
19	47/64	44	1" 23/32	190	7" 15/32	1200	47" 15/64
20	25/32	45	1" 49/64	200	7" 55/64	1250	49" 13/64
21	13/16	46	1" 51/64	210	8" 17/64	1300	51" 11/64
22	55/64	47	1" 27/32	220	8" 21/32	1350	53" 9/64
23	57/64	48	1" 7/8	230	9" 3/64	1400	55" 7/64
24	15/16	49	1" 59/64	240	9" 7/16	1450	57" 5/64
25	31/32	50	1" 61/64	250	9" 53/64	1500	59" 3/64

5. Assembly

5.1 Instructions on how to assemble models DM 4-5

Refer to fig. 1 and carry out the following steps in the order indicated:

- 1) Use special nut 32 and special washer 31 already in the spindle to mount disc-conveyor 30 (dynamometric spanner set at 32kgm \320Nm torque) in the cutterbar (see picture detail). Be attention to discs layout, see fig.15.
- 2) Use pin 3 - D 30 x 178 (D 1³/₁₆ x 7") to insert support 1 into the special slot on frame 2 and fasten with washer 4 (DIN 125A) and nut 5 - M 20 (D 3/4").
- 3) Use the four screws 13 M 12 x 30 (D 1/2" x 1¹¹/₆₄) and helical spring lock washers 16 (similar to DIN 127B) to mount support 11 on gear box 12.
- 4) Use pin 6 D 30 x 106 (D 1³/₁₆ x 4") to insert distance washer 7 D 30 – 42 x 5 (D 1³/₁₆ – 1⁵/₈ x 3/16"), tie rod 8, distance washer 9 D 30 – 42 x 10 (D 1³/₁₆ – 1⁵/₈ x 3/8") and hydraulic cylinder 10 into the special slot on support 1 and fasten into position with peg 15 D 8 x 50 (D 5/16" x 2").
- 5) Use pin 14 D 25 – 19 x 45 – 67 (D 1" – 3/4" x 2" – 2³/₄) to insert hydraulic cylinder 10 into support 11. Do not fasten at this stage.

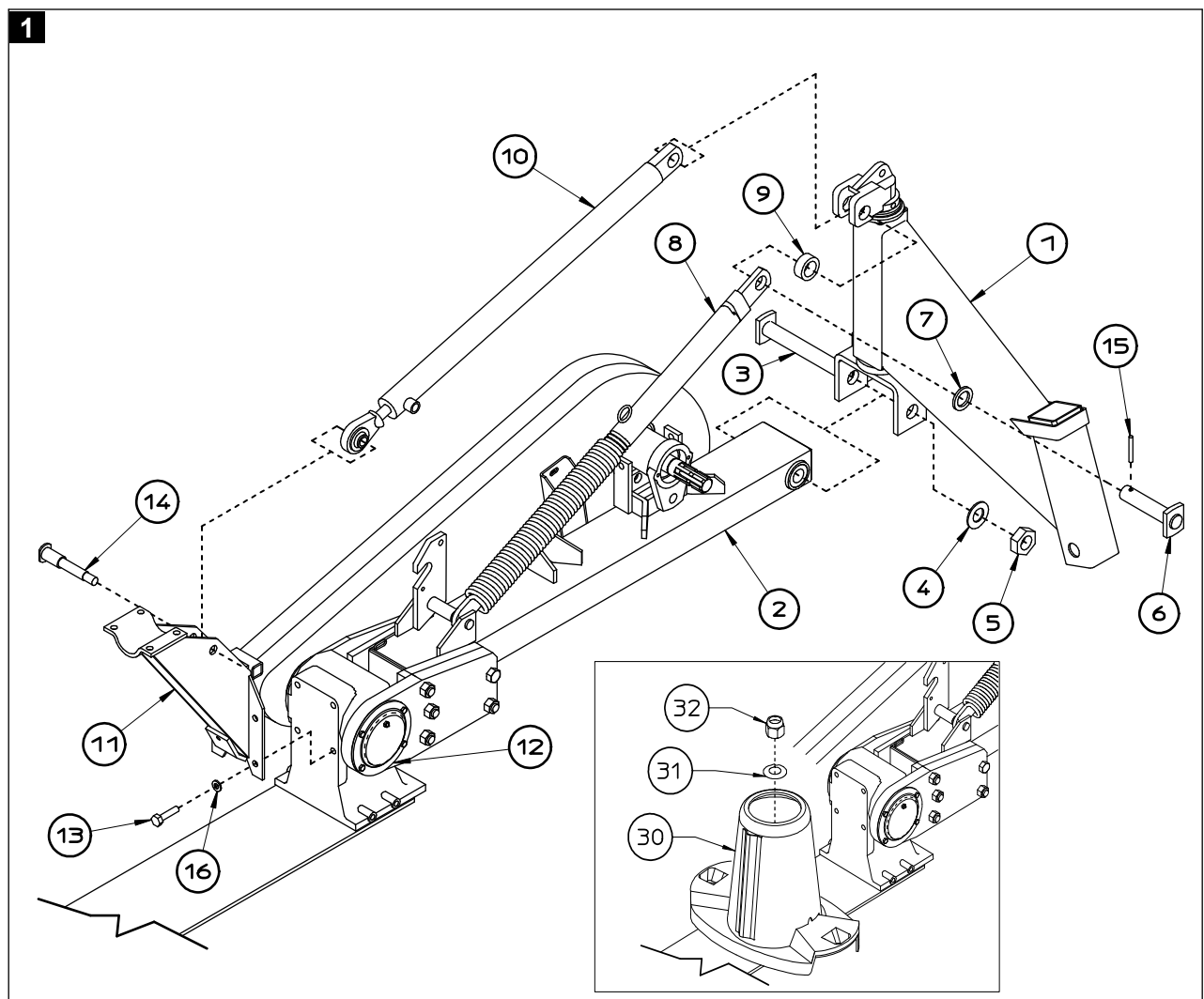

Refer to fig. 2 and carry out the following steps in the order indicated:

- 1) Insert rest foot 13 into the slot on support 1 and fasten into position with pegs 14 and 15 D 8 x 50 (D 5/16" x 2").
- 2) Use pin 2 D 28 – 30 – 22 x 260 (D 1"1/8 - 1"3/16 – 7/8" x 10"1/4) to insert arc 9 into the slot on support 1 and fasten into position with washer 3 and nut 4.
- 3) Insert rest foot 10 into the slot on arc 9 and fasten into position with pegs 11 D 8 x 50 (D 5/16" x 2") and 12 and 12.
- 4) Insert pin 6 D 22 – 30 – 22 x 260 (D 7/8" - 1"3/16 – 7/8" x 10"1/4) into the slot on arc 9 and fasten into position with washer 7 (similar to DIN 127B) and ring nut 8.
- 5) Insert bushing 5 D 22 – 28 x 45 (D 7/8" – 1"1/8 x 1"3/4) into pin 6 for coupling (2nd class) to the tractor.

2

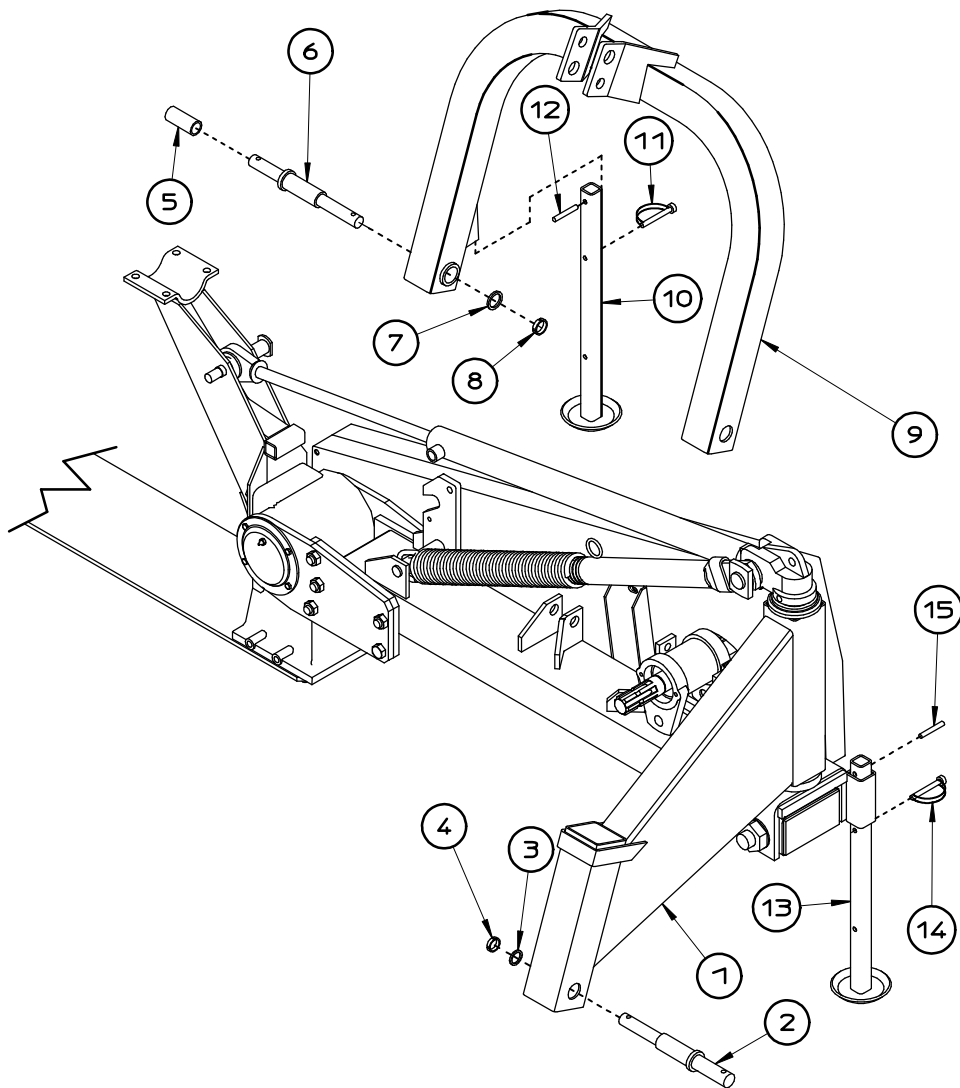

Refer to fig. 3 and carry out the following steps in the order indicated:

- 1) Mount safety bar 1, hoist chain 11 with two clevis 17 and washer 18 ($\varnothing 23 \times \varnothing 39 \times 3.5$) in pin 2 and fasten with peg 13.
- 2) Use pin 3 D 20 x 67 (D 3/4" x 2 5/8") to assemble safety bar 1 into slot 5 and fasten into position with E-clip 4.

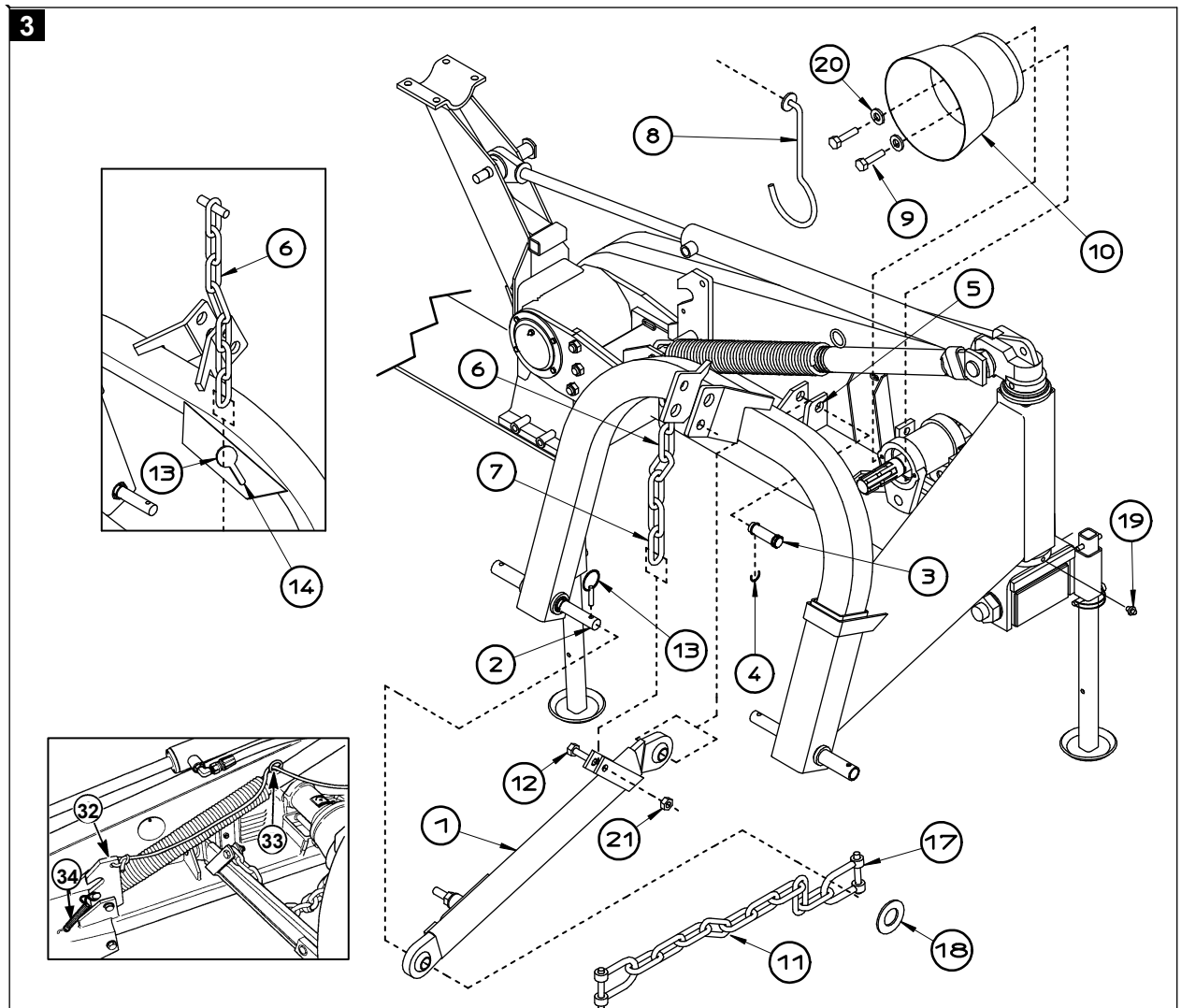

- 3) Insert chain 6 (for adjustment see 7.3) into hole 13 on the arc and fasten one ring on the chain into slot 14.
- 4) Use screw 12 M 12 x 55 (D 1/2" x 2" 10/64) and nut 21 to fasten ring 7 on chain 6 to safety bar 1.
- 5) Use screws 9 M 8 x 12 (D 5/16" x 1/2") and flat washer 20 ($\varnothing 8.5 / \varnothing 24$) to assemble casing 10.
- 6) Insert cardan support 8 into one of the holes not used by the pin on the third point.
- 7) Mount grease nipple 19.
- 8) Tie the rope to the safety latch 32 and then thread it through the steel circle 33 (see figure detail).
- 9) Remember to link the spring 34 to transport hook 32 (see figure detail).

ONLY DM/4

Refer to fig. 4 and carry out the following steps in the order indicated:

- 1) Raise the bar off the ground and rest it on a support that is sufficiently stable in order to be able to easily insert slide 1 into slots 2 on the gear box.
- 2) Select one of the series of horizontal holes on slide 1 according to the cutting height required.
- 3) Use screws 5 M 10 x 35 (D 3/8" x 1"1/2), washers 4 (DIN 125A) and distance 3 to fasten slide 1 on the side opposite forward movement and use screws 16 M10 x 20 (D 3/8" x 50/64") and washers 15 (DIN 125A) to fasten it on the opposite side.

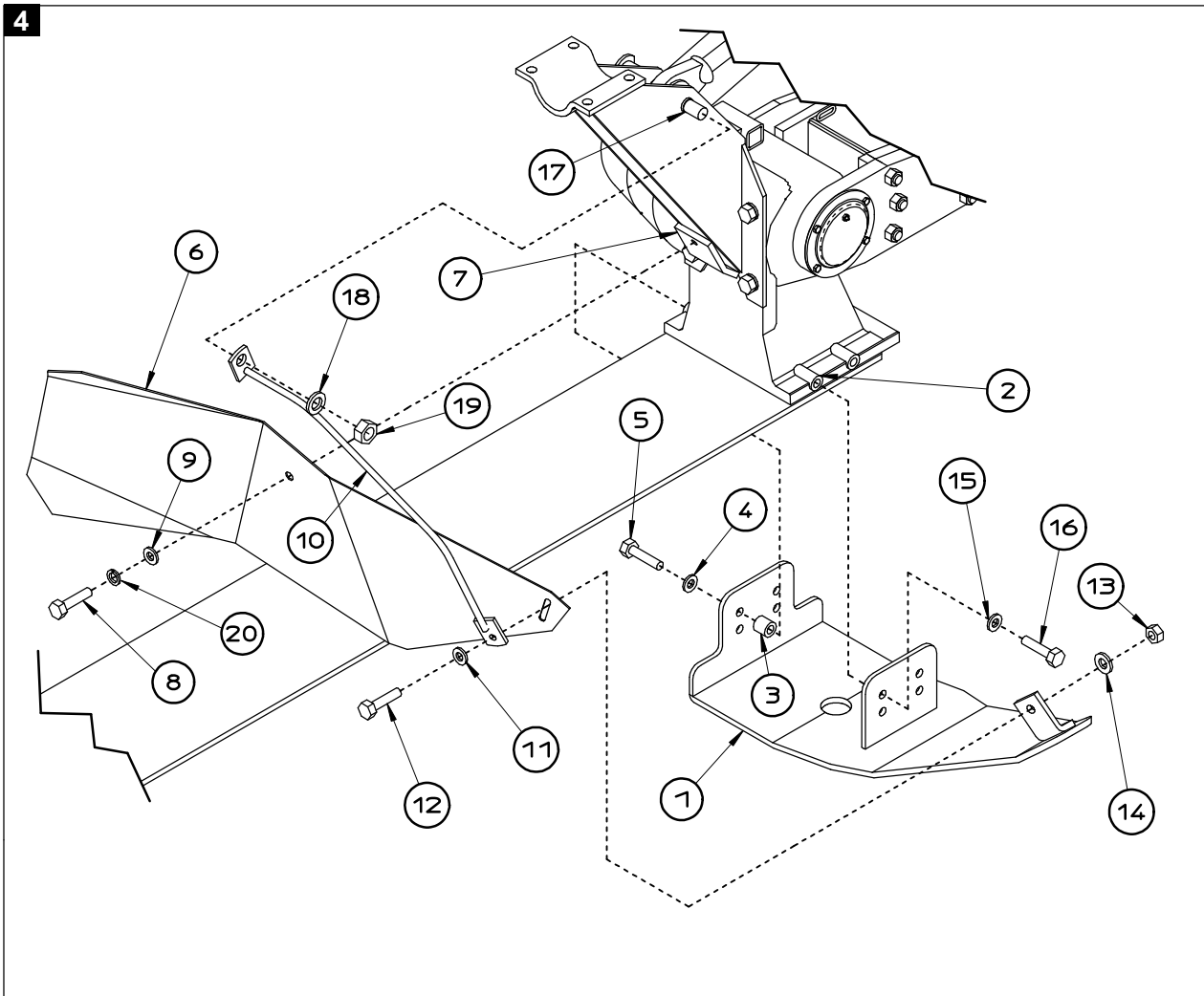

DM/5 DM/6 DM/7

Refer to fig. 4 and carry out the following steps in the order indicated:

- 1) Mount conveyor sheet 6 over the holes on support 7 and slide 1 and use screw 8 M 10 x 30 (D 3/8" x 1"11/64) lock washer 20 (similar to DIN 127B) and washer 9 (DIN 125A) to fasten into position without tightening at this stage.
- 2) Insert protection 10 into pin 17 together with screw 12 M 8 x 30 (D 5/16" x 1"3/16) and flat washer 11 (DIN 125A) and 14 (ø9/24x2) into the hole on slide 1 and slot on conveyor sheet 6.
- 3) Use flat washer 18 (DIN 125A) and nut 19 (M16) to fasten pin 17 and at the same time use washer 14 (ø9/24x2) and nut 13 and screw 8 to fasten screw 12 to support 7.

Refer to fig. 5 and carry out the following steps in the order indicated:

- 1) Mount the main tube 1 on the frame, move it on to flange 2 and 3 assembled with screws 4 M 12 x 55 (DIN 931), nuts 6 (M12) and flat washers 5 (DIN 125A), and at the same time insert the curved tube 16 into the relevant hinge 18; do not tighten the set of screws 3-4-5-6 for the time being; make sure that the positioning tooth on tube 1 is held in the horizontal connection plane of flanges 2 and 3.
- 2) Insert tubes 7 and 10 into support 21 (for models DM 6-7 only).
- 3) Insert the curved tubes 8 and 9 into the slots on tubes 10 and 7.
- 4) Mount the assembly set 7-8-9-10-21 on to the load bearing tube 1 connecting with welded screws 13 and use flat washers 11 and nuts 12 to tighten.
- 5) Insert tubes 14 and 15 into support 22 (for models DM 6-7 only).
- 6) Insert assembly set 14-15-22 into hinge 18 connecting with load bearing tube 1.
- 7) Use washer 19 (DIN 125A) and nut 20 (M10) to tighten hinge 22 into slot 18.
- 8) At the same time insert the curved tube 16 into the relevant hinge 18 and into tubes 14 and 15 and use flat washer 19 (DIN 125A) and nut 20 (M10) to tighten the hinge in the corresponding slot 18.
- 9) Carry out the same operation with curved tube 17, hinge 18, washer 19 (DIN 125A) and nut 20 (M10).
- 10) Use screws 24 M 8 x 25 (DIN 933), washer 25 (DIN 125A) nut 26 (M8) to mount support 23 in the curved tube 9.
- 11) Mount conveyor 37 in the support 27 of screw 34 M10x35 (DIN 933) washer 31 (DIN 125A) and nut 30 (M10) also use screw 38 M12X35 (DIN 933) and nut 39 (M12). Use the slot 35 to change the position of conveyor.
- 12) Mount screw 28 M 10 x 20 (DIN 933).
- 13) Secure the curtain 30 with front protection flipped towards the rear lacing ALL the straps 31 on the under side of the curtain (see figure detail).
- 14) **(OPTIONAL)** Mount conveyor 33 in the support 36 of screw 34 M10x35 (DIN 933) washer 31 (DIN 125A) and nut 30 (M10) also use nut 39 (M12). Use the slot 35 to change the position of conveyor

RIGHT WHEEL CONVEYOR KIT (OPTIONAL)

RIGHT WHEEL CONVEYOR KIT (OPTIONAL):

Remove conveyor sheet 6 shown in previous figure. Attach the conveyor support 1 to plate 2 with threaded holes welded to the body of the machine with screws 3 M 10 x 25 (D 3/8" x 1") and washers 8. Mount conveyor 5 in the slot 7 of screw 6 M 10 X 35 (d 3/8" X 1"3/8) on support 1 and tighten everything up with nut 9 and washer 8. Use the slot 7 to change the position of conveyor.



Make sure that when assembly operations have been finished, all nuts and bolts are correctly screwed up.

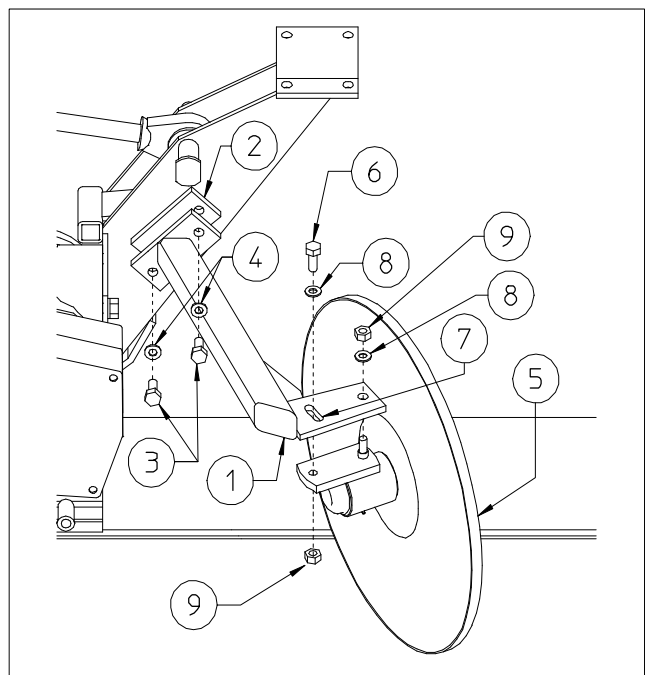

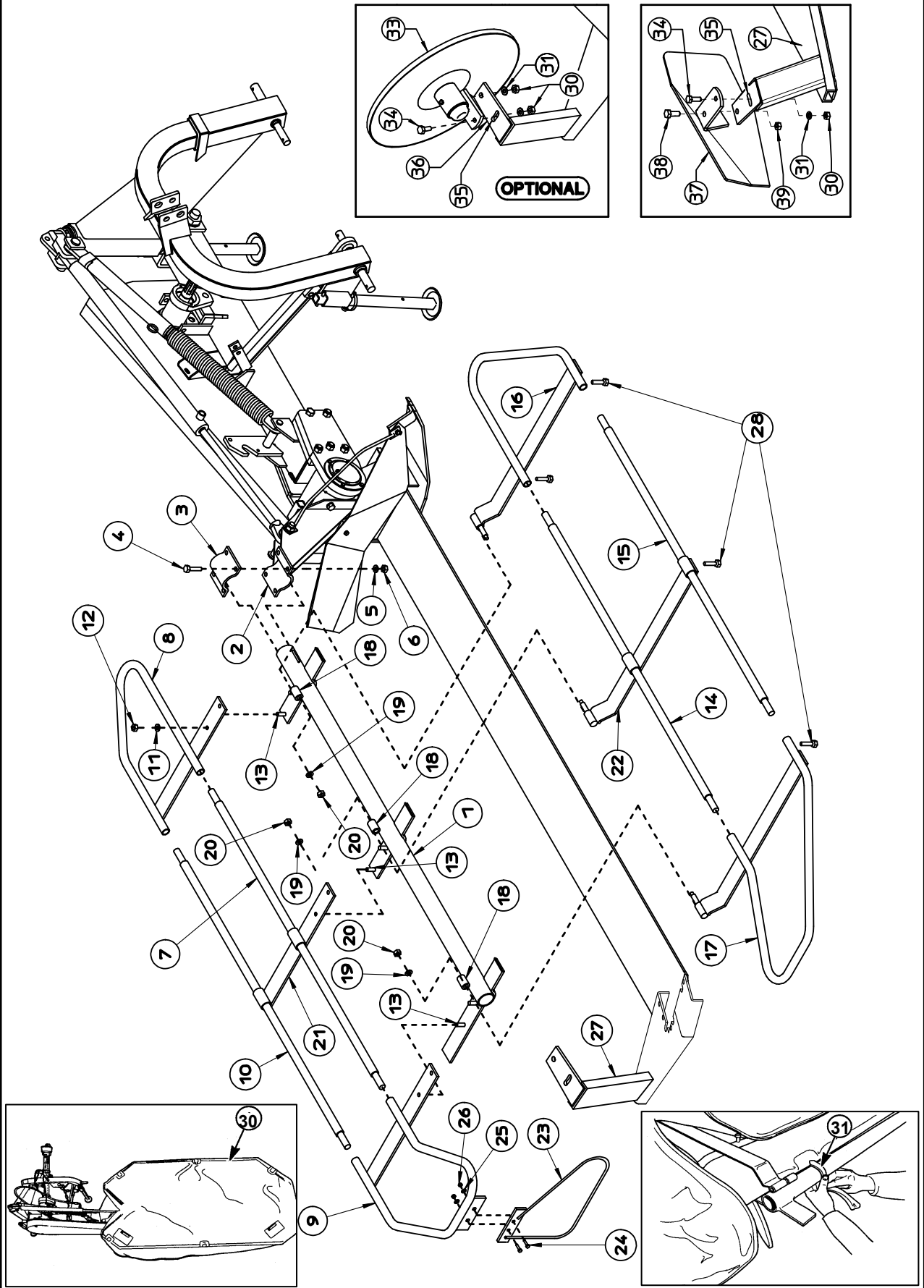

5.2 Instructions on how to assemble models DM 6-7

Refer to fig. 6 and carry out the following steps in the order indicated:

- 1) Use special nut 32 and special washer 31 already in the spindle to mount disc-conveyor 30 (dynamometric spanner set at 32kgm \320Nm torque) in the cutterbar (see picture detail). Be attention to discs layout, see fig.15.
- 2) Use pin 3 \varnothing 30 x 249 (D 1"3/16 x 10") to insert body 1 into the slot on body 2 and use washer 4 (\varnothing 21x37x3) and nut 5 (M20) to fasten into position.
- 3) Use the four screws 12 M 12 x 30 (D 1/2" x 1"11/64) and lock washer 11 (similar to DIN 127B) to mount support 10 on gear box 13.
- 4) Mount hydraulic cylinder 6 into the relevant slot on body 1 together with suspension 7 and fasten everything into position with peg 8 (\varnothing 8x50).
- 5) Use pin 9 \varnothing 25 – 19 x 45 – 67 (D 1" – 3/4" x 2" – 2"3/4) to insert hydraulic cylinder 6 into the slot on support 10 without tightening at this stage.

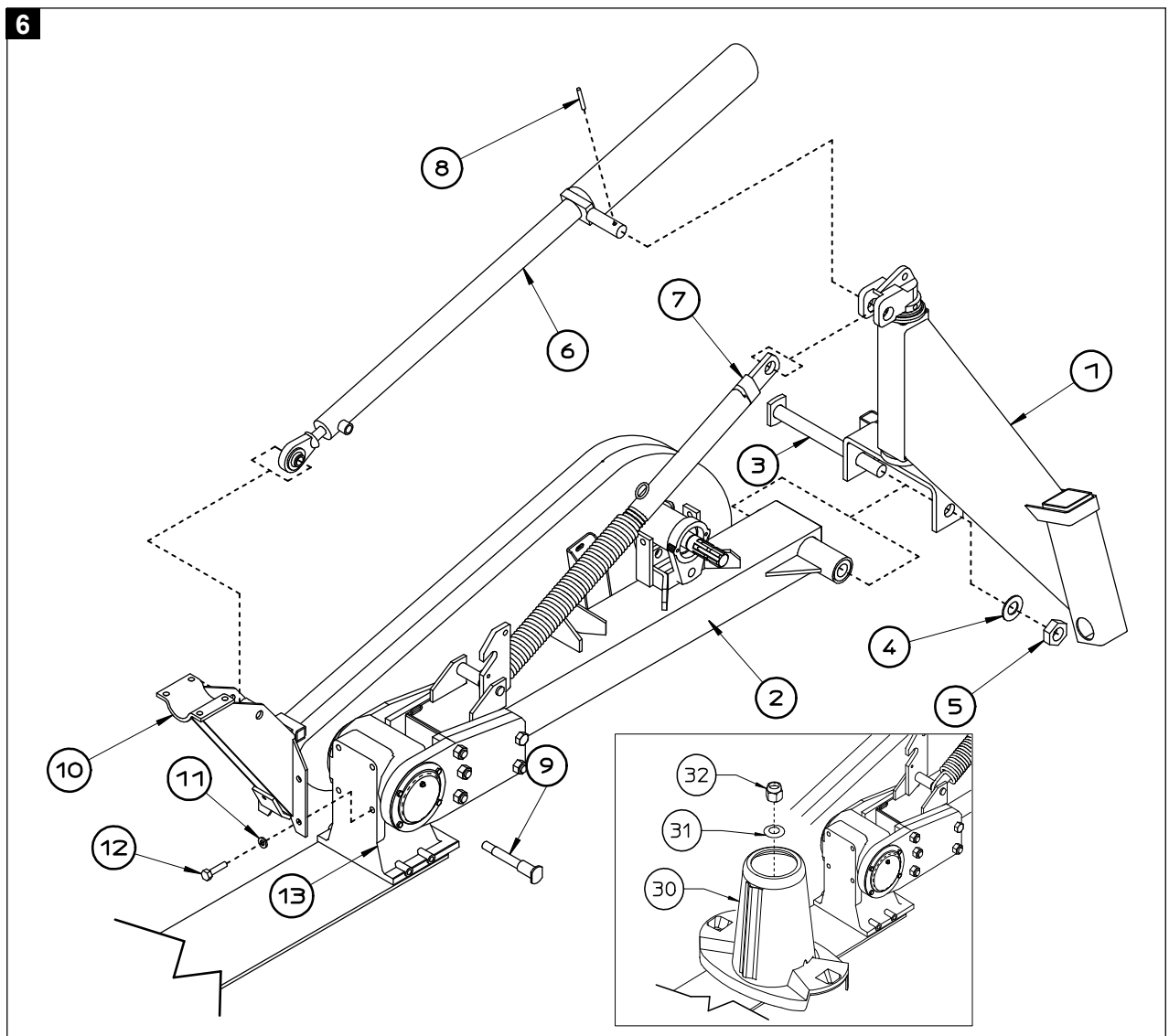

Refer to fig.7 and carry out the following steps in the order indicated:

- 1) Insert rest foot 13 into the slot on support 1 and fasten into position with pegs 14 \varnothing 8 x 50 (D 5/16" x 2") and 15.
- 2) Use bushing 2 to insert arc 8 into the slot on support 1 and fasten into position with washer 3 (\varnothing 55x70x5) and ring nut 4 (M55x2).
- 3) Insert pins 5 and 7 into their respective slots and use screws 6 and 9 M 8 x 80 (D 5/16" X 3"), and two washers 17 and two 19 and nuts 16 and 18 to fasten into the position which best suits the dimensions of the tractor.
- 4) Insert rest foot 10 into the slot on arc 8 and fasten into position with pegs 11 and 12 \varnothing 8 x 50 (D 5/16" x 2").
- 5) Insert pin 22 on 3rd point hitch 8 and lock it with lock washer 21(similar to DIN 127B) and nut 20 (M24x2).

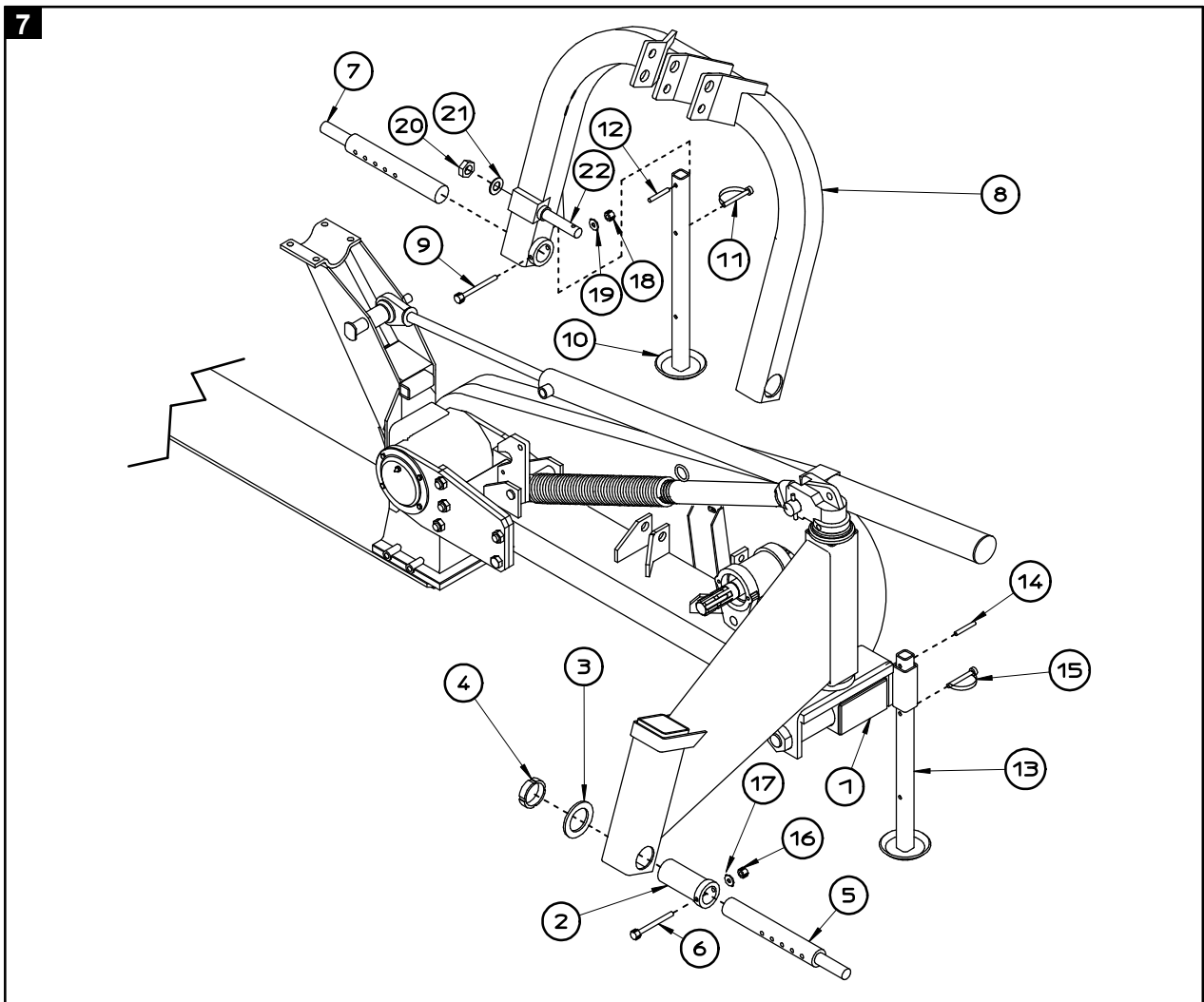

Refer to fig.8 and carry out the following steps in the order indicated:

- 1) Mount safety bar 1, hoist chain 11 with two clevis 17 and washer 18 $\varnothing 23 \times \varnothing 50 \times 4$ in pin 2 and fasten with peg 15.
- 2) Use pin 3 D 20 x 67 (D 3/4" x 2" 5/8) to insert safety bar 1 into slot 5 and fasten with E-clip 4.
- 3) Insert chain 6 (for adjustment see 5.3) into hole 13 on the arc and fasten one ring of the chain into slot 14.

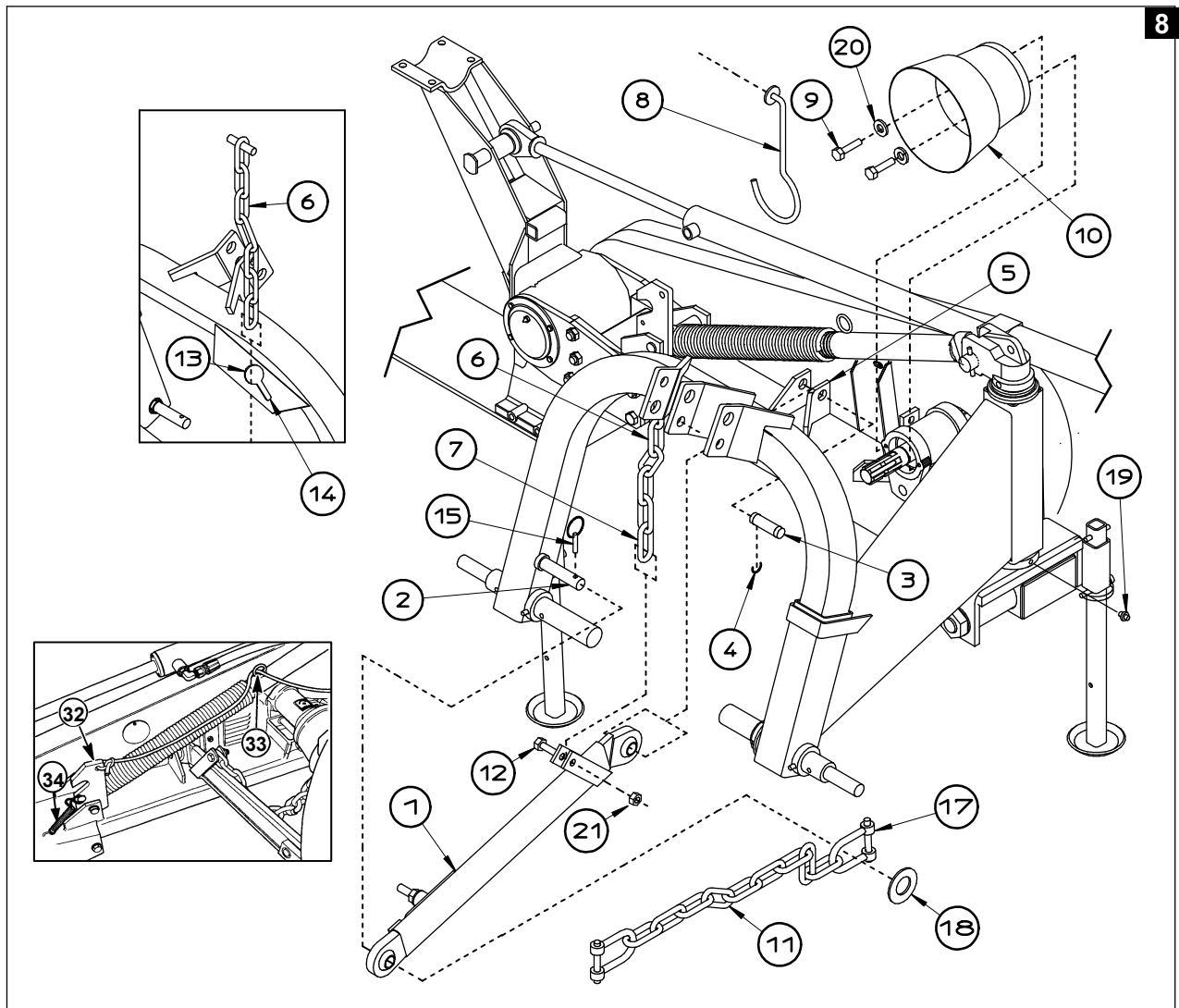

- 4) Use screw 12 M 12 x 55 (D 1/2" x 2" 10/64) and nut 21 to fasten ring 7 on chain 6 to safety bar
- 5) Use screws 9 M 8 x 12 (D 5/16" x 1/2") and flat washer 20 ($\varnothing 8.5 / \varnothing 24$) to assemble casing 10.
- 6) Insert cardan support 8 into one of the holes not used by the pin of the third point.
- 7) Mount grease nipple (M6) 19.
- 8) Tie the rope to the safety latch 32 and then thread it through the steel circle 33 (see figure detail).
- 9) Remember to link the spring 34 to transport hook 32 (see figure detail).
- 10) For the following steps proceed as shown for figures 5 and 6.



Make sure that when assembly operations have been finished, all nuts and bolts are correctly screwed up.

6. Instructions for installation

6.1 How to adapt to the tractor

The machine can be adapted to tractors with various gauges by placing the two hoist arms as shown in fig.9, so that height A is about 10 cm (4 inches) when the machine is in the work position (see 7.1):

The hoist pins of the machine with 4-5 disks (fig.2) are different from those of the machine with 6-7 disks (fig.7).

The pins for the machine with 4-5 disks are suitable for 1st and 2nd class couplings (22mm/0.86 inches and 28mm/1.1 inches) whereas the pins for the machine with 6-7 disks can be used only with a 2nd class coupling.

In order to obtain the various positions shown in fig.9 proceed as follows:

- a) with 4-5 disks turn the pin that is not holding the safety hook in place correctly upside down and remove or insert adjuster bush 5 into the other pin.
- b) with 6-7 disks turn the pins upside down in the respective slots and fasten into position with screws 6 and 9 (fig. 7) in one of the adjustment holes on the lateral projecting part of the pin.

The third point has to be adjusted so that axle E in fig. 14 is vertical.

- 1) Start up the hydraulic hoist and raise the drawbar slightly.
- 2) Adjust and stabilise the lower hoist arms of the tractor on each side.
- 3) If necessary, move the vertical movement adjuster tie rod on the hoist arms until both ball-and-socket joints are at the same height above ground.
- 4) Use peg 3 to fasten the rest feet (fig. 10) in position 1.
- 5) Connect hoist chain 2 in figure 14 to the tractor for the time being.

6.2 How to adapt the cardan shaft

In order to make sure that the cardan shaft is the right length compared with the tractor power

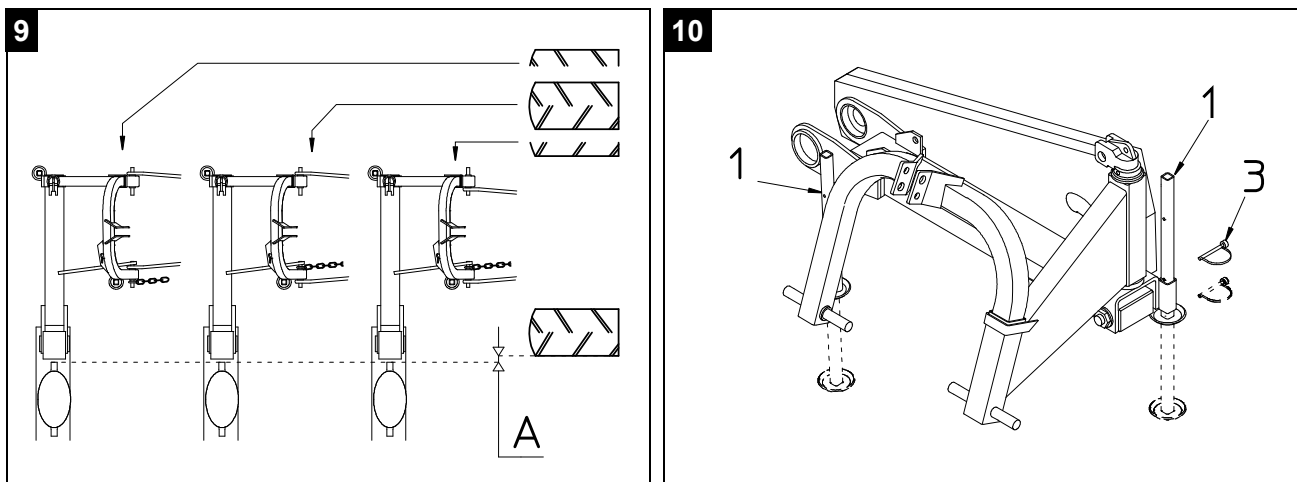

takeoff (with the machine already attached to the tractor), proceed as follows:

- 1) Remove the two cardan joint axle shafts and insert them separately on the 2 power takeoffs with the clutch on the side of the mowing machine.
- 2) Place the two axle shafts one alongside the other (fig. 11).
- 3) Check that when the cardan shaft is stretched to its minimum length (repeatedly raise and lower the machine to find this position), the tubes do not touch the bottom, so that there is always a minimum clearance of 20 mm (0.79 inches).
- 4) If necessary, reduce the two axle shafts as well as the two axle shaft protections by the same amount (keeping the above-mentioned conditions), and take care to clean and lubricate them before starting work.
- 5) When the cardan shaft is stretched to its maximum length (with the safety device released), the cardan tubes must remain inserted at least 10 cm (4 inches).
- 6) Use the relevant chains to fasten the outer cardan shaft protection

6.3 Road use

Strictly comply with the road traffic regulations in your country.

In order to put the machine in the transport position when the machine is on the ground and is connected to the tractor, proceed as follows:

- 1) Open the front pivoting protection (canvas support).
- 2) Use the tractor hoist to raise the machine off the ground.
- 3) Lift the disk carrier bar vertically along the entire cylinder run until pin 2 entirely enters the slot on hook 1 (fig.12 item A).
- 4) Pull out the cylinder shaft slightly until it is well fastened.

Reference: picture 8

Settle chain 6 in order to block the frame's swinging, when the tractor lifts the disc mower.

Insert last ring 7 in the relevant hitch of bar 1 and block it with screw 12 and the specially provided nut. At this point insert a chain's ring in slot 14 of hole 13 (this last one is settled in the 3 point hitch). The choice of the ring, that has to be inserted in the slot, depends on the kind of tractor. This choice must assure a certain safety distance from the ground, during the transport.

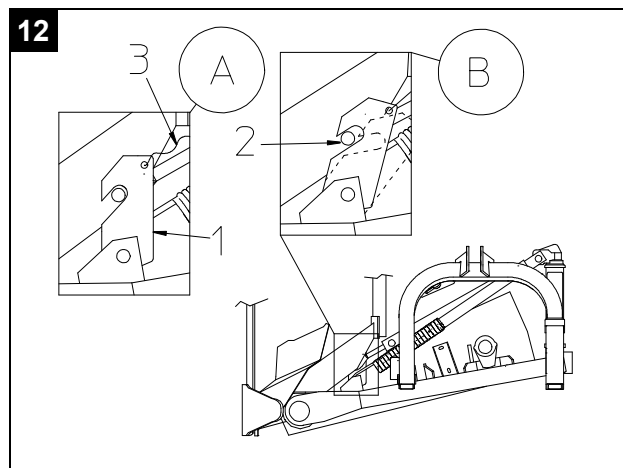
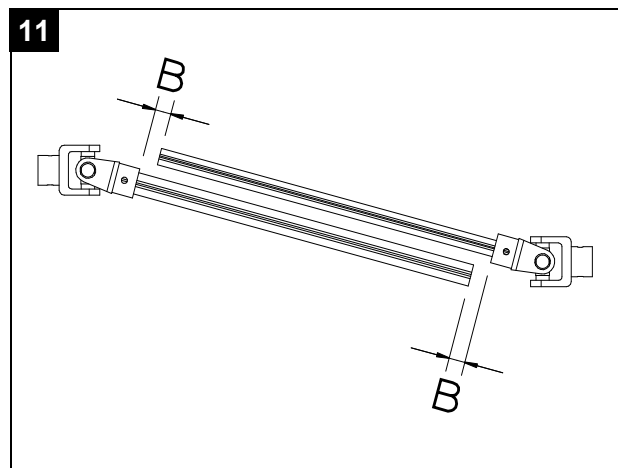

7. Adjustments and set-up

7.1 Belt tension

Belt tension must be checked regularly particularly during the first few hours of use. In order to adjust tension proceed as follows (fig. 13):

- 1) Loosen the nuts 1.
- 2) Move the pulley and use nuts 1 to increase belt tension until distance C (visible through opening 2 as shown in fig.13) is about 20 mm (0.8 inches) when pressure is applied to the central line.
- 3) Tighten the nuts 1 in order to fasten the pulley hub and finally check that tension is correct.

If a belt has to be replaced, all belts should be replaced at the same time.

The belts must be loosened at the end of the season.

7.2 Cutting height

The cutting height can be adjusted by using turnbuckle 1 on the third tractor point to vary the tilt of the knives compared to the ground (distance F in fig. 14).

Cutting height may vary within the range of 16/60 mm (0.63/2.36 inches) even though uneven land may influence these values.

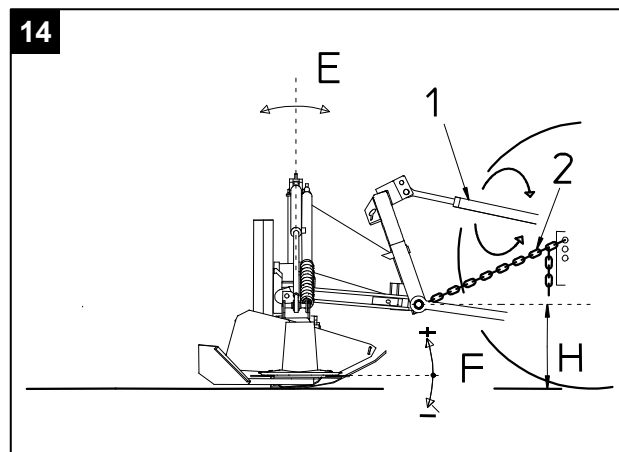
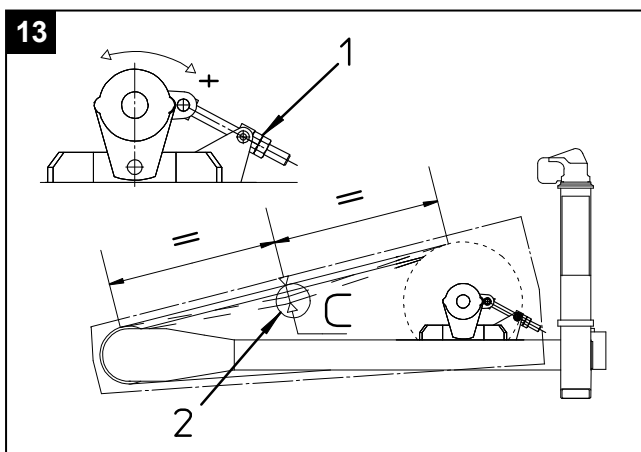

8. Use

8.1 Work position

To move from the transport position (see 5.3) to the work position proceed as follows:



Make sure that no person or object is standing within the turnover range of the disk carrier bar.

- 1) Send the cylinder shaft backwards slightly but keep rope 3 stretched until pin 2 (fig.12 item B) is unhooked.
- 2) Take out the cylinder shaft until the disk carrier bar is horizontal.
- 3) Use the tractor hoist to lower the machine; fasten adjustment chain 2 (fig.14) above the ground so that distance H is about 50 cm (19.7 inches).



Make sure that adjustment chain 2 (fig.14) is always well stretched when machine is working to prevent pin 2 (see fig.8) from damage.

- 1) Lower the protection plate and check that the cardan shaft is inserted into the machine power takeoff.

8.2 Mowing

- 1) Before starting to mow, place the machine on the ground so that the disk carrier bar is horizontal.
- 2) Before starting the machine, make sure that the knives are well sharpened, particularly if the grass is thin, dry or sparse.
- 3) Switch on power takeoff rotation and gradually accelerate.
Machine input rotation speed must be about 540 revs/minute.

If the bar is working for long periods on sloping ground, we advise holding it in a horizontal position for a few minutes every half hour of work.



Make sure there are no persons nearby, particularly behind the disk carrier bar discharge area. Always check before you start mowing that the protection plate is lowered all the way round the machine.

9. Faults: reasons and remedies

9.1 The disk carrier bar vibrates too much during work:

the nylon bushings of the joints in question are overworn or completely worn out.

⇒ replace the bushings;

the pins and/or respective bushings/bearings of the joints in question are overworn.

⇒ replace the worn-out parts and lubricate regularly;

the outer conveyor is too slack

⇒ check that it is fastened correctly and check the nylon bushing.

9.2 The disk carrier bar does not adapt correctly to uneven ground:

the height of the tractor coupling plate is not adjusted correctly

⇒ readjust as specified in point 4.1 (in particular check that both ball-and-socket joints are the same height above ground);

the machine joints resist free rotation

⇒ clean and lubricate the parts in question.

9.3 The disk carrier bar is not raised parallel to the ground:

the entire machine is leaning to one side

⇒ check that both hoist ball-and-socket joints are at the same height above ground;

the transverse slant of chain 6 (figs.3-8) is not adjusted correctly

adjust the chain to the correct length and fasten one of the circlips into slot 14 (figs.3-8)

9.4 Earth accumulates between two sliding blocks in the front part of the disk carrier bar:

The ground is exceptionally wet;

the bar presses too hard on the ground

⇒ use the tractor hoist to raise the machine higher above the ground and then readjust the chain giving minimum height above ground;

the disk carrier bar tilts too far forward

⇒ adjust the tilt of axle E (fig.14) by moving turnbuckle 1 on the third point.

9.5 Safety device 1 (figs. 3-8) often unhooks under impact:

The rubber buffer is worn out or is not adjusted correctly.

⇒ check the condition of the rubber buffer and if necessary, tighten the relevant screw very carefully (danger of unhooking when it receives blows that are too strong for the machine structure) until unhooking occurs at reasonable intervals only.

9.6 The stubble is too high or too sparse:

The disk carrier bar does not tilt correctly (axle E in fig.14)
 ⇒ use turnbuckle 1 on the third point to adjust the tilt.

9.7 The stubble is not the same height all along the cutting width:

the disk carrier bar tilts too much

⇒ reduce the tilt of the disk carrier bar (fig.14);

the knives are over worn

⇒ replace the knives;

power takeoff speed is insufficient

⇒ increase power takeoff rotation speed up to, but not over, 540 revs/min;

forward movement speed is too fast

⇒ reduce tractor speed.

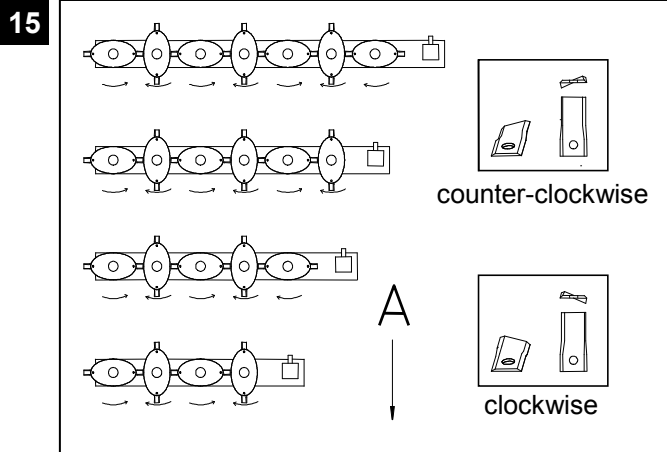

9.8 The forage is pushed forward before being cut:

the ventilating effect of the knives is too strong

⇒ reduce power takeoff rotation speed and increase tractor forward movement speed.

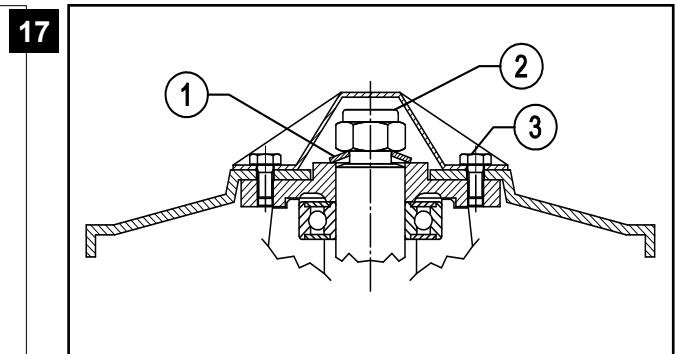
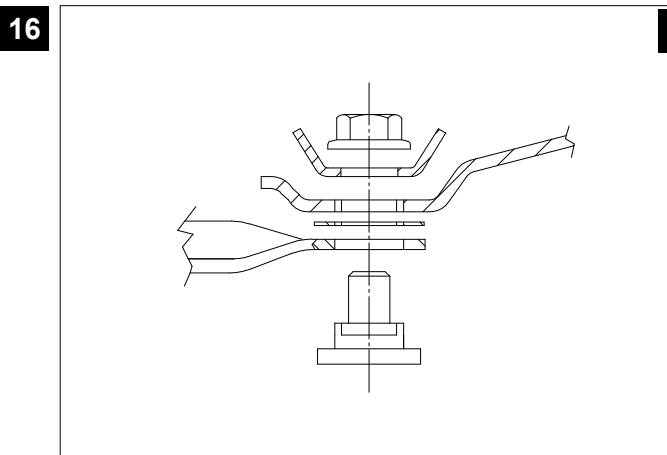

10. Maintenance

10.1 How to fasten cutting devices

After they have been used the first time, the disks, knives and relevant parts to fasten them must be controlled regularly every 15-20 working hours. More frequent checks will have to be made if mowing is carried out on stony ground and after impact with an obstacle.

The oval disks are splined to a shaft and have to be positioned so that the main axle is at right angles with those next to it (fig.15).

The knives are fastened by means of a special self-tapping screw and an M12 nut (fig.16); the nut must be tightened with a 16 kgm (160 Nm) torque.

Cupped washer 1 (fig.17) must be mounted with its concavity facing downwards. The self-locking nut 2 must be tightened with a dynamometric spanner set at 32 kgm (320 Nm) torque.

The six screws 3 must be tightened with a dynamometric spanner set at 70-80 Nm torque.

Pay attention to the direction of disk rotation. Worn knives can be replaced by carefully looking at fig.15 (A is the work moving direction); the second cutter (if still in good condition) can be used by putting it back turned up-down at the same side of the disk. If worn knives are used to mow, the cut will be less precise and more power will be used.

10.2 How to check the mowing devices

The knives should be replaced when:

- ⇒ the width of the knife at point B=1 cm (0.4 inches) from the edge of the disk is 3/4 of the original width A (fig.18).
- ⇒ the oval shape of the hole is more than a distance of C=2mm (0.08 inches) of the size of the original hole (fig.19).

The clamp parts should be replaced when:

- ⇒ the screw to fasten the knives is bent or too worn out below the head (fig.20).
- ⇒ the self-tapping layer 1 of the screw to fasten the knives is missing or too worn out; we advise changing the screw after it has been tightened 5 times.
- ⇒ the clamp screw is worn down where it holds the knife to a distance of E higher than or equal to 3 mm (0.12 inches) (fig.22).
- ⇒ the height of the lock nut at any point whatsoever is less than or equal to 1/2 of the total nut height (fig.23).

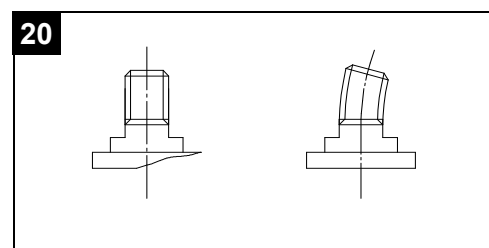
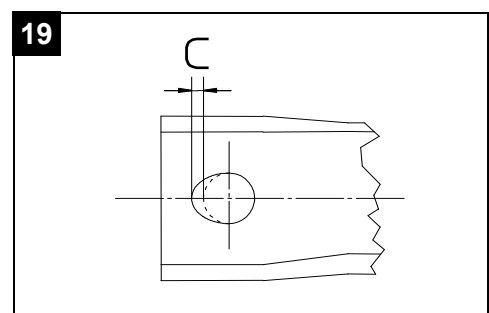
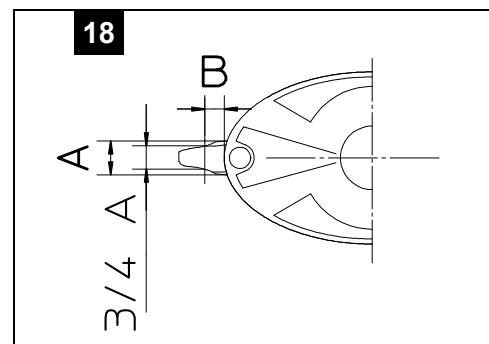



Worn out or damaged pieces must be replaced with original spare parts.

10.3 General maintenance

Before carrying out any cleaning or maintenance operation etc. comply with all the safety warnings given in this use and maintenance handbook. Before carrying out any operation directly, first:

- switch off the engine;
- remove the key from the dashboard and put the brake on the tractor;
- release circuit pressure;
- check that the mower is stable.



Do not carry out any operation if the machine is moving.

The following points should be checked on each new machine 8 working hours:

- the screws are correctly tightened;
- the tension of all the belts;
- that no parts of the hydraulic system are leaking;
- that the driving gear parts are correctly lubricated.

Carry out the following checks regularly particularly at the beginning of each season:

- check/replace the oil, lubricate/grease each point necessary, according to the instructions;
- check wear and tear of the knives and respective clamp parts;
- check wear and tear of protection parts;
- reset correct belt tension;
- check that all the screws are tightened correctly.

Before beginning to mow, make sure that the machine is working correctly and there are no vibrations.

10.4 Lubrification

Change the oil in the disk carrier bar and the over-gear box after the first 50 hours use. After this first change, we advise changing the oil every 100 working hours or at least once a year.

- The cardan shaft should be greased regularly as shown in fig.24.
- The joints, supports, hinges, and points equipped with lubricator should be lubricated or greased

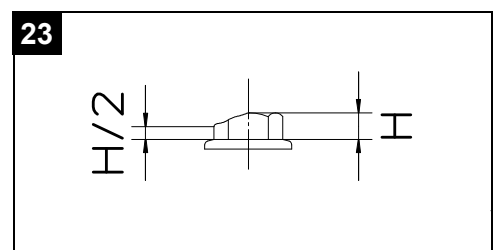
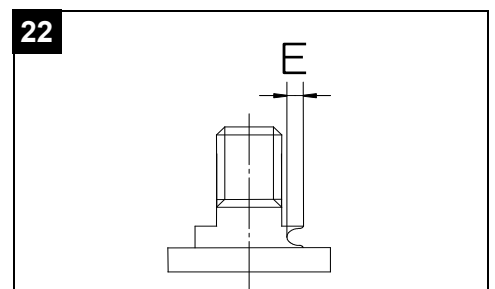
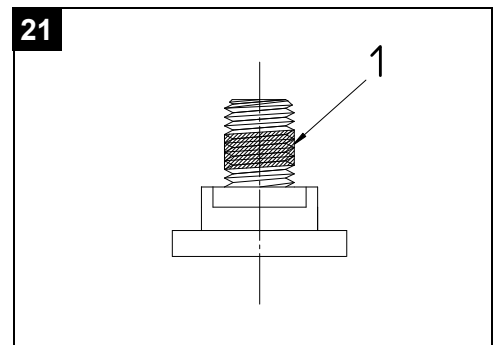

frequently, at least every 20 working hours (fig.27).



When in use, check the oil levels every day and top up if necessary.

10.4.1 Over-gear box (fig.25)

1= drain/loading cap with level rod

2= breather cap on disk carrier bar.

Use SAE EP 80 W 90 oil in the quantities shown in the table. Check the level with the special rod on the drain/loading cap when the bar is lying horizontally.

Oil can be drained through the hole in cap 1 when the bar is vertical.

10.4.2 Disk carrier bar (fig.26)

1= loading cap - level cap

2= drain cap

Use SAE EP 80 W 90 oil in the quantities shown in the table.

Oil is loaded and the oil level is checked when the disk carrier bar is vertical (it must have been in the vertical position for at least 5 minutes).

24

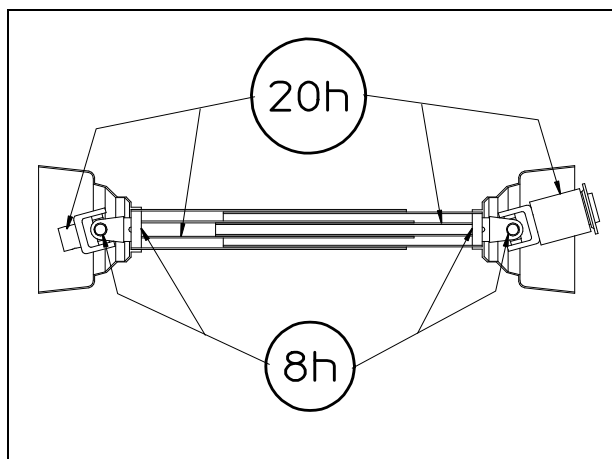

25

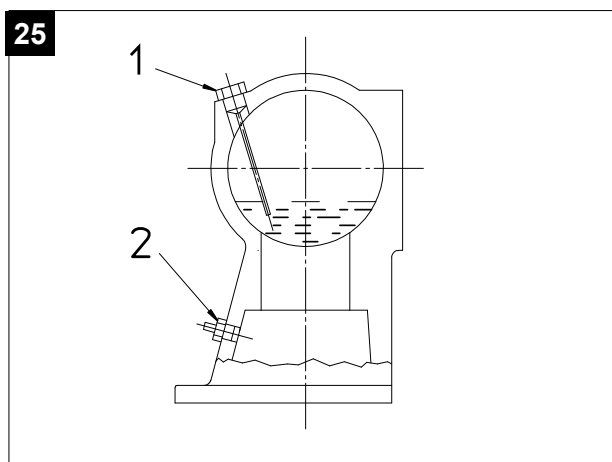

26

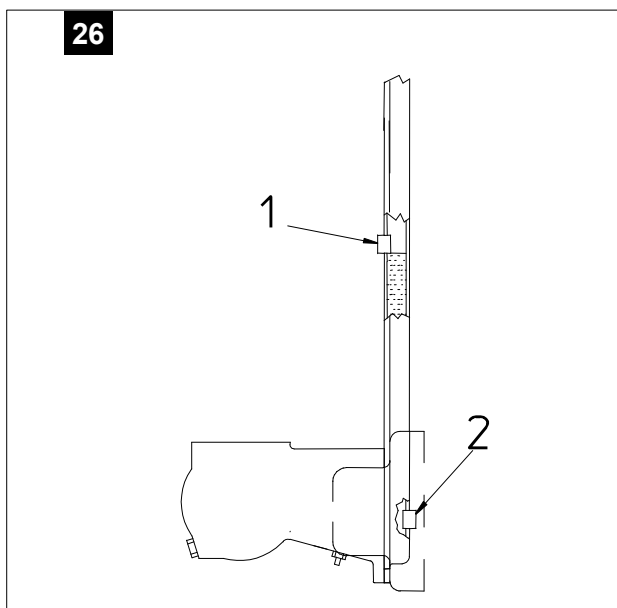

In order to fill up the oil unscrew both caps 1 (filling and level) and pour in the amount shown or the amount needed to top up the level through the hole in cap 1 (tilt the bar slightly if necessary so it is easier to pour in the oil) until the level of cap 1 is reached.

	litres	Gall. UK	Gall. USA
Over-gear box	0,7	0.16	0.19
4 disk bar	1,6	0.36	0.43
5 disk bar	2.3	0.50	0.60
6 disk bar	2,9	0.64	0.77
7 disk bar	3,6	0.80	0.95

10.5 End of season storage

At the end of the season we recommend storing the machine with the bar lying horizontally after having cleaned it carefully. You should also:

- lubricate and grease each point shown in this use and maintenance handbook;
- protect the areas subject to rubbing with a layer of anti-rust paint;
- loosen the trapezoidal belts and check that the protection plate is lying flat.

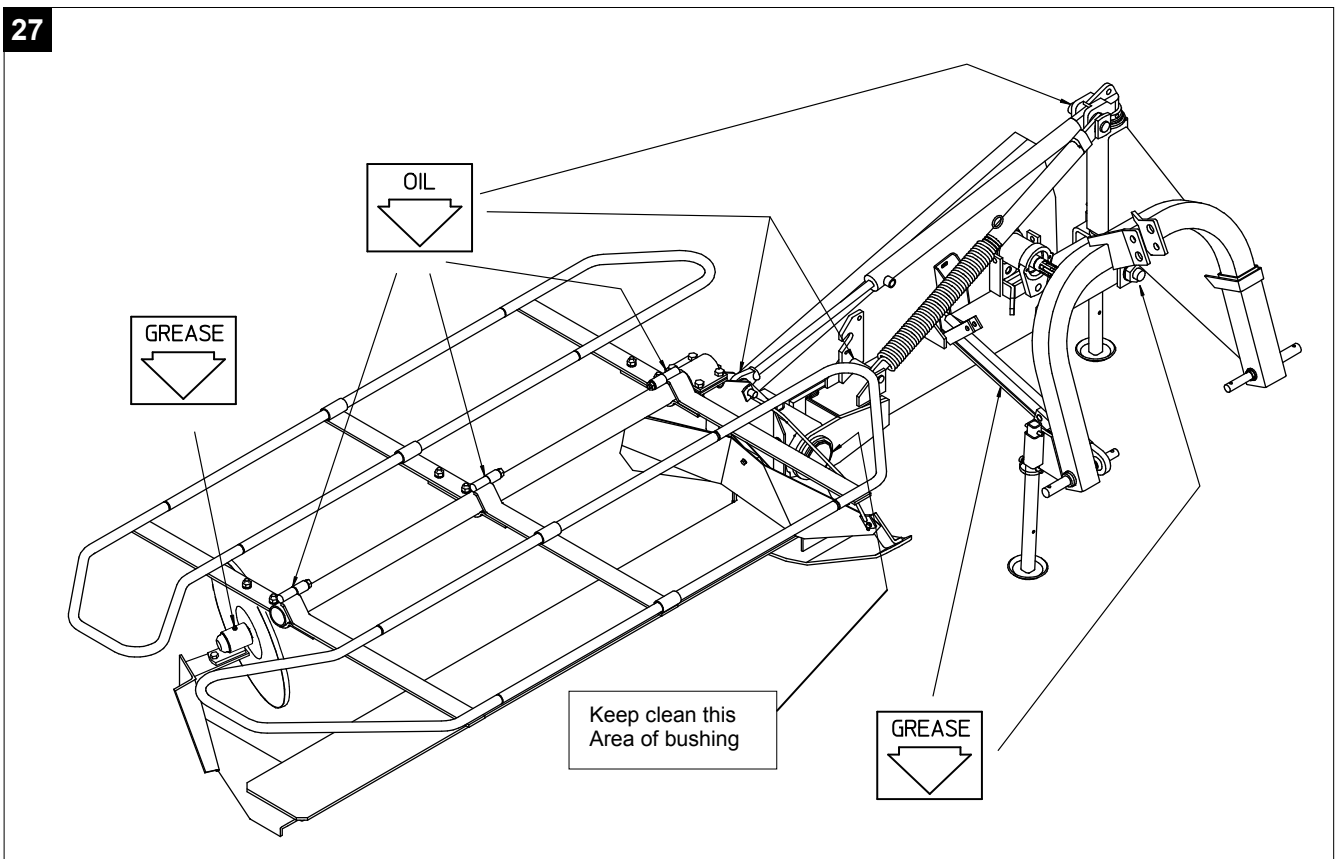

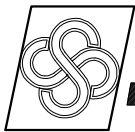

sitrex AGRICULTURAL MACHINERY [®] Spa .

Zona Industriale-Viale Grecia, 8
06018 TRESTINA-(Perugia)-ITALY
Tel. +39.075.8540021-Telefax +39.075.8540523
e-mail: sitrex@sitrex.it www.sitrex.com

