



DualVee[®] Series

GUIDE WHEELS AND TRACK

EXPERTLY DESIGNED, DELIVERED TO PERFORM

EXPERTLY DESIGNED, DELIVERED TO PERFORM

Powered by nearly 70 years of relentless problem-solving and steadfast reliability, Bishop-Wisecarver delivers innovative motion solutions around the world that thrive in harsh and extreme conditions. Our linear and rotary motion solutions, custom complex assemblies, and embedded intelligence systems lead the manufacturing industry, and they are backed by The Signature Experience promise of expert guidance, confidence and customer satisfaction.

PERFECT FOR HARSH AND EXTREME ENVIRONMENTS

When you purchase from Bishop-Wisecarver, you aren't just getting a product that works; you're getting products, systems, and industry-leading expertise you can trust, especially in harsh conditions and critical environments—always exceeding our customers' reliability requirements.

Our Motion Products and Solutions Are Also Perfect For:



**HARSH
ENVIRONMENTS**



LONG LENGTH



LOW NOISE



**HIGH/LOW
TEMPERATURE**



**LOW TOTAL COST
OF OWNERSHIP**



**SMOOTH, LOW
FRICTION MOTION**



**MOIST
ENVIRONMENTS**



FOOD GRADE



CLEAN ROOM



VACUUM

DESIGN AND BENEFITS

- Double row angular contact ball bearing arrangement for dynamic loading
- 90° dual vee design allows for natural wiping action and clearing of debris
- Eccentric wheels, bushings, & journals allow for fitting without the need of high cost precision machining for mounting holes
- Wheels & track are replaceable, making maintenance simple and easy
- Sealed, shielded, or seal/shield combination to protect against contamination such as dirt, dust, metal chips, wood chips, textile fiber, food, slurry and deionized water
- Smooth, low friction motion
- Unlimited butt-joining of track for long travel lengths, speeds up to 5.5 m/s and acceleration up to 5 g's
- Temperature ranges from -94°F to +500°F, -70°C to +260°C
- Track can be mounted to a variety of base materials without the need for precision ground or machined surfaces

Example mounting and running surfaces

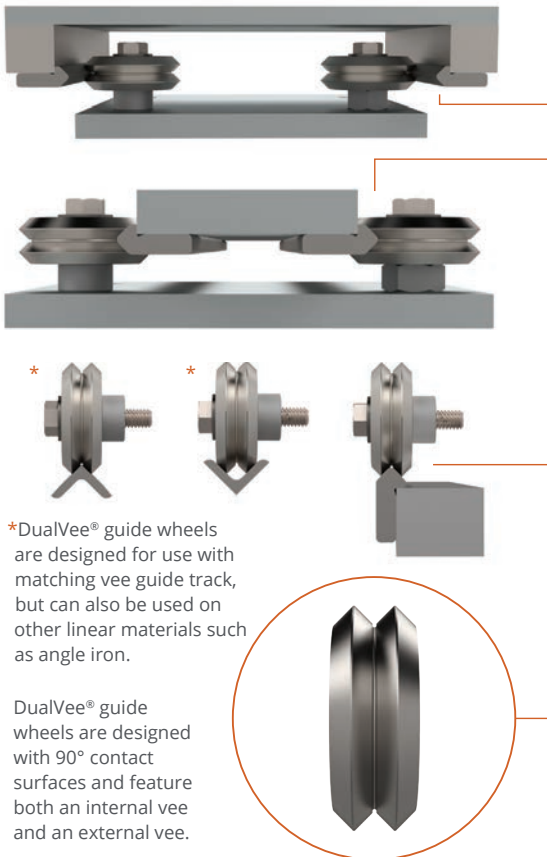

TABLE OF CONTENTS

DualVee® Guide Wheels	4
Original Guide Wheels	5
SWA Series	6
SWS Series	7
SWI Series	8
Bushings	9
Journals	11
Track Single Edge	12
Wheel Covers	13
Track Lubricators	15
Track Double Edge	16
Track Support Double Edge	17
MinVee®	18

Need Help

Application + Design Assistance

925.439.8272

3D Modeling + CAD Drawing

BWC.com

DUALVEE® GUIDE WHEELS

For Any Application

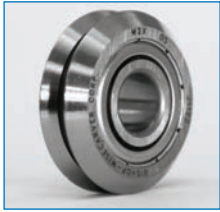

Carbon Steel



Stainless Steel



**Stainless Steel
High Temperature**



**Stainless Steel
Low Temperature**



**Studded Wheel
Assemblies**

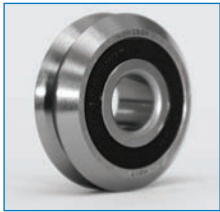

**Stainless Steel
Washdown Wheels**

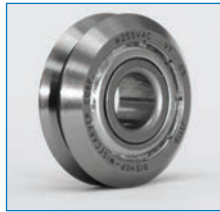

**Stainless Steel
Vacuum Wheel**



**Stainless Steel
Food/Pharma Wheel**



**Polymer Studded
Wheel Assemblies**

WHEEL VERSION	PART NUMBER SCHEME	APPLICATION CONDITIONS	APPLICATION EXAMPLES	AVAILABLE SIZES	PROTECTION	WHEEL MATERIAL	BALL RETAINER MATERIAL	GREASE	TEMPERATURE RANGE
									(°F)
Original Guide Wheels Carbon	W_	<ul style="list-style-type: none"> General purpose Factory floor conditions 	<ul style="list-style-type: none"> Automation Automotive Woodworking Printing Packaging Paper/textiles 	0, 1	Shield	52100 Steel	Nylon 6,6	Shell Alvania EP2	-31° to +248°
	W_X			0,1,2, 3, 4, 4XL	Seal/shield	52100 Steel	Nylon 6,6	Shell Alvania EP2	-22° to +212°
Original Guide Wheels Stainless	W_SSX	<ul style="list-style-type: none"> Corrosive conditions 	<ul style="list-style-type: none"> Medical Laboratory Food & beverage 	1	Seal	440C Stainless	Nylon 6,6	Shell Alvania EP2	-22° to +212°
				2, 3, 4, 4XL	Seal/shield				
Studded Polymer Wheels	SWI_P	<ul style="list-style-type: none"> Corrosive conditions Low noise requirements 	<ul style="list-style-type: none"> Electronics Medical Laboratory 	0,1, 2	Shield	Polymer (overmold) 440C Stainless	300 Stainless	Kluberplex BEM034-132	-4° to +248°
Vacuum Wheels	W_SSVAC	<ul style="list-style-type: none"> Vacuum environments 	<ul style="list-style-type: none"> Material science 	1, 2	Shield	440C Stainless	304 Stainless	Lubcon Ultratherm 2000	-31° to +482°
Washdown Wheels	WDW_SSX	<ul style="list-style-type: none"> Washdown conditions Hygienic environments 	<ul style="list-style-type: none"> Food processing Food packaging 	2, 3	Double seal	440C Stainless	Nylon 6,6	Klubersynth UH1 14-151	-22° to +212°
Food/Pharma Wheels	W_SSXH1	<ul style="list-style-type: none"> Washdown conditions Food equipment Pharma equipment 	<ul style="list-style-type: none"> Food processing Food packaging Pharmaceutical 	2, 3	Seal/shield	440C Stainless	Nylon 6,6	Klubersynth UH1 14-151	-22° to +176°
Extreme Temperature Wheels	W_SS227	<ul style="list-style-type: none"> High temp. conditions Corrosive conditions 	<ul style="list-style-type: none"> Baking Welding Plasma cutters 	0,1, 2, 3, 4	Shield	440C Stainless	304 Stainless	Krytox® GPL227	-22° to +500°
	W_SS300	<ul style="list-style-type: none"> Low temp. conditions Subzero conditions Corrosive conditions 	<ul style="list-style-type: none"> Aerospace Refrigeration Flash freezing 	0,1, 2, 3, 4	Shield	440C Stainless	304 Stainless	Kluber Isoflex PDL 300A	-94° to +230

Shield material is 300 series stainless steel

Seal material is NBR

Seal/shield materials are 300 series stainless steel and NBR combination

Wheels can be assembled with user specified grease lubricants, call for more information

Shell Alvania is owned by Royal Dutch Shell

Ultratherm is owned by Lubcon

Kluberplex, Klubersynth, and Isoflex are owned by Kluber Lubrication

Krytox® is owned by DuPont

ORIGINAL GUIDE WHEELS

Product Features

From factory automation projects to OEM designs, **DualVee Motion Technology®** components and assemblies provide the design flexibility for virtually any guided motion application. Based on the **DualVee®** guide wheel, this technology offers a level of reliability that is unmatched in the industry.

DUALVEE WHEEL SIZE	OUTER DIAMETER	WIDTH	BORE DIAMETER	VEE RADIUS INSIDE	VEE RADIUS OUTSIDE	WEIGHT (g)
	D	W	B	VRI	VRO	
	0	Ø0.584 [Ø14.83]	.250 [6.35]	Ø.1575+0.000/-0.0003 [Ø4.000+0.000/-0.008]	.234 [5.94]	
1	Ø0.771 [Ø19.58]	.310 [7.87]	Ø.1875+0.000/-0.0003 [Ø4.760+0.000/-0.008]	.313 [7.95]	.468 [11.89]	11.1
2	Ø1.210 [Ø30.73]	.438 [11.13]	Ø.3750+0.000/-0.0003 [Ø9.530+0.000/-0.008]	.500 [12.70]	.719 [18.26]	39.0
3	Ø1.803 [Ø45.80]	.625 [15.88]	Ø.4724+0.000/-0.0003 [Ø12.000+0.000/-0.008]	.750 [19.05]	1.063 [27.00]	130.2
4	Ø2.360 [Ø59.94]	.750 [19.05]	Ø.5906+0.000/-0.0003 [Ø15.001+0.000/-0.008]	1.000 [25.4]	1.375 [34.93]	276.0
4XL	Ø2.968 [Ø75.39]	1.000 [25.4]	Ø.8661+0.000/-0.0004 [Ø22.000+0.000/-0.008]	1.250 [31.75]	1.750 [44.45]	575.0

DIMENSIONS

MATERIALS INCLUDE

Stainless steel | Carbon steel

Values are in inches [millimeters]

DUALVEE WHEEL SIZE	WORKING RADIAL LOAD CAPACITY L_R		WORKING AXIAL LOAD CAPACITY L_A	
	N	lbf	N	lbf
	0	650	146	123
1	1220	274	252	57
2	2650	596	625	141
3	5900	1326	1701	382
4	9700	2181	4001	900
4XL	14300	3215	6552	1473

LOAD CAPACITIES

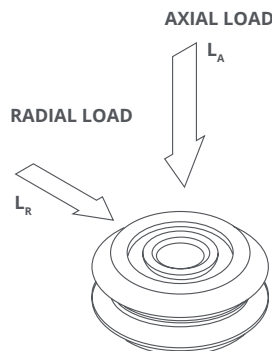
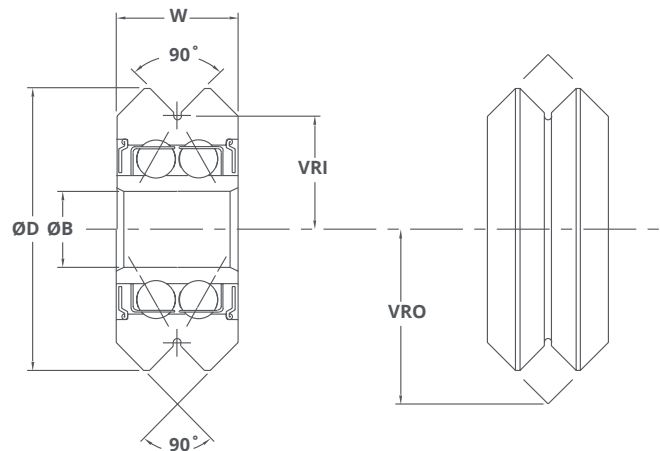

Working Load Capacities

Working load capacities are based on empirical data on guide wheels used in general applications with static and dynamic load conditions. Guide wheels can routinely achieve travel life of one million cycles or higher when these specified load capacities are observed.

Specific load ratings vary by wheel version, see the Technical Data catalog for details.

SWA SERIES

Studded Guide Wheels | Thru-Hole Style

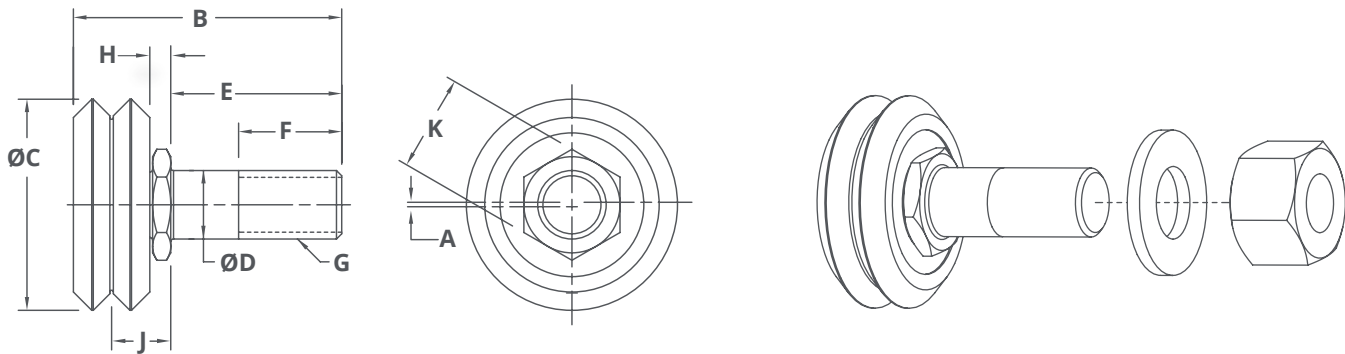

Dimensions

SIZE	ADJUSTABILITY	ECENTRIC OFFSET	OVERALL LENGTH	WHEEL DIAMETER	JOURNAL DIAMETER	JOURNAL LENGTH	THREAD LENGTH	THREAD	HEX THICKNESS	VEE HEIGHT	HEX SIZE
		A	B	C	D ¹	E	F	G	H ²	J	K
0	Concentric	---	0.74 [18.8]	Ø0.584 [Ø14.83]	Ø.1566 [Ø3.978]	.39 [9.9]	.24 [6.1]	M4 x 0.7	.080 [2.03]	.205 [5.2]	.433 [11.0]
	Eccentric	.024 [.61]									
1	Concentric	---	1.00 [25.4]	Ø.771 [Ø19.58]	Ø.2352 [Ø5.974]	.59 [15.0]	.35 [8.9]	M6 x 1.0	.083 [2.11]	.238 [6.05]	.472 [12.0]
	Eccentric	.024 [.61]									
2	Concentric	---	1.54 [39.1]	Ø1.210 [Ø30.73]	Ø.3926 [Ø9.972]	.98 [24.9]	.59 [15.0]	M10 x 1.5	.104 [2.64]	.323 [8.2]	.551 [14.0]
	Eccentric	.038 [.97]									
3	Concentric	---	1.967 [49.96]	Ø1.803 [Ø45.80]	Ø.4711 [Ø11.966]	1.18 [30.0]	.71 [17.9]	M12 x 1.75	.137 [3.48]	.450 [11.4]	.748 [19.0]
	Eccentric	.060 [1.50]									
4	Concentric	---	2.477 [62.92]	Ø2.360 [Ø59.94]	Ø.6284 [Ø15.961]	1.58 [40.1]	.95 [24.1]	M16 x 2.0	.122 [3.10]	.497 [12.6]	.866 [22.0]
	Eccentric	.060 [1.50]									

Notes:

1. Tolerance for Journal Diameter (D) are: +.0000/-0.0007 [+0/-0.017]
2. Tolerance for Hex Thickness (H) are: +/-0.001 [+/-0.02]
3. Stud material is AISI 303 stainless steel.
4. Nut and washer material are 18-8 stainless steel.
5. Total weight and load capacity are based upon the wheel version selected, see the Technical Data catalog for additional specifications.
6. See the Technical Data catalog for additional wheel dimensions and specifications.

Part Number Scheme:

PREFIX	ADJUSTABILITY	SIZE	WHEEL VERSION
SWA	C	0	Blank
	E	1	X
		2	SSX
		3	SSXH1
		4	SS227
			SS300
			SSVAC
			WD#SSX*

Part Number Example:

SWAE3SS227 = Studded Wheel Assembly, Eccentric, Size 3, Corrosion Resistant SS227 High Temperature Wheel Version

*Washdown wheel version uses a different Part Number Scheme: SWA_WD#SSX. The underscore is for the adjustability variable.

Polymer wheel versions are unavailable in the SWA series.

SWS SERIES

Studded Guide Wheels

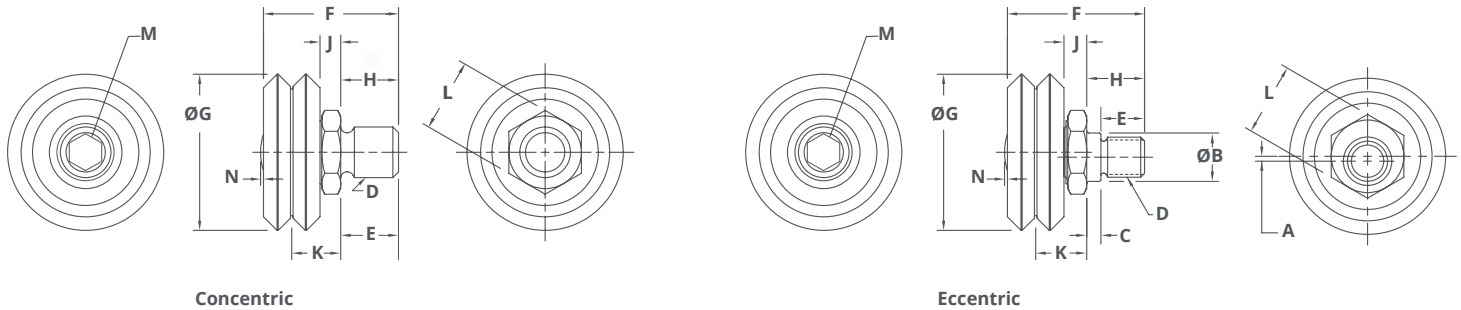

Dimensions		ECCENTRIC OFFSET	ECCENTRIC SHOULDER DIAMETER	ECCENTRIC SHOULDER LENGTH	THREAD	THREAD LENGTH	OVERALL LENGTH	WHEEL DIAMETER	JOURNAL LENGTH	HEX THICKNESS	VEE HEIGHT	HEX SIZE	OPTIONAL END HEX SIZE	MATERIAL PROTRUSION
SIZE	ADJUSTABILITY													
0	Concentric	---	---	---	M6 x 1.0	.300 [7.62]	.667 [16.95]	Ø0.584 [Ø14.83]	.300 [7.62]	.117 [2.97]	.242 [6.15]	.375 [9.53]	---	0.017 [.43]
	Eccentric	.024 [.61]	Ø.219 [Ø5.56]	.085 [2.16]	M5 x 0.8	.215 [5.46]								
1	Concentric	---	---	---	M8 x 1.25	.319 [8.10]	.761 [19.33]	Ø.771 [Ø19.58]	.319 [8.10]	.132 [3.36]	.287 [7.30]	.4375 [11.113]	---	0.025 [.64]
	Eccentric	.024 [.61]	Ø.248 [Ø6.30]	.085 [2.16]	M6 x 1.0	.183 [5.94]								
2	Concentric	---	---	---	M10 x 1.5	.448 [11.38]	1.046 [26.57]	Ø1.210 [Ø30.73]	.448 [11.38]	.160 [4.07]	.379 [9.63]	.5625 [14.288]	.236 [6.0]	---
	Eccentric	.038 [.97]	Ø.375 [Ø9.53]	.110 [2.79]	M8 x 1.25	.338 [8.59]								
3	Concentric	---	---	---	M12 x 1.75	.595 [15.11]	1.444 [36.68]	Ø1.803 [Ø45.80]	.595 [15.11]	.224 [5.69]	.537 [13.63]	.750 [19.05]	.315 [8.0]	---
	Eccentric	.059 [1.50]	Ø.422 [Ø10.72]	.170 [4.32]	M10 x 1.5	.425 [10.80]								
4	Concentric	---	---	---	M14 x 2.0	.748 [19.00]	1.767 [44.88]	Ø2.360 [Ø59.94]	.748 [19.00]	.269 [6.83]	.644 [16.36]	.875 [22.23]	.394 [10.0]	---
	Eccentric	.079 [2.01]	Ø.500 [Ø12.70]	.177 [4.50]	M12 x 1.75	.571 [14.50]								

Notes:

1. Tolerances for Eccentric Hex Diameter (B) are: +.002/-0.00 [+/.05/-0.00]
2. Tolerance for Shoulder Thickness (J) are: +/-0.01 [+/-0.02]
3. End hex provides easy external means for adjustment.
4. Stud material is AISI 303 stainless steel.
5. See the Technical Data catalog for recommended mounting geometry.

Part Number Scheme:

PREFIX	ADJUSTABILITY	SIZE	WHEEL VERSION	OPTION END HEX	SUFFIX
SWS	C	0	Blank	Blank	A
	E	1	X	H	
		2	SSX		
		3	SSXH1		
		4	SS227		
			SS300		
			SSVAC		
			WD#SSX*		

Part Number Example:

SWSE2SS300HA = Studded Wheel Swaged, Eccentric, Size 1, Corrosion Resistant SS300 Wheel Version, with Optional End Hex

*Washdown wheel version uses a different Part Number Scheme: SWS_WD#SSXA. The underscore is for the adjustability variable.

Polymer wheel versions are unavailable in the SWS series.

SWI SERIES | POLYMER

Studded Guide Wheels

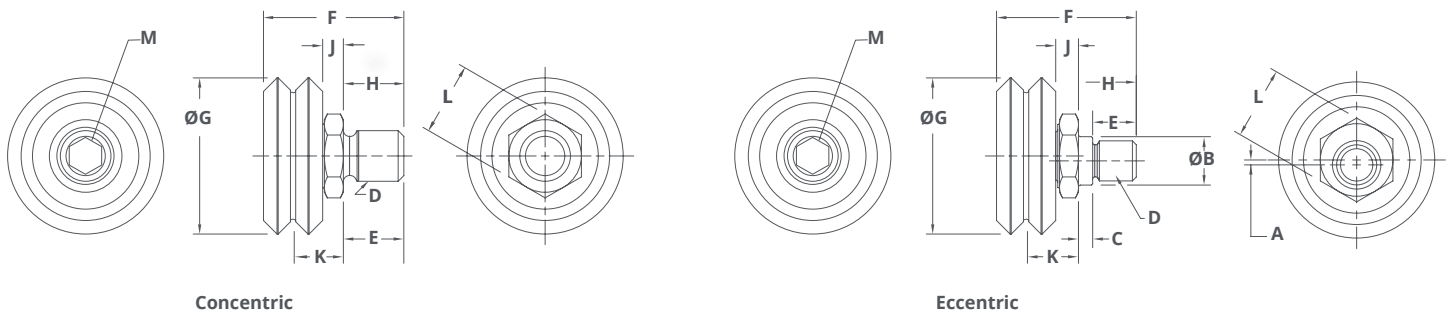

Dimensions

SIZE	ADJUSTABILITY	Eccentric Offset	Eccentric Shoulder Diameter	Eccentric Shoulder Length	Thread	Thread Length	Overall Length	Wheel Diameter	Journal Length	Hex Thickness	Vee Height	Hex Size	End Hex Size
		A	B ¹	C	D	E	F	G	H	J	K ²	L	M ³
0	Concentric	---	---	---	M6 x 1.0	.300 [7.62]	.667 [16.95]	Ø0.584 [Ø14.83]	.300 [7.62]	.117 [2.97]	.242 [6.15]	.433 [11.0]	---
	Eccentric	.032 [.81]	Ø.219 [Ø5.56]	.085 [2.16]	M5 x 0.8	.215 [5.46]							
1	Concentric	---	---	---	M8 x 1.25	.319 [8.10]	.761 [19.33]	Ø.771 [Ø19.58]	.319 [8.10]	.132 [3.36]	.287 [7.30]	.472 [12.0]	---
	Eccentric	.033 [.84]	Ø.248 [Ø6.30]	.085 [2.16]	M6 x 1.0	.234 [5.94]							
2	Concentric	---	---	---	M10 x 1.5	.448 [11.38]	1.046 [26.57]	Ø1.210 [Ø30.73]	.448 [11.38]	.160 [4.07]	.379 [9.63]	.551 [14.0]	.158 [4.0]
	Eccentric	.038 [.97]	Ø.375 [Ø9.53]	.109 [2.78]	M8 x 1.25	.338 [8.59]							

Notes:

1. Tolerances for Eccentric Shoulder Diameter (B) are: +.002/-0.000 [+0.05/-0.00]
2. Tolerance for Vee Height (K) are: +/-0.004 [+/-0.10]
3. End hex provides easy external means for adjustment.
4. See the Technical Data catalog for recommended mounting geometry.

Part Number Scheme:

PREFIX	ADJUSTABILITY	SIZE	WHEEL VERSION
SWI	C	0	P
	E	1	
		2	

Part Number Example:

SWIE1P = Studded Wheel Integrated, Eccentric, Size 1, Polymer

BUSHINGS | IMPERIAL

Mounting for Original Guide Wheels

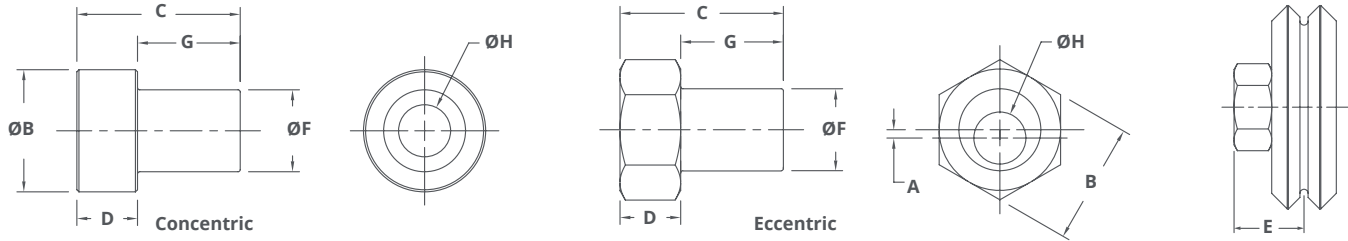

Dimensions														
SIZE	HEAD PROFILE	ADJUSTABILITY	Eccentric Offset	Head Size	Overall Height	Head Thickness	Mounting Surface to Wheel Vee	Wheel Mounting Diameter	Wheel Mounting Length	Mounting Hole Diameter	Recommended Mounting Hardware			
			A	B	C	D'	E	F	G	H	Screws			
1	Standard	Concentric	---	Ø.440 [Ø11.18]	.550 [13.97]	.250 [6.35]	.405 [10.29]	Ø.1871 [Ø4.75]	.300 [7.62]	Ø.1406 [Ø4.75]	#6			
		Eccentric	.012 [.30]	.438 [11.13]	.380 [9.65]	.080 [2.03]	.235 [5.97]					Ø.1570 [Ø3.99]	M4	
	Low	Concentric	---	Ø.440 [Ø11.18]										
		Eccentric	.007 [.18]	.438 [11.13]										
2	Standard	Concentric	---	Ø.560 [Ø14.22]				.706 [17.93]	.281 [7.14]	.500 [12.70]	Ø.3746 [Ø9.51]	.425 [10.80]	Ø.250 [Ø6.35]	1/4
		Eccentric	.024 [.61]	.562 [14.27]										
	Low	Concentric	---	Ø.560 [Ø14.22]	.525 [13.34]	.100 [2.54]	.319 [8.10]							
		Eccentric	.024 [.61]	.562 [14.27]										
3	Standard	Concentric	---	Ø.750 [Ø19.05]				.990 [25.15]	.375 [9.53]	.688 [17.48]	Ø.4720 [Ø11.99]	.615 [15.62]	Ø.3125 [Ø7.94]	5/16
		Eccentric	.042 [1.07]	.750 [19.05]										
	Low	Concentric	---	Ø.750 [Ø19.05]	.740 [18.80]	.125 [3.18]	.438 [11.13]							
		Eccentric	.042 [1.07]	.750 [19.05]										
4	Standard	Concentric	---	Ø.880 [Ø22.35]				1.177 [29.90]	.437 [11.10]	.812 [20.62]	Ø.5902 [Ø14.99]	.740 [18.80]	Ø.3750 [Ø9.53]	3/8
		Eccentric	.060 [1.52]	.875 [22.23]										
	Low	Concentric	---	Ø.880 [Ø22.35]	.865 [21.97]	.125 [3.18]	.500 [12.70]							
		Eccentric	.060 [1.52]	.875 [22.23]										
4XL	Standard	Concentric	---	Ø1.250 [Ø31.75]				1.555 [39.50]	.565 [14.35]	1.065 [27.05]	Ø.8657 [Ø21.99]	.990 [25.15]	Ø.5625 [Ø14.29]	9/16
		Eccentric	.060 [1.52]	1.250 [31.75]										
	Low	Concentric	---	Ø1.250 [Ø31.75]	1.178 [29.92]	.188 [4.78]	.688 [17.48]							
		Eccentric	.060 [1.52]	1.250 [31.75]										

Notes:

- Tolerance for Head Thickness (D) is: +/- .001 [+/- .03]
- Bushing material is AISI 303 stainless steel.
- See the Technical Data catalog for recommended mounting geometry.

Part Number Scheme for Standard Head Profile

PREFIX	SIZE	SUFFIX	ADJUSTABILITY
B	1	SS	Blank (Concentric)
	2		X (Eccentric)
	3		
	4		
	4XL		

Part Number Example:

BX3SS = Imperial Bushing, Standard Head Profile, Eccentric, Size 3, Stainless Steel

Part Number Scheme for Low Head Profile

SIZE	SERIES	ADJUSTABILITY
1	PWB	C (Concentric)
2		X (Eccentric)
3		
4		
4XL		

Part Number Example:

4XLPWBX = Size 4XL, Imperial Bushing, Low Head Profile, Eccentric

BUSHINGS | METRIC

Mounting for Original Guide Wheels

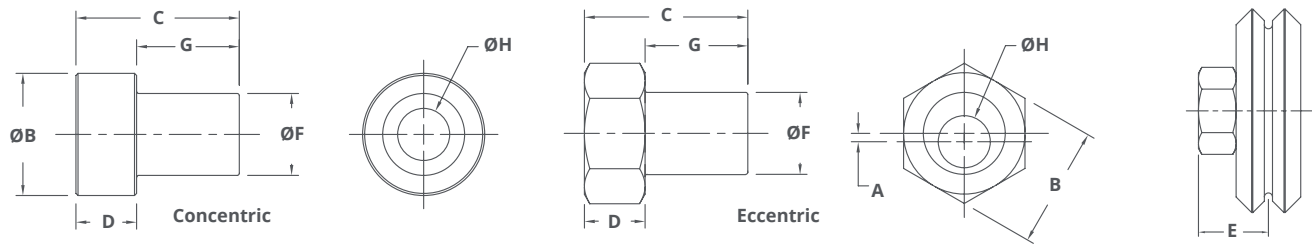

Dimensions											
SIZE	HEAD PROFILE	ADJUSTABILITY	ECENTRIC OFFSET	HEAD SIZE	OVERALL HEIGHT	HEAD THICKNESS	MOUNTING SURFACE TO WHEEL VEE	WHEEL MOUNTING DIAMETER	WHEEL MOUNTING LENGTH	MOUNTING HOLE	RECOMMENDED MOUNTING HARDWARE
			A	B	C	D'	E	F	G	H	SCREWS
1	Standard	Concentric	---	Ø.440 [Ø11.18]	.545 [13.84]	.245 [6.22]	.400 [10.16]	Ø.1871 [Ø4.75]	.300 [7.62]	Ø.1570 [Ø3.99]	M4
		Eccentric	.010 [.30]	.472 [11.99]							
	Low	Concentric	---	Ø.440 [Ø11.18]	.383 [9.73]	.083 [2.11]	.238 [6.05]				
		Eccentric	.007 [.18]	.472 [11.99]							
2	Standard	Concentric	---	Ø.560 [Ø14.22]	.687 [17.45]	.262 [6.65]	.48 [12.22]	Ø.3746 [Ø9.51]	.425 [10.80]	Ø.2362 [Ø6.00]	M6
		Eccentric	.024 [.61]	.551 [14.00]							
	Low	Concentric	---	Ø.560 [Ø14.22]	.529 [13.44]	.104 [2.64]	.323 [8.20]				
		Eccentric	.024 [.61]	.551 [14.00]							
3	Standard	Concentric	---	Ø.750 [Ø19.05]	.988 [25.10]	.373 [9.47]	.686 [17.42]	Ø.4720 [Ø11.99]	.615 [15.62]	Ø.3150 [Ø8.00]	M8
		Eccentric	.042 [1.07]	.748 [19.00]							
	Low	Concentric	---	Ø.750 [Ø19.05]	.752 [19.10]	.137 [3.48]	.450 [11.43]				
		Eccentric	.042 [1.07]	.748 [19.00]							
4	Standard	Concentric	---	Ø.880 [Ø22.35]	1.177 [29.90]	.437 [11.10]	.812 [20.62]	Ø.5902 [Ø14.99]	.740 [18.80]	Ø.3937 [Ø10.00]	M10
		Eccentric	.060 [1.52]	.866 [22.00]							
	Low	Concentric	---	Ø.880 [Ø22.35]	.862 [21.89]	.122 [3.10]	.497 [12.62]				
		Eccentric	.060 [1.52]	.866 [22.00]							
4XL	Standard	Concentric	---	Ø1.250 [Ø31.75]	1.555 [39.50]	.565 [14.35]	1.065 [27.05]	Ø.8657 [Ø21.99]	.990 [25.15]	Ø.5512 [Ø14.00]	M14
		Eccentric	.060 [1.52]	1.18 [30.00]							
	Low	Concentric	---	1.181 [Ø30.00]	1.191 [30.25]	.201 [5.11]	.701 [17.81]				
		Eccentric	.060 [1.52]	1.181 [30.33]							

Notes:

1. Tolerance for Head Thickness (D) is: +/--.001 [+/--.03]
2. Bushing material is AISI 303 stainless steel.
3. See the Technical Data catalog for recommended mounting geometry.

Part Number Scheme for Standard Head Height:

PREFIX	SIZE	SUFFIX	ADJUSTABILITY
MB	1	SS	Blank (Concentric)
	2		X (Eccentric)
	3		
	4		
	4XL		

Part Number Example:

MBX4SS = Metric Bushing, Standard Head Profile, Eccentric, Size 4, Stainless Steel

Part Number Scheme for Low Head Height:

PREFIX	SIZE	SERIES	ADJUSTABILITY
M	1	PWB	C (Concentric)
	2		X (Eccentric)
	3		
	4		
	4XL		

Part Number Example:

M2PWBC = Metric Bushing, Size 2, Low Head Profile, Concentric

JOURNALS

Mounting for Original Guide Wheels

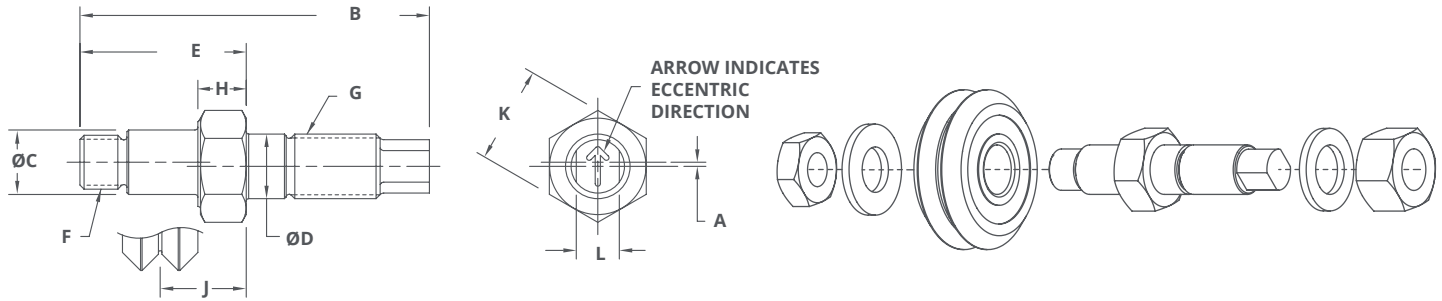

Dimensions

SIZE	ADJUSTABILITY	ECENTRIC OFFSET	OVERALL LENGTH	WHEEL MOUNTING DIAMETER	JOURNAL MOUNTING DIAMETER	JOURNAL LENGTH	WHEEL MOUNT THREAD	JOURNAL MOUNT THREAD	HEX THICKNESS	VEE HEIGHT	HEX SIZE	WRENCH FLATS	MOUNTING PLATE THICKNESS	
		A	B	C	D'	E	F	G	H	J	K	L	MIN.	MAX
0	Concentric	---	1.450 [36.83]	Ø.1571 [Ø3.99]	Ø.250 [Ø6.35]	.695 [17.65]	8-32	1/4-28	.250 [6.35]	.375 [9.53]	.375 [9.53]	.125 [3.18]	.125 [3.18]	.375 [9.53]
	Eccentric	.010 [.25]												
1	Concentric	---	1.540 [39.12]	Ø.1871 [Ø4.752]	Ø.250 [Ø6.35]	.785 [19.94]	10-32	1/4-28	.250 [6.35]	.405 [10.29]	.438 [11.11]	.125 [3.18]	.125 [3.18]	.375 [9.53]
	Eccentric	.012 [.30]												
2	Concentric	---	2.173 [55.19]	Ø.3746 [Ø9.515]	Ø.375 [Ø9.525]	1.109 [28.17]	5/16-24	3/8-24	.281 [7.14]	.500 [12.70]	.563 [14.29]	.250 [6.35]	.187 [4.75]	.500 [12.70]
	Eccentric	.024 [.61]												
3	Concentric	---	2.620 [66.55]	Ø.4720 [Ø11.989]	Ø.437 [Ø11.10]	1.375 [34.93]	7/16-20	7/16-20	.375 [9.53]	.688 [17.46]	.750 [19.05]	.250 [6.35]	.250 [6.35]	.625 [15.88]
	Eccentric	.042 [1.07]												
4	Concentric	---	3.068 [77.93]	Ø.5904 [Ø14.996]	Ø.500 [Ø12.70]	1.565 [39.75]	1/2-20	1/2-20	.437 [11.10]	.812 [20.62]	.875 [22.23]	.312 [7.92]	.375 [9.53]	.750 [19.05]
	Eccentric	.060 [1.52]												
4XL	Concentric	---	4.070 [103.38]	Ø.8657 [Ø21.989]	Ø.750 [Ø19.05]	2.045 [51.94]	3/4-16	3/4-16	.565 [14.35]	.940 [23.88]	1.250 [31.75]	.437 [11.10]	.750 [19.05]	1.125 [28.58]
	Eccentric	.060 [1.52]												

Notes:

1. Tolerance for Journal Mounting Diameter (D) are: +.000/-0.002 [+00/-0.05]
2. Journal assemblies are supplied with mounting nuts and washers, without guide wheel.
3. Flat washers are stainless steel.
4. Journal material is AISI 303 stainless steel.
5. Nuts are Nylon locking zinc plated carbon steel.
6. Engraved arrow is on the eccentric version only.

Part Number Scheme:

PREFIX	ADJUSTABILITY	SIZE	SUFFIX
MJ	C	0	A
	X	1	
		2	
		3	
		4	
		4XL	

Part Number Example:

MJX2A = Journal, Eccentric, Size 2, Assembly

TRACK

Single Edge

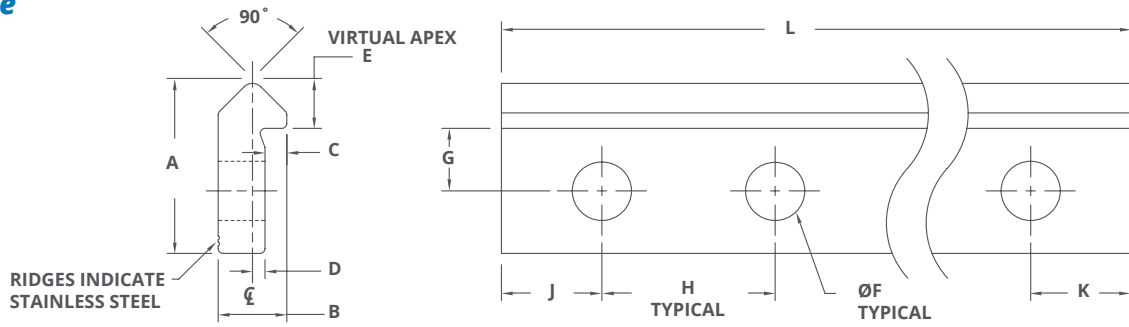

Dimensions

SIZE	OVERALL WIDTH	OVERALL HEIGHT	UNDERCUT DEPTH	UNDERCUT TO VEE	SHOULDER TO VEE APEX	HOLE DIAMETER	SHOULDER TO HOLE	HOLE SPACING	HOLE END SPACING 1	HOLE END SPACING 2	OVERALL LENGTH
	A	B	C	D	E	F	G ¹	H ²	J ³	K ³	L ⁴
1	.437 [11.10]	.187 [4.75]	.062 [1.57]	.031 [.79]	.125 [3.18]	Ø.156 [Ø3.96]	.156 [3.96]	2.000 [50.8]	.250 [6.35]	.250 [6.35]	Standard Versions or User Specified
2	.625 [15.88]	.250 [6.35]	.094 [2.39]	.031 [.79]	.187 [4.75]	Ø.203 [Ø5.16]	.219 [5.56]	3.000 [76.2]	.315 [8.00]	.315 [8.00]	
3	.875 [22.23]	.343 [8.71]	.109 [2.77]	.062 [1.57]	.250 [6.35]	Ø.281 [Ø7.14]	.313 [7.95]	3.000 [76.2]	.375 [9.53]	.375 [9.53]	
4	1.062 [26.97]	.437 [11.10]	.125 [3.18]	.093 [2.36]	.312 [7.92]	Ø.344 [Ø8.74]	.375 [9.53]	4.000 [101.6]	.500 [12.7]	.500 [12.7]	

Notes:

- Tolerance for Shoulder to Hole (G) is: +/- .005 [+/-0.13]
- Tolerance for Hole Spacing (H) are non-cumulative and is: +/- .005 [+/-0.13]
- Tolerance for Hole End Spacing 1 & 2 (J & K) are: +/- .005 [+/-0.13]
- Tolerances for Overall Length (L) are: +/- .015 [+/- .38] with holes, and +/- .063 [+/-1.60] when cut to length without holes.
- Carbon steel track material is AISI 1045, available soft at HRc 22-25, or induction hardened 0.01" deep to HRc 53 minimum.
- Stainless steel track material is AISI 420, available soft at HRc 20-22, or induction hardened 0.01" deep to HRc 40 minimum. Call to discuss other material options.
- Track finish is polished and oiled for corrosion resistance.
- Maximum single piece track lengths are 20 feet hardened, or 22 feet soft.

Part Number Scheme:

PREFIX	HARDENED	SIZE	MATERIAL	LENGTH IN INCHES	NUMBER OF HOLES
T	Blank	1	Blank	See Chart	See Chart
	S	2	SS		
		3			
		4			

Part Number Example:

TS2SS606321 = Track, Soft, Stainless Steel, 60.63 inches long, 21 holes
 *Track available by the foot uses a different Part Number Scheme: T_#_##. The underscore is for hard/soft, # for size, and ## for length in feet.

Dimensions

STANDARD LENGTHS AND HOLES											
SIZE	LENGTH	# OF HOLES	SIZE	LENGTH	# OF HOLES	SIZE	LENGTH	# OF HOLES	SIZE	LENGTH	# OF HOLES
1	12.50 [317.5]	7	2	12.63 [320.8]	5	3	12.75 [323.9]	5	4	13.00 [330.2]	4
	24.50 [622.3]	13		24.63 [625.6]	9		24.75 [628.7]	9		25.00 [635.0]	7
	36.50 [927.1]	19		36.63 [930.4]	13		36.75 [933.5]	13		37.00 [939.8]	10
	48.50 [1231.9]	25		48.63 [1235.2]	17		48.75 [1238.3]	17		49.00 [1244.6]	13
	60.50 [1536.7]	31		60.63 [1540.0]	21		60.75 [1543.1]	21		61.00 [1549.4]	16
	72.50 [1841.5]	37		72.63 [1844.8]	25		72.75 [1847.9]	25		73.00 [1854.2]	19

WHEEL COVERS

SWA Series Studded Wheels & Bushings

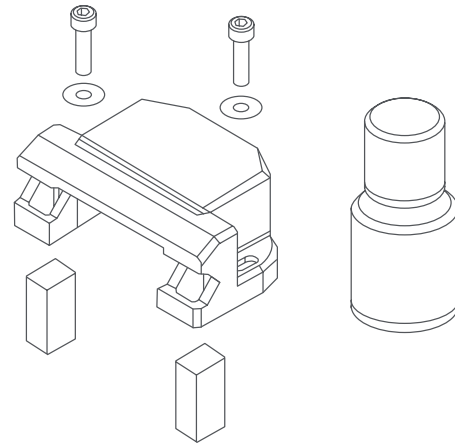
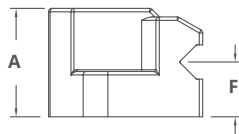
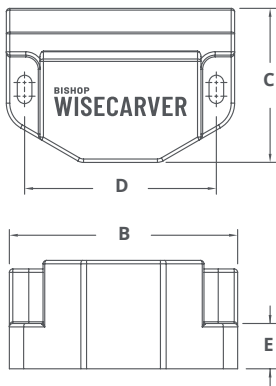

Dimensions

SIZE	MOUNTING COMPATIBILITY	OVERALL HEIGHT	OVERALL LENGTH	OVERALL WIDTH	SLOT SPAN	BASE THICKNESS	MOUNTING SURFACE TO TRACK VEE	MOUNTING HARDWARE	
		A	B	C	D	E	F	SCREWS	WASHERS
1	Standard Profile Bushings	.710 [18.03]	1.400 [35.56]	.900 [22.86]	1.200 [30.48]	.317 [8.05]	.317 [8.05]	M2 x 0.4 x 12 mm	M2
	Low Profile Bushings SWA Series	.553 [14.05]	1.400 [35.56]	.900 [22.86]	1.200 [30.48]	.160 [4.06]	.247 [6.27]	M2 x 0.4 x 8 mm	
2	Standard Profile Bushings	.950 [24.13]	2.000 [50.80]	1.350 [34.29]	1.680 [42.67]	.397 [10.08]	.480 [12.19]	M3 x 0.5 x 16 mm	M3
	Low Profile Bushings SWA Series	.792 [20.12]	2.000 [50.80]	1.350 [34.29]	1.680 [42.67]	.239 [6.07]	.322 [8.18]	M3 x 0.5 x 12 mm	
3	Standard Profile Bushings	1.340 [34.04]	2.670 [67.82]	1.975 [50.17]	2.340 [59.44]	.604 [15.34]	.690 [17.53]	M3 x 0.5 x 20 mm	M3
	Low Profile Bushings SWA Series	1.104 [28.04]	2.670 [67.82]	1.975 [50.17]	2.340 [59.44]	.368 [9.35]	.454 [11.53]	M3 x 0.5 x 19 mm	
4	Standard Profile Bushings	1.580 [40.13]	3.500 [88.90]	2.500 [63.50]	3.070 [77.98]	.760 [19.30]	.813 [20.65]	M4 x 0.7 x 25 mm	M4
	Low Profile Bushings SWA Series	1.265 [32.13]	3.500 [88.90]	2.500 [63.50]	3.070 [77.98]	.445 [11.30]	.498 [12.65]	M4 x 0.7 x 20 mm	

Notes:

1. Wheel cover material is black ABS.
2. Lubricator felt material is white wool.
3. Lubricant is light weight synthetic oil.
4. Mounting hardware is stainless steel.

Part Number Scheme:

PREFIX	SIZE	VERSION	SUFFIX
WC	1	Blank	A
	2	LP	
	3		
	4		

Part Number Example:

WC4LPA = Wheel Cover, Size 4, Low Profile, Assembly

WHEEL COVERS

SWS/SWI Series Studed Wheels & Bushings

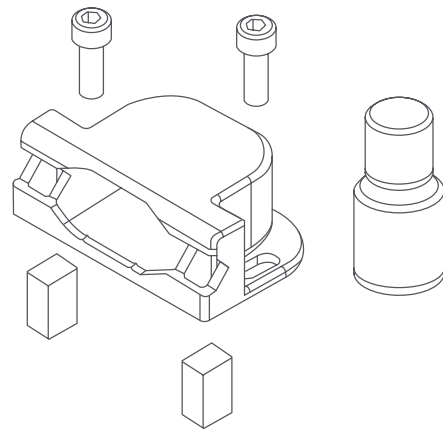
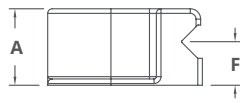
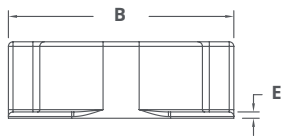
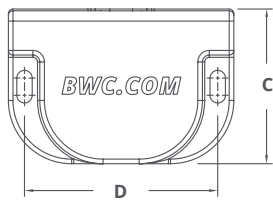

Dimensions

SIZE	MOUNTING COMPATIBILITY	OVERALL HEIGHT	OVERALL LENGTH	OVERALL WIDTH	SLOT SPAN	BASE THICKNESS	MOUNTING SURFACE TO TRACK VEE	MOUNTING HARDWARE
		A	B	C	D	E	F	SCREWS
1	SWS/SWI Series	.525 [13.34]	1.496 [38.00]	.960 [24.38]	1.250 [31.75]	.055 [1.40]	.287 [7.29]	M3 x 0.5 x 10 mm
2	SWS/SWI Series	.665 [16.89]	1.960 [49.78]	1.345 [34.16]	1.680 [42.67]	.055 [1.40]	.379 [9.63]	M3 x 0.5 x 10 mm
3	SWS/SWI Series	.915 [23.24]	2.650 [67.31]	1.970 [50.04]	2.340 [59.44]	.055 [1.40]	.536 [16.61]	M3 x 0.5 x 10 mm
4	SWS/SWI Series	1.155 [29.34]	3.460 [87.88]	2.550 [64.77]	3.070 [77.80]	.055 [1.40]	.644 [16.36]	M4 x 0.7 x 12 mm

Notes:

1. Wheel cover material is black Nylon.
2. Lubricator felt material is white wool.
3. Lubricant is light weight synthetic oil.
4. Mounting hardware is stainless steel.

Part Number Scheme:

PREFIX	SIZE	VERSION	SUFFIX
WC	1	SWI	A
	2		
	3		
	4		

Part Number Example:

WC1SWIA = Wheel Cover, Size 1, Studed Wheels Integrated, Assembly

TRACK LUBRICATORS

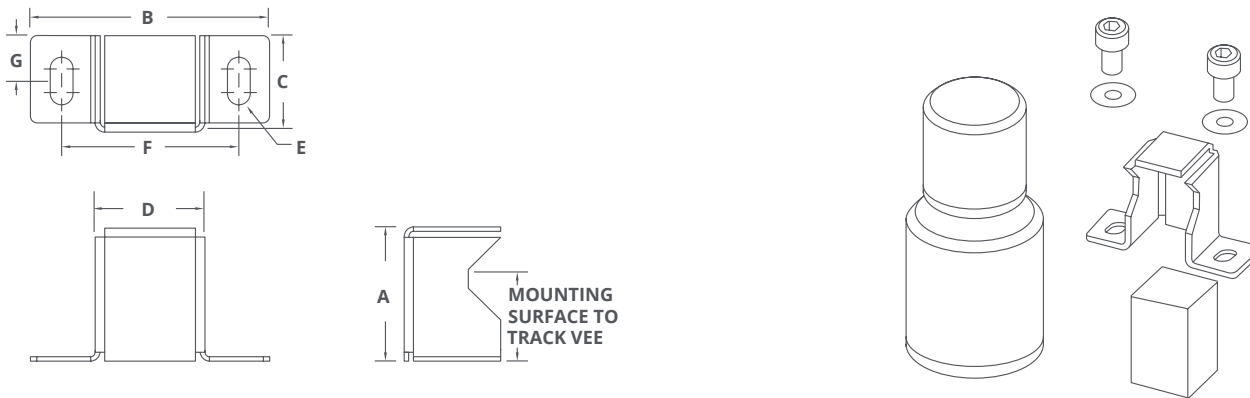

Dimensions

SIZE	MOUNTING COMPATIBILITY	OVERALL HEIGHT	OVERALL LENGTH	OVERALL WIDTH	HOLDER LENGTH	SLOT DIAMETER	SLOT SPAN	SLOT CENTER	MOUNTING SURFACE TO TRACK VEE		MOUNTING HARDWARE		
		A	B	C	D	E	F	G	MIN.	MAX.	SIZE	SCREWS	WASHERS
0	Studded Wheels	.360 [9.14]	.670 [17.02]	.300 [7.62]	.230 [5.84]	Ø.094 [Ø2.39]	.472 [11.99]	.115 [2.92]	.205 [5.21]	.242 [6.15]	0	M2 x 0.4 x 4 mm	M2
1 & 2	Bushings Standard Journals	.690 [17.53]	1.102 [27.99]	.450 [11.43]	.472 [11.99]	Ø.120 [Ø3.05]	.787 [19.99]	.180 [4.57]	.370 [9.40]	.500 [12.70]	1	M2 x 0.4 x 5 mm	M2
	Bushings Low SWA Series	.533 [13.54]	1.102 [27.99]	.450 [11.43]	.472 [11.99]	Ø.120 [Ø3.05]	.787 [19.99]	.180 [4.57]	.213 [5.41]	.343 [8.71]			
	SWS Series	.580 [14.73]	1.126 [28.60]	.450 [11.43]	.472 [11.99]	Ø.120 [Ø3.05]	.799 [20.29]	.180 [4.57]	.270 [6.86]	.390 [9.91]	2	M3 x 0.5 x 6 mm	M3
3 & 4	Bushings Standard Journals	1.200 [30.48]	1.839 [46.71]	.740 [18.80]	.839 [21.31]	Ø.170 [Ø4.32]	1.339 [34.01]	.290 [7.37]	.638 [16.21]	.867 [22.02]	3	M3 x 0.5 x 6 mm	M3
	Bushings Low SWA Series	.840 [21.34]	1.839 [46.71]	.740 [18.80]	.839 [21.31]	Ø.170 [Ø4.32]	1.339 [34.01]	.290 [7.37]	.450 [11.43]	.520 [13.21]			
	SWS Series	1.014 [25.76]	1.839 [46.71]	.740 [18.80]	.839 [21.31]	Ø.170 [Ø4.32]	1.339 [34.01]	.290 [7.37]	.513 [13.03]	.681 [17.30]	4	M4 x 0.7 x 8 mm	M3

Notes:

1. Felt holder material is AISI 300 stainless steel.
2. Lubricator felt material is white wool.
3. Lubricant is light weight synthetic oil.
4. Mounting hardware is stainless steel.

Part Number Scheme:

PREFIX	SIZE	VERSION	SUFFIX
TL	1	Blank	A
	2	LP	
	3	BWP	
	4		

Part Number Example:

TL1LPA = Track Lubricator, Size 1, Low Profile, Assembly
 *Size 0 uses a different Part Number Scheme: MVOTLA.

MINVEE® PRODUCT OVERVIEW

MinVee® linear slide systems from Bishop-Wisecarver Corporation are miniature guides consisting of a compact 1.75" wide by 2.00" long wheel plate with AISI 52100 carbon steel or polymer wheels and double vee-edge guide tracks.

When used with available 6063-T6 aluminum track support extrusion, assembled height is 0.788". **MinVee®** double edge track is available in AISI 1045 carbon steel in six standard lengths up to 36.5" with mounting holes predrilled. Axial working capacities are 121.4 lbf for steel wheels and 15 lbf for polymer wheel versions.

MinVee® is ideal for use in semiconductor, laboratory, and medical applications with compact space requirements.

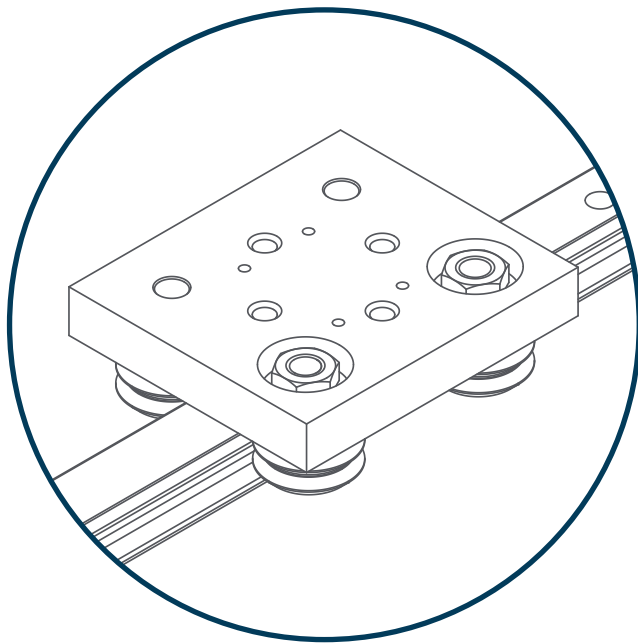

Standard MinVee® Assembly

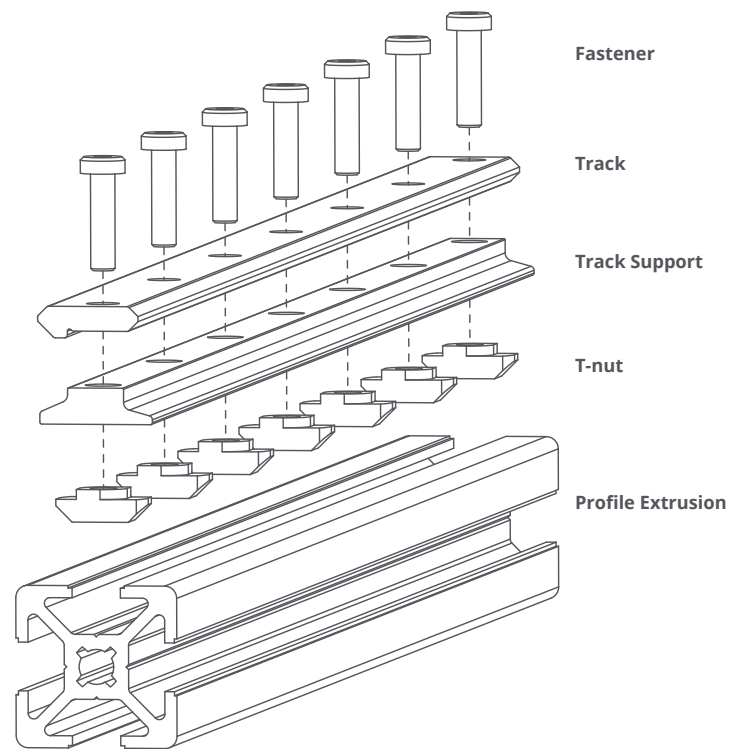

MinVee® Mounting Suggestion

Wheel Plates

- 6061-T6 clear anodized aluminum wheel plate with stainless steel lubricator housing and felt lubrication pads.
- Two (2) concentric and two (2) eccentric DualVee® studed wheels.
- Carbon steel, stainless steel, or polymer over-molded stainless steel bearings

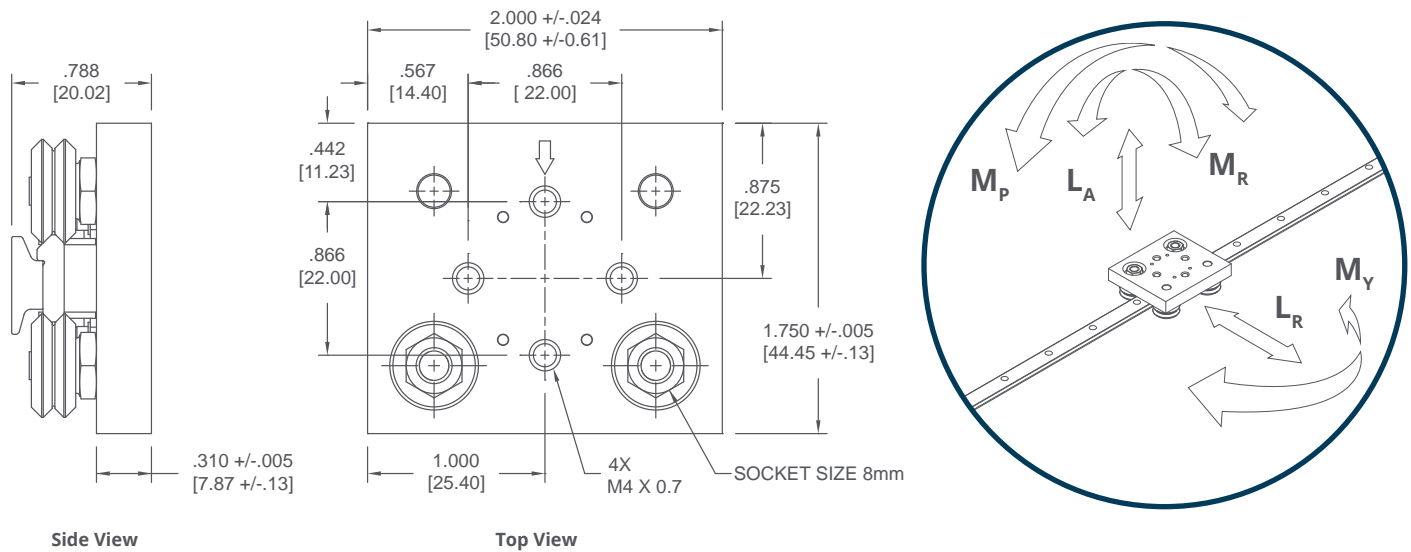

Dimensions

STOCK CODE	WHEEL VERSION	TEMPERATURE RANGE	MAXIMUM SPEED	MAXIMUM ACCELERATION	PITCH MOMENT (M_P)	YAW MOMENT (M_Y)	ROLL MOMENT (M_R)	WORKING AXIAL LOAD CAPACITY (L_A)	WORKING RADIAL LOAD CAPACITY (L_R)	WEIGHT IN GRAMS (g)
MV0WPAP	Polymer Overmolded AISI 440C Stainless Steel, Shielded	-4°F to 248°F [-20°C to 120°C]	1m/s	3 g [29 m/s ²]	1.4 Nm [12.4 lbf-in]	4.5 Nm [39.8 lbf-in]	1 Nm [8.8 lbf-in]	66.7 N [15 lbf]	65 N [14.6 lbf]	72
MV0WPA	AISI 52100 Carbon Steel, Shielded	-31°F to 248°F [-35°C to 120°C]	5m/s	5g [49 m/s ²]	7.9 Nm [69.9 lbf-in]	8.6 Nm [76.1 lbf-in]	6.2 Nm [54.9 lbf-in]	540 N [121.4 lbf]	490 N [110.2 lbf]	84
MV0WPAX	AISI 52100 Carbon Steel, Sealed	-22°F to 212°F [-30°C to 100°C]								
MV0WPA-SS227	AISI 440C Stainless Steel, High Temperature, Shielded	-22°F to 500°F [-30°C to 260°C]								

Wheel plate assemblies are made from clear anodized 6061-T6 aluminum and include stainless steel lubricator housings with felt track wipers
Working load capacities are based on 100 km service life (62.1 miles at 23°C or 73°F and 50% humidity)

Double Edge

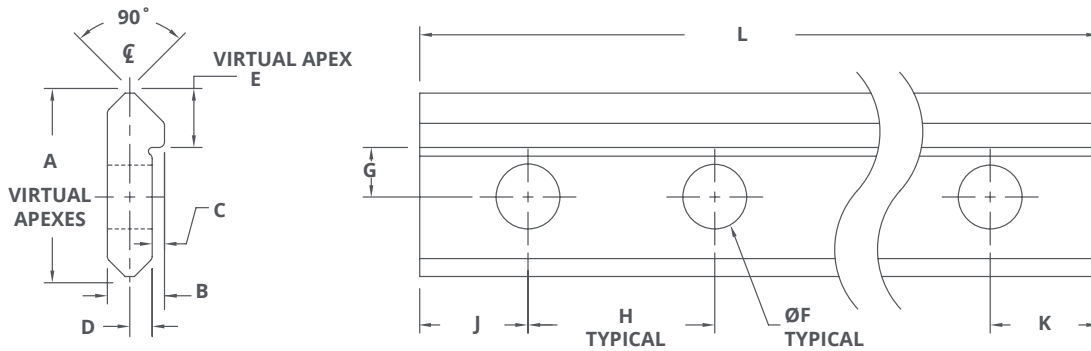

Dimensions

SIZE	OVERALL WIDTH	OVERALL HEIGHT	UNDERCUT DEPTH	UNDERCUT TO VEE	SHOULDER TO VEE APEX	HOLE DIAMETER	SHOULDER TO HOLE	HOLE SPACING	HOLE END SPACING 1	HOLE END SPACING 2	OVERALL LENGTH
	A	B	C	D	E	F	G ¹	H ²	J ³	K ³	L ⁴
0	.516 [13.11]	.153 [3.89]	.033 [.84]	.060 [1.52]	.158 [4.01]	Ø.156 [Ø3.96]	.138 [3.50]	2.000 [50.8]	.250 [6.35]	.250 [6.35]	Standard Versions or User Specified

STANDARD LENGTHS AND HOLES

SIZE	LENGTH	# OF HOLES
0	6.50 [165.1]	4
	12.50 [317.5]	7
	18.50 [469.9]	10
	24.50 [622.3]	13
	30.50 [774.7]	16
	36.50 [927.1]	19

Notes:

1. Tolerance for Shoulder to Hole (G) is: +/-0.005 [+/-0.13]
2. Tolerance for Hole Spacing (H) are non-cumulative and is: +/-0.005 [+/-0.13]
3. Tolerance for Hole End Spacing 1 & 2 (J & K) are: +/-0.005 [+/-0.13]
4. Tolerances for Overall Length (L) are: +/-0.015 [+/-0.38] with holes, and +/-0.063 [+/-1.60] when cut to length without holes.
5. Track material is AISI 1045 carbon steel, available soft at HRc 22-25, or induction hardened 0.01" deep to HRc 53 minimum.
6. Track finish is polished and oiled for corrosion resistance.
7. Maximum single piece track lengths are 20 feet hardened, or 22 feet soft.

Part Number Scheme:

PREFIX	HARDENED	SIZE	VERSION	LENGTH IN INCHES	NUMBER OF HOLES
TD	Blank	0	-	See Chart	See Chart
	S				

Part Number Example:

TDS0-245013 = Track Double Edge, Soft, Size 0, 25.50 inches long, 13 holes
 *Track available by the foot uses a different Part Number Scheme: TD_0-##.
 The underscore is for hard/soft, and ## for length in feet.

MINVEE® TRACK SUPPORT

Double Edge

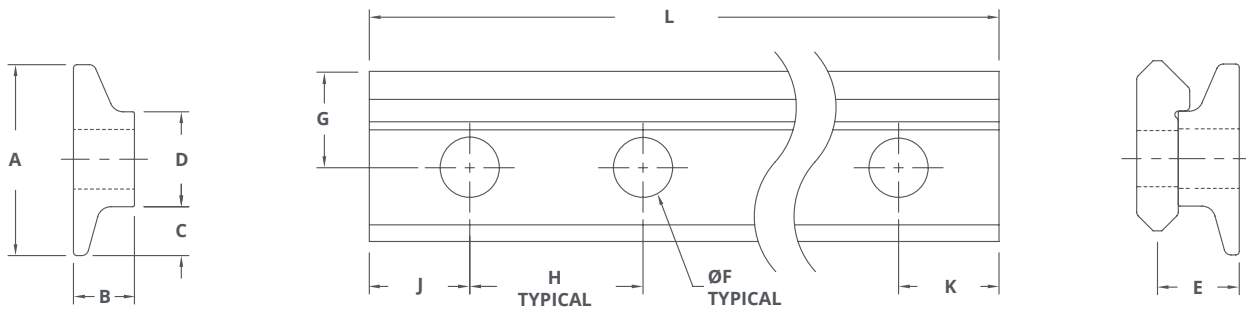

Dimensions

SIZE	OVERALL WIDTH	OVERALL HEIGHT	SURFACE TO EDGE	SURFACE WIDTH	VEE HEIGHT	HOLE DIAMETER	SHOULDER TO HOLE	HOLE SPACING	HOLE END SPACING 1	HOLE END SPACING 2	OVERALL LENGTH
	A	B	C	D	E	F	G ¹	H ²	J ³	K ³	L ⁴
0	.551 [14.00]	.176 [4.47]	.141 [3.58]	.274 [6.96]	.236 [5.99]	Ø.172 [Ø4.37]	.273 [6.93]	2.000 [50.8]	.250 [6.35]	.250 [6.35]	Standard Versions or User Specified

STANDARD LENGTHS AND HOLES

SIZE	LENGTH	# OF HOLES
0	6.50 [165.1]	4
	12.50 [317.5]	7
	18.50 [469.9]	10
	24.50 [622.3]	13
	30.50 [774.7]	16
	36.50 [927.1]	19

Notes:

1. Tolerance for Shoulder to Hole (G) is: +/--.005 [+/-0.13]
2. Tolerance for Hole Spacing (H) are non-cumulative and is: +/--.005 [+/-0.13]
3. Tolerance for Hole End Spacing 1 & 2 (J & K) are: +/--.005 [+/-0.13]
4. Tolerances for Overall Length (L) is: +/--.063 [+/-1.60]
5. Track support material is 6063-T6 aluminum with anodized finish.
6. Track support holes and cut to length ends are unfinished bare aluminum.
7. Maximum single piece track length is 10 feet.

Part Number Scheme:

PREFIX	SIZE	DESCRIPTION	DASH	LENGTH IN INCHES	DASH	NUMBER OF HOLES
MV	0	TS	-	See Chart	-	See Chart

Part Number Example:

MV0TS-1850-10 = Track Support, Size 0, 18.50 inches long, 10 holes

*Track support available by the foot uses a different Part Number Scheme: MV0TS-##. The ## is for length in feet.

MOTION SOLUTIONS FROM BISHOP-WISECARVER ARE LIMITED ONLY BY YOUR IMAGINATION

Components & Accessories

DualVee®
MadeWell®
GV3
SL2
PRT2
HDS2
HDRT
MCS
Motor Mounts
Gantry Brackets
Wrenches

Manual Linear Guide Systems

DualVee®
UtiliTrak®
MinVee®
GV3
Simple Select®
SL2
HDS2
MHD
HTS

Actuated Linear Guide Systems

LoPro®
XLA™
ECO60™
SlickStick™
SteadyRail™
HDLS
HDCS
PDU2
DAPDU2
SBD
PSD
SDM
DLS

Rotary Guide Systems

PRT2
DTS2
DTS
ALR
HDRT
1-Trak
GFX

Custom Solutions

Extruded Profile Guides
Custom Bearings
Custom Subassemblies
Engineering Services
Large Diameter Ring Guides and Track

BWC.COM

 **BISHOP
WISECARVER**
Expertly Designed, Delivered to Perform

Contact

Phone: (925) 439-8272
Email: Sales@bwc.com

2104 Martin Way
Pittsburg, CA 94565

