



PRODUCT BROCHURE



**KEEPING
YOUR FACILITY
DUST-FREE
CAN BE GOOD
FOR YOUR
EMPLOYEES
& YOUR
BOTTOM LINE.**

**Industrial dust
collectors not only
clear the air but
also improve:**

- Employee efficiency
- Increase employee retention
- Help ensure a safe working environment
- Reduce equipment maintenance costs

**Air quality
control goes
beyond just
having a clean
workspace.**



THE LEADER IN AIR

A.C.T. Dust Collectors offer the ultimate in air filtration.

Whether your application includes welding smoke, grinding dust, cutting table fume, shot blasting, sanding, thermal spray, coating, bulk powder handling or any process that generates dust, we have the solution.

Our high-performance systems are built with features to stand up to a rugged manufacturing environment.

The **downward airflow technology** maximizes airflow in the collector to assist dust separation. With capabilities up to 100,000 CFM and more, we have the system to maximize your air filtration.



FILTRATION

Each of our dust collectors is equipped with a **venturi-assisted reverse-pulse filter cleaning system** and a digital, solid-state pulse control panel. The controls utilize an on-board pressure switch allowing on-line, on-demand and down-time cleaning. A weatherproof housing protects the controls for a long, trouble-free life.

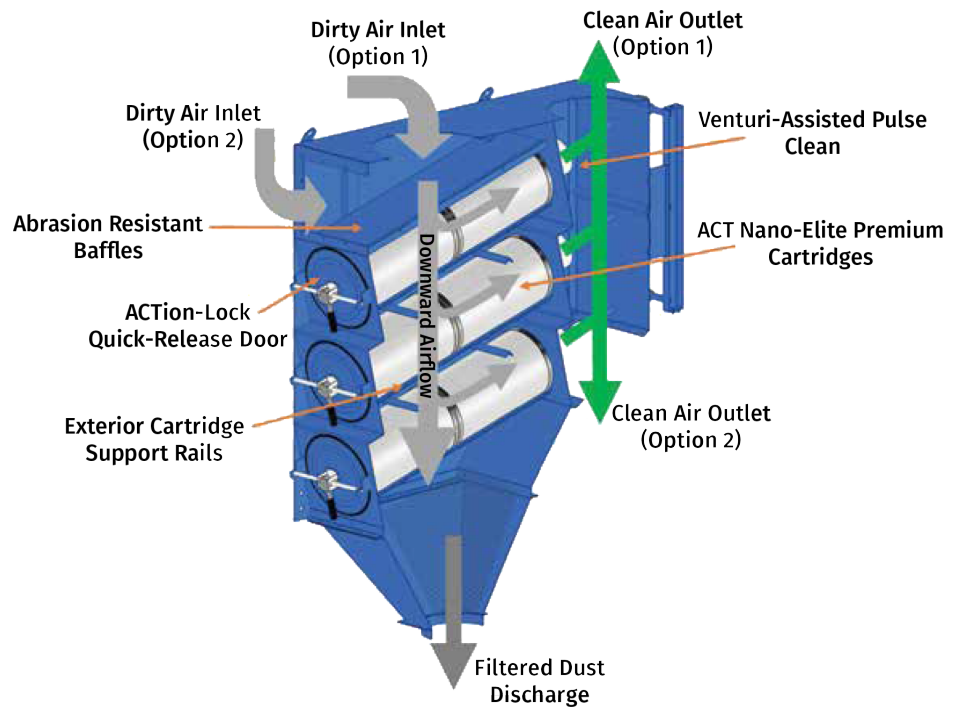

STANDARD FEATURES:

- Fully welded heavy construction main unit, constructed of 7 and 10 gauge carbon steel
- Designed, engineered and manufactured in the U.S.
- Exclusive ACTION-Lock Quick-Release filter door
- A.C.T. Nano-Elite Nano-Fiber High-Efficiency cartridge filters with 254 square feet of media each
- Venturi-assisted pulse clean system with premium Goyen® diaphragms and solenoids
- Exterior rail cartridge supports prevent pulse clean obstruction
- Downward airflow technology assists dust particle separation
- Integral lifting lugs
- Material discharge with sealing drum lid
- Digital, solid State Pulse Control with differential pressure switch for fully automatic cleaning
- Five-year materials and craftsmanship warranty

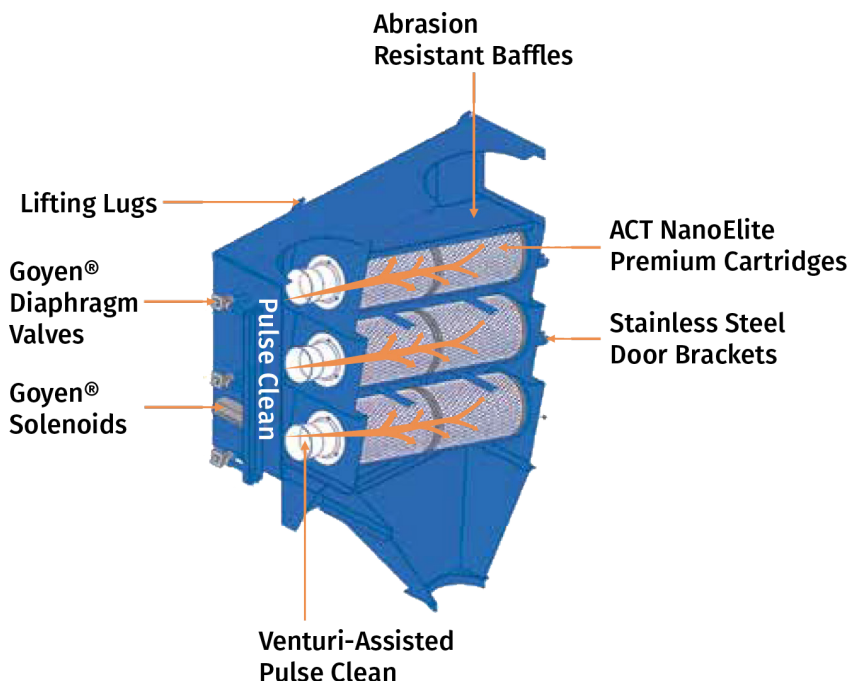

OPTIONAL FEATURES:

- Abrasive inlet plenum
- Complete line of motor/blowers
- Exhaust silencers and/or dampers
- Alternate filter media options
- Rotary airlocks
- Screw conveyors
- Explosion vents
- Solenoid heater kit
- Custom paint color or coatings
- Multi-module hoppers
- Steep-sloped hoppers
- Afterfilter housings
- Bag-in/bag-out design for hazardous dust
- Stainless steel construction

The most popular feature is our exclusive

ACTION-LOCK Quick-Release filter door.

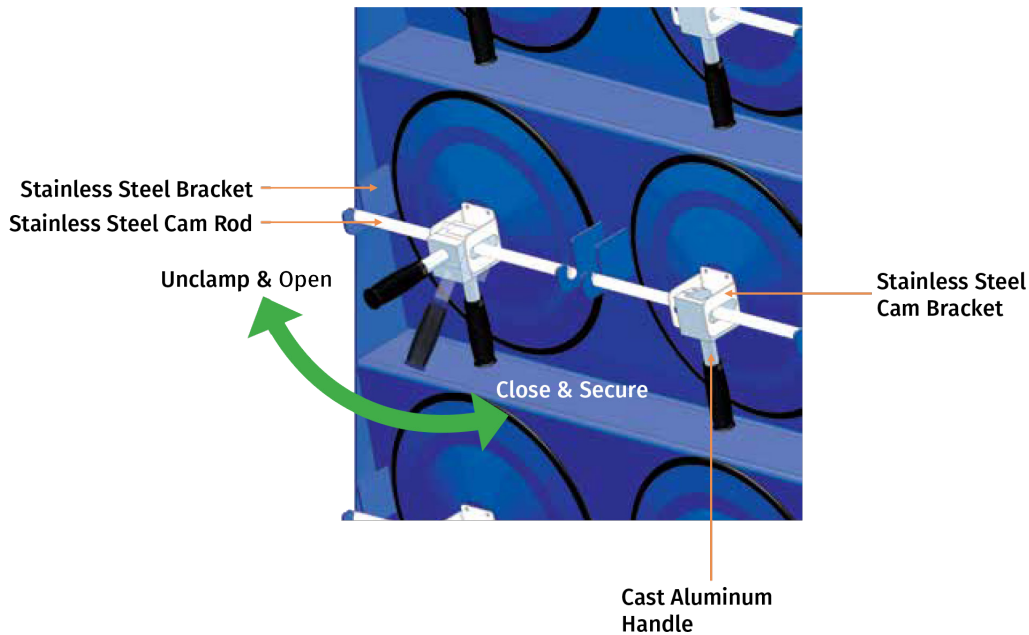

Only aluminum and stainless steel parts are used in the construction of the door cam and mounting brackets for maximum durability in any environment. Simply set the door in place and pull the handle down to lock the cam.

Lift the handle for quick release.



The simple and secure design is widely considered as the best in the industry. Using stainless steel brackets, cross rod and a cast aluminum handle, it will stand up to the toughest environments, both outside and inside your facility. There are no knobs to turn, no moving rails, no interior yokes or threads to catch, or holes to center up – just drop in the door and clamp down. Lift the handle and you're holding the best door the industry has ever seen.



The operation of our A.C.T. dust collectors is simple and uses proven technology.

The industry best **A.C.T. Nano-Elite high efficiency cartridge filters** remove 99.9% of the particulate from the air stream. They carry a **MERV 15** rating (best in the industry).

The cleaned air is then directed to the location of your choice, either returned to the facility or exhausted to the environment.



CARTRIDGE DIMENSIONS

EXPERIENCE, SERVICE & SUPPORT

- Technical expertise and factory support
- Ready-to-ship parts and filters
- Numerous successful installations worldwide

CUSTOM ENGINEERING

- Systems tailored to your specific needs
- Professional design & engineering experts
- Application assistance

Dimensions are not to be used for construction.

Certified drawings available upon request.

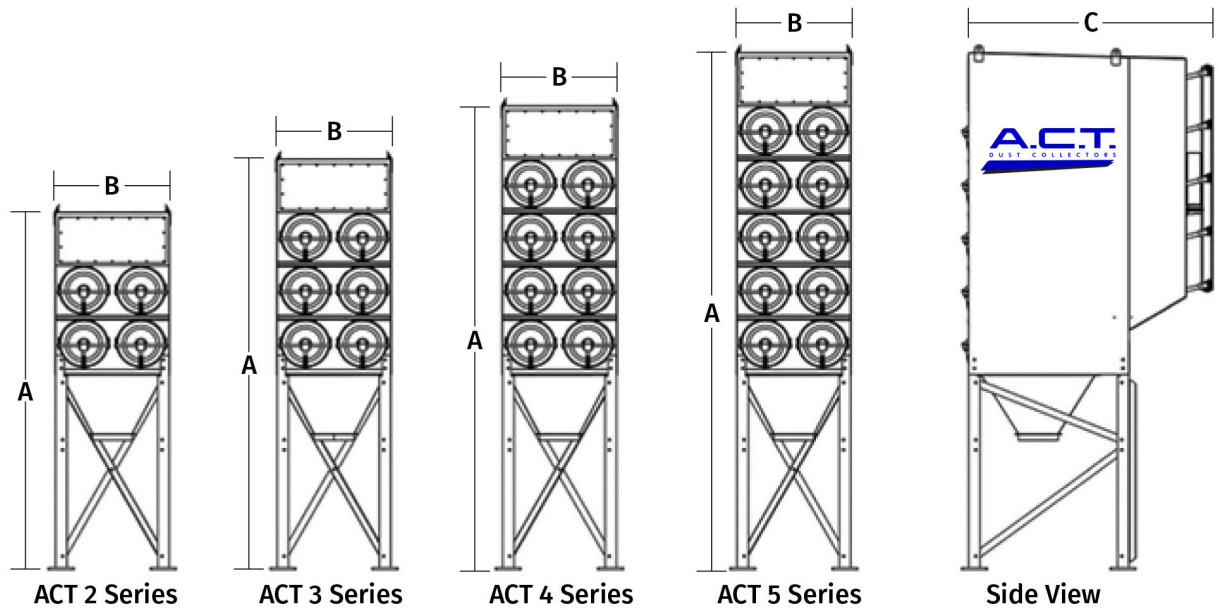

MODEL	HEIGHT (A)	WIDTH (B)	DEPTH (C)	# OF FILTERS	FILTER AREA
ACT 2-2	118"	49"	57"	2	508
ACT 2-4	127"	40"	61"	4	1,016
ACT 2-8	127"	40"	87"	8	2,032
ACT 2-12	127"	60"	87"	12	3,048
ACT 2-16	127"	80"	87"	16	4,064
ACT 2-24	127"	120"	87"	24	6,096
ACT 3-6	146"	40"	61"	6	1,524
ACT 3-12	146"	40"	87"	12	3,048
ACT 3-18	146"	60"	87"	18	4,572
ACT 3-24	146"	80"	87"	24	6,096
ACT 3-36	146"	120"	87"	36	9,144
ACT 3-48	146"	160"	87"	48	12,192
ACT 3-54	146"	180"	87"	54	13,716
ACT 3-72	146"	240"	87"	72	18,288
ACT 4-16	164"	40"	87"	16	4,064
ACT 4-32	164"	80"	87"	32	8,128
ACT 4-48	164"	120"	87"	48	12,192
ACT 4-64	164"	160"	87"	64	16,256
ACT 4-80	164"	200"	87"	80	20,320
ACT 4-96	164"	240"	87"	96	24,384
ACT 4-112	164"	280"	87"	112	28,448
ACT 4-128	164"	320"	87"	128	32,512
ACT 4-144	164"	360"	87"	144	36,576
ACT 5-20	178"	40"	87"	20	5,080
ACT 5-40	178"	80"	87"	40	10,160
ACT 5-60	178"	120"	87"	60	15,240
ACT 5-80	178"	160"	87"	80	20,320
ACT 5-100	178"	200"	87"	100	25,400

A.C.T. Dust Collectors

ACTion Booth is a multifunction dust collector designed to meet your workspace needs.

Hundreds of applications require general dust collection from a room, work area, enclosure or zone.

The heavily constructed ACTion Booth louvered door which is one of the largest in the industry, offers maximum dust collection at all work heights. The louvers are designed to assist fallout of heavy particulate while evenly distributing air across the vertical filters inside. The integrated blower and interior pulse clean diaphragm valves provide consistent, quiet and powerful performance.

With space at a premium, the ACTion Booth can be serviced from the front and top, allowing installation against walls on the back or sides.

ACTion Booth Power Module

5,400 CFM
4 Filters
7.5 HP





LASERPACK FEATURES

Dust particles, fumes and various oxides generated during the laser cutting process are dangerous to breathe. LaserPack dust collectors not only clear the air but also:

- Improve employee efficiency
- Increase employee retention
- Help ensure a safe working environment
- Reduce equipment maintenance costs

CUSTOM ENGINEERING

- Systems tailored to your specific needs
- Professional design & engineering experts
- Application assistance

Dimensions are not to be used for construction.

Certified drawings available upon request.

- A.C.T. Nano-Elite Nanofiber Cartridges
- Venturi-Assisted Pulse Cleaning System
- Control Box w/Digital Timer
- ACTION-LOCK Quick Release Doors
- Stainless Steel Door Components
- Side Inlet into Integrated Spark Trap
- Fully Welded Steel Construction
- Primed Interior
- Multi-Coat Paint Finish
- Dust Drawers
- 5-Year Warranty

Newest Model:



LaserPack 8
4,000 CFM
8 Filters
15 HP



DESIGNED FOR LA

A.C.T. Dust Collectors LaserPack is designed specifically for laser cutting industries and applications.

The LaserPack 4, LaserPack 6 and the Laserpack 8 are unique, heavy duty, and effective. They come as a plug-and-play package, complete with integrated cyclonic spark trap on the inlet of the dust collector.

The unit also features an integrated motor/blower that is surrounded with noise attenuation material for quiet operation. The controls are mounted on the side of the collector and prewired for easy, on site hook up.

The deluxe control system comes with every LaserPack, mounted to the system and pre-wired. This allows the LaserPack to integrate and start on-demand when your laser cutting system is turned on. The dust drawer base makes for easy handling and disposal of the collected dust.



LaserPack 4
2,000 CFM
4 Filters
5 HP

LaserPack 6
3,000 CFM
6 Filters
10 HP

LASER FUME EXTRACTION



BAGHOUSE FEATURES

EXPERIENCE, SERVICE & SUPPORT

- Technical expertise and factory support
- Ready-to-ship parts and filters
- Numerous successful installations worldwide

CUSTOM ENGINEERING

- Systems tailored to your specific needs
- Professional design & engineering experts
- Application assistance

Dimensions are not to be used for construction.

Certified drawings available upon request.

- Modular Design
- Venturi-Assisted Pulse Cleaning System
- Automatic Pulse Controls for both Online and DownTime Cleaning
- ACTION-Lock Exclusive Tool-Free Bag Replacement
- Clean Side, Top Access Snap Band Filter Bags
- Top Load Filter Change Out
- Hinged Filter Access Doors
- No Confined Space Filter Access
- OSHA Compliant Hand Rail and Caged Access Ladder
- Replaceable Bolt-On Deflection Baffle
- Pressure/Vacuum Rating $\pm 25''$ W.C.
- Premium Prime and Paint Exterior High Gloss Enamel
- 16 oz Polyester Filter Bags with Stainless Steel Snap Band

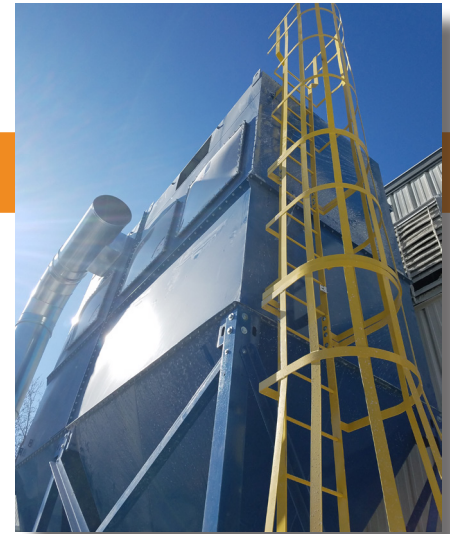

DEMANDING APPLIC

A.C.T. Dust Collectors

TLM Modular Baghouse is designed to meet the unique requirements of each application.

Starting with transportation, the dimensions of the TLM Baghouse are such that trucking can be done without oversize permits. Installation is simple and straightforward with the modular design and integral lifting lugs. Overall design is compact to minimize footprint and overall height to fit in the tightest space available.

Heavy-duty internally reinforced 10-gauge walls and robust structure meet industry demands. Utilizing computerized simulation software, the pulse-jet cleaning system operational design has been optimized for efficient cleaning and airflow. Hinged filter access doors and our exclusive tool-free bag replacement, allow for the quickest, easiest maintenance.

The TLM Baghouse brings you the culmination of many years of experience with quality and features unrivaled in the industry.



CATION

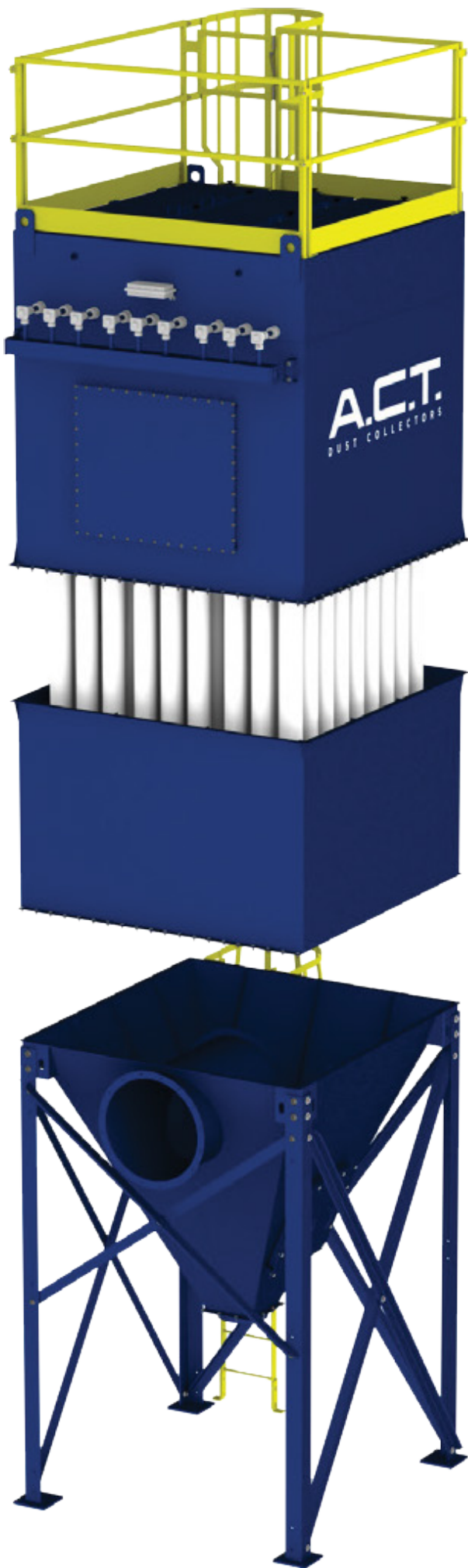

As the dust accumulates on the filters, an on-board pressure gauge monitors differential pressure between the clean side and the dirty side of the baghouse.

Once a set maximum differential pressure is reached, a solid state timer board activates the cleaning system. The timer board activates an electric solenoid, which opens the diaphragm valve. Compressed air from the manifold on the baghouse is released through the diaphragm valve into the blowpipe above the bag filters. The pressure from the pulse-jet removes the dust buildup by blowing it off outward from the inside of the filter. This all occurs while the system is online for continuous duty operation.

The TLM Baghouse features downtime cleaning as well, so the system performs a final pulse-clean cycle after shutdown to ensure maximum dust release and long filter life.

AVAILABLE BAGHOUSE OPTIONS

Rotary Airlocks with Hopper Mount Transitions

Screw Conveyors

Extended/Modified Steel Support Structure

Custom Filter Media Options

Motor/Blower for Specific Performance

Inlet or Outlet Dampers

Exhaust Silencer

Ductwork and Inlet/Outlet Manifolds

Afterfilter Plenums for HEPA or ASHRAE

NFPA 69 Compliant Backdraft Dampers/Explosion Isolation Valves

Explosion Venting

Motor Control Panels, (Soft Start, VFD's etc.)

Spark Detection System

High Speed Abort Gates

High Temperature Operation Components

Stainless Steel Construction

Custom Color Exterior Paint Finishes

Contact ACT for Additional Options.

The most popular feature is our exclusive

ACTION-LOCK Tool-Free Bag Replacement.

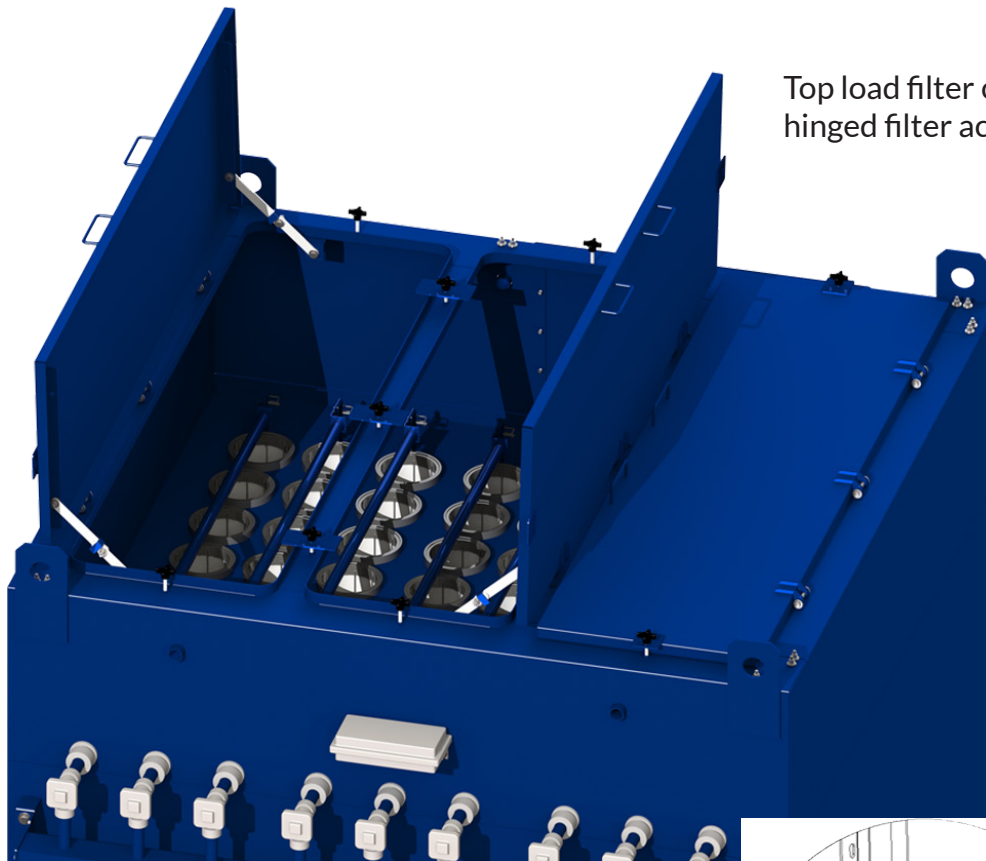

Top load filter change out and hinged filter access door

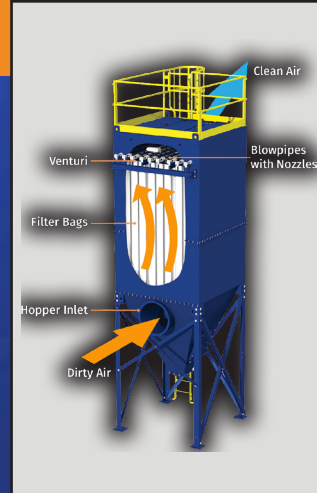

The TLM Baghouse operation is simple, proven, and efficient. Dust-laden air is drawn from the source through a duct system and into the hopper inlet.

Through air expansion and an internal deflection plate, the airstream velocity is reduced so large particles drop into the hopper below. The remaining dust particles are filtered through bag filters.

This ensures that only clean air passes into the clean air plenum, through the fan, and is either exhausted to the atmosphere or returned to the building.

1 Safety-lock, hinged filter access door

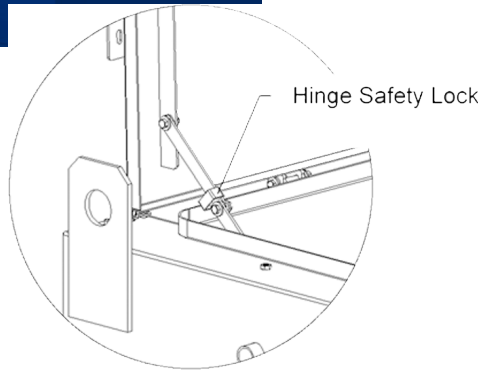

2 Swing-away, hinged pulse tube

3 Drop in cage and snap-band filter bag

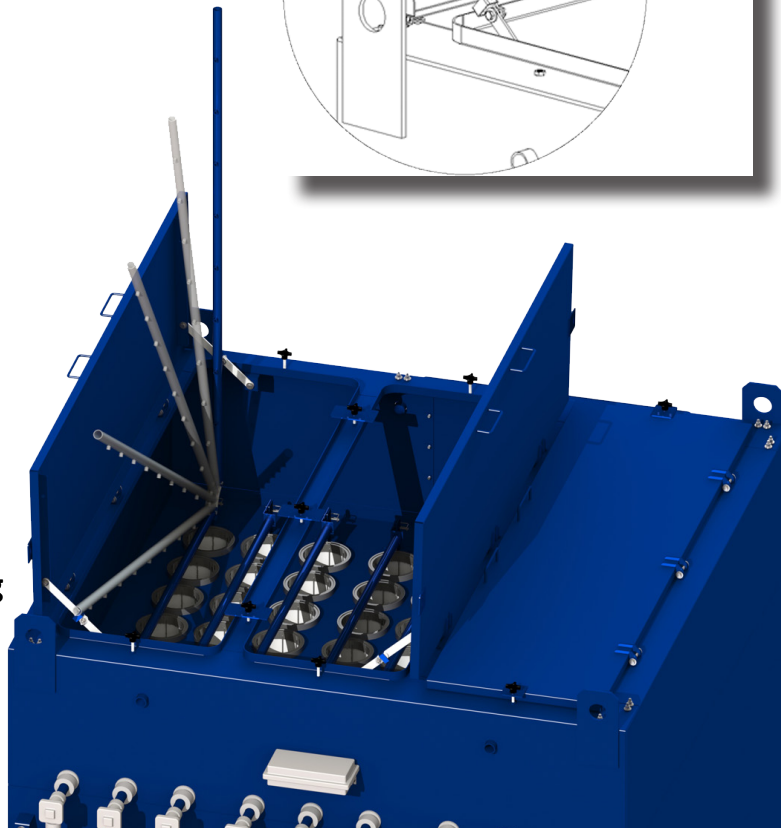

BAGHOUSE DIMENSIONS

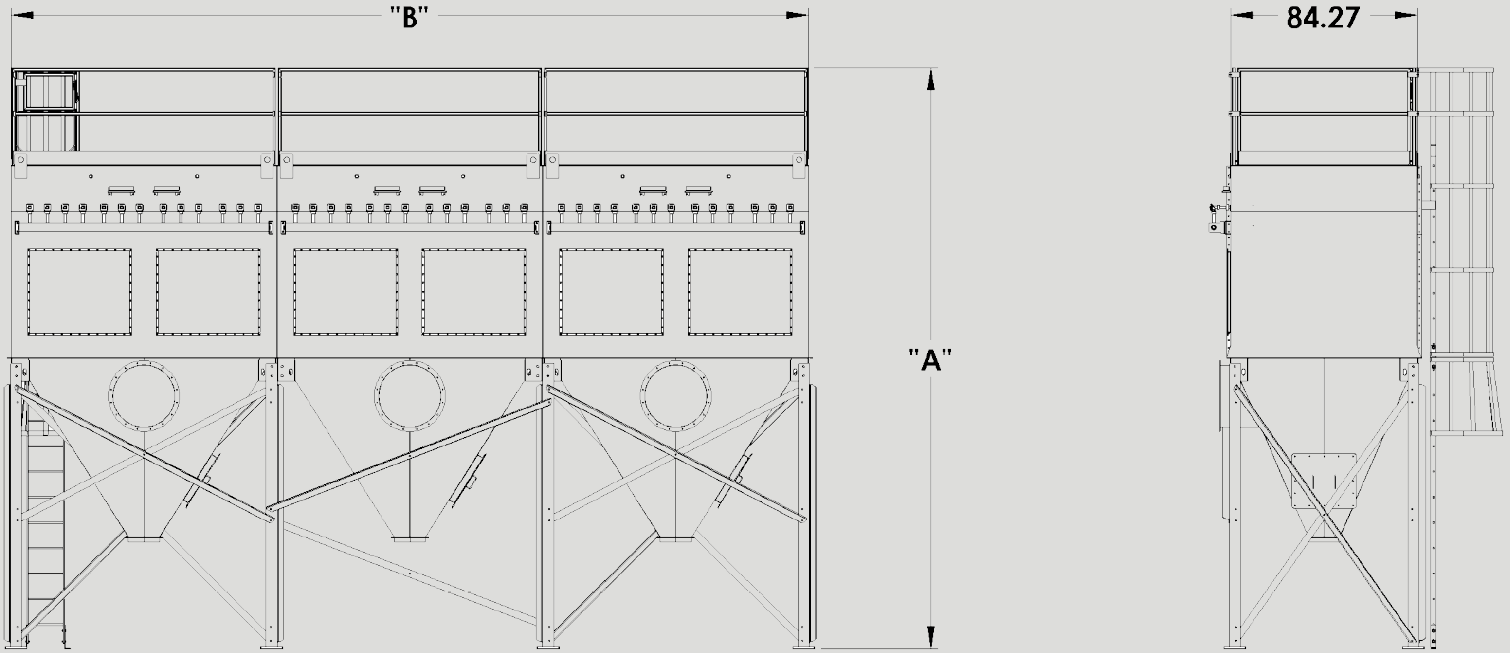

TLM 5 FT MODULES

MODEL	NOMINAL AIRFLOW RANGE (CFM)	FILTER MEDIA (FT ²)	# OF TLM 81 MODULES	# OF TLM 117 MODULES	# OF BAGS	# OF VALVES	BAG LENGTH (FT)	BAG DIAMETER (IN)	ESTIMATED SHIPPING WEIGHT (LBS)	DIMENSIONS	
										A	B
TLM 81-5	2,000-6,000	636	1	0	81	9	5	6	5,100	237.21	85.02
TLM 117-5	3,000-9,000	919	0	1	117	13	5	6	6,100	261.96	117.02
TLM 162-5	5,000-12,000	1,272	2	0	162	18	5	6	8,600	237.21	165.38
TLM 198-5	6,000-15,000	1,555	1	1	198	22	5	6	9,600	261.96	197.38
TLM 234-5	7,000-18,000	1,838	0	2	234	26	5	6	10,500	261.96	229.38
TLM 279-5	8,000-21,000	2,191	2	1	279	31	5	6	13,200	261.96	277.74
TLM 315-5	9,000-24,000	2,474	1	2	315	35	5	6	14,100	261.96	309.74
TLM 351-5	11,000-27,000	2,757	0	3	351	39	5	6	15,100	261.96	341.74
TLM 396-5	12,000-31,000	3,110	2	2	396	44	5	6	17,600	261.96	390.09
TLM 432-5	13,000-34,000	3,393	1	3	432	48	5	6	18,600	261.96	422.09
TLM 468-5	14,000-36,000	3,676	0	4	468	52	5	6	19,500	261.96	454.09
TLM 513-5	16,000-40,000	4,029	2	3	513	57	5	6	22,200	261.96	502.45
TLM 549-5	17,000-43,000	4,312	1	4	549	61	5	6	23,100	261.96	534.45
TLM 585-5	18,000-46,000	4,595	0	5	585	65	5	6	24,100	261.96	566.45
TLM 630-5	19,000-50,000	4,948	2	4	630	70	5	6	26,500	261.96	614.81
TLM 666-5	21,000-52,000	5,231	1	5	666	74	5	6	27,500	261.96	646.81
TLM 702-5	22,000-55,000	5,513	0	6	702	78	5	6	28,400	261.96	678.81
TLM 756-5	23,000-59,000	5,938	5	3	756	84	5	6	32,800	261.96	743.53
TLM 792-5	24,000-62,000	6,220	4	4	792	88	5	6	33,800	261.96	775.53

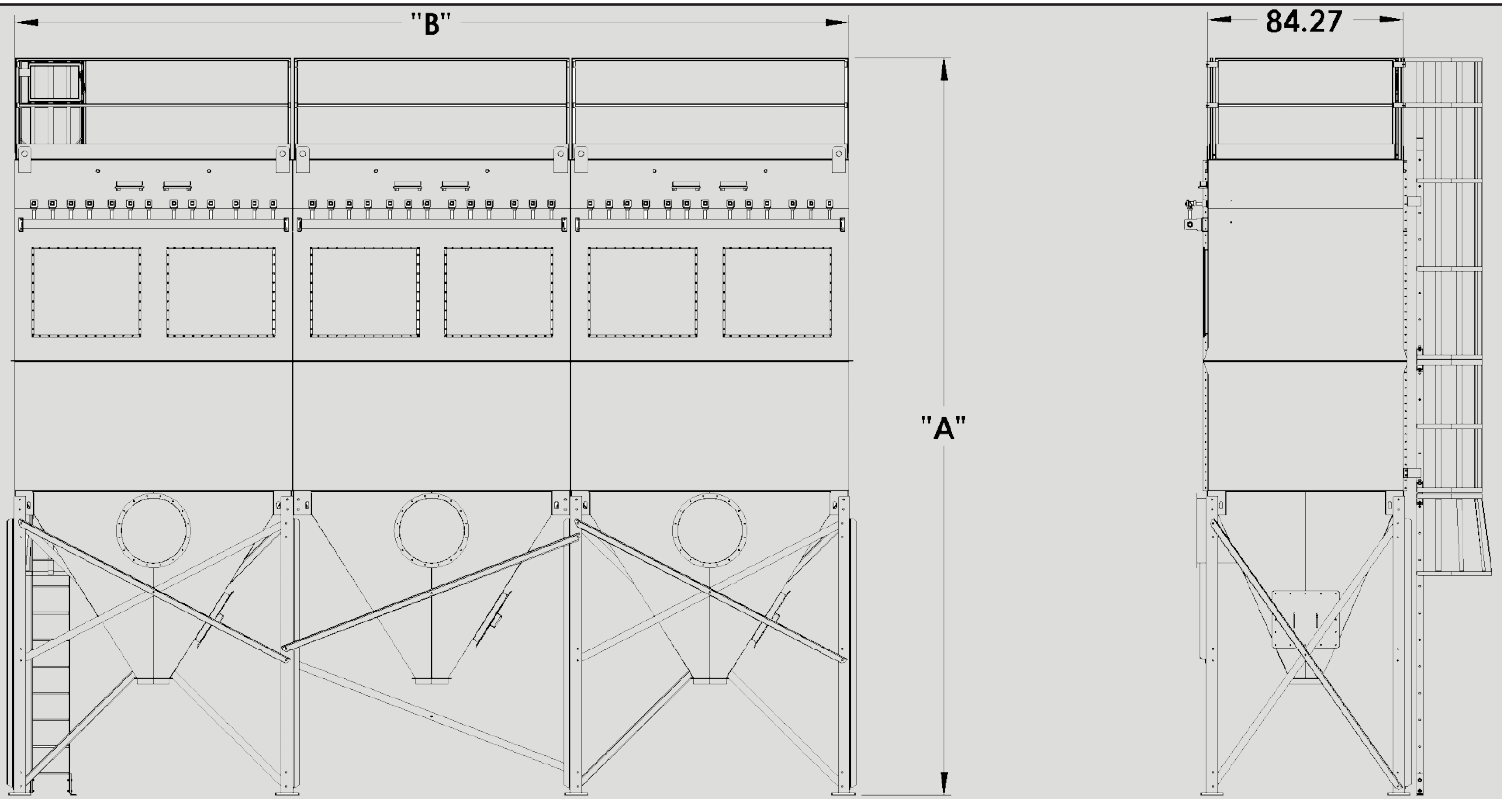

TLM 10 FT MODULES

MODEL	NOMINAL AIRFLOW RANGE (CFM)	FILTER MEDIA (FT ²)	# OF TLM 81 MODULES	# OF TLM 117 MODULES	# OF BAGS	# OF VALVES	BAG LENGTH (FT)	BAG DIAMETER (IN)	ESTIMATED SHIPPING WEIGHT (LBS)	DIMENSIONS	
										A	B
TLM 81-10	5,000-12,000	1,272	1	0	81	9	10	6	6,000	297.21	85.02
TLM 117-10	7,000-18,000	1,838	0	1	117	13	10	6	7,100	321.96	117.02
TLM 162-10	10,000-25,000	2,545	2	0	162	18	10	6	10,100	297.21	165.38
TLM 198-10	12,000-31,000	3,110	1	1	198	22	10	6	11,200	321.96	197.38
TLM 234-10	14,000-36,000	3,676	0	2	234	26	10	6	12,400	321.96	229.38
TLM 279-10	17,000-43,000	4,383	2	1	279	31	10	6	15,500	321.96	277.74
TLM 315-10	19,000-50,000	4,948	1	2	315	35	10	6	16,600	321.96	309.74
TLM 351-10	22,000-55,000	5,513	0	3	351	39	10	6	17,700	321.96	341.74
TLM 396-10	24,000-62,000	6,220	2	2	396	44	10	6	20,700	321.96	390.09
TLM 432-10	27,000-67,000	6,786	1	3	432	48	10	6	21,800	321.96	422.09
TLM 468-10	29,000-73,000	7,351	0	4	468	52	10	6	23,000	321.96	454.09
TLM 513-10	32,000-80,000	8,058	2	3	513	57	10	6	26,100	321.96	502.45
TLM 549-10	34,000-86,000	8,624	1	4	549	61	10	6	27,200	321.96	534.45
TLM 585-10	36,000-91,000	9,189	0	5	585	65	10	6	28,300	321.96	566.45
TLM 630-10	39,000-98,000	9,896	2	4	630	70	10	6	21,200	321.96	614.81
TLM 666-10	41,000-104,000	10,462	1	5	666	74	10	6	32,300	321.96	646.81
TLM 702-10	44,000-110,000	11,027	0	6	702	78	10	6	33,500	321.96	678.81
TLM 756-10	47,000-118,000	11,875	5	3	756	84	10	6	38,500	321.96	743.53
TLM 792-10	49,000-124,000	12,441	4	4	792	88	10	6	39,700	321.96	775.53

DESIGNED, ENGINEERED, AND MANUFACTURED IN USA



A.C.T. Dust Collectors
820 North Front St.
New Ulm, MN 56073
Toll-Free 800 422 1316
Phone 763 557 7162
Fax 763 557 9731
info@actdustcollectors.com
www.actdustcollectors.com



2020 DMM