

6

5

4

3

2

1

D

C

B

A

D

C

B

A

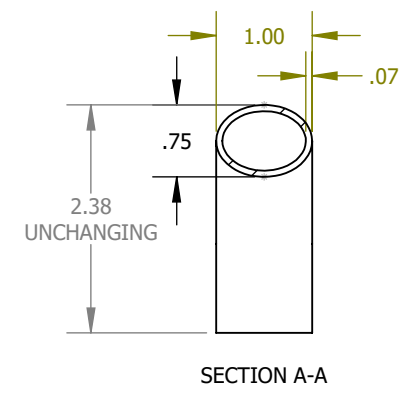
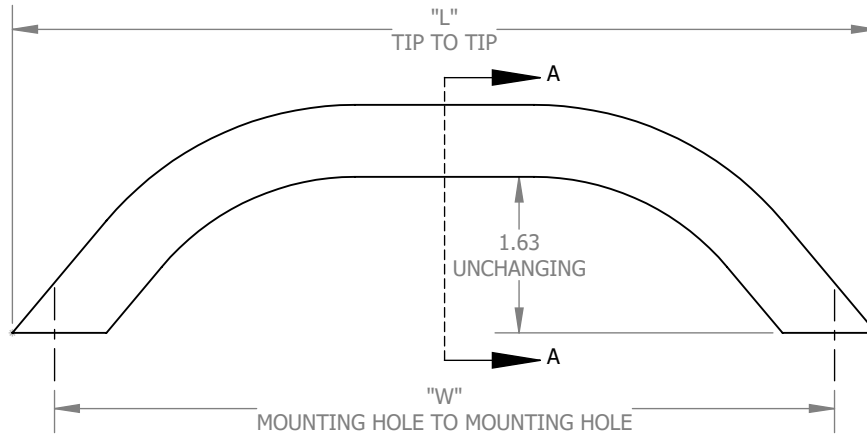

PART NUMBER	"L"	"W"="L"-.875
53109	9"	8.125"
53112	12"	11.125"
53114	14"	13.125"
53115	15"	14.125"
53118	18"	17.125"
53120	20"	19.125"
53122	22"	21.125
53124	24"	23.125
53130	30"	29.125
53136	36"	35.125

PROPRIETARY AND CONFIDENTIAL
 THE INFORMATION CONTAINED IN THIS DRAWING IS THE SOLE PROPERTY OF GG SCHMITT & SONS.
 ANY REPRODUCTION IN PART OR AS A WHOLE WITHOUT THE WRITTEN PERMISSION OF GG SCHMITT & SONS IS PROHIBITED.

THIRD ANGLE PROJECTION

 UNLESS OTHERWISE SPECIFIED: DIMENSIONS ARE IN INCHES [SECONDARY IS IN MILLIMETERS]
 TOLERANCES:
 FRACTIONAL: 1/16"
 ANGLE: ± 5°
 XX ± .03", XXX ± .010
 INTERPRET DIM AND TOL PER ASME 14.5M-1994

DESCRIPTION
RAIL, GRAB OVAL- NO STUDS
 DRAWN **CONOR W** 8/12/2021
 CHECKED

GG Schmitt & Sons
 PART NO. **SEE TABLE**
 REV
 SCALE **1:2** DO NOT SCALE DRAWING SIZE **A** SHEET **1 OF 1**

6

5

4

3

2

1