

6

5

4

3

2

1

D

D

C

C

B

B

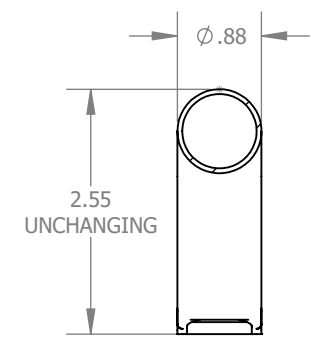
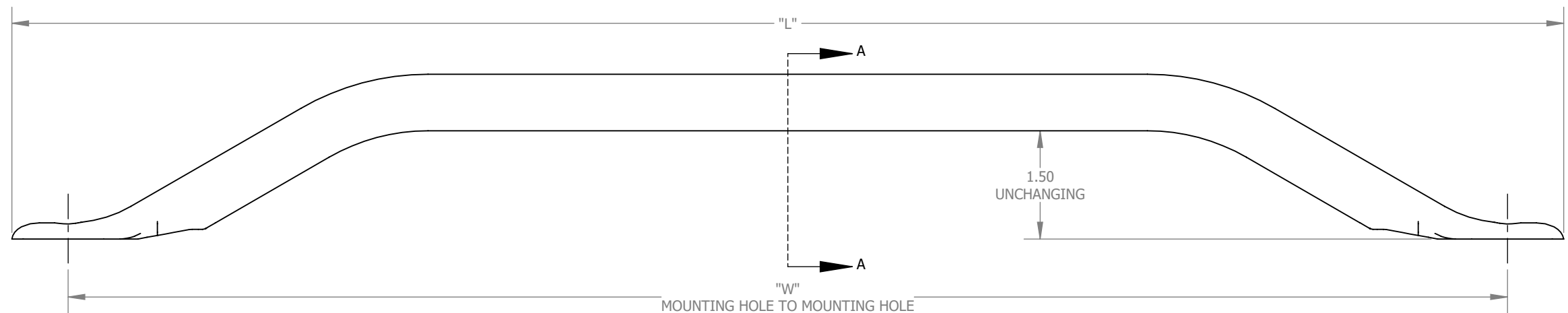
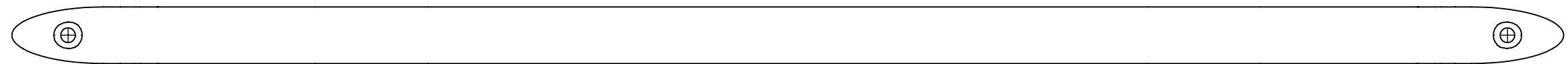

SECTION A-A  
SCALE 1 : 2

A

A

PART NUMBER	"L"	"W"="L"-1.5	PROPRIETARY AND CONFIDENTIAL	THIRD ANGLE PROJECTION	DESCRIPTION	GG Schmitt & Sons						
52011	15"	13.5"	THE INFORMATION CONTAINED IN THIS DRAWING IS THE SOLE PROPERTY OF GG SCHMITT & SONS.  ANY REPRODUCTION IN PART OR AS A WHOLE WITHOUT THE WRITTEN PERMISSION OF GG SCHMITT & SONS IS PROHIBITED.	 UNLESS OTHERWISE SPECIFIED: DIMENSIONS ARE IN INCHES [SECONDARY IS IN MILLIMETERS] TOLERANCES: FRACTIONAL: ± 1/16" ANGLE: ± 5° .XX ± .03", .XXX ± .010 INTERPRET DIM AND TOL PER ASME 14.5M-1994	<b>RAIL, GRAB SS FORMED END MFG</b>	PART NO. <b>SEE TABLE</b>		REV				
52021	18"	16.5"				DRAWN	CONOR W	8/21/2021	SCALE 1:2	DO NOT SCALE DRAWING	SIZE B	SHEET 1 OF 1
52031	20"	18.5"				CHECKED						
52041	24"	22.5"										
52051	30"	28.5"										
52061	36"	34.5"										

6

5

4

3

2

1