

**AUSTRALIAN
MEAT PROCESSOR
CORPORATION (AMPC)**

Suite 2, Level 6
99 Walker Street
North Sydney NSW 2060

PO Box 6418
North Sydney NSW 2059

02 8908 5500
admin@ampc.com.au
ampc.com.au

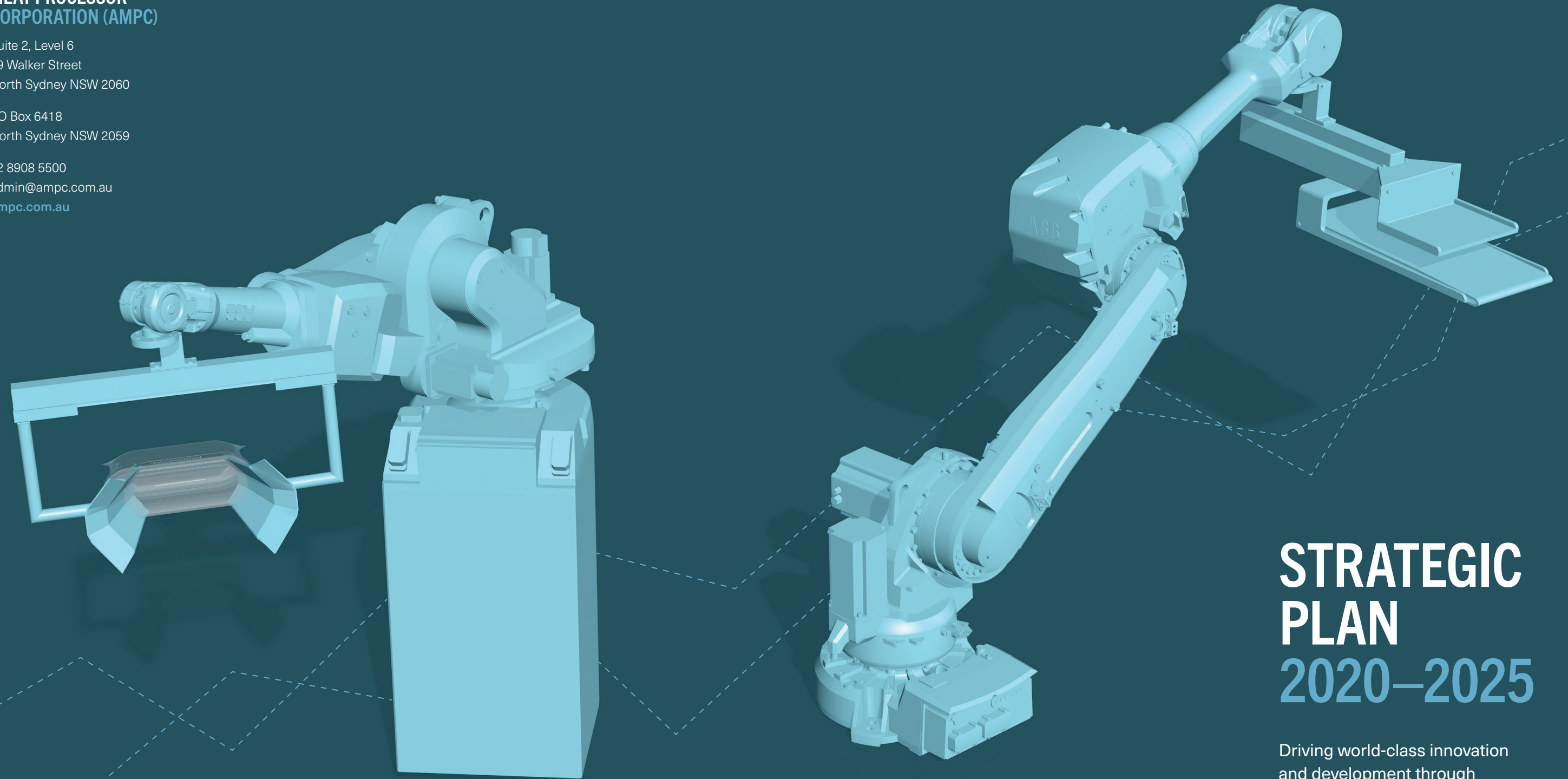

**STRATEGIC
PLAN
2020–2025**

Driving world-class innovation
and development through
genuine partnerships.

THIS STRATEGY RESETS THE FOCUS, PRIORITIES AND SERVICE DELIVERY FOR AMPC'S RESEARCH AND DEVELOPMENT PORTFOLIO.

With a **renewed vision** the organisation strives for innovation through continuous improvement, providing the greatest value for levies and monies invested.

This plan is underpinned by the meat industry's strategic priorities, Red Meat 2030, the rural research development and extension priorities and the national science and research priorities.

With that foundation, AMPC has engaged, consulted and developed its 2025 Strategic Plan with key stakeholders and has received their endorsement.

Red meat processors are positioned in the middle of the supply chain, between the farm and the end consumer. AMPC's members are considered part of agriculture by the industry's stakeholders but their role in creating value is beyond the farmgate.

Our members are manufacturers, some large and some small, supplying locally but all contributing to their local economies.

Red meat processors manage the commercial risks of securing the supply of livestock, they process at a higher cost than international competitors, and sell into highly competitive domestic and international markets.

Regardless of size, they all experience similar issues. Members look to AMPC for leadership in R&D that supports their unique position in the value chain.

AMPC HERE FOR PROCESSORS

Contents

About AMPC	3
Service Delivery	4
Programs	6
— Advanced Manufacturing	6
— Sustainability	10
— People & Culture	16
— Technical Market Access & Markets	20
— Product & Process Integrity	24
Financials	28
Research Priorities	30

ABOUT AMPC

AMPC is the rural research and development corporation for the red meat processing industry in Australia. As the **research, development** and **marketing** service provider for Australian processors, AMPC runs programs of activity that are funded by processor levy payers, private contributions and the Australian Government.

OUR MANDATE IS TO PROVIDE RESEARCH, DEVELOPMENT, EXTENSION AND MARKETING SERVICES THAT IMPROVE THE PRODUCTIVITY, PROFITABILITY AND SUSTAINABILITY OF THE INDUSTRY

Red meat processor levies are strategically invested in programs that deliver a range of benefits for the industry and the broader Australian community.

We engage leading research organisations and fund joint activities with our value-chain partner Meat & Livestock Australia (MLA) to address the priorities of the processing sector.

To complement the strategy an annual operating plan is prepared annually to guide the delivery of AMPC's long-term investment priorities and outcomes. The programs within our R&D portfolio have been constructed from direct engagement with our members and in partnership with the Australian Meat Industry Council (AMIC) to maximise the value of programs to levy payers.

Our Mission

To drive world-class **innovation, adoption** and strategic **policy** development through genuine partnerships built on trust.

Our Vision

The red meat processing industry's trusted partner in **innovation**.

Our Purpose

To enable Australia to build the most **competitive, profitable** and **sustainable** red meat processing industry.

SERVICE DELIVERY

We recognise the size of a processor's operations affects engagement with R&D priorities and the adoption of innovations.

Our program portfolio is segmented at project inception to design extension activities and understand adoption pathways to deliver clear value to all levy payers.

The AMPC team possess a unique understanding of the context of an issue and why it poses an opportunity for R&D. Our experience stretches across industry, science, research, private and public companies. Through consultation and engaging world-leading research scientists, universities and subject matter experts in our research and development, AMPC's insights make a positive difference to advancing the industry.

AMPC's peak industry council, the Australian Meat Industry Council, is the vehicle for processor advocacy and policy development. To gain the acknowledgement and support of other red meat participants, and in turn their communities, consumers and government, processors must develop a unified narrative. To facilitate the best outcomes for the sector AMPC has prioritised a renewed focus on policy research to support and inform the work AMIC do in policy development.

INSIGHTS

We deliver value through insights. Creating and simply having knowledge is not enough. Insight definition takes work; it's a skill that requires creativity, persistence and deep thinking to craft. The most powerful insights come from rigour and serious analysis to translate large amounts of data into concise and compelling findings.

ISSUES

- Animal Welfare & Social Licence
- Labour
- Energy
- Market Access
- Water & Waste
- Technology, Automation & Productivity
- Regulatory Burden
- Packaging
- Herd Levels
- Consumer Trends & Education

STAKEHOLDERS

- Government
- Industry Bodies
- Producers
- Community
- Customers
- Consumers

PROVIDERS

- Scientists
- Engineers
- Consultants
- Research Partners
- Service Providers

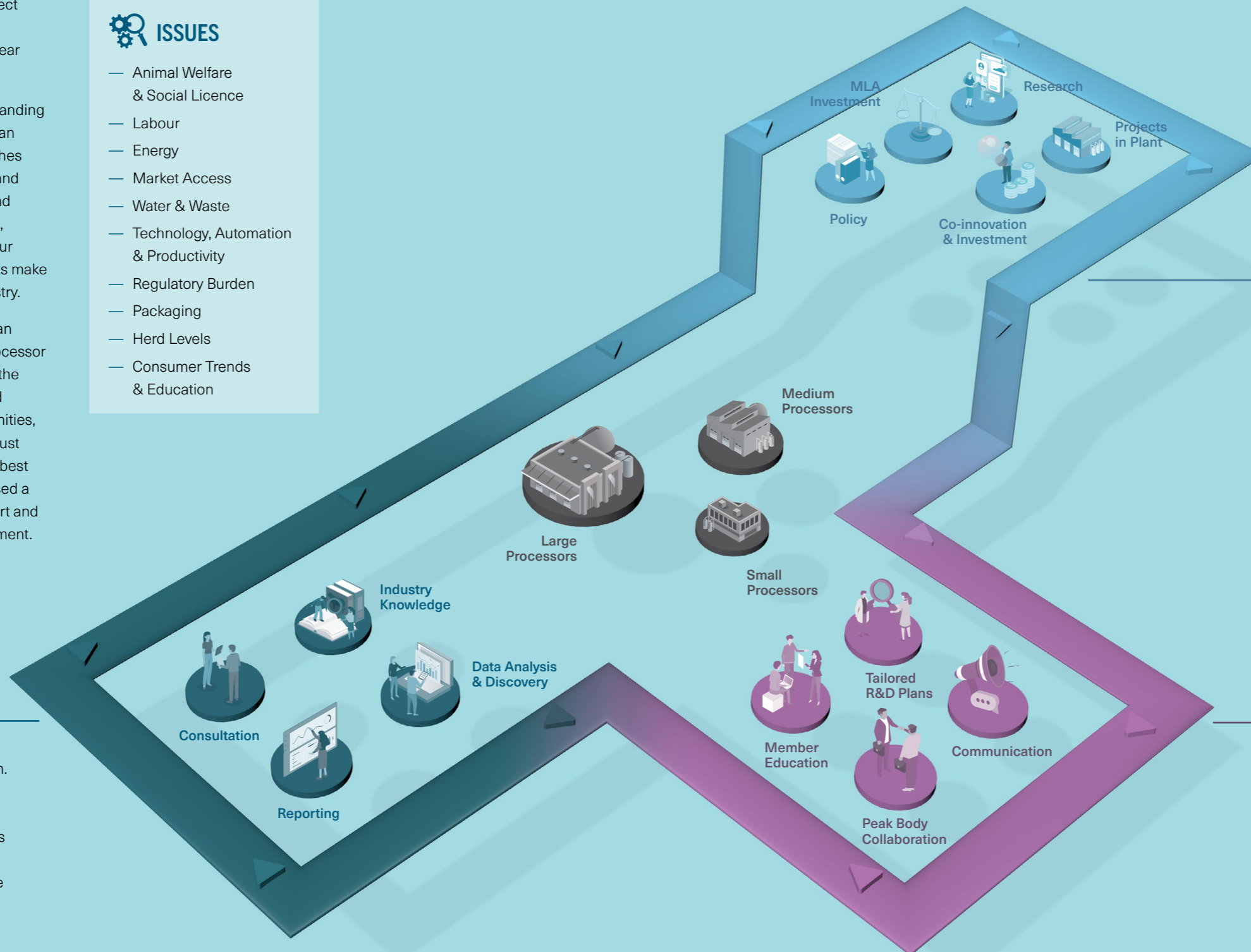

RESEARCH & DEVELOPMENT

Research and development consists of investigative activities that AMPC selects through consultation with industry with the desired result of a discovery that will either add value by creating an entirely new product, product line/service or increases productivity and efficiency. The aspiration is that R&D efforts lead to an improved type of business process — cutting marginal costs or increasing marginal productivity — it is easier to outpace global competitors.

EXTENSION & ADOPTION

AMPC members are businesses of varying sizes and have different operational needs, for R&D leadership AMPC is their trusted advisor. Whether it is practical best practice guides for staff training or an automated technology which optimises export traceability. R&D to benefit all members and our industry is achieved together, through partnership.

ADVANCED MANUFACTURING

Program Aspiration

HUMAN PRODUCT HANDLING IS HALVED THROUGH TECHNOLOGY ADVANCEMENT TO REDUCE INJURY RATES, MAXIMISE YIELD AND PROCESSING EFFICIENCY BY 2030.

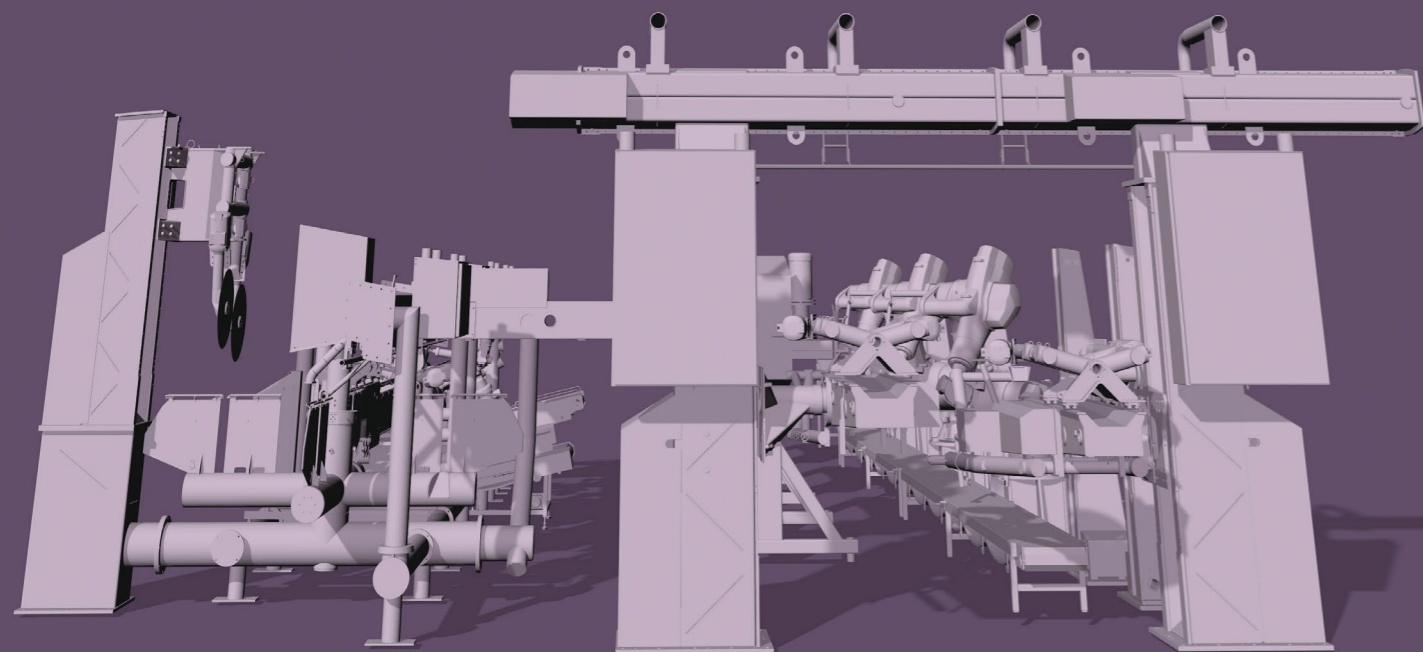

Advanced manufacturing offers enormous opportunity for R&D to improve efficiency of operations for meat processors of all sizes.

In the next five years innovation in business profitability will come from improving efficiency, decreased costs including reduction in lost time injuries, but also from increases in throughput, yield optimisation, and ensuring carcasses are processed to achieve maximum market returns.

AMPC recognises the significant investment individual businesses make in their operations and is committed to maximising the value of levy funds in advanced manufacturing projects through consultation with members.

Industry 4.0

While recognising the short-term opportunities for R&D, commercialisation and adoption, this strategic plan for advanced manufacturing boldly aims to look further than what can be achieved in the 5-year horizon.

The term industry 4.0 is used to describe the push for smart factories and smart manufacturing where machines which are augmented with wireless connectivity and sensors are connected to a system that can visualise the entire production line and make decisions on its own. The first challenge is to identify what the opportunity represents for processing plants.

Objective Measurement

As technology progresses through R&D so too will the accuracy of current carcass segmentation and deboning yields. Over the next five years, feasibility studies and the development of objective measurement systems supported by carcass cut calculators and optimisers will aim to deliver the highest returns possible for primal cuts subject to markets available to each processor.

Hands-Off Solutions

Providing a safer work environment through assistive processing tools or automation of tasks has the potential to increase accuracy, eliminate handling injuries and lift productivity. Research into sensing technologies, tactile and visual aids will enable the development of tools for commercial use.

Investment & Adoption

To facilitate technology adoption, it is imperative that alternative commercial adoption arrangements are examined to give the sector the ability to move quickly to adopt new technologies that improve efficiency and profitability. Furthermore, when research and development efforts are successful in producing an outcome which can be commercialised, the practical adoption of that knowledge must be extended to the sector.

AMPC's service delivery model is well-positioned to enhance the understanding and accessibility of R&D innovations to small, medium and large processors.

HANDS-OFF PROCESSING

Objectives	Initiatives
Yield-critical cutting lines, slaughter and boning, have their required sensing and cutting research completed by 2025	<ul style="list-style-type: none"> — Sensing and cutting feasibility studies — Technology development and in-plant trials for viable sensing solutions
Tasks that can be undertaken in a hands-off method have feasibility research completed by 2030	<ul style="list-style-type: none"> — Identify all hands-on tasks to be made safer — Development of tactile and visual aids — In-plant trials of technical and commercially viable solutions — Identify alternatives to existing ways of product movement
Complete research for hands-on tasks to potentially eliminate lost time injury claims	<ul style="list-style-type: none"> — In-plant trials of technical and commercially viable solutions

ADOPTION

Objective	Initiatives
Increase adoption of commercial innovation solutions to 80% of market opportunity within 10 years of commercialisation commencing	<ul style="list-style-type: none"> — Co-development of new business models between processors and suppliers — Evaluation of industry friendly loans (or equivalent commercial adoption models) — Support the continued development of industry knowledge and skills evolution to enable adoption

DIGITISATION

Objective	Initiative
Assess whether Industry 4.0 is an achievable opportunity for processing plants	<ul style="list-style-type: none"> — Pilot programs to investigate how Industry 4.0 thinking can assist businesses

CARCASE PRIMAL PROFITABILITY OPTIMISATION

Objectives	Initiatives
Complete research on the identification of all objective carcass measurements and benefit evaluation	<ul style="list-style-type: none"> — Research into objective measurement systems needed to optimise boning room scheduling
Industry beef and sheep carcass cuts calculators are developed and refined by 2025	<ul style="list-style-type: none"> — Finalisation of beef and lamb carcass cuts generic models
80% of processors with objective carcass measurement (OCM) systems have implemented business specific refined carcass cuts calculators, with chiller product optimisation solutions, by 2030	<ul style="list-style-type: none"> — Processor support for adoption of industry generic models



STRATEGIC POLICY RESEARCH

Objective	Initiatives
Improve supply chain efficiency	<ul style="list-style-type: none"> — Research Australian red meat productivity — Benchmark productivity: Australia vs Global benchmark — Annual productivity review for the sector — Develop projects to inform and support policy development that enables industry productivity and aids advocacy strategies

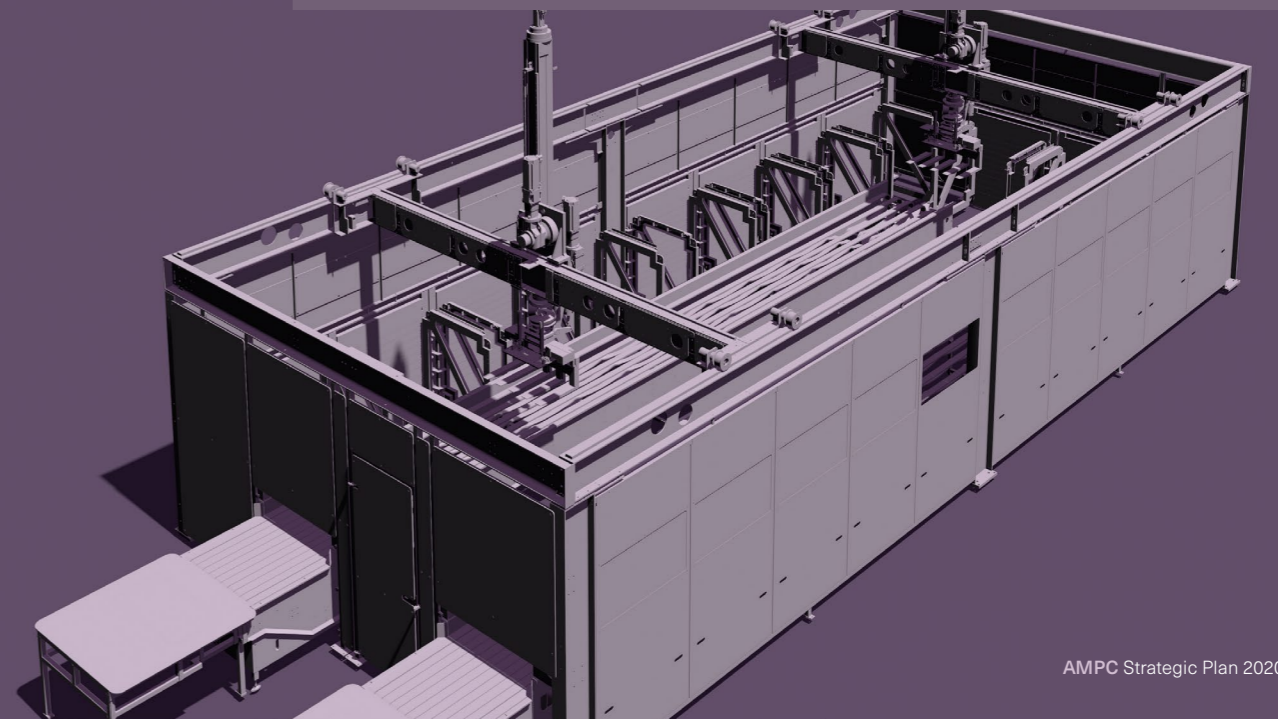

SUSTAINABILITY

Program Aspiration

BY 2030, AUSTRALIAN PROCESSORS ARE RECOGNISED AS GLOBAL LEADERS IN ENVIRONMENTAL STEWARDSHIP AND ACKNOWLEDGED AS RESPONSIBLE BUSINESSES WITH POSITIVE ECONOMIC AND SOCIAL IMPACTS ON THEIR COMMUNITIES.

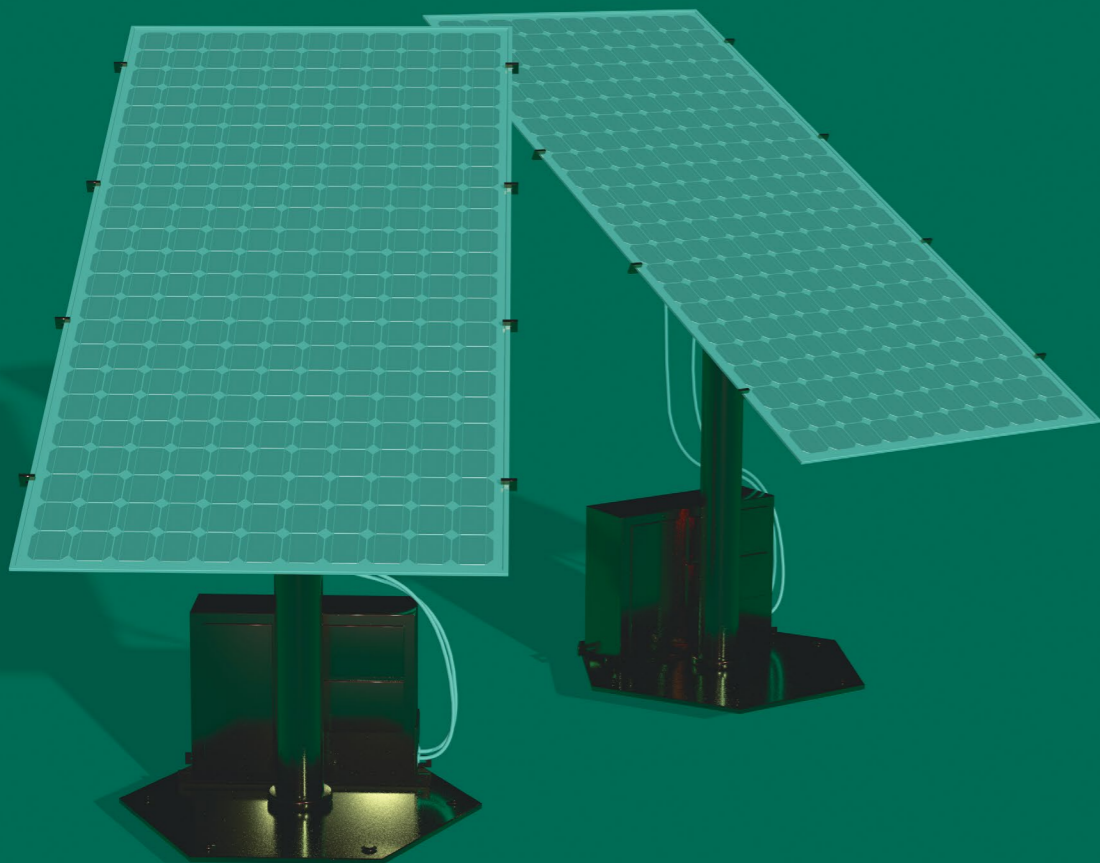

Red meat processing is currently responsible for **0.24%** of Australia's gross domestic emissions, equating to **2%** of the emissions for the whole red meat industry.¹

Average emissions intensity for processing continues to fall (eg down 22% between 2009–2015²) and the sector is committed to the red meat industry target of CN30. In realising this commitment, processors will better communicate the positive actions they are taking and the associated benefits for their communities.

The first step in achieving this will be enhancing data collection and reporting to help benchmark and manage continuous improvement in water, waste and energy use across the sector.

Communities

Research, development, extension and adoption across the focus areas within Sustainability is critical in demonstrating achievement of consumer, customer, community and stakeholder expectations for our sector. AMPC seeks to help strengthen the processing sector's economic resilience through investment in R&D that leads to reduced costs and improved productivity for our members.

Our Sustainability program aligns with the Beef and Sheep sustainability frameworks as well as the red meat industry's carbon neutral target by 2030 (CN30). The Sustainability program recognises that red meat processing has environmental impacts and that work needs to continue to address energy, water, waste and packaging to safeguard our industry and create sustainable communities for future generations.

Energy

Whilst the average energy intensity for processing red meat has reduced by 9.30% over the last decade,⁴ continued efforts are needed to mitigate the effects of further energy price volatility and to make further savings. Realising more viable options for renewable energy generation, reliability and continuity of supply and best practices in energy efficiency is common to all processors.

More efficiently assessing the costs of implementation, and optimising the returns on investment, are both strategic priorities for businesses. There is no "one size fits all" approach and the initiatives in this five-year plan address these anomalies.

Water

Red meat processing plants are unique in terms of their varying water sources, consumption, treatment methods, discharges and end use. Australia is more severely impacted by water scarcity than any other inhabited continent on earth, so RDE&A in this area must address not only the economic benefits of water reduction, reuse and recycling but also the water stewardship standards expected by communities across Australia and the globe.

In the next five years water quality and reliability of supply will continue to be impacted by increasing risks for all processors and better on-plant water treatment practices and infrastructure needs to be developed and adopted.

Waste

Processors continue to reduce their footprint in solid waste to landfill intensity (eg reduced by 77% between 2003–2015⁵). However, environmental protection authorities are now more pro-active, and plants will be required to achieve "zero waste to landfill".

As a result, processor plants will find it more difficult to dispose of their wastes. Therefore, RDE&A in this area is focused on identifying solutions that recycle or re-process nearly all wastes while providing potential for alternative revenue streams.

Packaging

Similarly, packaging can present waste disposal issues for the circular economy. Sustainable packaging needs to be developed for the sector to provide biodegradable and recyclable options while maintaining the food safety and shelf life standards. Our food safety and standards have secured a unique position for Australian red meat across domestic and international markets.

¹ AMPC Emissions Pathway 2019-1059.
² AMPC Environmental Review 2013-5047, 432 kg CO₂e / tHSCW (2015). Numbers normalised for cattle and render.
³ AMPC Costs to Operate 2019-1011.
⁴ AMPC Water Recycling Opportunities 2018-1030, 3726 MJ / tHSCW (2019) and AMPC Environmental 2013-5047, 4108 MJ / tHSCW (2009). Numbers normalised for cattle and render.
⁵ AMPC Environmental 2013-5047, 5.80 kg / tHSCW (2015). Numbers normalised for cattle and render.

COMMUNITIES

Objectives	Initiatives
Capture 80% of processors' measured and reported data on annual emissions	<ul style="list-style-type: none"> — 2020 environmental survey — De-identified data reporting — Emissions pathway for CN2030* — Environmental certification schemes
80% of regional processors reporting progress annually on their cooperation with regional resource management groups	<ul style="list-style-type: none"> — Improved public information and engagement — Nil noise and odour complaints — Predictive inventory resilience management technologies
Promote good news on processors based on facts and science to key stakeholders locally and globally	<ul style="list-style-type: none"> — Improved relationships in regional communities — Improved transparency in global processor communities and consumer markets — Driving better outcomes with marketing and government supported working groups

STRATEGIC POLICY RESEARCH

Objective	Initiative
Attraction and retention of workforce	— Policy supporting services and infrastructure

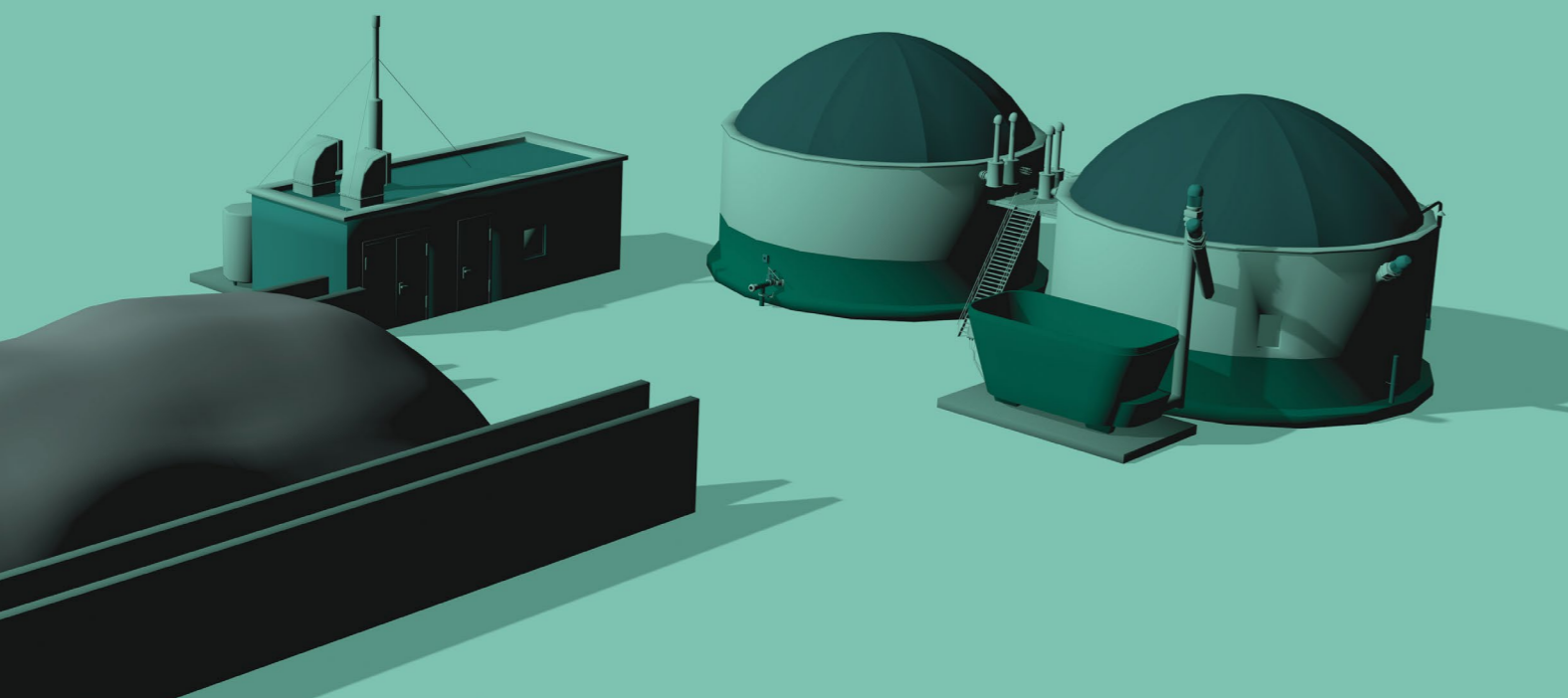

ENERGY

Objectives	Initiatives
50% (by throughput) measured plant annual energy use, with de-identified public portal reporting by 2025	<ul style="list-style-type: none"> — Energy monitoring with diagnostic capabilities — Machine learning with predictive maintenance alerts — Industry 4.0 integration and automated reporting — Best practice energy management — Smart energy management systems investigation — Energy benchmarking and savings opportunity tool
A further 10% reduction in energy intensity by 2025 through energy efficient practices and technologies	<ul style="list-style-type: none"> — Refrigeration Energy Efficiency Opportunity workshops — Buying groups — New process heat technologies — Smart applications — Retro-fit product awareness
100% renewable electricity use by 2030, subject to feasible grid connection in each plant location	<ul style="list-style-type: none"> — Renewable energy investment calculators — Business funding models — Energy storage technology comparisons — Grid connectivity and flexibility — Industry policy — Solutions for localised distributed energy
Five feasible piloted alternatives to grid gas and fossil fuel use by 2025	<ul style="list-style-type: none"> — Hydrogen and biogas national roadmap — Biomass next generation energy tech — Aggregated waste to energy solutions

STRATEGIC POLICY RESEARCH

Objective	Initiatives
Decrease energy costs	<ul style="list-style-type: none"> — Future energy pricing scenarios — Industry policy for renewable energy transition

WATER

Objectives	Initiatives
50% (ie by throughput) measured plant annual water use, with de-identified public portal reporting by 2025	<ul style="list-style-type: none"> — Sub-process level water use — Industry 4.0 integration — Beef Sustainability Framework adoption — Water benchmarking and savings opportunity tool
A further 5% reduction in water intensity by 2025 through water efficient practices and technologies	<ul style="list-style-type: none"> — Water re-use / recycling decision making matrix — Equipment and process scan — Business models (eg water savings or wastewater treatments “as a service”) — Small equipment retrofits
50% (ie by throughput) annual demonstration of best practice water stewardship by 2025	<ul style="list-style-type: none"> — Dealing with retentates and discharges — Non-chemical alternatives in wastewater treatment — Australian Water Stewardship standards — Localised water policies
50% adoption (ie by throughput) of advanced water-recycling by 2030	<ul style="list-style-type: none"> — Water recycling technologies — Techno-economic feasibility for water recycling — Global best practice water recycling pilots — Market equivalence for direct planned potable water recycling — Industry policy support for recycled water



STRATEGIC POLICY RESEARCH

Objective	Initiative
Increase in-plant water recycling	— Industry policy for recycled water

WASTE

Objectives	Initiatives
A further 50% reduction in solid waste to landfill by 2030	<ul style="list-style-type: none"> — Aggregating localised wastes for regional energy — Rural R&D 4 Profit — Wastes to Profit Program — Utilisation of solid wastes in dual fuel biomass boilers — Scalable technologies to suit varying waste volumes — Integrative opportunities for energy, water and waste projects — Benchmarking & savings opportunity tool
Five feasible piloted alternatives for solid/liquid waste treatment and recycling and elimination of avoidable contaminants by 2025	<ul style="list-style-type: none"> — Alternative waste treatment technologies and processes — Renderable plugs and clips — Detection and removal and/or avoidance of contaminants — Alternative by-products and value add for niche markets (eg animal feeds) — Industry policy for minimising untreated or non-recycled waste streams



STRATEGIC POLICY RESEARCH

Objective	Initiative
Decrease waste disposal costs	— Industry policy for untreated or non-recycled waste streams

PACKAGING

Objective	Initiatives
A feasible piloted alternative for red meat sustainable food packaging by 2025	<ul style="list-style-type: none"> — National Packaging Covenant — Food safety and shelf life implications — Presentation, provenance and consumer implications — Export and trade implications — Integration of technological change and business implications

PEOPLE & CULTURE

Program Aspiration

BY 2030, THE PROCESSING SECTOR IS SEEN AS A DIVERSE, SAFE AND ATTRACTIVE INDUSTRY OF CHOICE FOR EMPLOYMENT.



The red meat processing sector contributes about **100,000 direct and indirect jobs** in Australia, mostly located in regional areas.

Out of the 95 processors currently in operation, 60% are in regional areas and it can be especially difficult to fill roles in these locations.

Many abattoirs are the largest employer in their town (or region) making red meat processing an important driver for jobs and growth in regional communities. This can be evidenced by multiple (16) proposed new abattoirs in regional areas over the next 5 years. (ACIL Allen, 2019)

Labour attraction and retention is critical to the sector's success. It is the single highest input cost for red meat processors at nearly 60% of total operating costs (excluding the cost of livestock) (Helibron, 2018).

Attraction

The processing sector offers a diverse range of stable job opportunities. However, small, medium and large processors have been unable to attract and retain people on a long-term basis and employee turnover remains high, adding considerable cost to business. Research and development over the next five years is focused on addressing the sector's image and changing current perceptions to attract a talented, diverse and dedicated workforce.

Retention

Often seen as an industry for short-term employment, a recent study revealed the current average turnover rate is 61%. There is significant opportunity to invest in best practice frameworks to retain talent and embed cultural change.

Development

The processing industry has well-established development opportunities. Initiatives in this area will bolster the industry's leadership capability. The sector must also continue to scan the environment to ensure it is equipping its workforce with the right skills for future success.

Safety & Wellbeing

Regarded as a high-risk, high manual handling industry, processing is not recognised as having embedded employee wellness programs. The experience of other industries shows that workplace wellness programs help create a win-win situation which has a positive impact on both employees and employers. Benefits include reduced employer costs and employee stress as well as increased morale and improved relationships. It is an extension of safety culture and practices which drives improved outcomes.

ATTRACTION

Objective

By 2030 be seen as a **vibrant and progressive industry** of choice for employment, offering a diverse range of careers underpinned by a vast range of training options

Initiatives

- Focused industry branding
- Candidate attraction and training
- Attract people from diverse backgrounds to the sector
- Understanding barriers to internal attraction
- Mentoring programs to support the sector

RETENTION

Objectives

Halve the industry baseline **turnover rate** (current average 61%) from 2020 to 2030

By 2025 have embedded **cultural change practice frameworks** within the sector to enable meeting the 2030 target

Initiatives

- Best practice human resources frameworks
- Best practice human resources frameworks



STRATEGIC POLICY RESEARCH

Objective

Attraction and retention of workforce

Initiatives

- Future workforce policy
- Strengthening community relationships
- Unified industry narrative

DEVELOPMENT

Objective

A highly skilled sector with ongoing development opportunities and support mechanisms, demonstrating best practice and future job growth

Initiatives

- Leadership capability development
- Learning platforms for the future
- Future workforce development
- Skilling the jobs of the future
- Upskilling
- Continuous improvement in innovation adoption

SAFETY & WELLBEING

Objectives

Industry is seen as having sound safety and wellbeing practices that **reduce the incident rates 30% by 2030**

Reduce absenteeism by 25% by 2025

Initiatives

- Safety culture
- Work practices to reduce hands-on processing
- Improving employee wellness
- Understanding the drivers of absenteeism

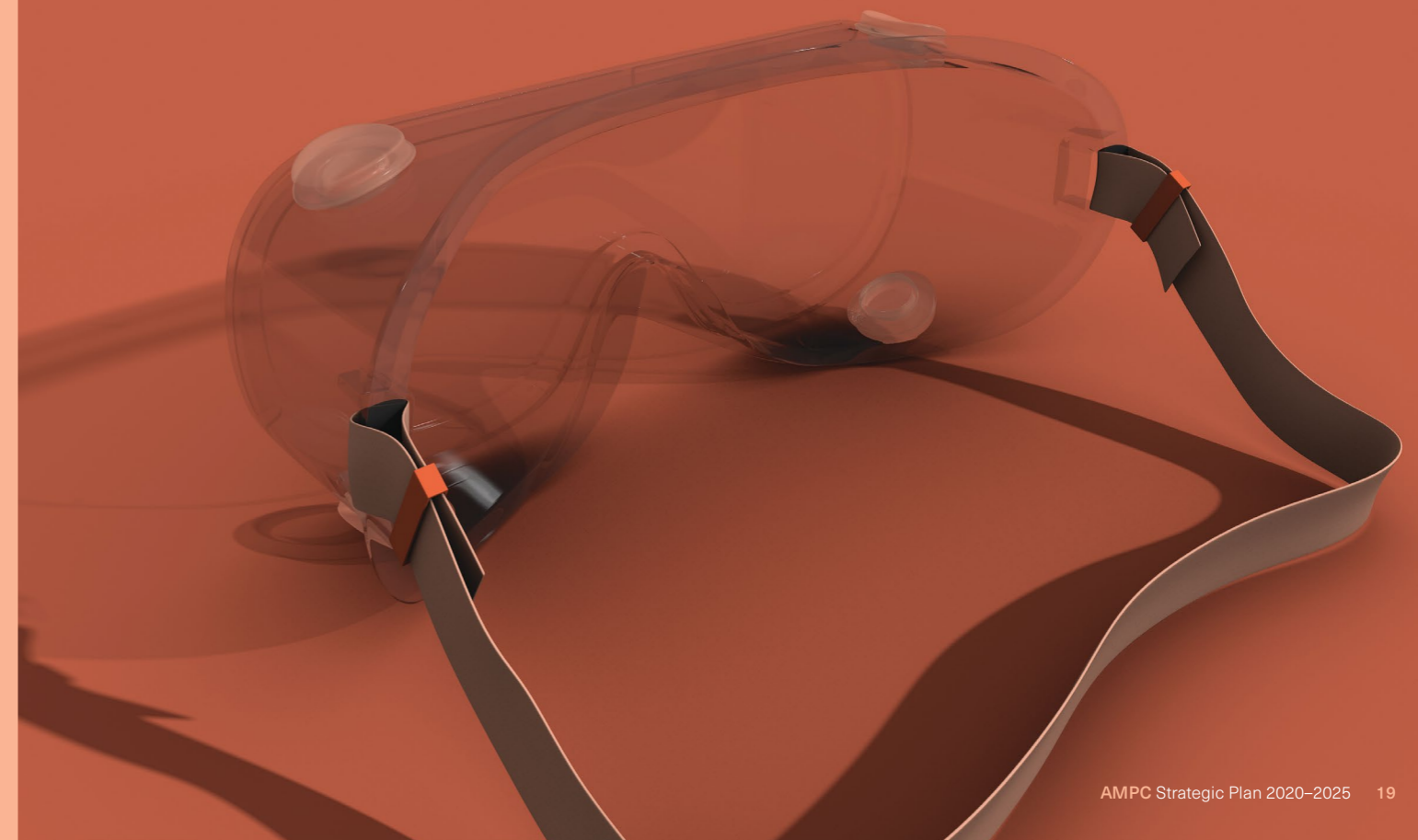



TECHNICAL MARKET ACCESS & MARKETS

Program Aspiration

BY 2030, AUSTRALIA IS THE PREFERRED TRADING PARTNER FOR PREMIUM RED MEAT PRODUCTS GLOBALLY, WITH UNRIVALLED ACCESS TO HIGH VALUE MARKETS.

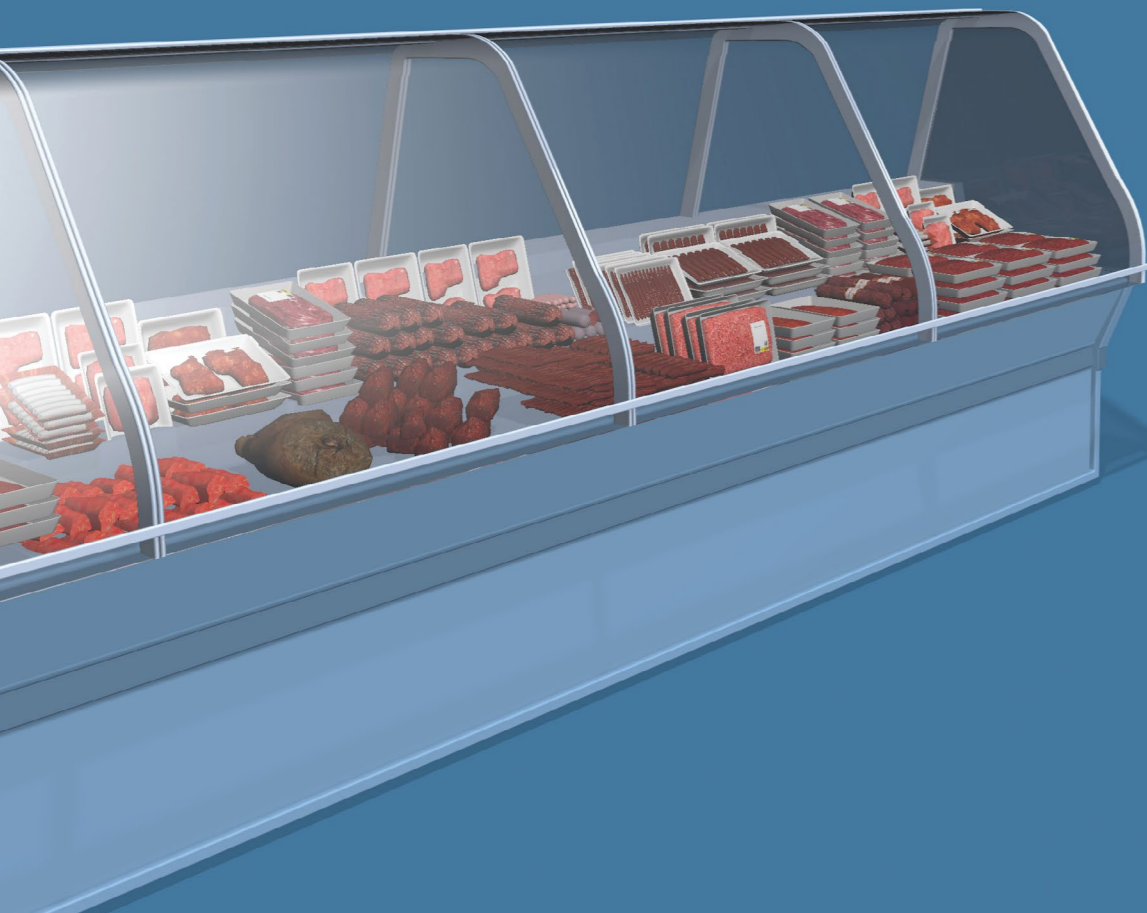

With Australian red meat facing increasing competition from other meat suppliers and protein products in global markets, the industry must continue to promote its exceptional points of difference to global customers and consumers — **safety, quality and traceability.**

At home, in the domestic market, the focus is to ensure beef and lamb remain popular meal choices by focusing on Australian red meat's value proposition and business development.

In response, AMPC collaborates with industry stakeholders including the Australian Government, MLA and peak industry council AMIC to drive growth in exports and deliver a greater impact for domestic demand than what could be achieved alone.

Marketing & Promotion

The global competitiveness of the Australian meat processing sector is maximised through market access and effective consumer marketing. Domestically, where market penetration is high, there is opportunity to increase the frequency of consumer purchase patterns for red meat. Better understanding of international consumers and premium markets is a ripe opportunity for processors. AMPC will work closely with MLA to drive a marketing program that maximises returns to industry.

Australia also needs to differentiate and articulate the unique value proposition of Australian red meat to consumers to be the product of choice. Developing a narrative for Australian provenance, verified by cost effective technologies will provide unique marketing opportunities to engage consumers in the experience of Australian red meat.

Products

Understanding insights into consumer behaviour presents opportunities for processors to develop new value-added products that consumers are willing to pay for. Integration of new product and process development systems will enable processors to move further down the supply chain. This allows for a greater realisation of margins and potential for volume growth.

Market Access

The focus is to increase market access for red meat through collaboration and co-investment in R&D programs and promotional activities which reduce economic and technical barriers to trade in global markets.

The Harris report (2017) delivered an insight into the myriad of non-economic trade barriers that the Australian red meat industry faces in export.

A systematic approach is required, as well as collaboration and prioritisation throughout the supply chain in order to eliminate the barriers that can be removed either by science or well-informed trade negotiations. AMPC will work with members to ensure that research into trade barriers is systematic, targeting both the biggest opportunities and the low hanging fruit, to ensure fairness in our international trade.

International Competitiveness

Australian red meat faces higher regulatory costs than its competitors which hinders the ability of Australia to be competitive in markets. With the world's highest regulatory burden in the international trade of red meat (Heilbron, 2018), technologies that can remove the cost involved with human interaction will be a focus for R&D.

MARKETING & PROMOTION

Objective

Doubling the value of the industry by 2030 in line with RMAC's Red Meat 2030 vision

Initiatives

- Development of domestic marketing and promotion projects with MLA
- Development of international marketing and promotion projects with MLA
- Provenance: Paddock to plate

PRODUCTS

Objectives

In 2025 the value of the Australian red meat industry will **increase by \$10m** based on New Product Development (NPD) delivering to consumer insights

By 2025 contribute to **reducing the red meat industry's overall costs** by \$5m and increase the value of the total sold products by 3%, through integrating new process technologies

Initiatives

- Consumer insights to identify 'gaps' for NPD opportunities
- New product development
- Co-product development
- New process development

MARKET ACCESS

Objectives

By 2025, deliver science-based equivalence cases that contribute to a **\$10m reduction** in non-tariff trade barriers for the red meat industry

Through evidence deliver a **20% increase** in access to negotiated trade markets (eg European Union) by 2025

Initiatives

- Technical trade barriers
- Non-technical trade barriers

INTERNATIONAL COMPETITIVENESS

Objectives

Through to 2025, verification costs for the processing sector will remain static by developing new verification technologies

By 2025, **costs of data monitoring and recording** will remain static by developing new measurement and data collection technologies

Initiatives

- Regulatory burden (cost of verification)
- Remote verification
- Pre-shipment clearance technologies
- Regulatory burden (cost of conducting)
- Visual inspection
- Automated data collection



STRATEGIC POLICY RESEARCH

Objectives

Minimise cost of regulation and compliance

Improve international competitiveness

Initiatives

- Develop insights to inform industry on new approaches to achieve modernisation priorities
- Research to inform policy on geopolitics and prioritisation of new markets
- Develop insight on environmental barriers to trade

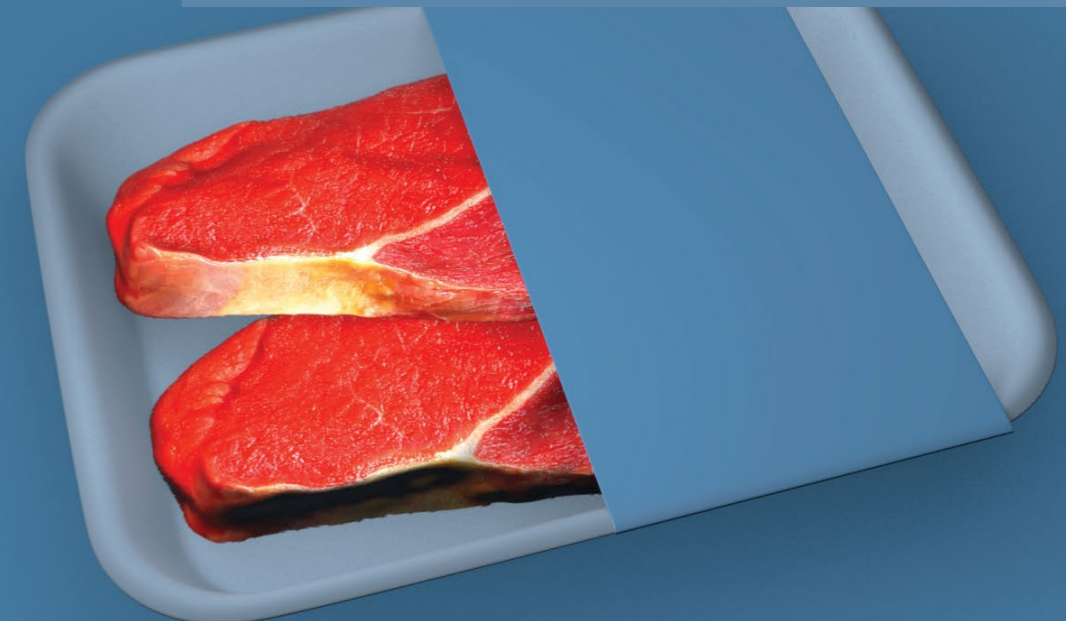

PRODUCT & PROCESS INTEGRITY

Program Aspiration

THE AUSTRALIAN RED MEAT INDUSTRY MAINTAINS AND FURTHER ENHANCES ITS INTERNATIONAL REPUTATION FOR SAFE, SUSTAINABLY-SOURCED, WHOLESOME RED MEAT PRODUCTS.



Domestic and international consumers trust Australian red meat credentials and globally it is recognised as both **the safest and of the best quality**.

That reputation is well-earned through the systems and processes which are in place across the industry. Processors play a unique, unseen role within the paddock-to-plate supply chain, ensuring the exacting standards of Australian red meat. To continue to earn that trust, the Australian red meat industry must exceed the expectations of its stakeholders and develop new ways to support market access by enhancing product integrity and technical research.

AMPC invests in research and development which is vital to maintaining the industry's reputation for safe, healthy products; and which ultimately adds value to red meat sales and processor profitability.

Traceability & Integrity Systems

Complete traceability along the entire meat supply chain has long been the target for the industry and is recognised as an opportunity to engage with consumer expectations and to add value. The development of an "all in" fully traceable production system has been elusive. The industry needs to break down the barriers to development and full adoption, as well as work on digitisation of processes within establishment to drive transparency and trust along the supply chain all the way to the consumer and back.

Animal Welfare

The whole of the red meat industry from paddock to plate, is accountable for upholding animal welfare standards. Stakeholders expect increasing levels of animal welfare standards to be upheld and openly demonstrated. There is still room for improvement in processes and adoption of standards which will further raise our world-class animal welfare credentials. Furthermore, the industry needs to be better co-ordinated in answering the challenge to ensure good animal welfare outcomes and increased transparency in engagements with stakeholders.

Development of integrity systems that can genuinely improve animal welfare outcomes and which can track provenance is an opportunity for the whole of industry to establish better relationships with stakeholders while adding value to product.

Food Safety

The Australian red meat industry has a well-earned reputation for producing safe, wholesome meat and meat products. It is important that continuous improvement is embedded in industry-wide food safety initiatives.

Further development of technologies to detect and eliminate contamination and other food safety issues will maintain the industry's reputation and potentially enhance opportunities for growth into high margin markets.

TRACEABILITY & INTEGRITY SYSTEMS

Objectives	Initiatives
Reduce risks to market access by providing real time information from producers and feedlots for processors through integrity systems , with the goal of full adoption through the supply chain by 2025	<ul style="list-style-type: none"> — Traceability paddock to plate — Traceability plate to paddock
By 2025, traceability and tracking systems integrated through the supply chain that will be able to provide traceability data for brand owners, regulators, and consumers from slaughter to carton	<ul style="list-style-type: none"> — Traceability paddock to plate — Traceability plate to paddock
By 2025, the red meat industry will be developing a data collection system to assist marketing and new product development initiatives	<ul style="list-style-type: none"> — Traceability paddock to plate — Traceability plate to paddock

STRATEGIC POLICY RESEARCH

Objective	Initiative
Consistent standards on labelling requirements	<ul style="list-style-type: none"> — Develop insights to inform an industry policy on a national standard for labelling



ANIMAL WELFARE

Objectives	Initiatives
By 2025, red meat processors will have a transparent, industry-owned national animal welfare standard that exceeds all other standards globally	<ul style="list-style-type: none"> — Stakeholder co-innovation — Guides and tools development
Engage community support for the red meat industry by communicating directly and transparently to interested stakeholders	<ul style="list-style-type: none"> — Stakeholder co-innovation — Guides and tools development

STRATEGIC POLICY RESEARCH

Objective	Initiative
Ensure industry maintains its social licence to operate	<ul style="list-style-type: none"> — Better understand stakeholder expectations of processors on animal welfare

FOOD SAFETY

Objective	Initiatives
In 2025 Australian red meat (regardless of breed) will be the go-to premium protein internationally and will deliver margin growth and higher returns for all processors	<ul style="list-style-type: none"> — Market access technical research — New detection and evaluation technologies

FINANCIALS

Over the next five years, more than \$200m will be invested into strategic programs of work, delivering significant value to processor levy payers.

The 2020-2025 Strategic Plan has taken a thorough approach to planning income and expenditure to deliver our programs. Built from the ground up, our allocation of resources is based on deep insights into the needs and priorities of the processing sector now and into the future. The attraction of co-funding contributions from the processing sector for the delivery of on-plant innovation initiatives will also bring a commercial edge to our programs and encourage genuine partnerships between AMPC and processing companies.

Target Reserves

AMPC has adopted a targeted reserves balance policy to ensure the balance at the end of the five year strategic period is in line with policy. The policy also ensures strategic investment decisions are made to maximise value to industry whilst ensuring sufficient funding is available for future commitments. The target reserves balance for the 2020—2025 Strategic Plan is \$10m.

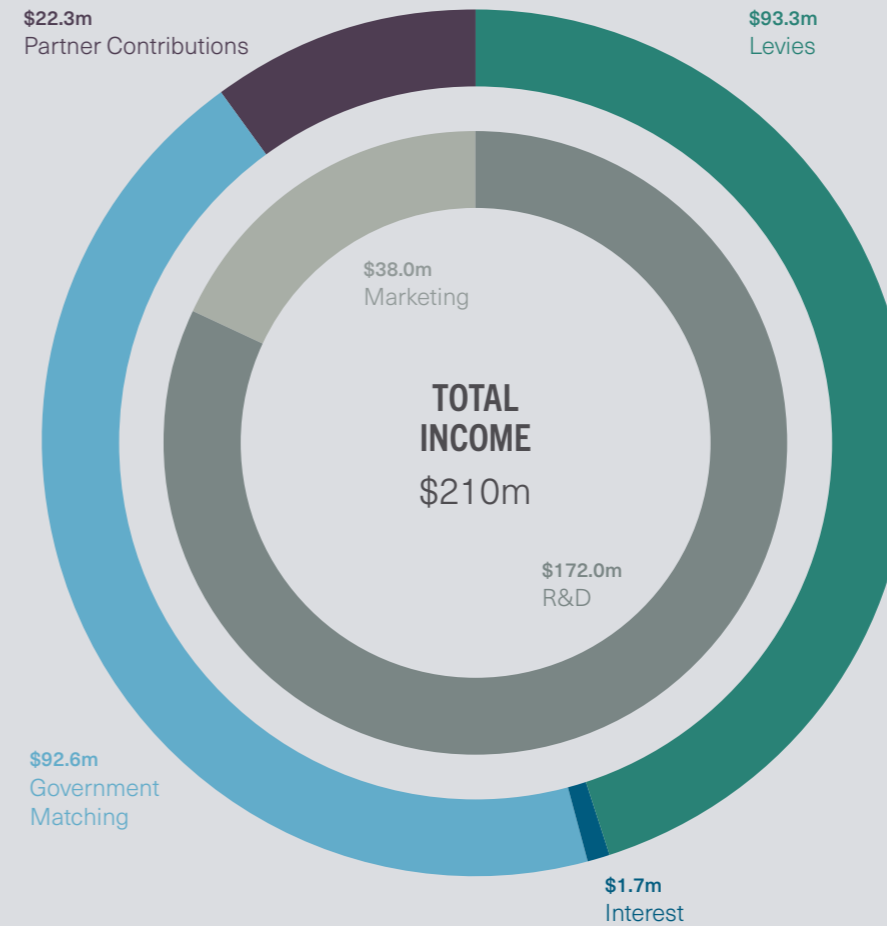
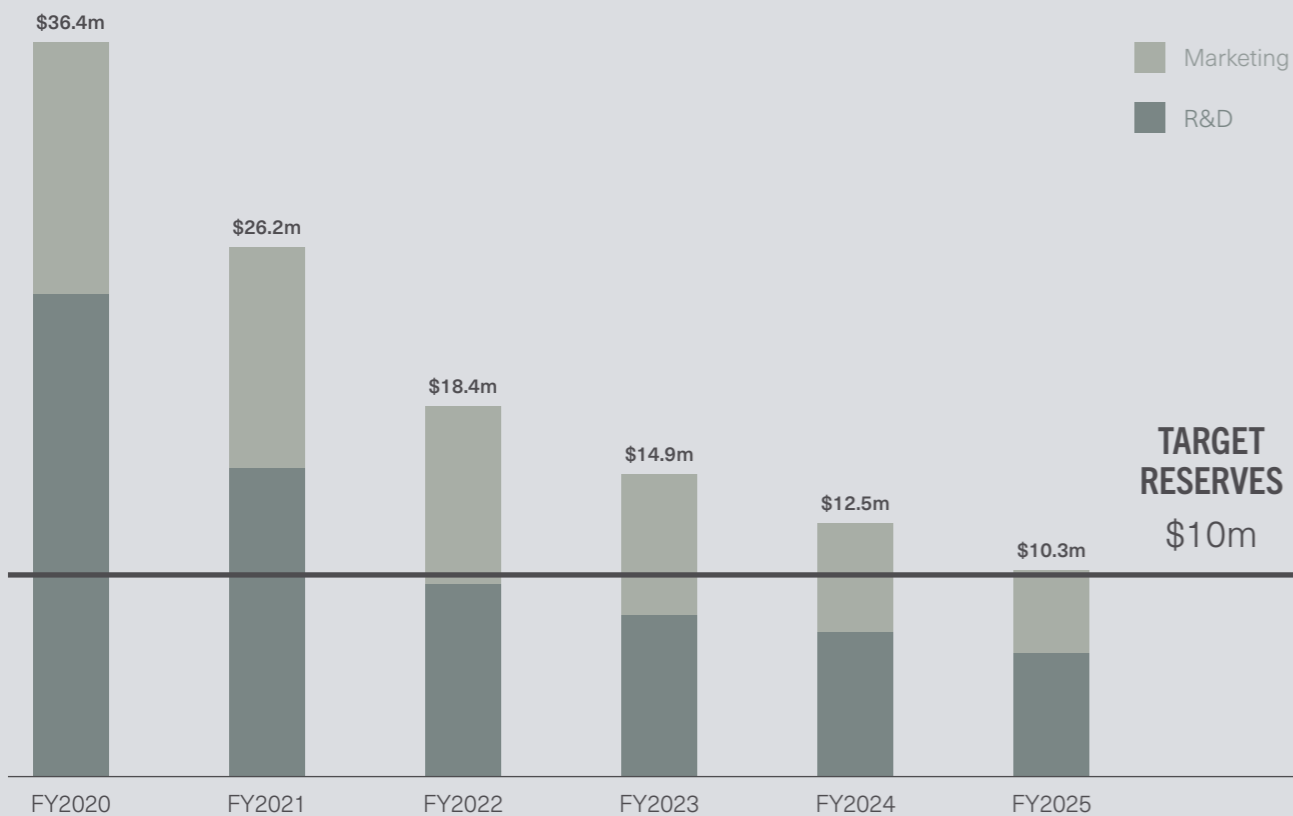

Income

Statutory levies continue to be the primary source of funding for AMPC, and economic modelling has been undertaken to estimate levy income over the strategic planning horizon. Considering current beef herd and ovine flock size, an anticipated recovery and restocking phase and other factors, an average levy income of \$18.7m per year is anticipated. In addition, processing industry contributions towards plant initiated projects is anticipated to be \$4.5m per year, bolstering our efforts to ensure on-plant participation and adoption. Finally, government matching on eligible R&D activities is anticipated to be an average of \$18.5m per year.

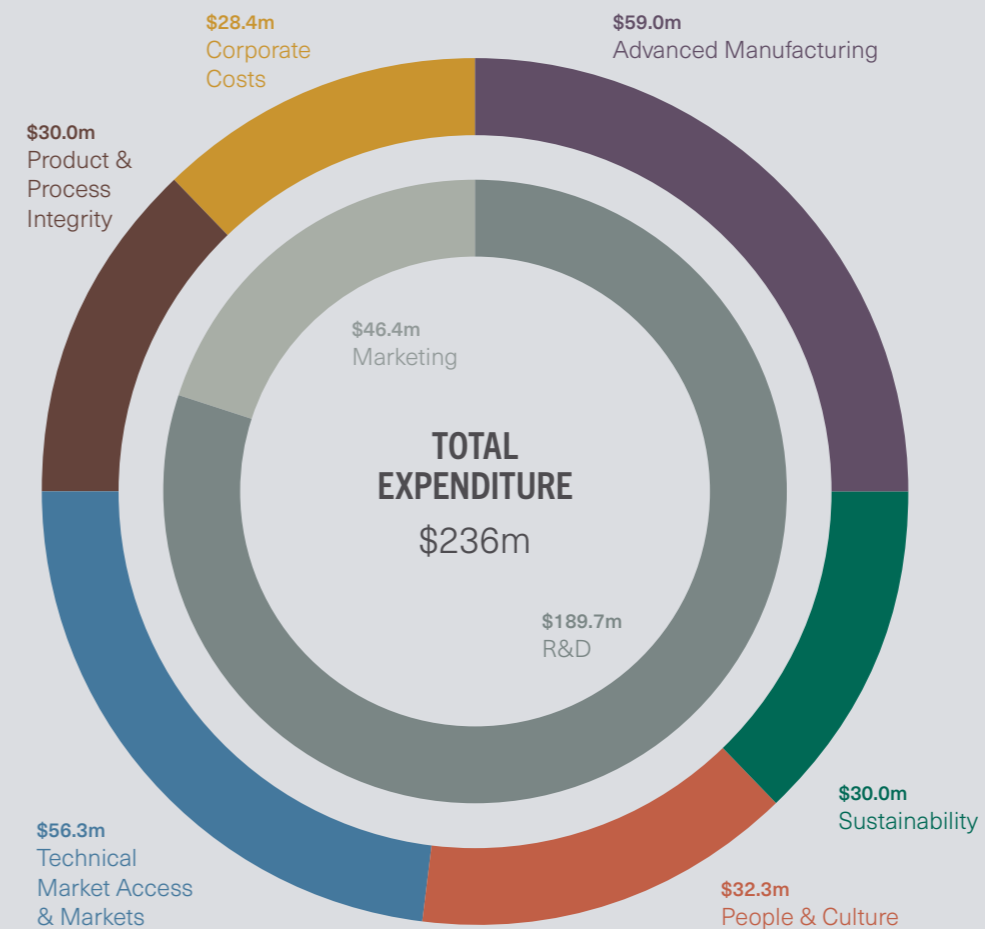

Expenditure

In developing the 2020-2025 Strategic Plan, a detailed program roadmap was developed, allowing for the allocation of resources to strategic programs over a five-year horizon. Over the next five years, the total amount allocated for investment into the five programs is \$207m. Of this, \$81m is allocated to core projects, \$89m is allocated to plant initiated projects, and \$37m is allocated for joint activities via Meat & Livestock Australia. Our investment into plant initiated projects seeks to balance the moderate-to-high risk industry-wide activities of our core projects with an involved, commercially-minded portfolio that delivers immediate and direct value to levy payers.

RESEARCH PRIORITIES

The AMPC Strategic Plan 2020-2025 supports the red meat industry's strategic plan, **Red Meat 2030**, and is aligned to the **National Science and Research Priorities** and the **Rural Research, Development and Extension Priorities**.





ADVANCED MANUFACTURING

FOCUS AREA	National Science & Research Priorities	Rural Research, Development & Extension Priorities	Red Meat 2030 Priorities
 Hands-off Processing	— Advanced Manufacturing	— Advanced Technology	— Our People
 Carcase Primal Profitability Optimisation	— Advanced Manufacturing	— Advanced Technology	
 Adoption	— Health	— Adoption of R&D	— Our People
 Digitisation	— Advanced Manufacturing	— Advanced Technology	— Our Systems





SUSTAINABILITY

FOCUS AREA	National Science & Research Priorities	Rural Research, Development & Extension Priorities	Red Meat 2030 Priorities
 Communities	— Health	— Soil, Water & Managing Natural Resources — Adoption of R&D	— Our Consumers, Customers & Community — Our Environment
 Water	— Soil & Water — Environmental Change — Health	— Soil, Water & Managing Natural Resources — Adoption of R&D	— Our Consumers, Customers & Community — Our Environment
 Waste	— Soil & Water — Environmental Change — Health	— Advanced Technology — Soil, Water & Managing Natural Resources — Adoption of R&D	— Our Consumers, Customers & Community — Our Environment
 Energy	— Transport — Energy — Environmental Change — Health	— Advanced Technology — Soil, Water & Managing Natural Resources — Adoption of R&D	— Our Consumers, Customers & Community — Our Environment
 Packaging	— Environmental Change — Health — Food	— Advanced Technology — Soil, Water & Managing Natural Resources — Adoption of R&D	— Our Consumers, Customers & Community — Our Environment



PEOPLE & CULTURE

FOCUS AREA	National Science & Research Priorities	Rural Research, Development & Extension Priorities	Red Meat 2030 Priorities
 Attraction	— Health	— Adoption of R&D	— Our People — Our Customers, Consumers & Community
 Development	— Health	— Adoption of R&D	— Our People — Our Customers, Consumers & Community
 Retention	— Health	— Adoption of R&D	— Our People — Our Customers, Consumers & Community
 Safety & Wellbeing	— Health	— Adoption of R&D	— Our People — Our Customers, Consumers & Community

TECHNICAL MARKET ACCESS & MARKETS

FOCUS AREA	National Science & Research Priorities	Rural Research, Development & Extension Priorities	Red Meat 2030 Priorities
 Marketing & Promotion	— Food — Health	— Biosecurity — Adoption of R&D	— Our Customers, Consumers & Community — Our Markets
 Products	— Food — Health — Advanced Manufacturing	— Biosecurity — Advanced Technology	— Our Customers, Consumers & Community — Our Markets
 Market Access	— Food — Health — Advanced Manufacturing — Transport	— Biosecurity — Advanced Technology	— Our Customers, Consumers & Community — Our Markets
 International Competitiveness	— Food — Health — Advanced Manufacturing — Transport	— Biosecurity — Advanced Technology	— Our Customers, Consumers & Community — Our Markets

PRODUCT & PROCESS INTEGRITY

FOCUS AREA	National Science & Research Priorities	Rural Research, Development & Extension Priorities	Red Meat 2030 Priorities
 Animal Welfare	<ul style="list-style-type: none"> — Advanced Manufacturing — Health 	<ul style="list-style-type: none"> — Biosecurity — Adoption of R&D 	<ul style="list-style-type: none"> — Our Livestock — Our Customers, Consumers & Community — Our Markets
 Traceability & Integrity Systems	<ul style="list-style-type: none"> — Food — Transport — Health — Environmental Change 	<ul style="list-style-type: none"> — Advanced Technology — Biosecurity — Adoption of R&D 	<ul style="list-style-type: none"> — Our Systems — Our Markets — Our Customers, Consumers & Community
 Food Safety	<ul style="list-style-type: none"> — Food — Advanced Manufacturing — Health 	<ul style="list-style-type: none"> — Advanced Technology — Biosecurity — Adoption of R&D 	<ul style="list-style-type: none"> — Our Systems — Our Markets — Our Customers, Consumers & Community

3D Models (covers)
 Courtesy of Strategic Engineering Pty Ltd

Disclaimer
 The Australian Meat Processor Corporation (AMPC), has developed this Strategic Plan for internal use only. In publishing this document, AMPC is engaged in disseminating information, not rendering professional advice or services. AMPC, its authors and editors expressly disclaim any form of liability to any person in respect of anything done or omitted to be done by such person in reliance upon the whole or any part of the contents of this document.

