

Packaged Pumping System

GRUNDFOS HYDRO MPC CME

The Grundfos Hydro MPC CME is a compact, reliable, and energy efficient packaged pumping system ideal for pressure boosting and HVAC applications in apartments, large homes, and multistory buildings.

The advanced Grundfos controls and MLE motor, in combination with variable speed multistage pumps, deliver unsurpassed system efficiency. This plug-and-pump system is easy to specify, install and will provide energy efficient and reliable operation for years.



KEY FEATURES AND BENEFITS

- **Single source responsibility** ensures one point of contact for all questions and service
- **Affordable packaged system** with the most advanced controller; offered in 2–3 pump configurations
- **Compact design** fits into tight spaces — through a 36" standard door — making it ideal for retrofits
- **Drinking water approvals** from UL Listed Packaged Pumping System and NSF 61/372 drinking water certified; plus ASHRAE 90.1 compliant

CU 352 CONTROLLER

- **Pump cascade control**, using efficiency-based sequencing, delivers the most efficient operation and protects pumps from running outside their duty range
- **SCADA communication capable** via Ethernet and all industry standard BUS protocols utilizing CIM expansion cards, with BACnet MSTP as standard
- **100kA SCCR fault current** rated panel
- **Built-in logging capability** records operational data such as system built-in performance, flow estimation and energy consumption for troubleshooting and energy analysis
- **Proportional pressure control** makes possible to simulate remote mounted sensor for simplified installation
- **Secondary (fallback) sensor** allows for system control from local sensor, with corresponding setpoint, if remote sensor fails
- **Check valve failure notification** warns or alarms, based on check valve leak rate
- **HVAC controls** includes differential pressure control from the two integrated sensors and multizone control for up to six zones

CME PUMP

- **Horizontal multistage pump** that is a compact, reliable and quiet solution
- **Materials of Construction:** cast iron (ASTM A48), stainless steel (AISI 304 and AISI 316)

MLE MOTOR

- **Grundfos Permanent Magnet MLE motors'** offer significant energy savings over NEMA Premium motors with conventional VFD's
- **Built-in protection** against power supply interruptions, along with environment and motor load
- **Innovative design mitigates** against bearing currents

MANIFOLDS

- **316 stainless steel manifolds** are engineered to reduce pressure loss and protect against corrosion

APPLICATIONS

- Pressure Boosting
- Hydronic Heating and Cooling

TECHNICAL DATA

| HYDRO MPC CME | |
|-----------------------------|--|
| FLOW, Q (2–3 PUMPS): | max. 345 gpm (78.36 m ³ /h) |
| HEAD, H: | max. 230 ft (70 m) |
| WORKING PRESSURE: | max. 145 psi (10 bar) |
| LIQUID TEMPERATURE: | <ul style="list-style-type: none"> • CME3-5: 32° F to 140° F (0° C to 60° C) • CME10-15: 32° F to 180° F (0° C to 82° C) |
| APPROVALS: | <ul style="list-style-type: none"> • System NSF 61/372 Certified • UL Listed Packaged Pumping System |

PERFORMANCE DATA

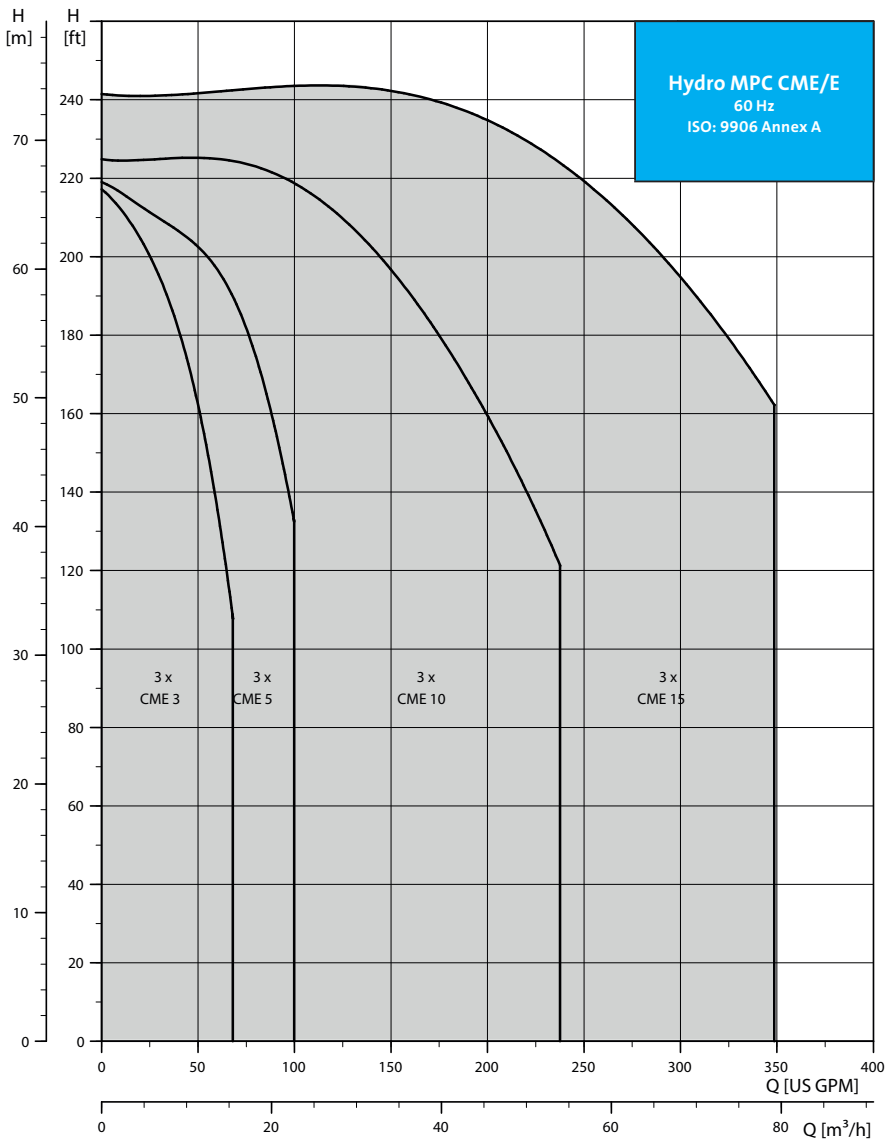

Trademarks displayed in this material, including but not limited to Grundfos, the Grundfos logo and "be think innovate" are registered trademarks owned by The Grundfos Group. All rights reserved. © 2019 Grundfos Holding A/S, all rights reserved. LBRQ-SL-06 08-19

Pump Performance Datasheet

| | |
|--|---|
| Customer : | Quote Number / ID : 1561369 |
| Customer ref. / PO : | Model : Hydro MPC 3CME 15-1 3x460V 60Hz |
| Tag Number : Hydro MPC 3CME 15-1 3x460V 60Hz | Part Number : 99659088 |
| Service : | Stages : 1 |
| Quantity : 1 | Based on curve number : 99329897 |
| Quantity of pumps : 3 active + 0 standby | Date last saved : 12/27/2021 9:27 PM |

| Operating Conditions | | Liquid | |
|---|---------------------|-------------------------------|--|
| System flowrate | : 276.1 USgpm | Liquid type | : Cold Water |
| Flowrate per pump | : 92.03 USgpm | Additional liquid description | : |
| Differential head / pressure, rated (requested) | : 69.63 ft | Temperature, max | : 68.00 deg F |
| Differential head / pressure, rated (actual) | : 69.63 ft | Fluid density, rated / max | : 1.000 / 1.000 SG |
| Suction pressure, min / max | : 0.00 / 0.00 psi.g | Viscosity, rated | : 1.00 cP |
| NPSH available, rated | : Ample | Vapor pressure, rated | : 0.34 psi.a |
| Site Supply Frequency | : 60 Hz | | |
| Power Supply | : 3ph 460V | Material | |
| | | Material selected | : Standard - Cast Iron / 304 Stainless Steel |

| Performance | | Pressure Data | |
|--|-----------------------------|------------------------------------|---------------------------------|
| Speed, rated | : 3599 rpm | Pump shut off pressure | : 38.14 psi.g |
| Speed, maximum | : 3599 rpm | Maximum allowable suction pressure | : 109.0 psi.g |
| Speed, minimum | : 764 rpm | | |
| Pump efficiency | : 68.67 % | Driver & Power Data (@Max density) | |
| NPSH required / margin required | : 20.70 / 0.00 ft | Motor sizing specification | : Max power (non-overloading) |
| nq (imp. eye flow) / S (imp. eye flow) | : 26 / 70 Metric units | Margin over specification | : 0.00 % |
| Head maximum, rated speed | : 88.13 ft | Service factor | : 1.15 |
| Head rise to shutoff | : 26.57 % | Rated power (based on duty point) | : 3 x 2.36 hp |
| Flow, best eff. point | : 88.96 USgpm | Max power (non-overloading) | : 3 x 2.50 hp |
| Flow ratio, rated / BEP | : 103.45 % | Motor rating | : 3 x 3.00 hp / 2.24 kW (Fixed) |
| Speed ratio (rated / max) | : 100.00 % | | |
| Head ratio (rated speed / max speed) | : 100.00 % | | |
| Cq/Ch/Ce/Cn [ANSI/HI 9.6.7-2010] | : 1.00 / 1.00 / 1.00 / 1.00 | | |
| Selection status | : Acceptable | | |

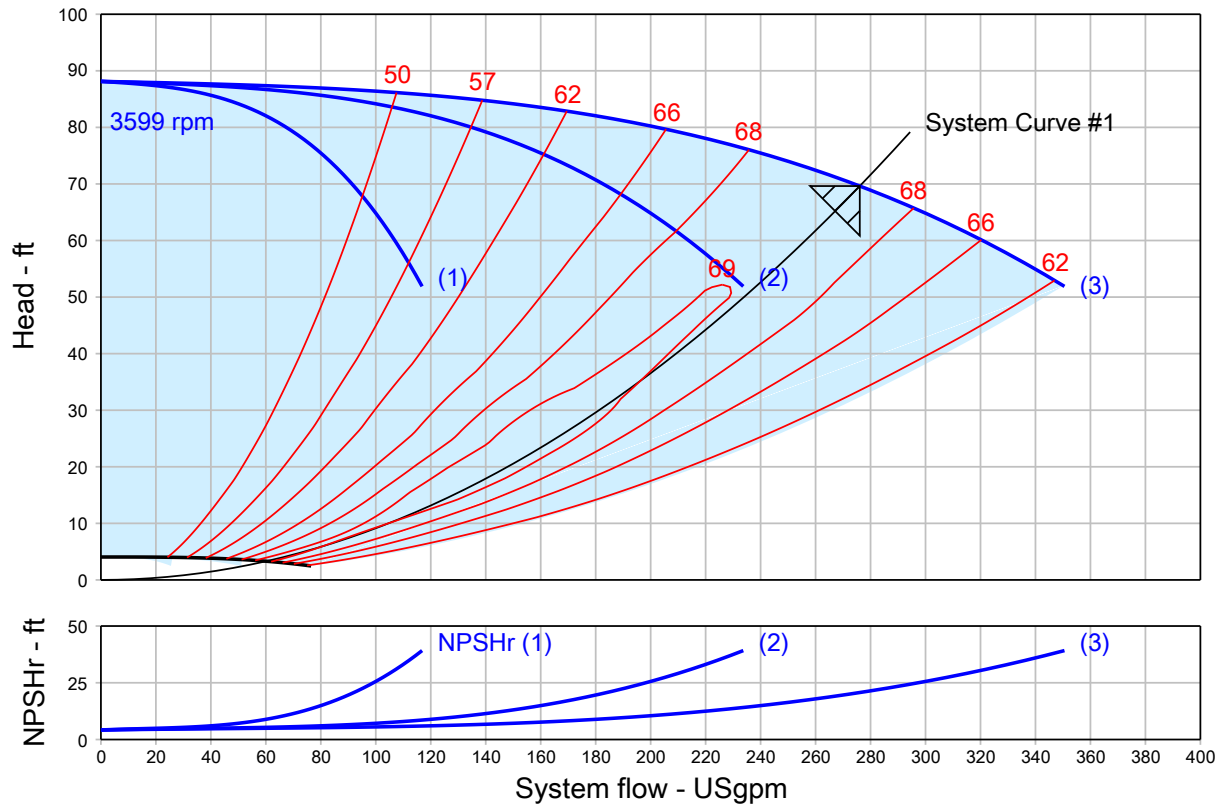

Hydro MPC E with CME pumps

| | | |
|----------------------------------|--|-------------------|
| QUOTE NUMBER / ID 1561369 | UNIT TAG Hydro MPC 3CME 15-1 3x460V 60Hz | QUANTITY 1 |
| REPRESENTATIVE | SERVICE | DATE |
| ENGINEER | SUBMITTED BY | DATE |
| CONTRACTOR | APPROVED BY | DATE |
| | ORDER # | |



**Hydro MPC 3CME
15-1 3x460V 60Hz
3480 rpm**

Part Number 99659088

| Conditions of Service | | Pump Data | | Motor Data | |
|-----------------------|-------------|--------------------------------|--|------------|-----------|
| Flow | 92.03 USgpm | Material | Standard - Cast Iron / 304 Stainless Steel | Motor HP | 3 HP |
| Head | 69.63 ft | Pump shut off pressure | 38.14 psi.g | BHP | 2.36 HP |
| Liquid | Cold Water | Max Allowable Suction Pressure | 109.0 psi.g | Enclosure | TEFC |
| Temperature | 68.00 deg F | Efficiency | 68.67 % | Voltage | 440-480 V |
| NPSHr | 20.70 ft | | | Phase | 3 Phase |
| Viscosity | 1.00 cP | | | | |
| Specific Gravity | 1.000 SG | | | | |

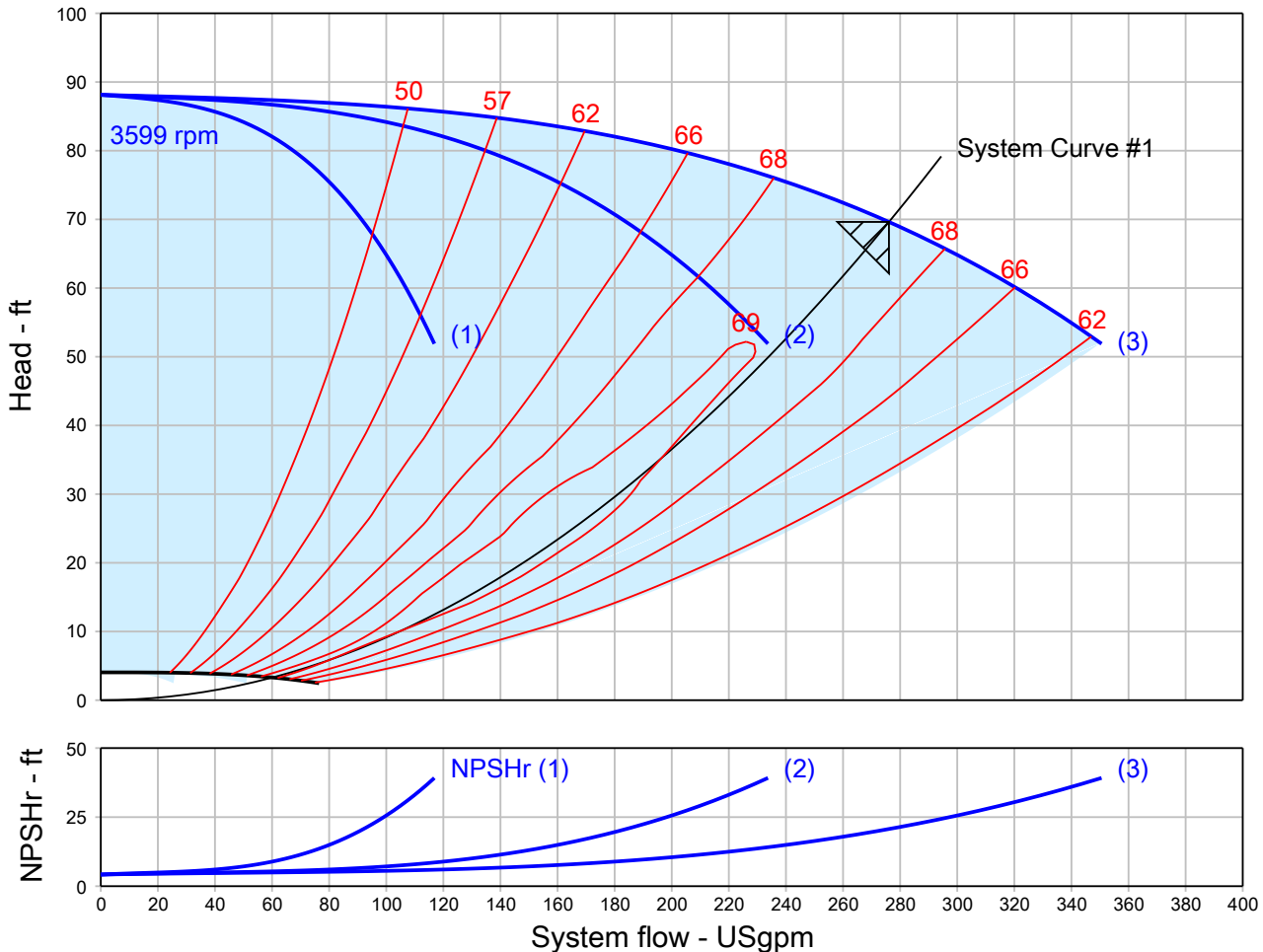

Pump Performance Curve

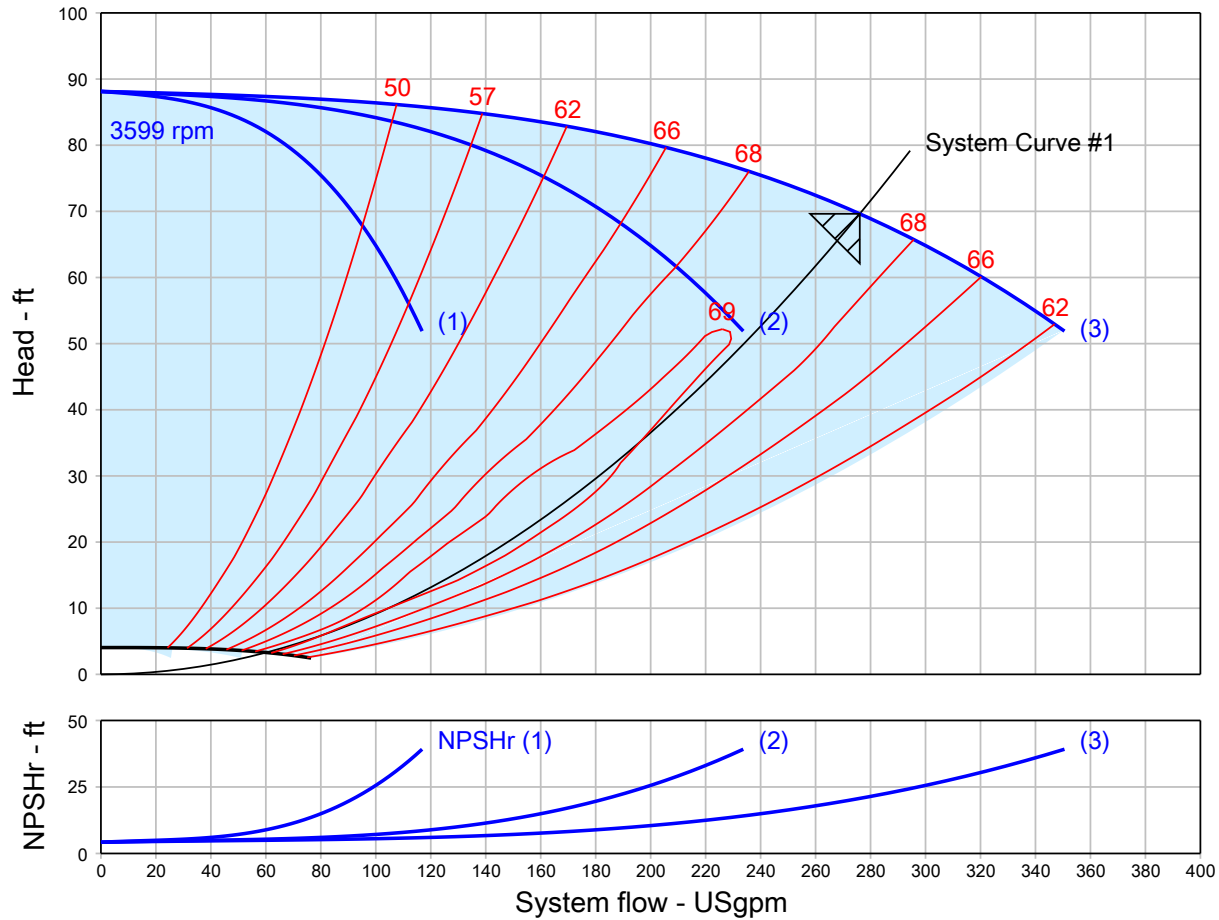

| | | | |
|-------------------------------------|-----------------------------------|-----------------------------------|------------------------------|
| Customer | : | Model | : Hydro MPC 3CME 15-1 3x460V |
| Customer ref. / PO | : | | 60Hz |
| Tag Number | : Hydro MPC 3CME 15-1 3x460V 60Hz | Stages | : 1 |
| Service | : | Speed, rated | : 3599 rpm |
| Quantity | : 1 | Based on curve number | : 99329897 |
| Quote Number / ID | : 1561369 | Pump efficiency | : 68.67 % |
| Date last saved | : 12/27/2021 9:27 PM | Rated power (based on duty point) | : 3 x 2.36 hp |
| System flowrate | : 276.1 USgpm | NPSH required | : 20.70 ft |
| Flowrate per pump | : 92.03 USgpm | Fluid density, rated / max | : 1.000 / 1.000 SG |
| Differential head / pressure, rated | : 69.63 ft | Viscosity | : 1.00 cP |
| Pressure control curve | : None | | |

Pump Performance Curve

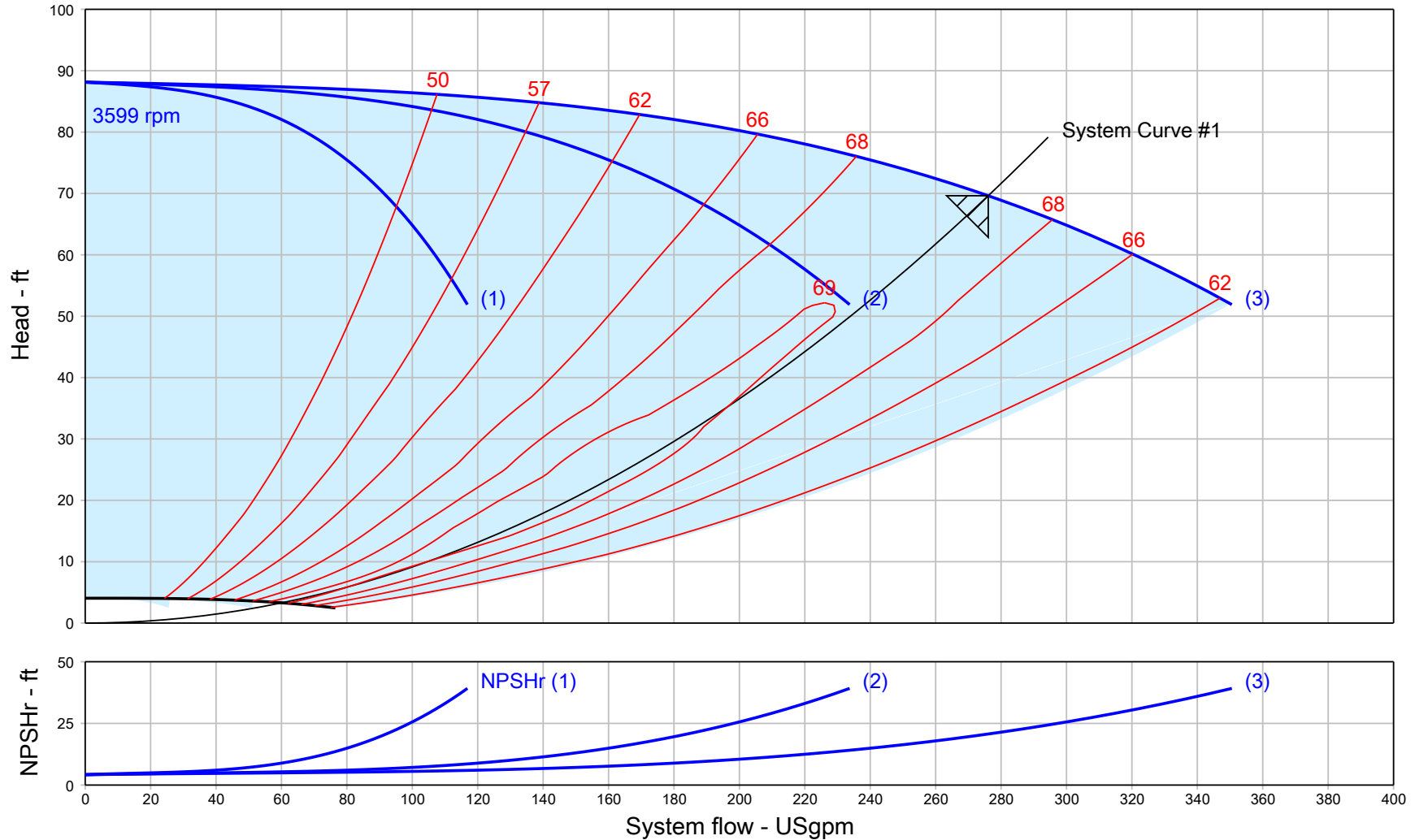

| | | | | | |
|------------------------|----------------------|----------------------------|------------------------------|-------------------------------------|---------------|
| Project name | : gogrundfos.com | Tag Number | : Hydro MPC 3CME 15-1 | Speed, rated | : 3599 rpm |
| Consulting engineer | : | | : 3x460V 60Hz | System flowrate | : 276.1 USgpm |
| Customer | : | Service | : | Flowrate per pump | : 92.03 USgpm |
| Customer ref. / PO | : | Model | : Hydro MPC 3CME 15-1 | Differential head / pressure, rated | : 69.63 ft |
| Quote Number / ID | : 1561369 | | : 3x460V 60Hz | Rated power (based on duty point) | : 3 x 2.36 hp |
| Date last saved | : 12/27/2021 9:27 PM | Quantity | : 1 | Max power (non-overloading) | : 3 x 2.50 hp |
| Pressure control curve | : None | Quoted By (Sales Office) | : HURLEY ENGINEERING COMPANY | Pump efficiency | : 68.67 % |
| | | Quoted By (Sales Engineer) | : Devin Carle | Based on curve number | : 99329897 |

Multi-Speed Performance Curve

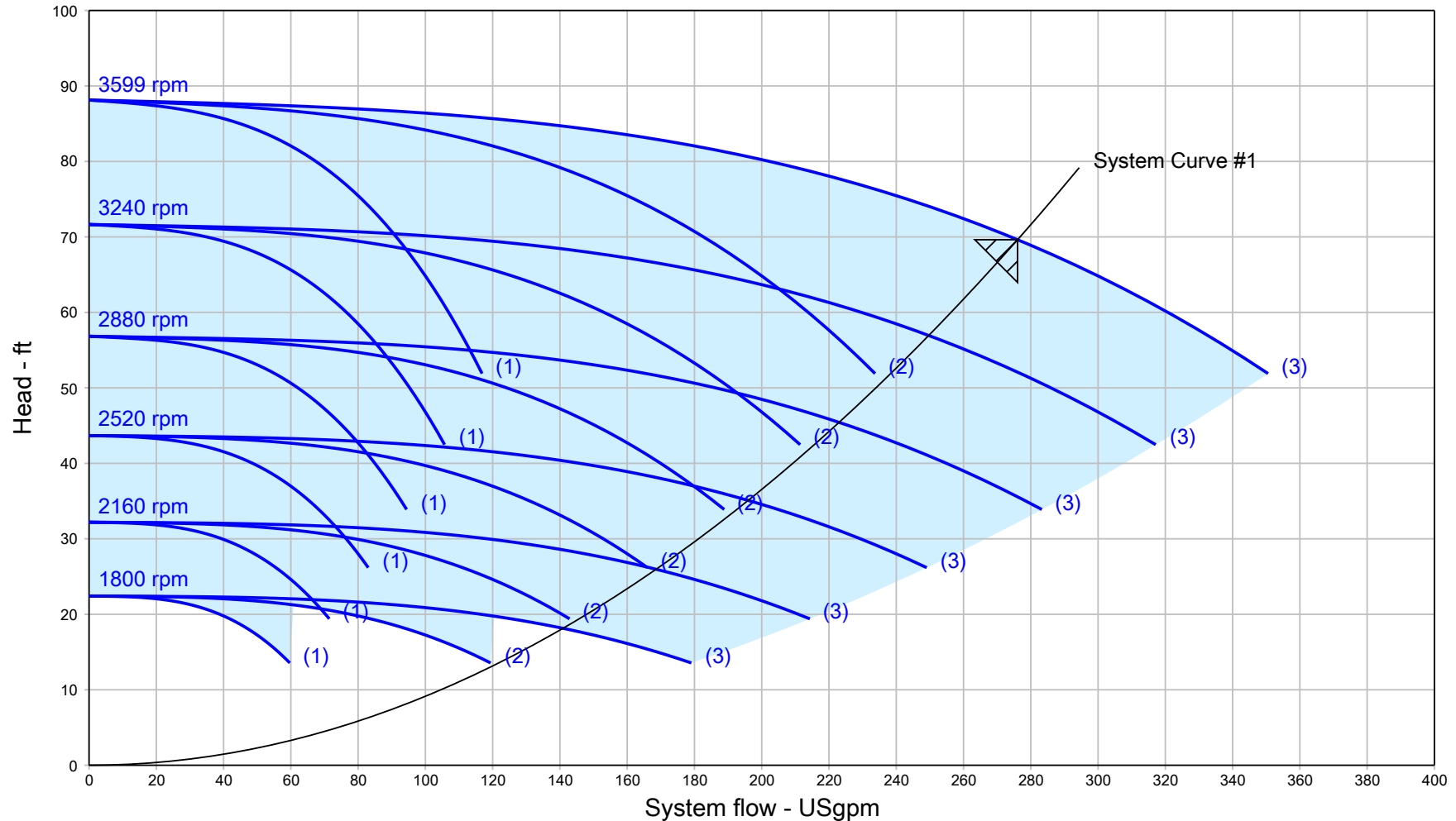

| | | | | | |
|------------------------|----------------------|----------------------------|--------------------------------------|-------------------------------------|--------------------|
| Project name | : gogrundfos.com | Tag Number | : Hydro MPC 3CME 15-1 3x460V 60Hz | Speed, rated | : 3599 rpm |
| Consulting engineer | : | Service | : | System flowrate | : 276.1 USgpm |
| Customer | : | Model | : Hydro MPC 3CME 15-1 3x460V 60Hz | Flowrate per pump | : 92.03 USgpm |
| Customer ref. / PO | : | Quantity | : 1 | Differential head / pressure, rated | : 69.63 ft |
| Quote Number / ID | : 1561369 | Quoted By (Sales Office) | : HURLEY ENGINEERING COMPANY | Fluid density, rated / max | : 1.000 / 1.000 SG |
| Date last saved | : 12/27/2021 9:27 PM | Quoted By (Sales Engineer) | : Devin Carle | Viscosity | : 1.00 cP |
| Pressure control curve | : None | | | Based on curve number | : 99329897 |

1. Manifolds 4" ANSI Class 150 AISI 316SS Schedule 10s ASTM A312 or \varnothing 114.3mm x2mm
2. Base/Frame AISI 304SS
3. Full port ball valve ASTM
4. UL Type 3R/12 rated electrical panel

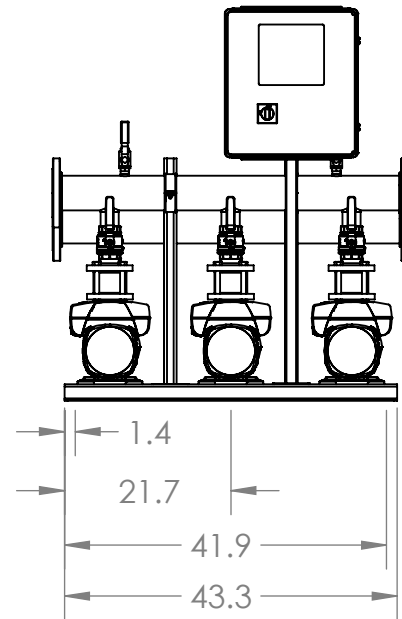
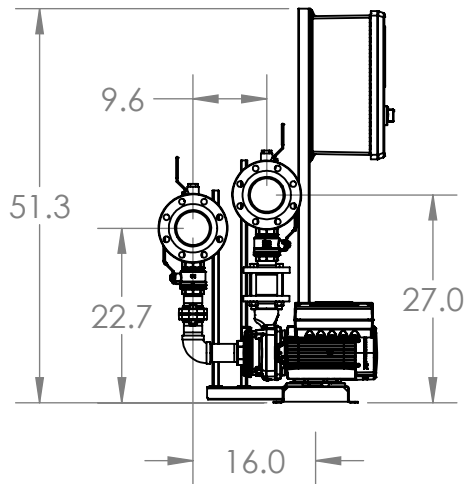
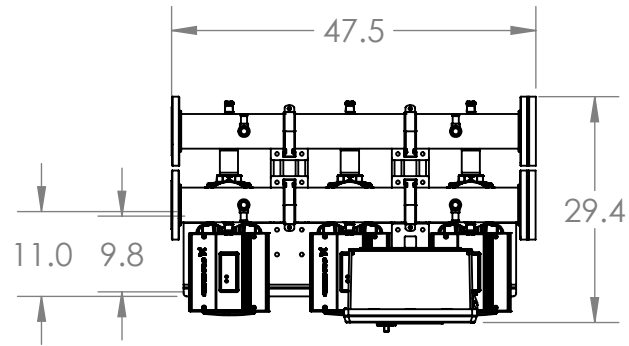
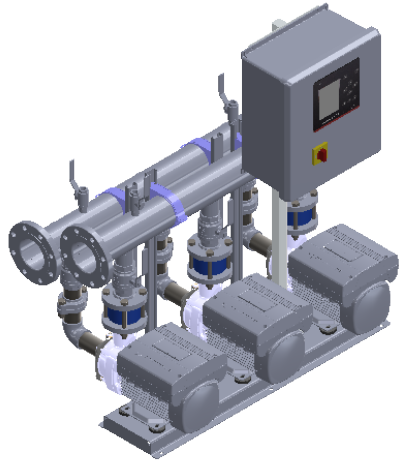

GRUNDFOS 
 FRESNO, CALIFORNIA 93727 USA

Note:
 All dimensions are $\pm 0.5"$
 Not for Construction
 All dimensions subject to
 changewithout notice.

BoosterpaQ Model: HYDRO MPC E 3CME15-1

Power: 3x460 60HZ 3x3HP

Job:

Scale: 1:25

Dwg No:

Rev: 0

Date:

6/20/2019

Drawer

71999

Page:

1 of 1

Ball Valves



General

- Threaded Ends
- Blow Out Proof Stem
- 600 WOG
- 2-Piece Body
- Teflon Seats
- Teflon Packing

Dimensions & Weights

| Size | DN (in) | S (in) | H (in) | L (in) | WT. (lb) |
|--------|---------|--------|--------|--------|----------|
| 1/4" | 0.39 | 1.76 | 1.75 | 3.54 | 0.35 |
| 3/4" | 0.75 | 2.50 | 2.18 | 3.94 | 0.79 |
| 1-1/4" | 1.26 | 3.42 | 2.87 | 4.80 | 1.75 |
| 1-1/2" | 1.57 | 3.76 | 3.48 | 5.91 | 2.47 |
| 2" | 1.97 | 4.25 | 3.82 | 5.91 | 3.46 |

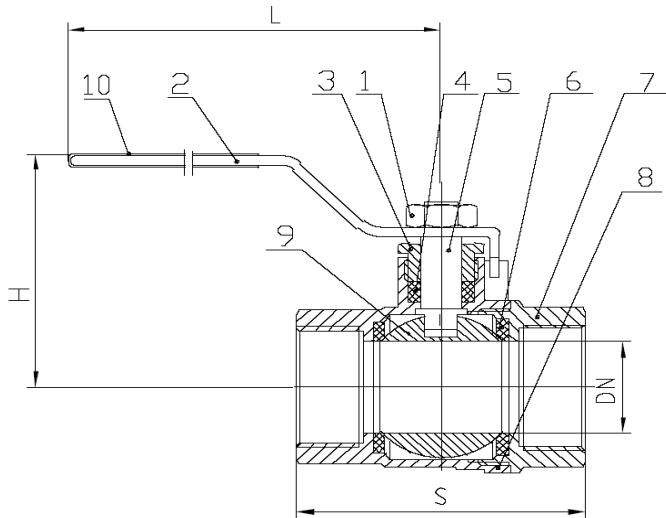

MATERIAL SPECIFICATIONS

| NO. PART | MATERIAL (ASTM) |
|-------------|--------------------------|
| 1 NUT | ZINC PLATED STEEL |
| 2 HANDLE | ZINC PLATED STEEL |
| 3 BONNET | BRASS (C37000) |
| 4 PACKING | TEFLON |
| 5 STEM | BRASS (C37000) |
| 6 BALL SEAT | TEFLON |
| 7 END PIECE | LOW LEAD BRASS (LTN60-6) |
| 8 BODY | LOW LEAD BRASS (LTN60-6) |
| 9 BALL | LOW LEAD BRASS (LTN60-6) |
| 10 SLEEVE | PVC |

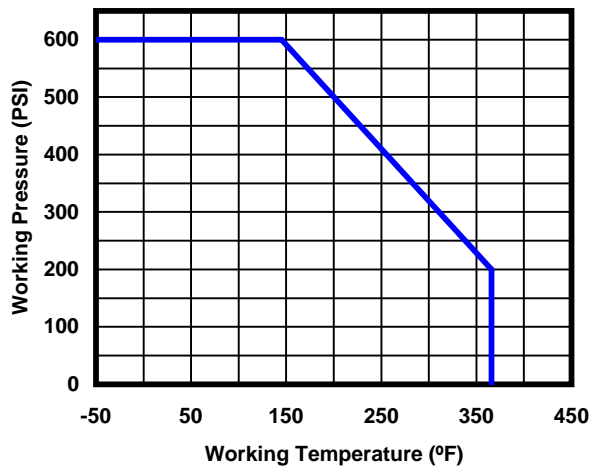

APPROVALS

- NSF 61, IAPMO - N4359
- AB1953, IAPMO - 5653



1. Non-return valves, type GNVP



Fig. 1 GNVP valves

GNVP non-return valves are designed for installation in pipe systems between two DIN flanges. Thanks to their compact design, the GNVP valves are easy to install. All composite parts have a wide range of drinking water approvals, maintained at regular test intervals. According to the DIN EN 13959 standard, all GNVP non-return valves incorporate two test/drainage plugs for user-friendly usage.

Applications

The GNVP non-return valves are designed exclusively for installation in Grundfos booster systems where a one-way water flow is required.

Maximum operating pressure: 16 bar (PN 16).

Liquid temperature: 0 °C to +60 °C.

Drinking water approvals

KIWA no.: 26819 (Netherlands)

WRAS no.: 1710375 (Great Britain)

DVGW no.: NW-6312AT2526 (Germany)

ACS no.: 17 ACC NY 338 (France)

BELGAQUA no.: 10/16a/EA (Belgium)

Construction

The polyoxymethylene (POM) valve housing is equipped with one or several insert valve cartridges, depending on the size. GNVP DN 32, DN 40 and DN 50-I are equipped with one valve cartridge. GNVP DN 50, DN 65, DN 80 and DN 100 are equipped with several valve cartridges. The DN 50-I is a special version with a smaller seal diameter.

The valve cartridge components are made of POM, the seals are made of NBR, and the spring is made of stainless steel, for optimum functionality and reliability.

Head loss

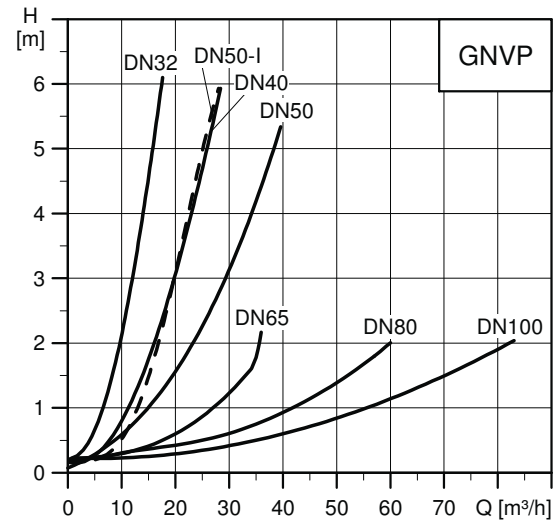
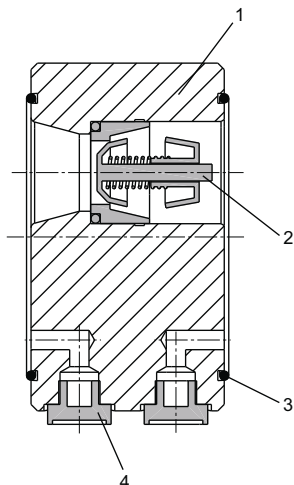

Fig. 2 Head loss curves for non-return valves, type GNVP

Dimensions

| Type | Outer diameter [mm] | Width [mm] | Size of O-ring seal [mm] | Product numbers |
|---------------------|---------------------|------------|--------------------------|-----------------|
| GNVP DN 32 (1 1/4") | 70 | 60 | Ø45 x 3 | 91040183 |
| GNVP DN 40 (1 1/2") | 90 | 60 | Ø56 x 3 | 91040184 |
| GNVP DN 50-I (2") | 108 | 60 | Ø76 x 3 | 96155179 |
| GNVP DN 50 (2") | 108 | 60 | Ø83 x 3 | 98595908 |
| GNVP DN 65 (2 1/2") | 125 | 60 | Ø94 x 3 | 91040186 |
| GNVP DN 80 (3") | 143 | 60 | Ø110 x 3 | 91069032 |
| GNVP DN 100 (4") | 160 | 60 | Ø130 x 3 | 91040187 |

Materials



TM04 9403 4417

Fig. 3 Components of a GNVP, DN 50 valve

Installation

| Pos. | Valve components | Materials |
|------|------------------|-----------------------|
| 1 | Housing | POM - Ultraform H4320 |
| 2 | Cartridge | POM - Hostaform/NBR |
| 3 | O-ring | EPDM |
| 4 | Plug | POM - Ultraform H4320 |
| | O-ring | EPDM |

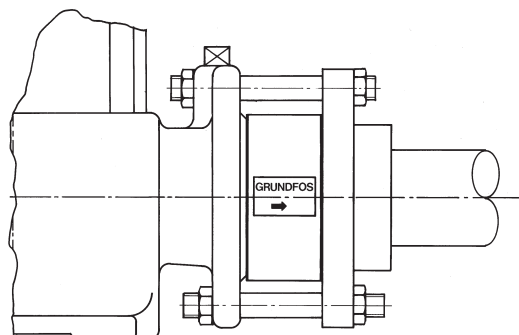

TM00 0551 3292

Fig. 4 Installation example, GNVP

The GNVP non-return valve is fitted between two DIN flanges, such as pump flange and counter flange, by means of bolts and nuts. The valve can be fitted in any position required. The arrow on the nameplate indicates the direction of the water flow.

Note: The GNVP valves have factory-fitted O-rings on both mating surfaces for optimum sealing against the flanges. As a result, no additional gaskets are required.

D80 Series

Dry or Liquid Filled • Stainless Steel Case

UTILITY GAUGES



D82LFB shown



- ▶ 1 1/2", 2", 2 1/2", 4" Dial Sizes
- ▶ ±1.6% Accuracy (1% Optional)
- ▶ Stainless Steel Case
- ▶ Glycerine Fill Standard

Specifications

| Models | | Wetted Parts |
|---------------------|--|---|
| D82B | (dry) | Bronze tube, brass socket |
| D82LFB | (liquid filled) | Lead-Free (PBF) Meets NSF/ANSI Standards 372 and 61 |
| D83SS | (dry) | 316 Stainless steel tube & socket |
| D83LFSS | (liquid filled) | |
| Dial Sizes | 1 1/2", 2", 2 1/2", 4" | |
| Fill | Glycerine, other fills available See Optional Features Section | |
| Movement | D82: Brass D83: 316 Stainless steel | |
| Connection | Lower male or center back male, (Lower back male 4" Dial only) | |
| Case | 304 stainless steel, stem-mounted flangeless | |
| Ring | Crimped 304 stainless steel | |
| Window | Acrylic | |
| Pointer | Plain, black finished | |
| Dial Face | Aluminum, white background with black graduations and markings | |
| Accuracy | ±1.6% Full Scale (1% available as an option) | |
| Maximum Temperature | 150°F (65°C) | |

Approximate Shipping Weight

| | |
|-------------------|-------------------|
| 1 1/2" Dial Size: | 0.4 lbs [0.18 kg] |
| 2" Dial Size: | 0.4 lbs [0.18 kg] |
| 2 1/2" Dial Size: | 0.5 lbs [0.23 kg] |
| 4" Dial Size: | 1.0 lbs [0.45 kg] |

The Trerice **D80 Series** Industrial Gauge is designed for rugged performance requirements at an economical cost. This liquid filled gauge is furnished with a stainless steel case and crimped ring. Wetted parts are either bronze tube with Lead-Free (PBF) brass socket or stainless steel.

- Optional features and case style variations available: Please consult the Options & Accessories Section for details.
- For correct use and application of all pressure gauges, please refer to: Pressure Gauge Standard ASME B40.100.

HOW TO ORDER

Sample Order Number: **D82LFB 25 02 L A 110**

| Model | Dial Size | Connection Size | Connection Location | Units of Measure | Range Code |
|---------|-----------|-----------------|---------------------|------------------|---------------------|
| D82LFB | 15 1 1/2" | 01 1/8 NPT* | L Lower | A psi | See Standard Ranges |
| D83LFSS | 20 2" | 02 1/4 NPT** | B Back | D psi/kPa | |
| D82B | 25 2 1/2" | 04 1/2 NPT*** | | | |
| D83SS | 40 4" | | | | |

* 1/8 NPT connection size not available with 4" dial size.
 ** 1/4 NPT connection size not available with 1 1/2" dial size.
 *** 1/2 NPT connection size only available with 4" dial size.

D80 Series

Dry or Liquid Filled • Stainless Steel Case

All dimensions are nominal. Dimensions in [] are in millimeters.

UTILITY GAUGES

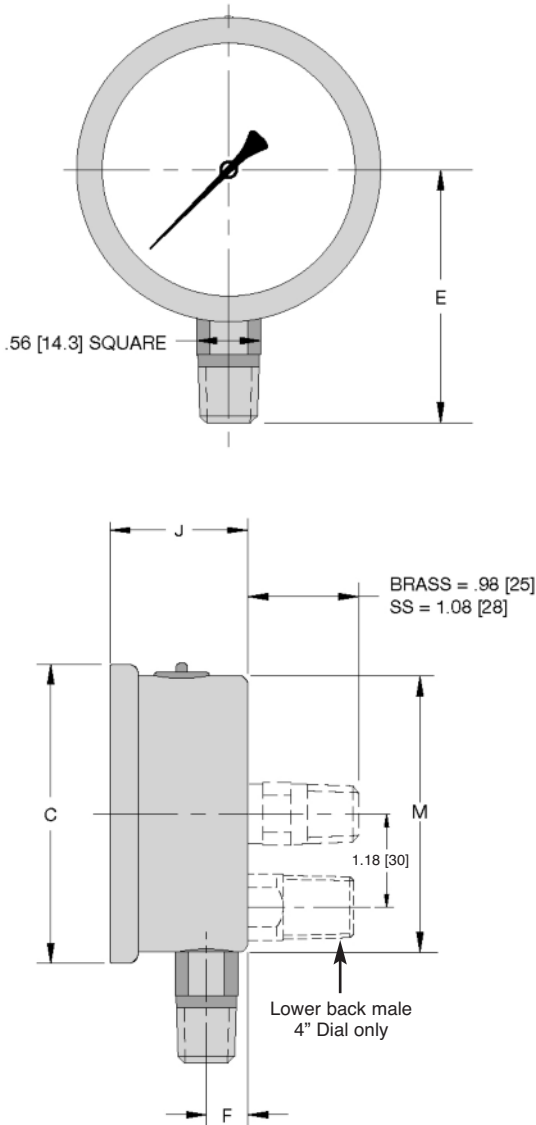

Standard Ranges

| psi Ranges (A) | | D82 | | D83 | |
|----------------|----------------------|------------------|-----------------|------------------|-----------------|
| Range Code | Specific Range (psi) | Figure Intervals | Minor Divisions | Figure Intervals | Minor Divisions |
| 010 | 30" Hg to 0 | 5 | 0.5 | 5 | 0.5 |
| 020 | 30" Hg to 15 psi | 10/5 | 1/0.5 | 10/5 | 1/0.5 |
| 030 | 30" Hg to 30 psi | 10/5 | 1/1 | 10/5 | 1/1 |
| 040 | 30" Hg to 60 psi | 10/10 | 2/1 | 10/10 | 2/1 |
| 050 | 30" Hg to 100 psi | 30/20 | 2/2 | 30/20 | 2/2 |
| 060 | 30" Hg to 150 psi | 30/30 | 5/2 | 30/30 | 5/2 |
| 070 | 30" Hg to 300 psi | 30/50 | 5/5 | 30/50 | 5/5 |
| 080 | 0 to 15 psi | 3 | 0.2 | 3 | 0.2 |
| 090 | 0 to 30 psi | 5 | 0.5 | 5 | 0.5 |
| 100 | 0 to 60 psi | 10 | 1 | 10 | 1 |
| 110 | 0 to 100 psi | 10 | 1 | 10 | 1 |
| 120 | 0 to 160 psi | 20 | 2 | 20 | 2 |
| 130 | 0 to 200 psi | 20 | 2 | 20 | 2 |
| 140 | 0 to 300 psi | 50 | 5 | 50 | 5 |
| 150 | 0 to 400 psi | 50 | 5 | 50 | 5 |
| 160 | 0 to 600 psi | 100 | 10 | 100 | 10 |
| 180 | 0 to 1000 psi | 100 | 20 | 100 | 20 |
| 190 | 0 to 1500 psi | 300 | 20 | 300 | 20 |
| 200 | 0 to 2000 psi | 200 | 20 | 200 | 20 |
| 210 | 0 to 3000 psi | 500 | 50 | 500 | 50 |
| 220 | 0 to 5000 psi | 1000 | 100 | 1000 | 100 |

Ranges over 5000 PSI are not available on D82LFB.

| | | | | | |
|-----|----------------|-----|-----|------|-----|
| 230 | 0 to 10000 psi | N/A | N/A | 2000 | 200 |
| 240 | 0 to 15000 psi | N/A | N/A | 3000 | 200 |

For dual scale ranges specify the appropriate **Units of Measure: D** (psi/kPa) followed by the corresponding **A** (psi) **Range Code**

| Dial Size | C | E | F | J | M |
|------------|------------|------------|-----------|-----------|------------|
| 1 1/2" D82 | 1.85 [47] | 1.50 [38] | 0.32 [8] | 1.06 [27] | 1.61 [41] |
| 1 1/2" D83 | 1.85 [47] | 1.50 [38] | 0.32 [8] | 1.06 [27] | 1.61 [41] |
| 2" D82 | 2.28 [58] | 1.89 [48] | 0.39 [10] | 1.14 [29] | 2.05 [52] |
| 2" D83 | 2.28 [58] | 2.05 [52] | 0.35 [9] | 1.18 [30] | 2.05 [52] |
| 2 1/2" D82 | 2.68 [68] | 2.24 [57] | 0.39 [10] | 1.18 [30] | 2.44 [62] |
| 2 1/2" D83 | 2.68 [68] | 2.32 [59] | 0.51 [13] | 1.38 [35] | 2.44 [62] |
| 4" D82 | 4.29 [109] | 3.07 [78] | 0.47 [12] | 1.42 [36] | 3.90 [99] |
| 4" D83 | 4.29 [109] | 3.94 [100] | 0.75 [19] | 1.93 [49] | 3.94 [100] |

Data sheet

MBS 3000 pressure transmitter for industrial applications

Introduction



- Designed for use in severe industrial environments
- Enclosure and wetted parts of acid-resistant stainless steel (AISI 316L)
- All standard output signals: 4-20 mA, 0-5 V, 1-5 V, 1-6 V, 0-10 V
- A wide range of pressure and electrical connections
- Temperature compensated and laser calibrated
- Typical applications:
 - Pumps
 - Compressors
 - Pneumatics
 - Water treatment

Dimensions

Ordering

| | | | | | | |
|---------------------|------------------------------------|----------------------------------|-----------------------------|---------------------------------------|-----------------|--------------------|
| Type code Page 4 | 8 | 2 | 5 | 7 | 1 | 3 |
| | AMP Superseal 1.5 series (male) | AMP Econoseal J series (male) | IEC 947-5-2 M12x1, 4-pin | ISO 15170-A1-3.2-Sn (Bayonet plug) | DIN 43650, Pg 9 | 2 m screened cable |

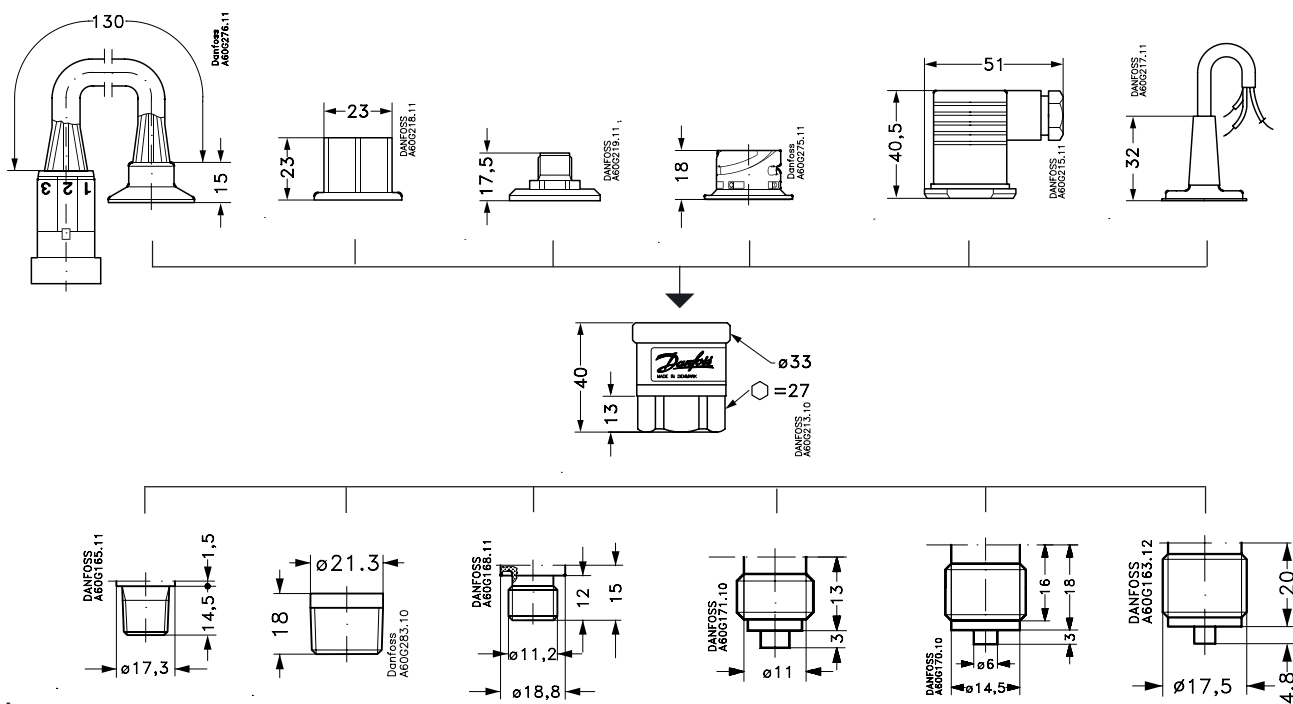

Ordering

| | | | | | | |
|---------------------|--------------|--------------|---|---------------------|---------------------|---------------------|
| | 1/4 - 18 NPT | 1/2 - 14 NPT | DIN 3852-E-G1/4 Gasket: DIN 3869-14 | G 1/4 A (EN 837) | G 3/8 A (EN 837) | G 1/2 A (EN 837) |
| Type code page 4 | AC04 | AC08 | GB04 | AB04 | AB06 | AB08 |

Technical data
Main specifications

| | | | | | | | | |
|------------------------|-------------|---------------|---------------|--------------|--------------|---------------|---------------|-------|
| Pressure connections | see page 1 | | | | | | | |
| Measuring ranges [bar] | 0-1 0-25 | 0-1.6 0-40 | 0-2.5 0-60 | 0-4 0-100 | 0-6 0-160 | 0-10 0-250 | 0-16 0-400 | 0-600 |
| Output signals | 4-20 mA | 0-5 V | 1-5 V | 1-6 V | 0-10 V | | | |
| Electrical connections | see page 3 | | | | | | | |

Performance (IEC 770)

| | |
|--|--|
| Accuracy | ±0.5% FS (typ.) ±1% FS (max.) |
| Non-linearity (best fit straight line) | ≤ ±0.5% FS |
| Hysteresis and repeatability | ≤ ±0.1% FS |
| Thermal zero point shift | ≤ ±0.1% FS/10K (typ.) ≤ ±0.2% FS/10K (max.) |
| Thermal sensitivity (span) shift | ≤ ±0.1% FS/10K (typ.) ≤ ±0.2% FS/10K (max.) |
| Response time | < 4 ms |
| Overload pressure | 6 × FS (max. 1500 bar) |
| Burst pressure | 6 × FS (max. 2000 bar) |
| Durability, P: 10-90% FS | >10×10 ⁶ cycles |

Electrical specifications

| | Nom. output signal (short-circuit protected) | | |
|--|--|------------------------|------------------------|
| | 4 – 20 mA | 0-5, 1-5, 1-6 V d.c. | 0-10 V d.c. |
| Supply voltage [U _B], polarity protected | 9 → 32 V d.c. | 9 → 30 V d.c. | 15 → 30 V d.c. |
| Supply - current consumption | - | ≤ 5 mA | ≤ 8 mA |
| Supply voltage dependency | ≤ ±0.05% FS/10 V | | |
| Current limitation (linear output up to 1.5x nom. range) | 34 mA (typ.) | - | |
| Output impedance | ≤ 25Ω | | |
| Load [R _L] (load connected to 0V) | R _L ≤ (U _B -9V)/0.02 | R _L ≥ 10 kΩ | R _L ≥ 15 kΩ |

Environmental conditions

| | | | | |
|--|-------------------------|-------------------------------------|--|--------------------------------|
| Medium temperature range | -40 → +85°C | | | |
| Ambient temperature range (depending on electrical connection) | see page 3 | | | |
| Compensated temperature range | 0 → +80°C | | | |
| Transport temperature range | -50 → +85°C | | | |
| EMC - Emission | EN 61000-6-3 | | | |
| EMC - Immunity | Electrostatic discharge | Air mode | 8 kV | EN 61000-6-2 |
| | | Contact mode | 4 kV | EN 61000-6-2 |
| | RF field | conducted | 10 V/m, 26 MHz - 1 GHz | EN 61000-6-2 |
| | | radiated | 10 V _{rms} , 150 kHz - 30 MHz | EN 61000-6-2 |
| | Transient | burst | 4 kV (CM), Clamp | EN 61000-6-2 |
| surge | | 1 kV (CM,DM), Rg = 42Ω | EN 61000-6-2 | |
| Insulation resistance | > 100 MΩ at 100 V d.c. | | | |
| Mains frequency test | 500 V, 50 Hz | | SEN 361503 | |
| Vibration stability | Sinusoidal | 15.9 mm-pp, 5Hz-25Hz | | IEC 60068-2-6 |
| | | 20 g, 25 Hz - 2 kHz | | |
| Shock resistance | Random | 7.5 g _{rms} , 5 Hz - 1 kHz | | IEC 60068-2-34, IEC 60068-2-36 |
| | Shock | 500 g / 1 ms | | |
| Enclosure (depending on electrical connection) | Shock | 500 g / 1 ms | | IEC 60068-2-27 |
| | Free fall | | | IEC 60068-2-32 |

Mechanical characteristics

| | | |
|---|------------------------|-------------------------------|
| Materials | Wetted parts | DIN 17440-1.4404 (AISI 316 L) |
| | Enclosure | DIN 17440-1.4404 (AISI 316 L) |
| | Electrical connections | see page 3 |
| Weight (depending on pressure connection and electrical connection) | 0.2-0.3 kg | |

Electrical connections

| Type code, page 4 | | | | | |
|--|---|--|---|---|--|
| 1 | 2 | 5 | 7 | 8 | 3 |
| DIN 43650, Pg 9 | AMP Econoseal J series (male) | IEC 947-5-2 M12x1 | ISO 15170-A1-3.2-Sn (Bayonet plug) | AMP Superseal 1.5 series (male) | 2 m screened cable |
| <i>Ambient temperature</i> | | | | | |
| -40 → + 85 °C | -40 → + 85 °C | -25 → +85 °C | -40 → +85 °C | -40 → +85 °C | -30 → +85 °C |
| <i>Enclosure</i> | | | | | |
| IP 65 | IP 67 | IP 67 | IP 67 / IP 69K | IP 67 | IP67 |
| <i>Materials</i> | | | | | |
| Glass filled polyamid, PA 6.6 | Glass filled polyamid, PA 6.6 ¹⁾ | Nickel plated brass, CuZn/Ni | Glass filled polyester, PBT | Glass filled polyamid, PA 6.6 ²⁾ | Polyolifin cable with PE shrinkage tubing |
| <i>Electrical connection, 4-20 mA output (2 wire)</i> | | | | | |
| Pin 1: +supply Pin 2: ÷supply Pin 3: Not used Earth: Connected to MBS housing | Pin 1: +supply Pin 2: ÷supply Pin 3: Not used | Pin 1: +supply Pin 2: Not used Pin 3: Not used Pin 4: ÷supply | Pin 1: +supply Pin 2: ÷supply Pin 3: Ventilation Pin 4: Not used | Pin 1: +supply Pin 2: ÷supply Pin 3: Not used | Brown wire: +supply Black wire: ÷supply Red wire: Not used Orange: Not used Screen: Not connected to MBS housing |
| <i>Electrical connection, 0-5V, 1-5V, 1-6V, 0-10V output</i> | | | | | |
| Pin 1: +supply Pin 2: ÷supply Pin 3: Output Earth: Connected to MBS housing | Pin 1: +supply Pin 2: ÷supply Pin 3: Output | Pin 1: +supply Pin 2: not used Pin 3: Output Pin 4: ÷supply | Pin 1: +supply Pin 2: Output Pin 3: Ventilation Pin 4: ÷supply | Pin 1: +supply Pin 2: ÷supply Pin 3: Output | Brown wire: Output Black wire: ÷supply Red wire: + supply Orange: Not used Screen: Not connected to MBS housing |

1) Female plug: Glass filled polyester, PBT
 2) Wire: PETFE (teflon)
 Protection sleeve: PBT mesh (polyester)

Ordering of standard MBS 3000 with DIN 43650 plug Pg 9

| Pressure connection | Pressure range Pe | Type | Code no. |
|---------------------|----------------------|----------------------|----------|
| G 1/4 A (EN 837) | 0 - 1 bar | MBS 3000 1011-1 AB04 | 060G1113 |
| | 0 - 1.6 bar | MBS 3000 1211-1 AB04 | 060G1429 |
| | 0 - 2.5 bar | MBS 3000 1411-1 AB04 | 060G1122 |
| | 0 - 4 bar | MBS 3000 1611-1 AB04 | 060G1123 |
| | 0 - 6 bar | MBS 3000 1811-1 AB04 | 060G1124 |
| | 0 - 10 bar | MBS 3000 2011-1 AB04 | 060G1125 |
| | 0 - 16 bar | MBS 3000 2211-1 AB04 | 060G1133 |
| | 0 - 25 bar | MBS 3000 2411-1 AB04 | 060G1430 |
| | 0 - 40 bar | MBS 3000 2611-1 AB04 | 060G1105 |
| | 0 - 60 bar | MBS 3000 2811-1 AB04 | 060G1106 |
| | 0 - 100 bar | MBS 3000 3011-1 AB04 | 060G1107 |
| | 0 - 160 bar | MBS 3000 3211-1 AB04 | 060G1112 |
| | 0 - 250 bar | MBS 3000 3411-1 AB04 | 060G1111 |
| | 0 - 400 bar | MBS 3000 3611-1 AB04 | 060G1109 |
| 0 - 600 bar | MBS 3000 3811-1 AB04 | 060G1110 | |

Ordering of special versions

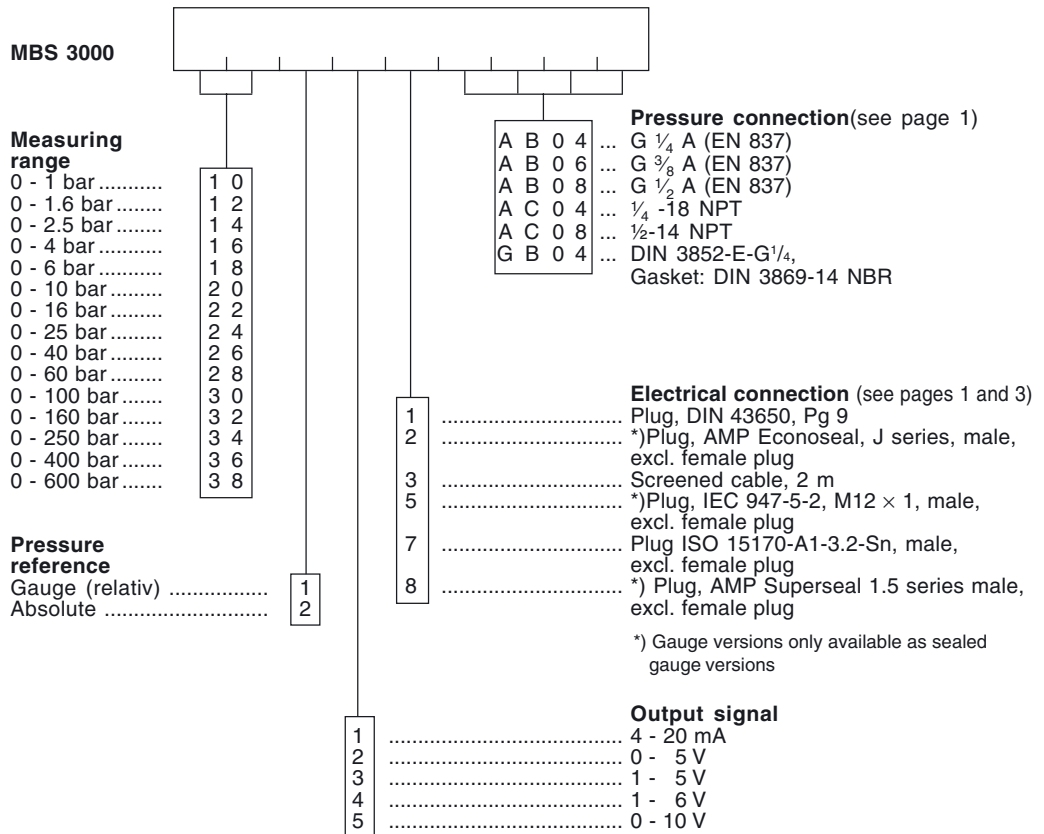

Danfoss can accept no responsibility for possible errors in catalogues, brochures and other printed material. Danfoss reserves the right to alter its products without notice. This also applies to products already on order provided that such alterations can be made without subsequential changes being necessary in specifications already agreed. All trademarks in this material are property of the respective companies. Danfoss and the Danfoss logotype are trademarks of Danfoss A/S. All rights reserved.



Panel Part Number:
99651229

Description
Control MPC E
3 X 3HP
3 X 480V

Selected Options: System Fault Light, Audible Alarm, Surge Protection, Pump Run Light, Normal/Emergency Switch

| | | | | | | | |
|---------|-----------|--------------------------------------|---|-------------------|--|-----------------------------|-------------|
| 0 | 6/18/2019 | Control MPC E 3 X 3HP 3 X 480V | This drawing and its content is the property of GRUNDFOS. It may not be copied for third parties or competitors. Changes are only to be made by GRUNDFOS. | PROJECT: 99651229 | | Panel Part Number: 99651229 | SHEET: 1/11 |
| 1 | 8/7/2019 | | | | | | |
| 2 | 8/16/2019 | | | | | | |
| | | | | EDW-WD-GPC-1310 | | | |
| ECM/Rev | Date | | | | | | |

Feeder Circuit Protection:

Feeder circuit protection to be provided by others.
Type and size to be based on local, state and national electrical codes

SCCR Rating: 100 kA RMS Symmetric,
480V

UL Type Rating: 3R

Largest Motor FLA and Panel Maximum FLA:

| | |
|------------------|---------|
| Motor Horsepower | 3HP |
| Motor FLA | 3.8FLA |
| Panel Max. FLA | 12.4FLA |

| Wire Type | Color | Abbr. |
|---|-----------------------|-------|
| +12/24VDC Power/PLC Input(s) | Blue | BU |
| -12/24VDC Power/PLC Input(s) | Blue w/White Stripe | BUWH |
| 115VAC Primary Line Power | Black | BK |
| 115VAC Neutral | White | WH |
| Ground/PE | Green/Yellow Stripe | GNYE |
| Analog Inputs | Orange | OG |
| Analog Outputs | Orange | OG |
| Digital Inputs (CU Components) | Violet | VT |
| Ground for Digital Inputs (CU Components) | Violet w/White Stripe | VTWH |
| Digital Outputs | Yellow | YE |
| Power L1 | Black | BK |
| Power L2 | Orange | OG |
| Power L3 | Red | RD |
| Power Neutral | White | WH |
| All Other Wiring | Brown | BN |

Safety / Application Notes:

**** Please Reference the "BOOSTERPAQ - HYDRO MPC"**

Installation and Operation Instructions "BEFORE" Applying power to Panel.

** Power supply wires in front of main disconnect switch have dangerous voltage even though the main disconnect switch is off.



** Control panel must be connected professionally to the earth / ground.

** GRUNDFOS MLE motors have an integrated variable frequency drive (VFD) which provides motor overload protection. If a system utilizes MLE motors, the motor overload protection is provided by the VFD and does not require any additional motor overload protection.

Cross Reference Definition

(##-##)
Sheet-Row

Wire Types

Internal Panel Wire 
External Wire 

| | |
|---------|-----------|
| 0 | 6/18/2019 |
| 1 | 8/7/2019 |
| 2 | 8/16/2019 |
| ECM/Rev | Date |

Control MPC E
3 X 3HP
3 X 480V

This drawing and its content is the property of GRUNDFOS. It may not be copied for third parties or competitors. Changes are only to be made by GRUNDFOS.

PROJECT: 99651229

EDW-WD-GPC-1310

GRUNDFOS 

Panel Part Number: 99651229

SHEET: 2/11

1 1-Table of Contents

| 2 | Drawing | Revision | Date | Created by | Description |
|----|-----------|----------|-----------|------------|---|
| 3 | <u>01</u> | 0 | 6/18/2019 | mfischer | Cover Page 01 |
| 4 | <u>02</u> | 0 | 6/18/2019 | mfischer | Cover Page 02 |
| 5 | <u>03</u> | 0 | 6/18/2019 | mfischer | Drawings list |
| 6 | <u>04</u> | 0 | 6/18/2019 | mfischer | Power 01 |
| 7 | <u>05</u> | 0 | 6/18/2019 | mfischer | Power 02 |
| 8 | <u>06</u> | 0 | 6/18/2019 | mfischer | Control 01 |
| 9 | <u>07</u> | 0 | 6/18/2019 | mfischer | Control 02 |
| 10 | <u>08</u> | 0 | 6/18/2019 | mfischer | Panel Layout |
| 11 | <u>09</u> | 0 | 6/18/2019 | mfischer | Panel Views |
| 12 | <u>10</u> | 0 | 6/18/2019 | mfischer | Bill Of Materials grouped by manufacturer Rev1.0 (Components) |
| 13 | <u>11</u> | 0 | 6/18/2019 | mfischer | Bill Of Materials grouped by manufacturer Rev1.0 (Components) |
| 14 | <u>12</u> | 0 | 6/18/2019 | mfischer | MPC Multi B Hybrid 3pumps |

20
21
22
23
24
25
26
27
28
29
30
31
32
33
34
35

| | | | | |
|---------|-----------|--------------------------------------|---|-------------------|
| 0 | 6/18/2019 | Control MPC E 3 X 3HP 3 X 480V | This drawing and its content is the property of GRUNDFOS. It may not be copied for third third parties or competitors. Changes are only to be made by GRUNDFOS. | PROJECT: 99651229 |
| 1 | 8/7/2019 | | | |
| 2 | 8/16/2019 | | | |
| ECM/Rev | Date | | | EDW-WD-GPC-1310 |

| | |
|---|-------------|
| GRUNDFOS  | |
| Panel Part Number: 99651229 | SHEET: 3/11 |

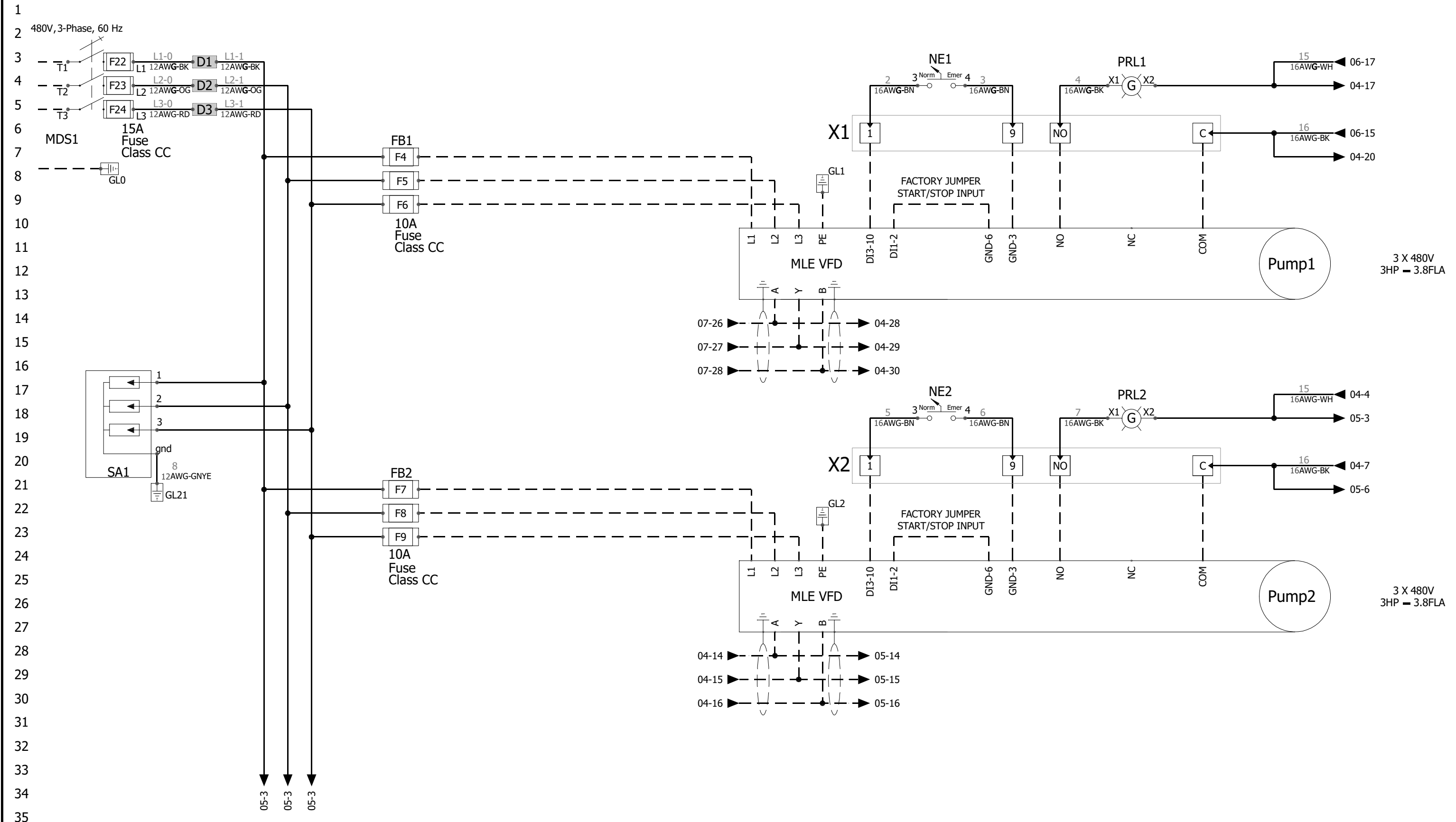

| | |
|---------|-----------|
| 0 | 6/18/2019 |
| 1 | 8/7/2019 |
| 2 | 8/16/2019 |
| ECM/Rev | Date |

Control MPC E
3 X 3HP
3 X 480V

This drawing and its content is the property of GRUNDFOS. It may not be copied for third parties or competitors. Changes are only to be made by GRUNDFOS.

PROJECT: 99651229

EDW-WD-GPC-1310



Panel Part Number: 99651229

SHEET: 4/11

1
2
3
4
5
6
7
8
9
10
11
12
13
14
15
16
17
18
19
20
21
22
23
24
25
26
27
28
29
30
31
32
33
34
35

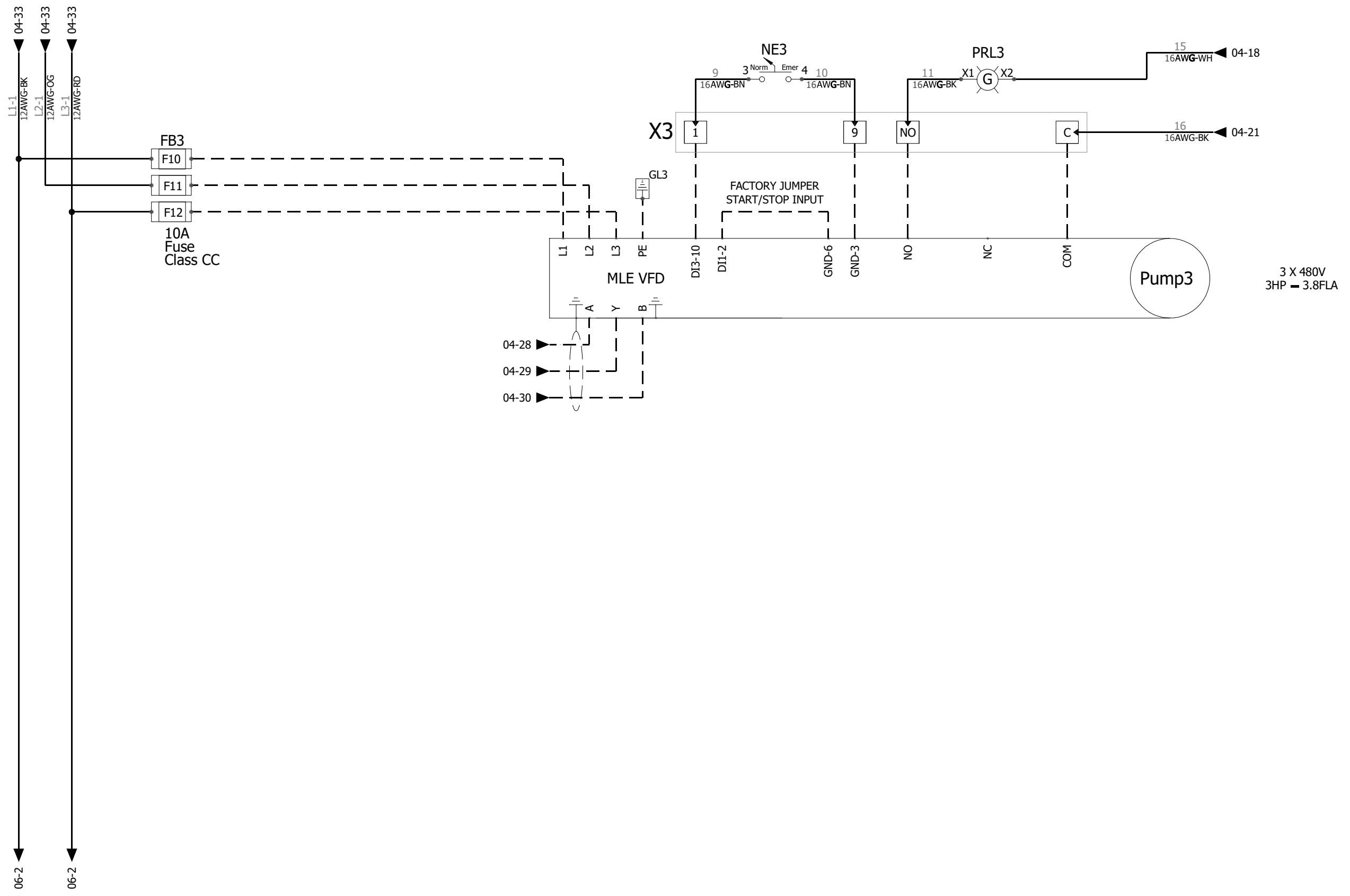

| | | | | | | |
|-----------------|-----------|--------------------------------------|---|----------|----------|---|
| 0 | 6/18/2019 | Control MPC E 3 X 3HP 3 X 480V | This drawing and its content is the property of GRUNDFOS. It may not be copied for third parties or competitors. Changes are only to be made by GRUNDFOS. | PROJECT: | 99651229 |  |
| 1 | 8/7/2019 | | | | | |
| 2 | 8/16/2019 | | | | | |
| EDW-WD-GPC-1310 | | | | | | Panel Part Number: 99651229 |
| ECM/Rev | Date | | | | | SHEET: 5/11 |

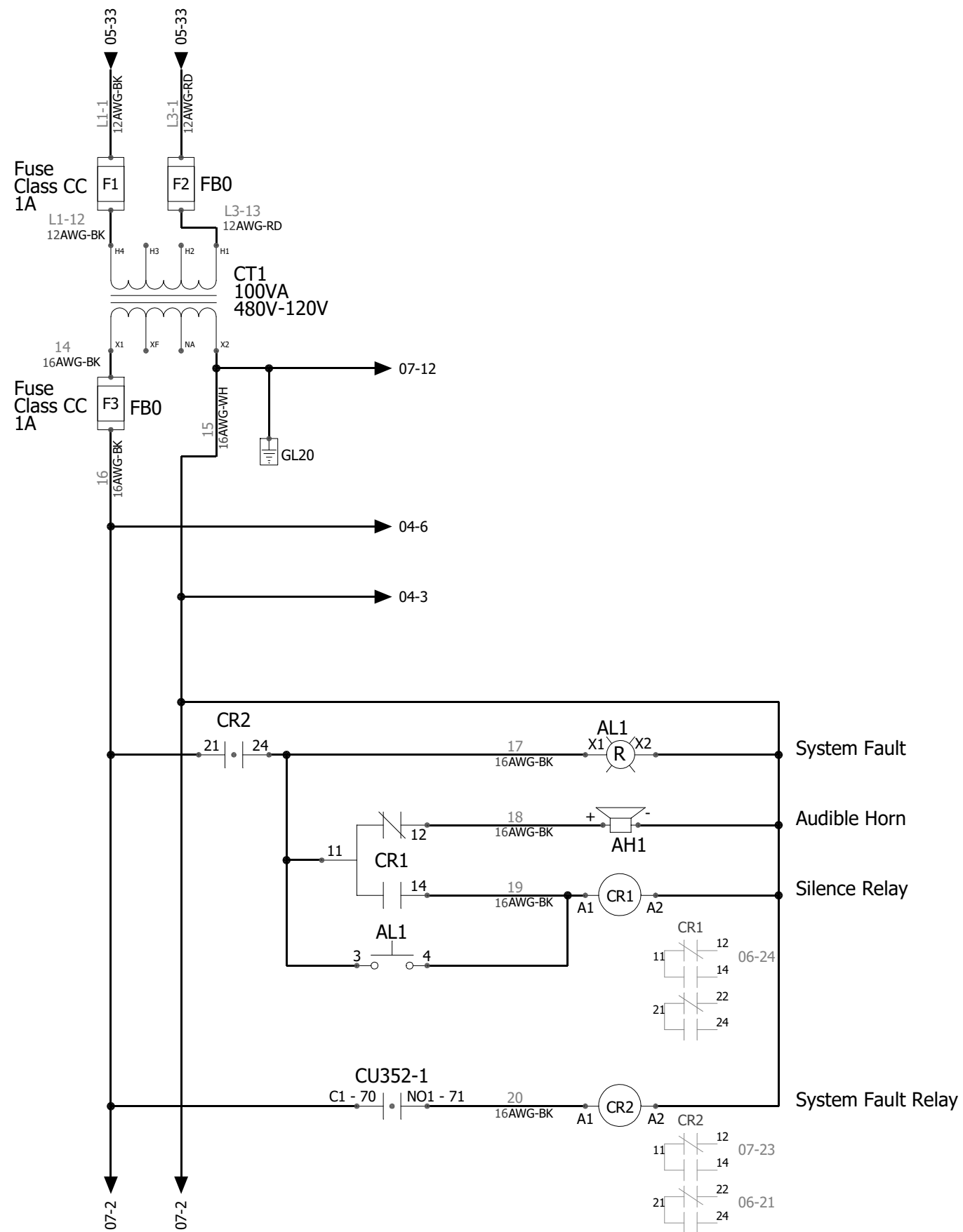

1
2
3
4
5
6
7
8
9
10
11
12
13
14
15
16
17
18
19
20
21
22
23
24
25
26
27
28
29
30
31
32
33
34
35

| | |
|---------|-----------|
| 0 | 6/18/2019 |
| 1 | 8/7/2019 |
| 2 | 8/16/2019 |
| ECM/Rev | Date |

Control MPC E
3 X 3HP
3 X 480V

This drawing and its content is the property of GRUNDFOS. It may not be copied for third parties or competitors. Changes are only to be made by GRUNDFOS.

PROJECT: 99651229

EDW-WD-GPC-1310

GRUNDFOS 

Panel Part Number: 99651229 SHEET: 6/11

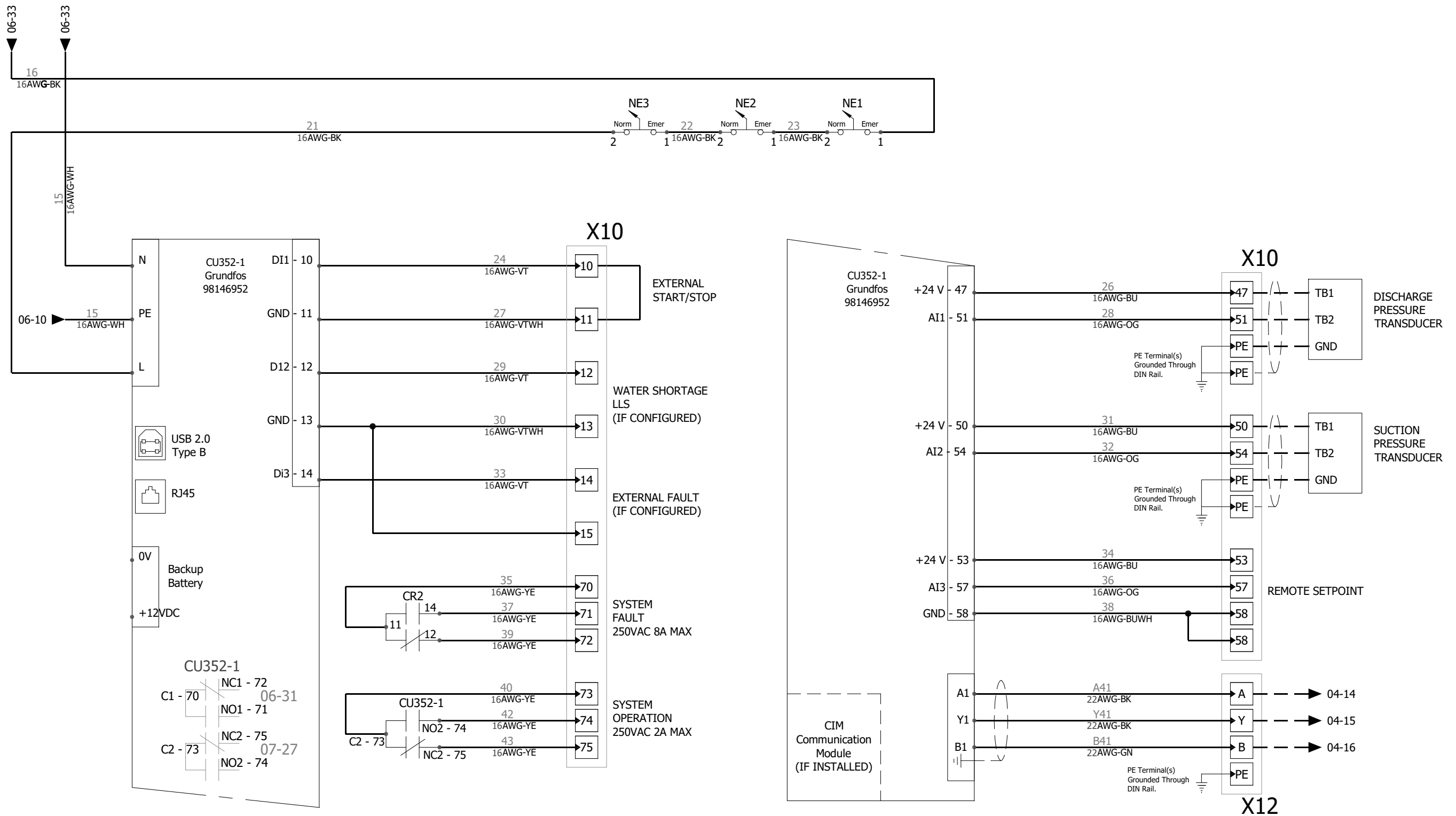

CIM COMMUNICATION MODULE TERMINATIONS

| CIM | Terminal 1 | Terminal 2 | Terminal 3 | Terminal 4 |
|---------|------------------------------------|----------------------|-----------------------|-------------------------------|
| CIM 110 | LON | LON terminal A | LON terminal B | LON terminal for cable screen |
| CIM 150 | PROFIBUS DP | PROFIBUS terminal B | PROFIBUS terminal A | PROFIBUS terminal DGND |
| CIM 200 | Modbus RTU | Modbus terminal D1 | Modbus terminal D0 | Modbus terminal common/GND |
| CIM 300 | BACnet MS/TP | BACnet Plus terminal | BACnet Minus terminal | BACnet Ground terminal |
| CIM 500 | BACnet IP, Modbus TCP, PROFINET IO | RJ45 | RJ45 | |

1
2
3
4
5
6
7
8
9
10
11
12
13
14
15
16
17
18
19
20
21
22
23
24
25
26
27
28
29
30
31
32
33
34
35

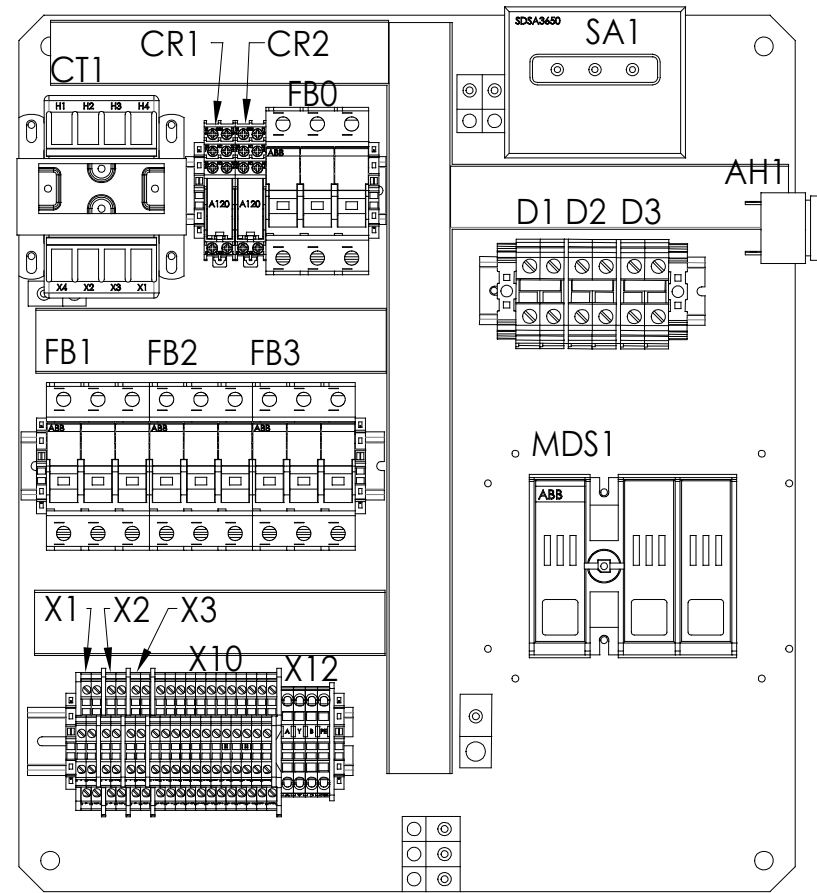

| | |
|---------|-----------|
| 0 | 6/18/2019 |
| 1 | 8/7/2019 |
| 2 | 8/16/2019 |
| ECM/Rev | Date |

Control MPC E
3 X 3HP
3 X 480V

This drawing and its content is the property of GRUNDFOS. It may not be copied for third parties or competitors. Changes are only to be made by GRUNDFOS.

PROJECT: 99651229

EDW-WD-GPC-1310



Panel Part Number: 99651229

SHEET: 8/11

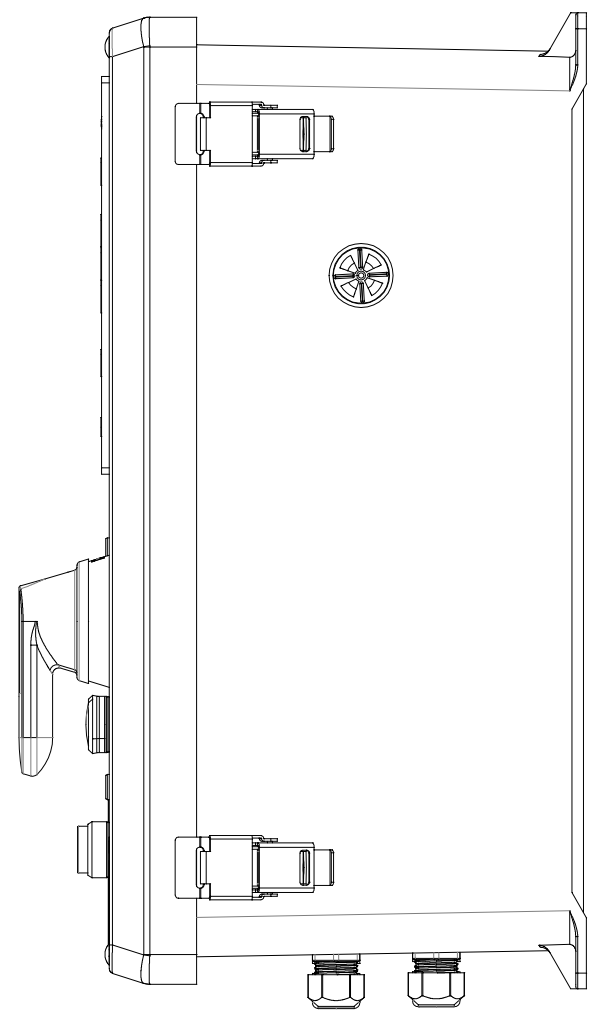
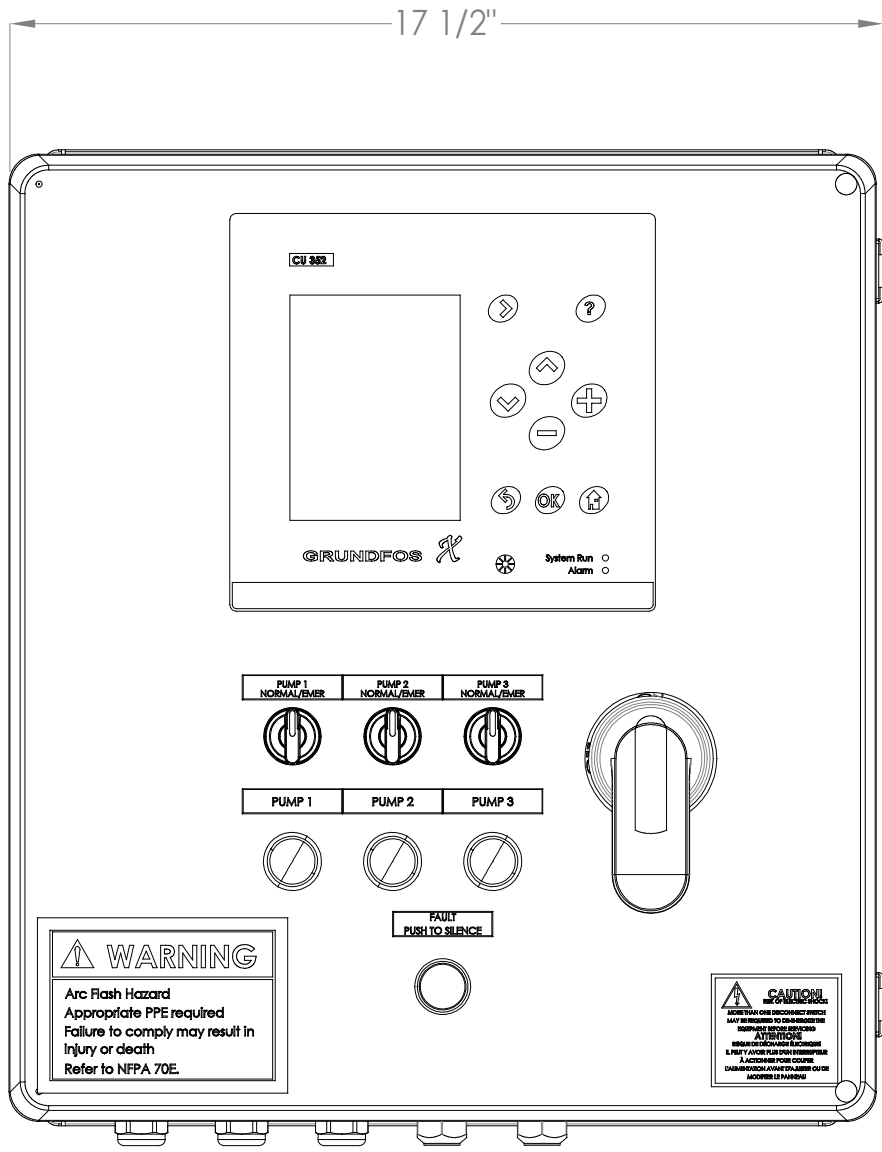
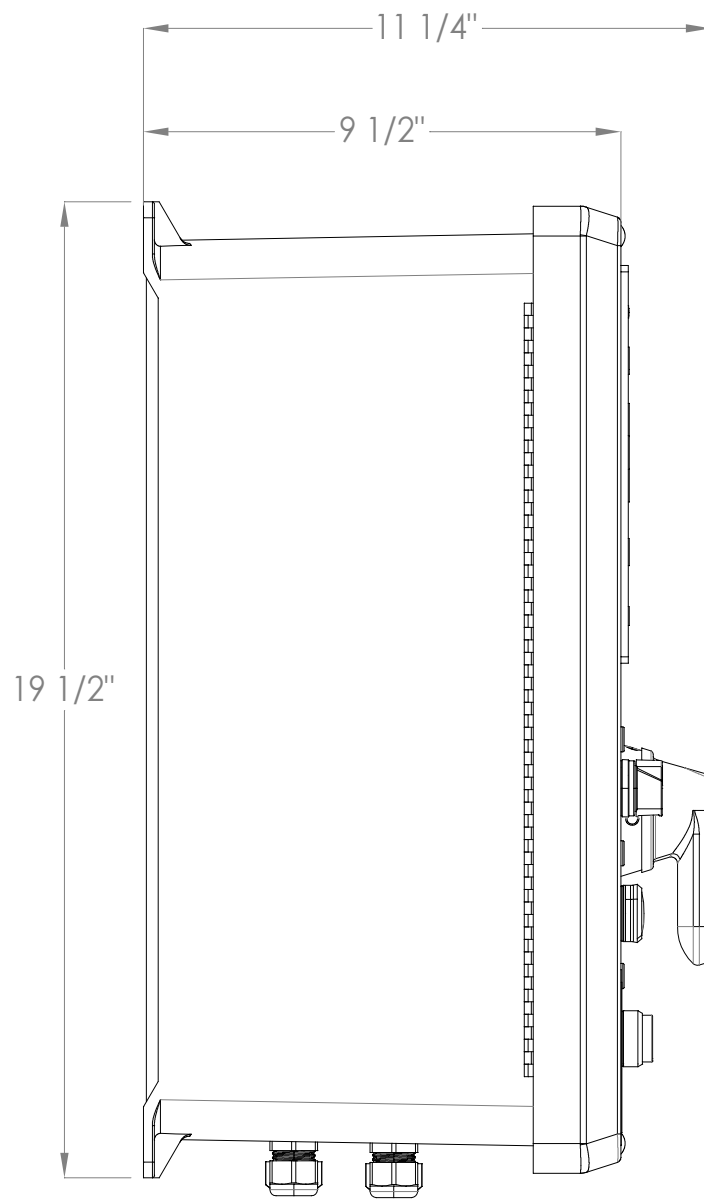

CLEARANCE FROM FRONT OF ENCLOSURE MUST BE 36"

1
2
3
4
5
6
7
8
9
10
11
12
13
14
15
16
17
18
19
20
21
22
23
24
25
26
27
28
29
30
31
32
33
34
35

| | | | | | | |
|---------|-----------|--------------------------------------|---|----------|-----------------|-----------------------------|
| 0 | 6/18/2019 | Control MPC E 3 X 3HP 3 X 480V | This drawing and its content is the property of GRUNDFOS. It may not be copied for third parties or competitors. Changes are only to be made by GRUNDFOS. | PROJECT: | 99651229 | |
| 1 | 8/7/2019 | | | | | |
| 2 | 8/16/2019 | | | | | |
| ECM/Rev | Date | | | | EDW-WD-GPC-1310 | Panel Part Number: 99651229 |
| | | | | | | SHEET: 9/11 |

1
2
3
4
5
6
7
8
9
10
11
12
13
14
15
16
17
18
19
20
21
22
23
24
25
26
27
28
29
30
31
32
33
34
35

| Article Number | Mark | Manufacturer | Reference | Description | Quantity | Component Type |
|-------------------------|---|--------------|-------------------------|--|----------|------------------------------------|
| 13-16-26-1241 | FB0 , FB1 , FB2 , FB3 | ABB | E9330CCS | Fuse Block; 3P, 30 A, Class CC, Indicator, Padlockable | 4 | Fuse Block 3-pole |
| 13-16-66-1615 | <u>MDS1</u> | ABB | OHY80L6 | Disconnect Handle; Red/Yellow, 30/60/100/250A, Type 4, 4X, 3R, 12 | 1 | Main Disconnect |
| 13-16-66-1506 | <u>MDS1</u> | ABB | OHZX10 | Alignment Ring; Use on all Pistol Grip Handles | 1 | Main Disconnect |
| 13-16-66-1431 | <u>MDS1</u> | ABB | OS30FACC12 | Disconnect Switch; 30A, Fuseable, 600V, 3-Pole, UL98, Class CC, Center Shaft | 1 | Main Disconnect |
| 13-16-66-1610 | <u>MDS1</u> | ABB | OXp6X500 | Disconnect Shaft; 19.7", 6x500 | 1 | Main Disconnect |
| 13-16-81-1463 | <u>CT1</u> | Acme | TB100A005C | Transformer; 100VA, P/208/230/460V, S/115V | 1 | Controls Transformer |
| 13-16-26-1060 | F1 , F2 , F3 | F.Shaw | ATQR1 | Fuse; 1A, 600V, 13/32" x 1 1/2", Class CC | 3 | Fuse |
| 13-16-26-1066 | F4 , F5 , F6 , F7 , F8 , F9 , F10 , F11 , F12 | F.Shaw | ATQR10 | Fuse; 10A, 600V, 13/32" x 1 1/2", Class CC | 9 | Fuse |
| 13-16-26-1068 | F22 , F23 , F24 | F.Shaw | ATQR15 | Fuse; 15A, 600V, 13/32" x 1 1/2", Class CC | 3 | Fuse |
| 13-16-56-1029 | <u>AH1</u> | Floyd Bell | SP-1081 | Alarm; 120V, 95db, Reduced Sensitivity, Extra Fast Warble, Panel Mount | 1 | Audible Horn |
| 13-16-39-1093 | <u>CU352-1</u> | Grundfos | 98146952 | (CM) Logic Module; Grundfos MPC Controller (CU352) | 1 | CU352 |
| 13-16-86-1034 | L1 | Heyco | Hey-M3231 UL Listed | Cord Grip, 1/2" NPT Black Liquid tight Nema 6x Rated | 3 | Main electrical closet |
| 13-16-86-1035 | L1 | Heyco | Hey-M4518 | Cord Grip, 1/2 NPT Black-No Nut | 6 | Main electrical closet |
| 13-16-46-1073 | CR1 , CR2 | Idec | RJ2S-CL-A120 | Relay; 120V, DPDT, 8A, Indicator | 2 | Silence Relay , System Fault Relay |
| 13-16-46-1283 | CR1 , CR2 | Idec | SJ2S-07LW | Socket; 8 Pin, DIN/Pnl Mt, for RJ Relays | 2 | Silence Relay , System Fault Relay |
| 13-66-11-1130 | SAB1 | OSI | 13-66-11-1130 | Bracket; Surge Arrestor | 1 | SA Bracket |
| 65-BP-1816-MPC-CME | L1 | OSI | 65-BP-1816-MPC-CME | Backplate; MPC-CME-Hybrid-1816 | 1 | Main electrical closet |
| 65-ENCL-1816-3P-MPC-CME | L1 | OSI | 65-ENCL-1816-3P-MPC-CME | Enclosure; 18X16 MPC-CME 3pump | 1 | Main electrical closet |
| 65-LIGHT-1R-032 | <u>AL1</u> | OSI | 65-light-1R-032 | Push Button Light; Fault, Push to Silence | 1 | System Fault |
| 65-SWITCH-2-12 | NE1 , NE2 , NE3 | OSI | 65-SWITCH-2-12 | Switch; Two Position, 1-NO, 1-NC | 3 | Normal/Emergency Switch |
| 65-TB-CU352-DB | <u>X10 1</u> | OSI | 65-TB-CU352-DB | Terminal Blocks; Double Stack, X10 CU352 Terminals | 1 | CU352 Terminal Blocks |

| | |
|---------|-----------|
| 0 | 6/18/2019 |
| 1 | 8/7/2019 |
| 2 | 8/16/2019 |
| ECM/Rev | Date |

Control MPC E
3 X 3HP
3 X 480V

This drawing and its content is the property of GRUNDFOS. It may not be copied for third parties or competitors. Changes are only to be made by GRUNDFOS.

PROJECT: 99651229
 EDW-WD-GPC-1310

GRUNDFOS 

Panel Part Number: **99651229** SHEET: 10/11

1
2
3
4
5
6
7
8
9
10
11
12
13
14
15
16
17
18
19
20
21
22
23
24
25
26
27
28
29
30
31
32
33
34
35

| Article Number | Mark | Manufacturer | Reference | Description | Quantity | Component Type |
|----------------------|--|--------------|----------------------|--|----------|-------------------------------------|
| 65-TB-GENI | X12 1 | OSI | 65-TB-GENI | Terminal Blocks; X12 Geni Bus Terminals | 1 | Geni Bus Terminal Blocks |
| 65-TB-SINGLE-PUMP-DB | X1 1 , X2 1 , X3 1 | OSI | 65-TB-SINGLE-PUMP-DB | Terminal Blocks; MLE Pump Control | 3 | Pump Control Terminal Blocks |
| 13-16-71-1516 | D1 , D2 , D3 | Phoenix | 3005950 (FBS 2-12) | Terminal Link; for UT 16 terminal blocks, 2 pole, red, 85 Amp, 600 V, 16-4 AWG | 3 | Distribution Terminals |
| 13-16-71-1455 | D1 , D2 , D3 | Phoenix | 3044199 (UT-16) | Terminal Block; 16/4AWG, 85A, 1P, 600V, 12mm | 6 | Distribution Terminals |
| 13-16-86-1680 | GL0 , GL1 , GL2 , GL3 , GL20 , GL21 | Raco | TA2-Bulk | Ground Lug; 2AWG, Burndy | 6 | Ground Lug |
| 13-16-61-1010 | SA1 | Schneider | SDSA 3650 | Surge Arrestor; 3 Phase, 600V, WYE | 1 | Surge Arrestor |
| 13-16-36-1421 | PRL1 , PRL2 , PRL3 | Siemens | 3SU11036AA401AA0 | Pilot Light; Green, 110 VAC Complete | 3 | Pump 1 Run Light , Pump 2 Run Light |

| | |
|---------|-----------|
| 0 | 6/18/2019 |
| 1 | 8/7/2019 |
| 2 | 8/16/2019 |
| ECM/Rev | Date |

Control MPC E
3 X 3HP
3 X 480V

This drawing and its content is the property of GRUNDFOS. It may not be copied for third parties or competitors. Changes are only to be made by GRUNDFOS.

PROJECT: 99651229

EDW-WD-GPC-1310



GRUNDFOS

| | |
|-----------------------------|--------------|
| Panel Part Number: 99651229 | SHEET: 11/11 |
|-----------------------------|--------------|