

PROJECT: _____	UNIT TAG: _____	QUANTITY: _____
REPRESENTATIVE: _____	TYPE OF SERVICE: _____	DATE: _____
ENGINEER: _____	SUBMITTED BY: _____	DATE: _____
CONTRACTOR: _____	APPROVED BY: _____	DATE: _____
	ORDER NO.: _____	DATE: _____



CRNE 3-2 N-FGJ-A-E-HQQE

Vertical, multistage centrifugal pump with integrated frequency converter. Pump materials in contact with the liquid are in high-grade stainless steel (EN 1.4401)

Note! Product picture may differ from actual product

Conditions of Service		Pump Data		Motor Data	
Liquid:	Water	Max pressure at stated temp:	363 psi / 250 °F	Rated power - P2:	0.5 HP
Temperature:	68 °F	Liquid temperature range:	-4 .. 248 °F	Rated voltage:	200-240 V
Specific Gravity:	1.000	Maximum ambient temperature:	122 °F	Mains frequency:	60 Hz
		Shaft seal:	HQQE	Enclosure class:	IP55
		Product number:	99340808	Insulation class:	F
				Motor protection:	ELEC
				Motor type:	71A
				Eta 1/1:	84.0 %

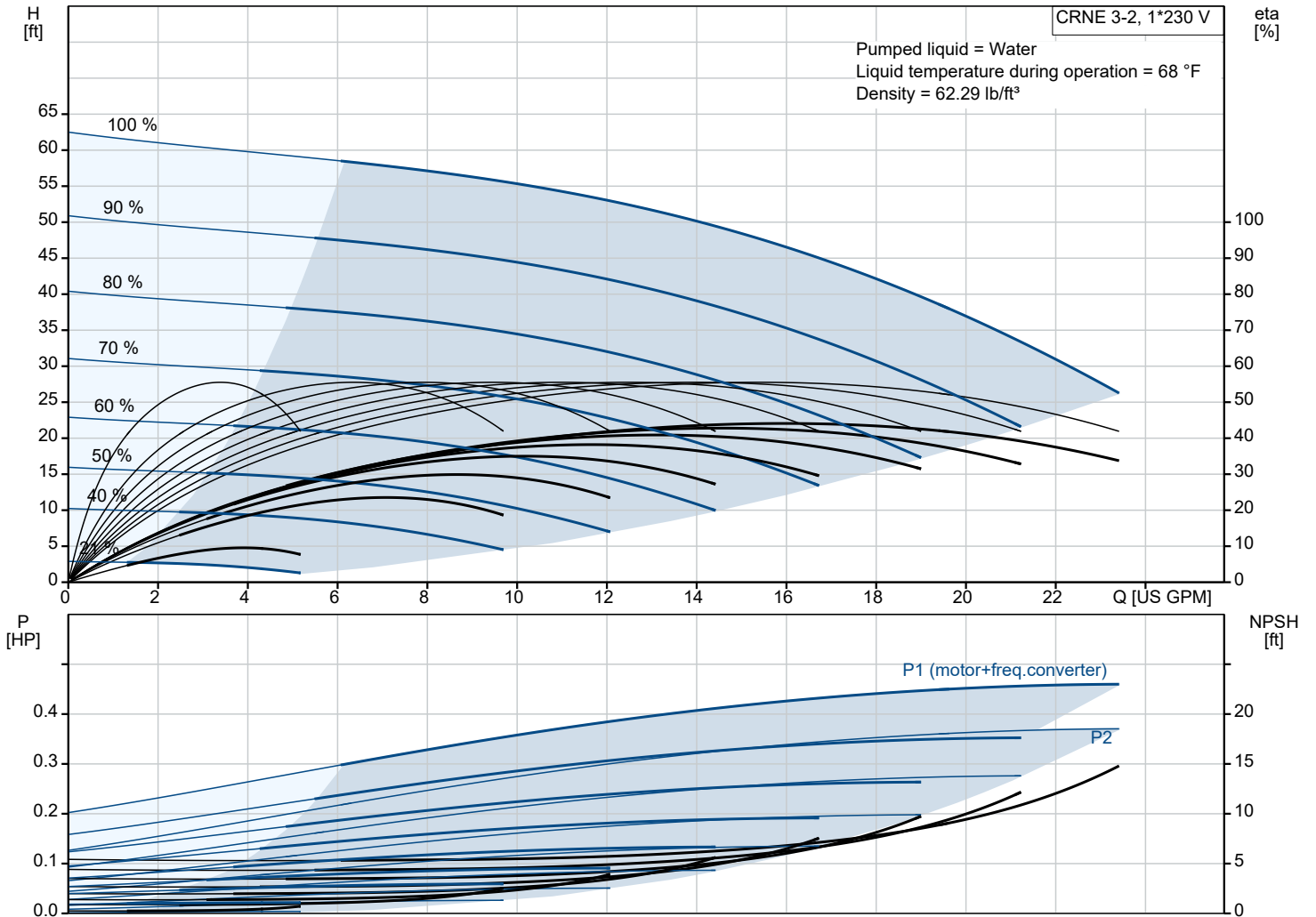

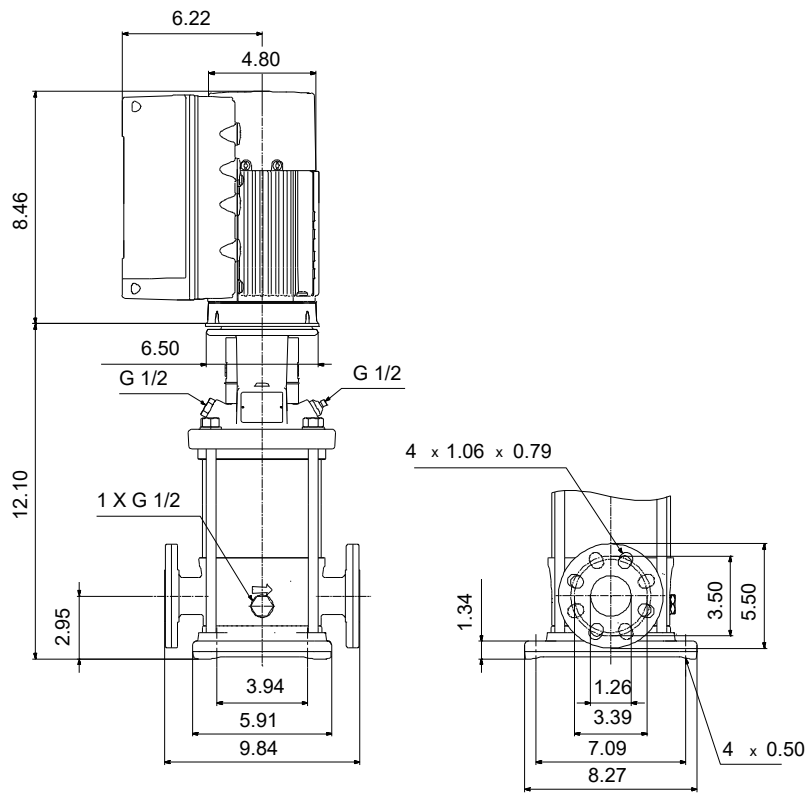

Materials:

Base: Stainless steel
 Base: EN 1.4408
 Base: AISI 316
 Impeller: Stainless steel
 Impeller: AISI 316
 Impeller: EN 1.4401
 Material code: A
 Code for rubber: E

Qty.	Description
------	-------------

1 **CRNE 3-2 N-FGJ-A-E-HQQE**



Note! Product picture may differ from actual product

Product No.: [99340808](#)

Vertical, multistage centrifugal pump with inlet and outlet ports on same the level (inline). Pump materials in contact with the liquid are in high-grade stainless steel. A cartridge shaft seal ensures high reliability, safe handling, and easy access and service. Power transmission is via a rigid split coupling. Pipe connection is via combined DIN-ANSI-JIS flanges.

The pump is fitted with a 1-phase, fan-cooled, permanent-magnet, synchronous motor.

The motor efficiency is classified as IE5 in accordance with IEC 60034-30-2.

The motor includes a frequency converter and PI controller in the motor terminal box. This enables continuously variable control of the motor speed, which again enables adaptation of the performance to a given requirement.

The operating panel on the motor terminal box features a four-inch TFT display, push-buttons and the Grundfos Eye indicator.

The display gives an intuitive and user-friendly interface to all functions.

The push-buttons are used to navigate through the menu structure to access pump and performance data on site and enable setting of required setpoint as well as setting of pump to "Min." or "Max." operation or to "Stop".

Communication with the pump is also possible by means of Grundfos GO Remote (accessory). The remote control enables further settings as well as reading out of a number of parameters such as "Actual value", "Speed", "Power input" and total "Power consumption".

The Grundfos Eye indicator on the operating panel provides visual indication of pump status:

- "Power on": Motor is running (rotating green indicator lights) or not running (permanently green indicator lights)
- "Warning": Motor is still running (rotating yellow indicator lights) or has stopped (permanently yellow indicator lights)
- "Alarm": Motor has stopped (flashing red indicator lights).

The terminal box has a number of inputs and outputs enabling the motor to be used in advanced applications where many inputs and outputs are required:

- two dedicated digital inputs
- three analog inputs, 0(4)-20 mA, 0-5 V, 0-10 V, 0.5 - 3.5 V; the factory-fitted pressure sensor is connected to one of these inputs
- 5 V voltage supply to potentiometer and sensor
- one analog output, 0-10 V, 0(4)-20 mA
- two configurable digital inputs or open-collector outputs
- two Pt100/Pt1000 inputs
- LiqTec, dry-running protection sensor input
- Grundfos Digital Sensor input and output
- 24 V voltage supply for sensors
- two signal-relay outputs (potential-free contacts)
- GENIbus connection
- interface for Grundfos CIM fieldbus module.

Liquid:

Pumped liquid: Water
 Liquid temperature range: -4 .. 248 °F
 Selected liquid temperature: 68 °F
 Density: 62.29 lb/ft³

Technical:

Pump speed on which pump data are based: 3436 rpm
 Rated flow: 15.4 US GPM
 Rated head: 44.95 ft
 Pump orientation: Vertical
 Shaft seal arrangement: Single
 Code for shaft seal: HQQE
 Approvals: CURUS
 Approvals for drinking water: NSF/ANSI 61
 Curve tolerance: ISO9906:2012 3B

Materials:

Qty.	Description	
	Base:	Stainless steel EN 1.4408 AISI 316
	Impeller:	Stainless steel EN 1.4401 AISI 316
	Bearing:	SIC
	Installation:	
	t max amb:	122 °F
	Maximum operating pressure:	362.59 psi
	Max pressure at stated temp:	363 psi / 250 °F 363 psi / -4 °F
	Type of connection:	DIN / ANSI / JIS
	Size of inlet connection:	DN 25/32
	Size of outlet connection:	DN 25/32
	Pressure rating for connection:	PN 25
	Flange rating inlet:	300 lb
	Flange size for motor:	56C
	Electrical data:	
	Motor standard:	NEMA
	Motor type:	71A
	IE Efficiency class:	IE5
	Rated power - P2:	0.5 HP
	Power (P2) required by pump:	0.5 HP
	Mains frequency:	60 Hz
	Rated voltage:	1 x 200-240 V
	Service factor:	1.0
	Rated current:	2.40-2.10 A
	Cos phi - power factor:	0.96
	Rated speed:	360-4000 rpm
	Efficiency:	84.0%
	Motor efficiency at full load:	84.0 %
	Enclosure class (IEC 34-5):	IP55
	Insulation class (IEC 85):	F
	Motor No:	98362269
	Controls:	
	Frequency converter:	Built-in
	Pressure sensor:	Y
	Others:	
	Net weight:	58.6 lb
	Gross weight:	69.6 lb
	Shipping volume:	4.94 ft³

99340808 CRNE 3-2 N-FGJ-A-E-HQQE 60 Hz



Note! All units are in [in] unless others are stated.