

PROJECT: _____	UNIT TAG: _____	QUANTITY: _____
REPRESENTATIVE: _____	TYPE OF SERVICE: _____	DATE: _____
ENGINEER: _____	SUBMITTED BY: _____	DATE: _____
CONTRACTOR: _____	APPROVED BY: _____	DATE: _____
	ORDER NO.: _____	DATE: _____



## CRNE 15-12 N-P-A-E-HQQE

Vertical, multistage centrifugal pump with integrated frequency converter. Pump materials in contact with the liquid are in high-grade stainless steel (EN 1.4401)

Note! Product picture may differ from actual product

Conditions of Service		Pump Data		Motor Data	
Liquid:	Water	Max pressure at stated temp:	363 psi / 250 °F	Rated power - P2:	25 HP
Temperature:	68 °F	Liquid temperature range:	-4 .. 248 °F	Rated voltage:	460 V
Specific Gravity:	1.000	Maximum ambient temperature:	104 °F	Mains frequency:	60 Hz
		Shaft seal:	HQQE	Enclosure class:	IP55
		Product number:	98181589	Insulation class:	F
				Motor protection:	YES
				Motor type:	160AC
				Eta 1/1:	91.7 %

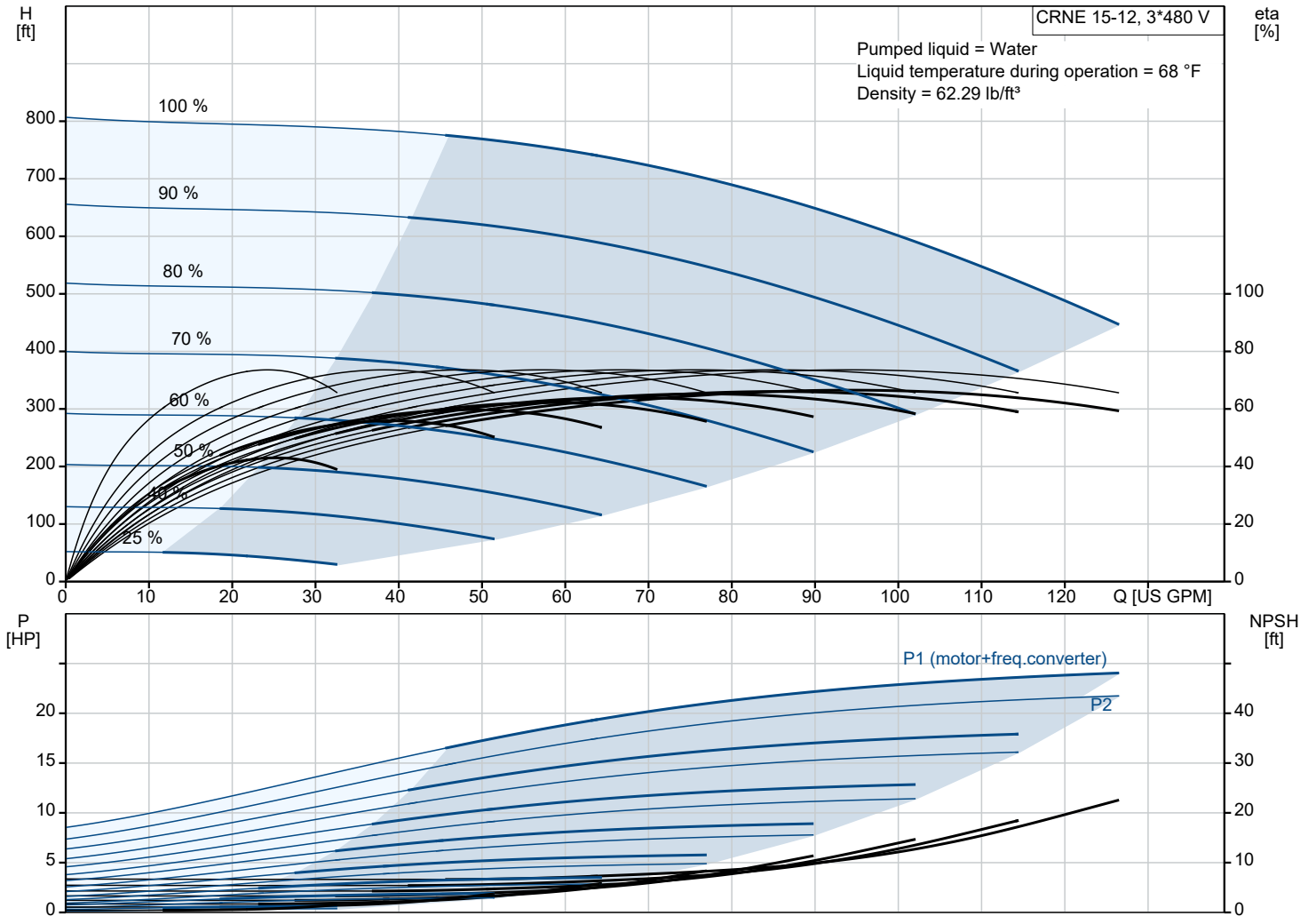

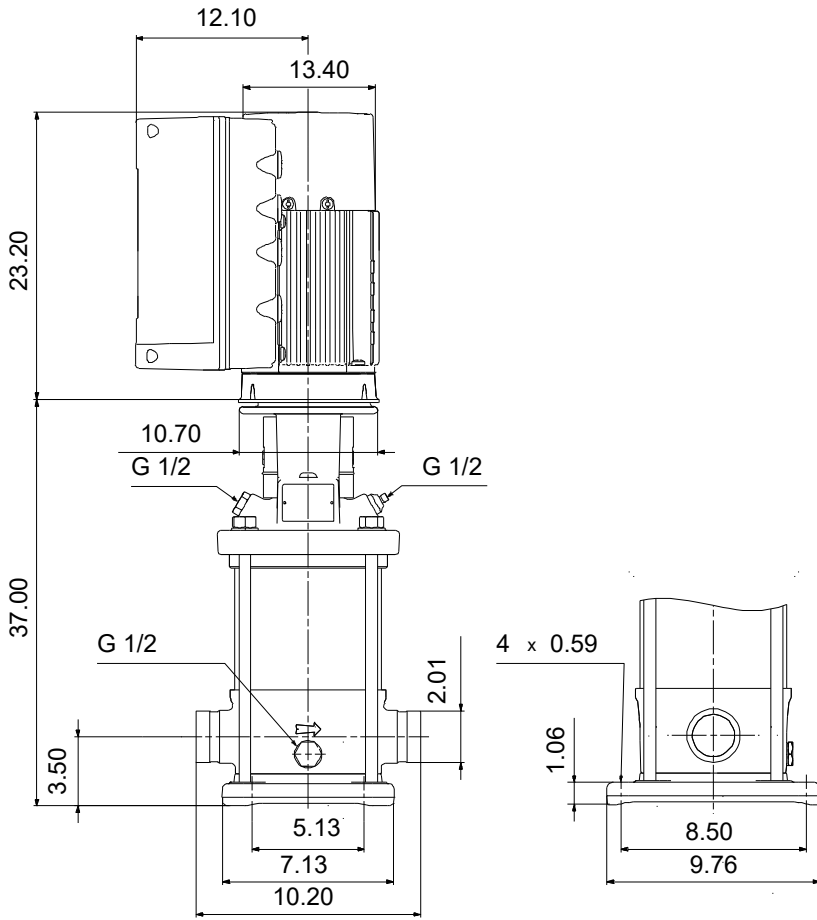

**Materials:**

- Base: Stainless steel
- Base: EN 1.4408
- Base: AISI 316
- Impeller: Stainless steel
- Impeller: AISI 316
- Impeller: EN 1.4401
- Material code: A
- Code for rubber: E

Qty.	Description
1	<p data-bbox="119 85 443 118"><b>CRNE 15-12 N-P-A-E-HQQE</b></p> <p data-bbox="119 118 391 141">Product No.: <a href="#">98181589</a></p> <p data-bbox="119 174 1520 253">Vertical, multistage centrifugal pump with inlet and outlet ports on same the level (inline). Pump materials in contact with the liquid are in high-grade stainless steel. A cartridge shaft seal ensures high reliability, safe handling, and easy access and service. Power transmission is via a rigid split coupling. Pipe connection is via PJE (Victaulic®) couplings.</p> <p data-bbox="119 264 842 286">The pump is fitted with a 3-phase, fan-cooled asynchronous motor.</p> <p data-bbox="119 297 1520 342">The motor includes a frequency converter and PI controller in the motor terminal box. This enables continuously variable control of the motor speed, which again enables adaptation of the performance to a given requirement.</p> <p data-bbox="119 353 1481 398">An operating panel on the motor terminal box enables setting of required setpoint as well as setting of pump to "Min." or "Max." operation or to "Stop". The operating panel has indicator lights for "Operation" and "Fault".</p> <p data-bbox="119 409 1473 477">Communication with the pump is possible by means of Grundfos GO Remote (accessory). The remote control enables further settings as well as reading out of a number of parameters such as "Actual value", "Speed", "Power input" and total "Power consumption".</p> <p data-bbox="119 488 722 510">The terminal box holds terminals for these connections:</p> <ul data-bbox="159 521 1457 846" style="list-style-type: none"> <li>• pump start/stop input (potential-free contact)</li> <li>• remote setpoint setting via analog signal, 0-10 V, 0(4)-20 mA</li> <li>• 10 V voltage supply for setpoint potentiometer, I<sub>max</sub> = 5 mA</li> <li>• three analog sensor inputs, 0-10 V, 0(4)-20 mA; the factory-fitted pressure sensor is connected to one of these inputs</li> <li>• 24 V voltage supply for sensor, I<sub>max</sub> = 40 mA</li> <li>• one analog output</li> <li>• three digital inputs</li> <li>• two Pt100 inputs</li> <li>• two potential-free fault signal relays with changeover contact, reporting "Fault", "Operation" or "Ready"</li> <li>• RS-485 GENibus connection</li> <li>• interface for Grundfos CIM fieldbus module.</li> </ul> <p data-bbox="119 880 204 902">Liquid:</p> <p data-bbox="119 913 563 936">Pumped liquid: Water</p> <p data-bbox="119 947 611 969">Liquid temperature range: -4 .. 248 °F</p> <p data-bbox="119 981 547 1003">Selected liquid temperature: 68 °F</p> <p data-bbox="119 1014 611 1037">Density: 62.29 lb/ft<sup>3</sup></p> <p data-bbox="119 1059 244 1081">Technical:</p> <p data-bbox="119 1093 746 1115">Pump speed on which pump data are based: 3521 rpm</p> <p data-bbox="119 1126 643 1149">Rated flow: 90.3 US GPM</p> <p data-bbox="119 1160 579 1182">Rated head: 644.4 ft</p> <p data-bbox="119 1193 563 1216">Actual impeller diameter: 4.13 in</p> <p data-bbox="119 1227 579 1249">Pump orientation: Vertical</p> <p data-bbox="119 1261 563 1283">Shaft seal arrangement: Single</p> <p data-bbox="119 1294 563 1317">Code for shaft seal: HQQE</p> <p data-bbox="119 1328 579 1350">Approvals: CURUS</p> <p data-bbox="119 1361 643 1384">Approvals for drinking water: NSF/ANSI 61</p> <p data-bbox="119 1395 691 1417">Curve tolerance: ISO9906:2012 3B</p> <p data-bbox="119 1440 236 1462">Materials:</p> <p data-bbox="119 1473 651 1529">Base: Stainless steel EN 1.4408 AISI 316</p> <p data-bbox="119 1541 651 1619">Impeller: Stainless steel EN 1.4401 AISI 316</p> <p data-bbox="119 1630 531 1653">Bearing: SIC</p> <p data-bbox="119 1686 252 1709">Installation:</p> <p data-bbox="119 1720 563 1742">t max amb: 104 °F</p> <p data-bbox="119 1753 611 1776">Maximum operating pressure: 362.59 psi</p> <p data-bbox="119 1787 667 1832">Max pressure at stated temp: 363 psi / 250 °F 363 psi / -4 °F</p> <p data-bbox="119 1843 531 1865">Type of connection: PJE</p> <p data-bbox="119 1877 563 1899">Size of inlet connection: DN 50</p> <p data-bbox="119 1910 563 1933">Size of outlet connection: DN 50</p> <p data-bbox="119 1944 563 1966">Pressure rating for connection: PN 50</p> <p data-bbox="119 1977 563 2000">Flange size for motor: 284TC</p> <p data-bbox="119 2022 292 2045">Electrical data:</p> <p data-bbox="119 2056 563 2078">Motor standard: NEMA</p> <p data-bbox="119 2089 563 2112">Motor type: 160AC</p> <p data-bbox="119 2123 786 2145">IE Efficiency class: NEMA Premium / IE3 60Hz</p> <p data-bbox="119 2157 563 2179">Rated power - P2: 25 HP</p>

Qty.	Description
	Power (P2) required by pump: 25 HP
	Mains frequency: 60 Hz
	Rated voltage: 3 x 460 V
	Service factor: 1.15
	Rated current: 30.5 A
	Cos phi - power factor: 0.88
	Rated speed: 480-3540 rpm
	Efficiency: IE3 91,7%
	Motor efficiency at full load: 91.7 %
	Number of poles: 2
	Enclosure class (IEC 34-5): IP55
	Insulation class (IEC 85): F
	Motor No: 85901138
	Controls:
	Frequency converter: Built-in
	Pressure sensor: Y
	Others:
	DOE Pump Energy Index VL: 0.47
	Net weight: 426 lb
	Gross weight: 553 lb
	Shipping volume: 21.9 ft <sup>3</sup>

# 98181589 CRNE 15-12 N-P-A-E-HQQE 60 Hz

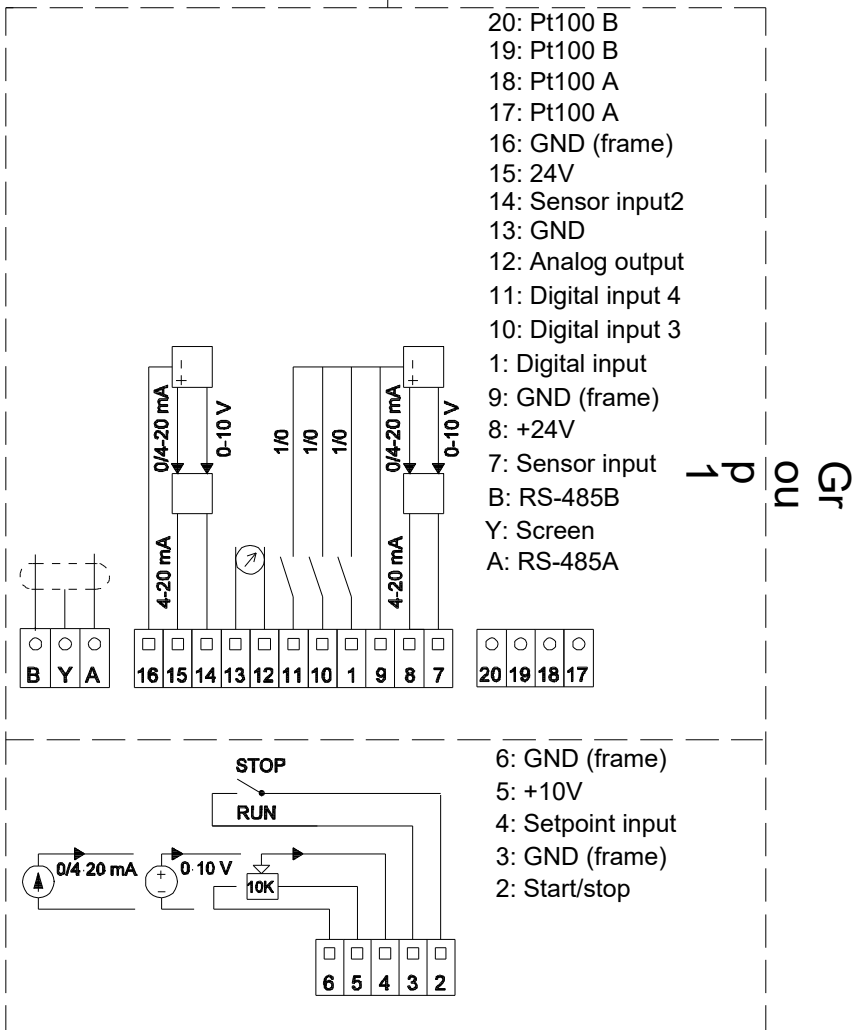
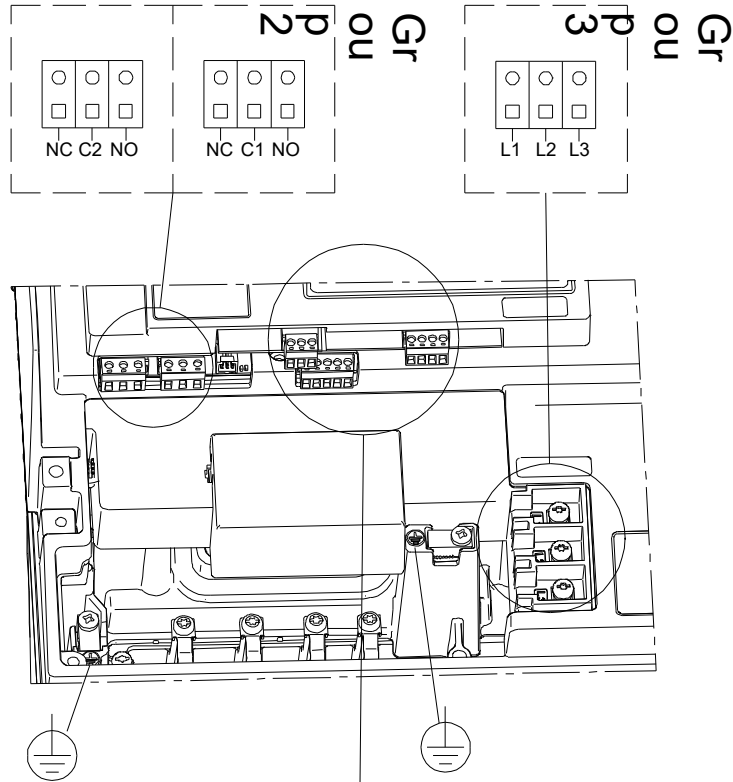

Note! All units are in [in] unless others are stated.