

PROJECT: _____	UNIT TAG: _____	QUANTITY: _____
REPRESENTATIVE: _____	TYPE OF SERVICE: _____	DATE: _____
ENGINEER: _____	SUBMITTED BY: _____	DATE: _____
CONTRACTOR: _____	APPROVED BY: _____	DATE: _____
	ORDER NO.: _____	DATE: _____



## CRE 125-2-2 N-G-A-E-HQQE

Vertical, multistage centrifugal pump with integrated frequency converter. The pump head and base are in cast iron - all other wetted parts are in stainless steel (EN 1.4301)

Note! Product picture may differ from actual product

Conditions of Service		Pump Data		Motor Data	
Liquid:	Water	Liquid temperature range:	-4 .. 248 °F	Rated power - P2:	30 HP
Temperature:	68 °F	Maximum ambient temperature:	104 °F	Rated voltage:	460 V
Specific Gravity:	1.000	Shaft seal:	HQQE	Mains frequency:	60 Hz
		Product number:	99266509	Enclosure class:	IP55
				Insulation class:	F
				Motor protection:	YES
				Motor type:	180AA
				Eta 1/1:	91.7 %

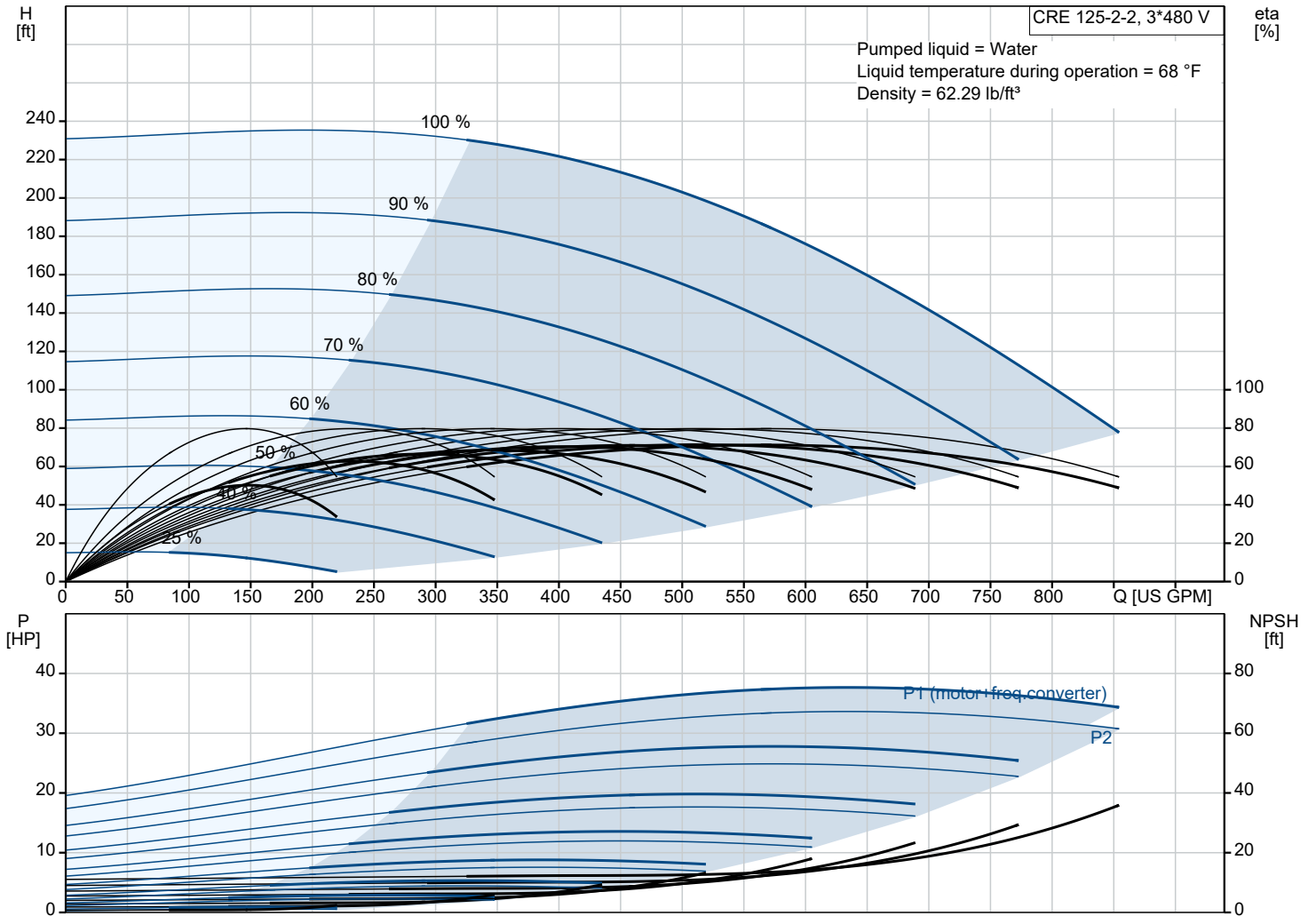

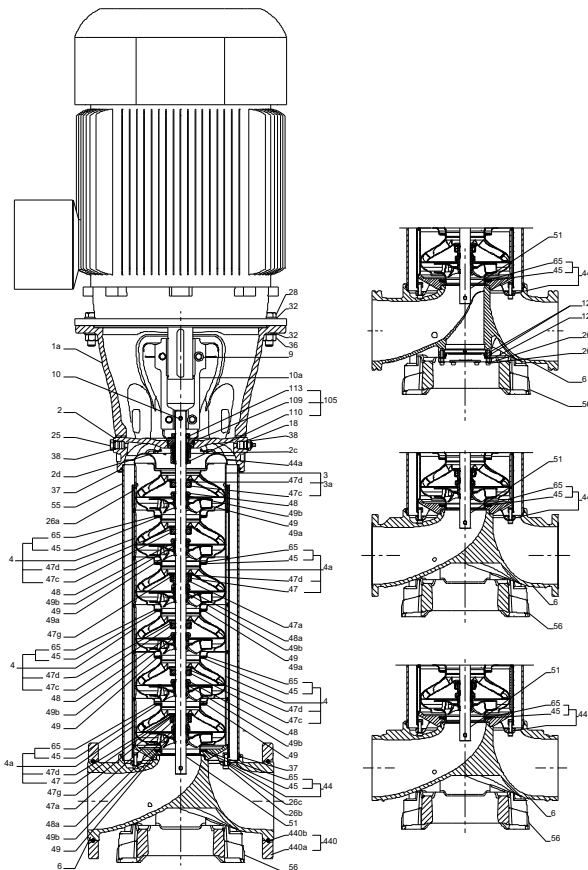
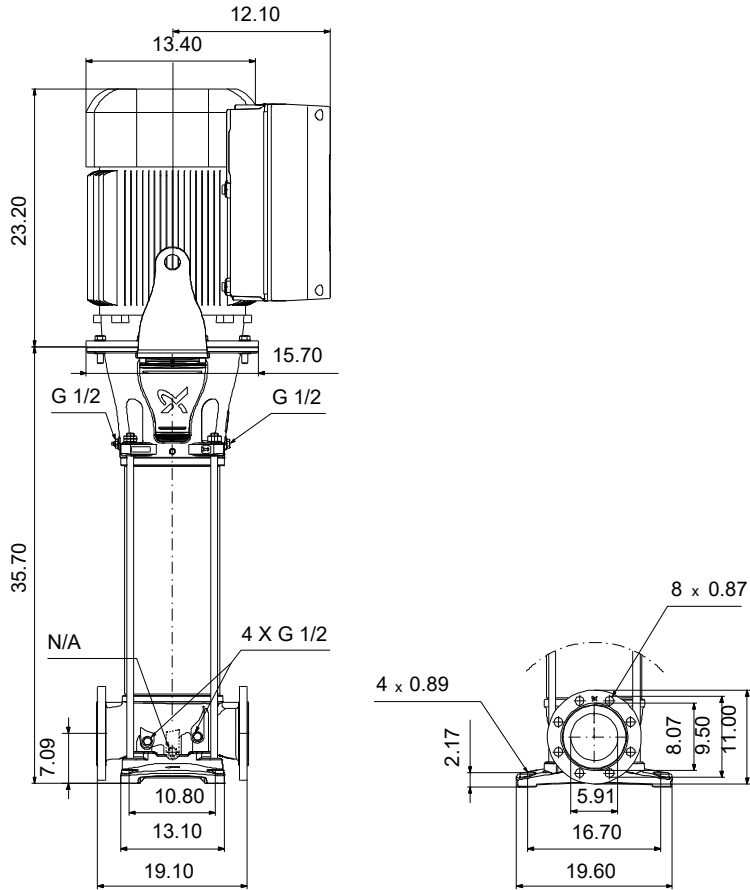

**Materials:**

- Base: Ductile cast iron
- Base: EN 1563 EN-GJS-500-7
- Base: ASTM A536-84 65-45-12
- Impeller: Stainless steel
- Impeller: AISI 304
- Impeller: EN 1.4301
- Material code: A
- Code for rubber: E

Qty.	Description
------	-------------

1 **CRE 125-2-2 N-G-A-E-HQQE**



**Note! Product picture may differ from actual product**

Product No.: [99266509](#)

Vertical, multistage centrifugal pump with inlet and outlet ports on same the level (inline). The pump head and base are in cast iron – all other wetted parts are in stainless steel. The Grundfos cartridge shaft seal ensures high reliability, safe handling, and easy access and service. Power transmission is via a rigid split coupling. Pipe connection is via ANSI flanges.

The pump is fitted with a 3-phase, fan-cooled asynchronous motor.

The motor includes a frequency converter and PI controller in the motor terminal box. This enables continuously variable control of the motor speed, which again enables adaptation of the performance to a given requirement.

An operating panel on the motor terminal box enables setting of required setpoint as well as setting of pump to "Min." or "Max." operation or to "Stop". The operating panel has indicator lights for "Operation" and "Fault".

Communication with the pump is possible by means of Grundfos GO Remote (accessory). The remote control enables further settings as well as reading out of a number of parameters such as "Actual value", "Speed", "Power input" and total "Power consumption".

The terminal box holds terminals for these connections:

- pump start/stop input (potential-free contact)
- remote setpoint setting via analog signal, 0-10 V, 0(4)-20 mA
- 10 V voltage supply for setpoint potentiometer, I<sub>max</sub> = 5 mA
- three analog sensor inputs, 0-10 V, 0(4)-20 mA; the factory-fitted pressure sensor is connected to one of these inputs
- 24 V voltage supply for sensor, I<sub>max</sub> = 40 mA
- one analog output
- three digital inputs
- two Pt100 inputs
- two potential-free fault signal relays with changeover contact, reporting "Fault", "Operation" or "Ready"
- RS-485 GENIbus connection
- interface for Grundfos CIM fieldbus module.

Liquid:

Pumped liquid: Water  
 Liquid temperature range: -4 .. 248 °F  
 Selected liquid temperature: 68 °F  
 Density: 62.29 lb/ft<sup>3</sup>

Technical:

Pump speed on which pump data are based: 3522 rpm  
 Rated flow: 660 US GPM  
 Rated head: 154.9 ft  
 Actual impeller diameter: 6.38 in  
 Pump orientation: Vertical  
 Shaft seal arrangement: Single  
 Code for shaft seal: HQQE  
 Approvals: CE  
 Approvals for drinking water: NSF/ANSI 61, NSF/ANSI 372  
 Curve tolerance: ISO9906:2012 3B

Materials:

Base: Ductile cast iron  
 EN 1563 EN-GJS-500-7  
 ASTM A536-84 65-45-12  
 Impeller: Stainless steel  
 EN 1.4301  
 AISI 304  
 Bearing: WC/WC  
 Support bearing: Graflon  
 Material certified according to: European standards

Installation:

t max amb: 104 °F  
 Maximum operating pressure: 232.06 psi

Qty.	Description
	<p>Max pressure at stated temp: 232 psi / 250 °F</p> <p>Type of connection: ANSI</p> <p>Size of inlet connection: 6 inch</p> <p>Size of outlet connection: 6 inch</p> <p>Pressure rating for connection: 150 lb</p> <p>Flange size for motor: 286TC</p> <p>Electrical data:</p> <p>Motor standard: NEMA</p> <p>Motor type: 180AA</p> <p>IE Efficiency class: NEMA Premium / IE3 60Hz</p> <p>Rated power - P2: 30 HP</p> <p>Power (P2) required by pump: 30 HP</p> <p>Mains frequency: 60 Hz</p> <p>Rated voltage: 3 x 460 V</p> <p>Service factor: 1.15</p> <p>Rated current: 36.5 A</p> <p>Cos phi - power factor: 0.88</p> <p>Rated speed: 480-3540 rpm</p> <p>Efficiency: IE3 91,7%</p> <p>Motor efficiency at full load: 91.7 %</p> <p>Number of poles: 2</p> <p>Enclosure class (IEC 34-5): IP55</p> <p>Insulation class (IEC 85): F</p> <p>Motor No: 85901139</p> <p>Controls:</p> <p>Frequency converter: Built-in</p> <p>Pressure sensor: Y</p> <p>Others:</p> <p>DOE Pump Energy Index VL: 0.59</p> <p>Net weight: 693 lb</p> <p>Gross weight: 957 lb</p> <p>Shipping volume: 44.2 ft³</p> <p>Thrust handling device: N</p>

# 99266509 CRE 125-2-2 N-G-A-E-HQQE 60 Hz

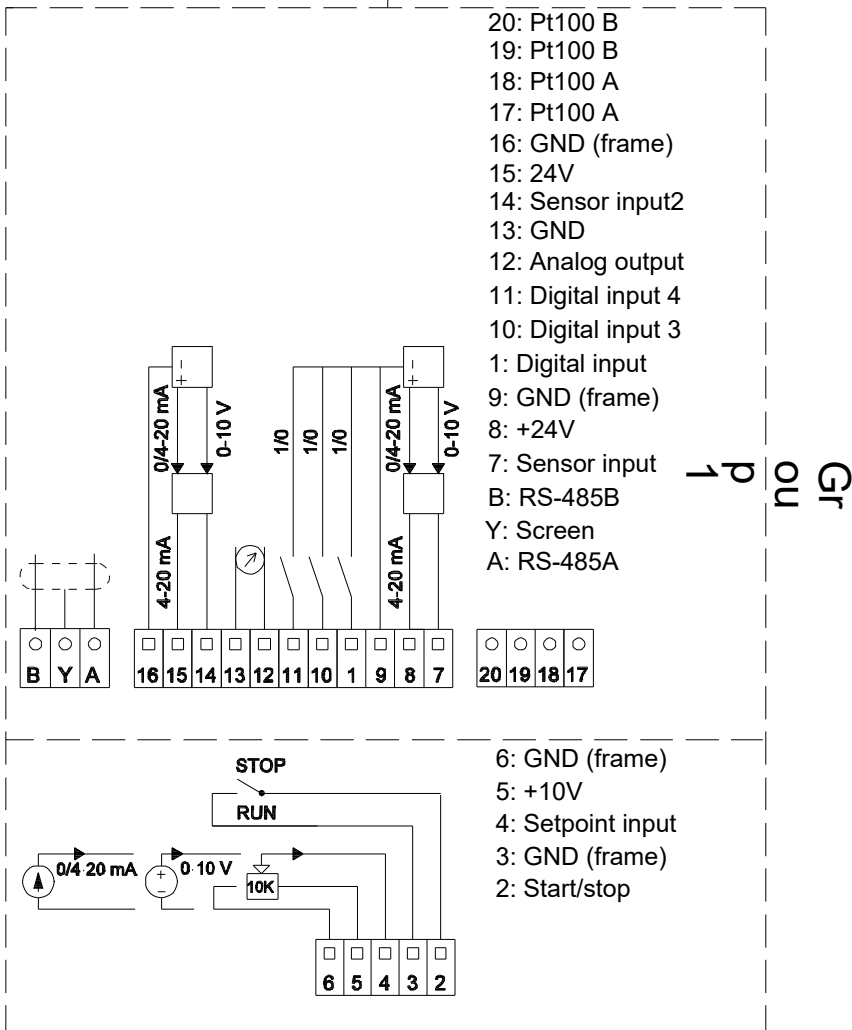
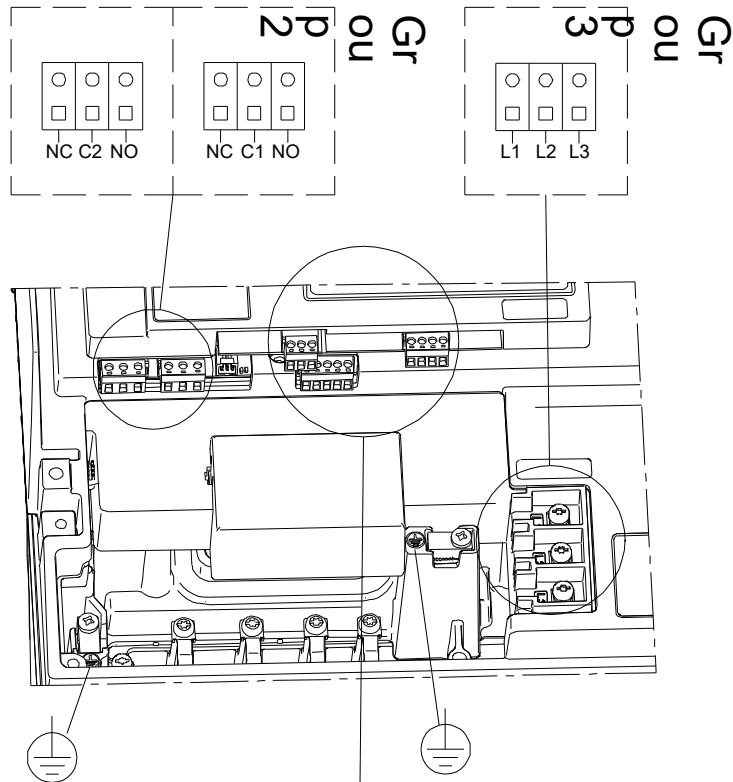

Note! All units are in [in] unless others are stated.