

ENCAUSTIC CEMENT

	USAGE
interior floor & wall	Y
exterior floor & wall	Y *
residential low traffic	Y
residential high traffic	Y
commercial low traffic	Y
commercial high traffic	Y
radiant heating compatible	Y
fireplace surround	Y
shower	Y
steam shower (resealing yearly)	Y
fountain	N
freeze thaw	N
pool	N
heat resistant	N **
backsplash	Y
grout type	flexcolor cq
grout joint size	1/16"
UV resistant	N ***

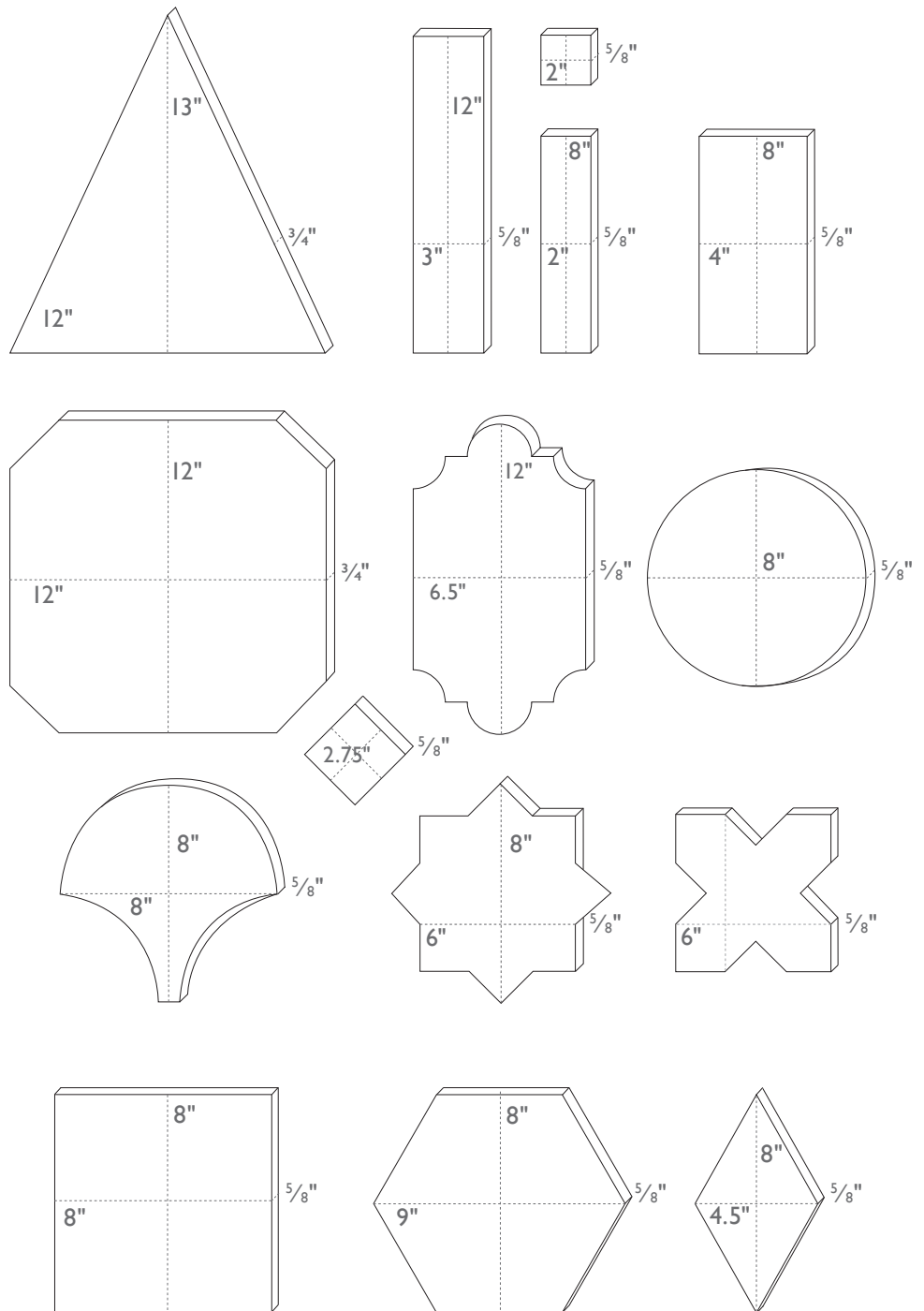

standard thickness for cement under 12" x 12" is 5/8". Standard thickness for cement over 12" x 12" is 3/4". Please note thickness can vary plus or minus 1/4".

- * Non freeze/thaw locations only. Exterior walls require vertical weather flashing and waterproof, penetrating sealant. Exterior floors must be installed above grade with waterproof, penetrating sealant.
- ** If installing near something very hot like a pizza oven (on a wall or backsplash) there must be at least a 6" space between the tile and oven.
- *** All colors will fade in direct sunlight over time. Black, dark blue, purple and green colors will fade faster than other colors.



ENCAUSTIC CEMENT INSTALLATION

What's in our tile: Our encaustic cement tiles do not use kilns or other firing processes, therefore no fossil fuels are burned during production. Instead they are processed in a way that allows them to be free of energy costs involved in the firing process of ceramic tiles. They are created using basic earth components—natural pigments mixed with ground marble dust, white portland cement and sand. Instead of firing, our cement tiles are made by pouring the materials into a mold, then hydraulically pressed and stacked in a water bath to cure. The end result is a durable, safe and long lasting tile.

clé has worked with our studios to provide the finest quality cement tiles available. However, for the best installation, it is important that you hire the highest qualified cement tile contractor for your project.

YOUR TILE INSTALLATION IS ONLY AS GOOD AS YOUR INSTALLER.

INSPECTING YOUR SHIPMENT

- Due to the color and shade variations, it is very important to blend the tiles from all boxes once they arrive and place them in their installation area to ensure you have the layout you want before installing.
- Industry standard suggests adding at least 15% overage due to tile cuts, potential breakage, or future repairs.
- Irregular or chipped edges and cracked surfaces is normal.
- Dust and residue from shipping should be cleaned prior to installing.

FOR INSTALLATION GUIDELINES

- clé's guides are only to help direct you in the right path for a proper installation. Each project is unique and therefore requires a professional with cement or natural stone installation experience who can provide the exact specifications for your project.
- Please refer to the current edition of the TCNA Handbook for best installation results.
- Tile is merely the surface of your construction. Installation problems will arise from substrate or construction engineering and/or installation issues. Please refer to your project architect, structural engineer and/or installer to have the best results for your tile finish.
- As is standard in the tile industry, installation deems acceptance of materials. Do not install if there are visible issues. If you have any doubts or are unsure of what qualifies as a visible issue for the tile you are installing, please reach out to us prior to installation. Our tiles are subject to variations in color, texture, size and finish. Do not install if you have any doubts about visible issues. Misuse by contractor or end-user including but not limited to negligence, physical and/or chemical abuse is not covered by clé's warranty.
- **IMPORTANT:** Before installing, make sure to lay out your tile and blend so that variations in color are where you would like them to be and are evenly distributed throughout the installation. Do not install without blending tiles from all boxes.
- To ensure proper bonding when setting, we recommend lightly wiping the back of each tile if there is excessive dust.
- Be sure to have 95% or more adhesive on the back of the tile to ensure the best bond when setting tiles 8" x 8" or larger.
- **IMPORTANT:** Cement tiles are not freeze thaw rated on their own.*

* Installations in freeze/thaw locations require flashing the top of vertical installations to prevent moisture from dripping behind the installation and installing the tiles above grade for horizontal installations. In addition, the installation must be completely sealed and maintained with a waterproof sealant like Miracle 511 Porous Plus (see manufacturer's instructions)—if cement is left unsealed it will experience freeze/thaw issues.

With application of Miracle Sealant, these tiles have resistance to freeze/thaw issues. However, we can't guarantee the installation will be done per our recommendations. If these basic procedures aren't followed, the installation will risk failing freeze/thaw.

For installation support we recommend your contractor reach out to both Mapei tech support and Miracle Sealant tech support on the waterproofing and maintenance of the tiles.

GROUT GUIDELINES

- clé ONLY recommends [Mapei Flexcolor CQ](#) grout for cement tile installations.
- Use of any other grout types can result in installation issues.
- Recommended grout joint size— $\frac{1}{16}$ "
- Ultracolor Plus FA should be used for extremely tight grout joints like with the 2"x2" mounted cement as it's made of a fine aggregate that is able to go in between the tight joints easier than Flexcolor CQ. If using Ultracolor Plus FA, which is intended for glazed tile, make sure to still apply a grout release or sealant prior to grouting to avoid the risk of staining/grout haze. The application of a grout release or sealant is advantageous where a fine surface porosity might trap the fine particles or color pigments. Please make sure to follow the [Mapei Ultracolor Plus FA application and cleanup instructions](#).
- Grout color selection is always up to our client and/or their design professional. However, clé is often asked for our opinion on best grout selections for our tiles. And due to the large array of grout colors that are now available, clé would like to offer this general guideline on a foolproof grout color selection for any of your clé tiles.
 - First, have your professional tile contractor complete your tile installation, except for the grout portion.
 - Next, when ready to grout, ask your contractor to bring ALL grout color charts from his preferred grout manufacturers, for your review.
 - Lastly, choose a time of day when you are most pleased with the lighting in your space (either natural lighting, installed lighting or a blend of both). During that lighting and time of day, select the grout color that best matches your tile selection.
- Note that the full Mapei Flexcolor CQ color catalogue contains 40 colors to choose from. Visit the [Mapei website](#) to view.
- If you are working with a patterned cement tile, highly color-variegated tile or a combination of tiles (checkered or otherwise), we recommend that you follow the above recommendations—but match your grout to the color in your pattern, varied tile or tile combination that you would most like to accentuate.
- Grout staining is only a problem if the guidelines set for Flexcolor CQ by Mapei aren't followed properly.

- Please make sure to follow the Mapei Flexcolor CQ [application and cleanup instructions](#) to avoid the risk of staining/grout haze and to allow for easy application and cleanability. Read all installation instructions thoroughly before use. Using consistent application procedures will produce consistent results. Some of these procedures include:
 - During grout application, immediately remove any excess grout off the face of the tile with a clean, damp cloth/sponge.
 - Use a “clean as you go” approach to spreading and washing the grout, to ensure that cleaning begins before the grout skins over and dries on the tile surface.
 - Grout small areas of between 30 to 40 sq. ft. (2.79 to 3.72 m²) at a time, so that cleaning can begin before the grout skins over and dries on the tile surface.
 - Change your water bucket frequently to prevent the development of a haze on the tile surface.
- Should your contractor choose to use another brand of grout other than Mapei Flexcolor CQ, be aware that the dyes used to pigment most grouts will stain cement tile.
- If your contractor selects brands other than Mapei grout or Miracle sealant, please have them reach out to the respected representatives of those manufactures for advice and support on failures.
- For any issues or questions regarding this grout, please reach out to Mapei directly at 1-800-992-6273 as they are the best and fastest line of resolution.

MAINTENANCE &
SEALING GUIDELINES

- **IMPORTANT:** Due to the porous nature of cement, all applications (dry and wet) must be sealed before and after grouting.
- Grout lines and the tile surface must be sealed as the final step of installation.
- clé only recommends the use of [Miracle 511 Porous Plus](#) for an invisible sealant finish.
- For areas of excessive wear and tear—residential high traffic floors, kitchens, busy bathroom floors or areas susceptible to grease build up etc.—we recommend three to five coats of [Miracle Mira Matte](#) in addition to sealing.
- If you are installing cement on a busy kitchen backsplash where heavy staining is a concern, we recommend applying the [clé top coat kit](#) to the tile surface and grouted areas instead of using Miracle 511 Porous Plus. The clé top coat kit can provide even more protection against stains on backsplashes. Apply the top coat kit as the final step of installation.
- Single coat reapplication of the penetrating sealant is required once a year in shower applications due to the continuous exposure to water.
- For superior water repellency in steam showers, we recommend applying Miracle 511 Impregnator in addition to Miracle 511 Porous Plus.
- For showers, opening windows/doors to help some of the moisture dissipate faster after use will help rid extra moisture.
- Topical sealants will require periodic stripping and re-application of sealant—please refer to a professional for this.
- If your contractor is having any issues or questions regarding this sealant, please have them reach out to Miracle tech support directly at 1-877-385-8155 as they are the best and fastest line of resolution.
- PLEASE FOLLOW ALL MIRACLE SEALANT INSTRUCTIONS FOR BEST RESULTS as well as MAINTENANCE UPKEEP RECOMMENDATIONS.*

* **HINT:** If water or oil does not bead up on the surface of your tiles then the sealant was not applied properly.

CLEANING
GUIDELINES

- Immediately clean up spills—do not allow liquids to sit on tile surface.
- Excess liquid can stain, pit and crack tile.
- Vacuum or sweep regularly—abrasive dirt and materials can scratch the surface.
- Non-slip mats or area rugs should be placed inside and outside entrance ways to remove abrasive materials that can scratch and dirty the tile surface.
- Mop floors regularly with warm, clean water and pH neutral cleaner.
- Interior wall installations can be cleaned with warm water and damp microfiber cloth.
- Shower and steam shower wall installations should be squeegeed after each use to prevent hard water stains, soap scum and mildew.
- Always avoid harsh chemicals and acidic or alkaline products.
- Grout lines can be cleaned with warm water and a soft bristled cleaning brush.
- Most stains can be removed with a pH neutral dish soap, hot water and the scrub side of a sponge.
- clé recommends the use of Miracle Porcelain & Ceramic Tile Cleaner to remove stubborn stains, grease build up, soap scum, hard water deposits and everyday grime.
- Miracle Tile & Stone Cleaner is effective as an ongoing maintenance cleaner and is gentle for everyday use.
- Oil stains are difficult to remove from cement. They will require the use of a poultice, like Miracle Sealants Poultice Plus to draw out the stain.
- For deep cleaning of larger surfaces we recommend Miracle Liquid Poultice. Like the Poultice Plus, this cleaner draws the stains to the surface to be rinsed away.
- For heavily soiled surfaces we recommend Miracle Heavy-Duty Cleaner Acid Substitute—an industrial cleaner that's water-based and safe for cement tiles. Capable of removing grease, dirt and other stains.
- Follow the manufacturer's instructions for application and use.

CEMENT
RESTORATION

One of the biggest assets of using cement tile instead of ceramic tiles, is their ability to be refinished like hardwood floors. This isn't the case for lesser quality cement tiles, but your clé cement tile purchase ensures that you not only have the highest quality cement tiles, but your tiles will also be able to be renewed when needed.

Extremely heavy foot traffic or outdoor installations may require refinishing. clé only recommends using a licensed tile and stone restoration company for this type of work.