

ENCAUSTIC CEMENT

USAGE	Y/N
interior floor	Y*
interior wall	Y*
exterior floor	Y*
exterior wall	Y*
residential heavy traffic	Y
commercial heavy traffic	Y
radiant heating compatible	Y
fireplace surround	Y
shower	Y*
steam shower	Y*
fountain	N
freeze thaw	N
pool	N
heat resistant	N
sink backsplash	Y*
stove backsplash	Y*
grout type	flexcolor cq
grout joint size	1/16"
UV resistant	N

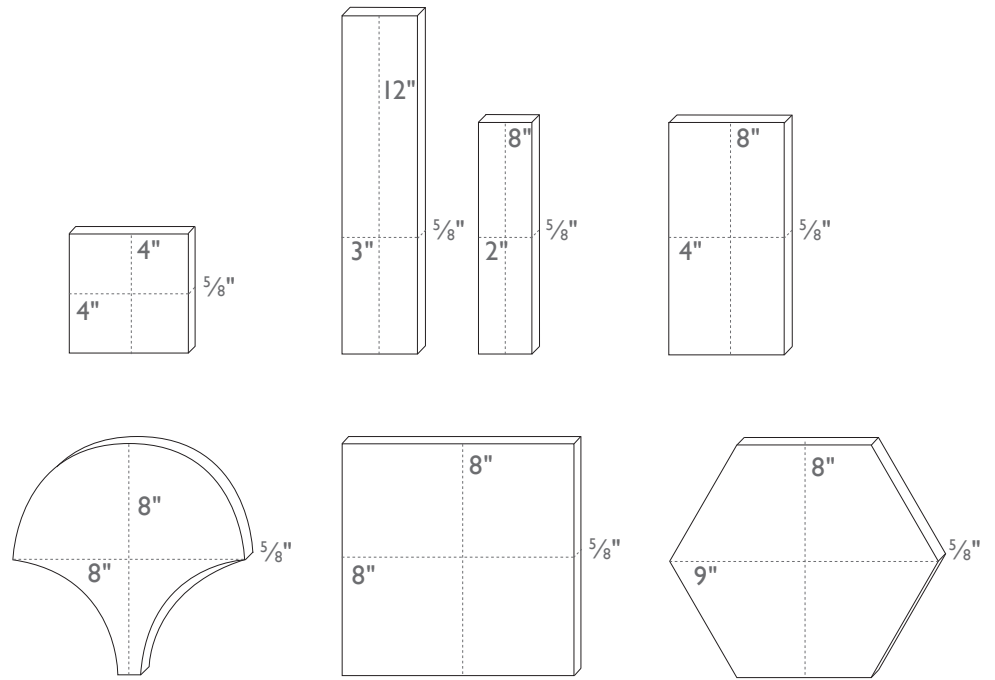

Made to order sizes:

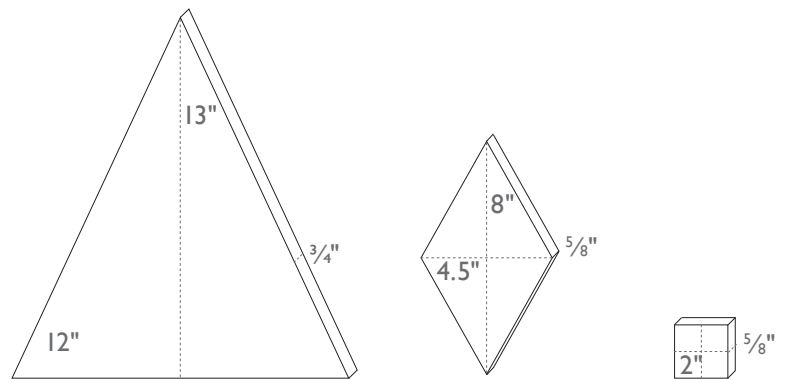

Standard thickness for cement under 12" x 12" is 5/8". Standard thickness for cement over 12" x 12" is 3/4". Please note thickness can vary +/- 1/4".

* There are specific installation requirements for this usage, read more information under the installation, sealing, grout, and wet area application sections of this document.

CEMENT RESOURCES—TRADE

INSPECTING YOUR SHIPMENT

- **IMPORTANT:** Due to the color and shade variations found in cement tiles, it is very important to blend the tiles from all boxes once they arrive and place them in their installation area to ensure you have the layout you want before installing.
- Dust and shipping residue* are to be expected and should be cleaned prior to installing.
- Irregular or chipped edges and cracked surfaces are also to be expected and normal.
- Industry standard suggests adding at least 15% overage due to tile cuts, potential breakage, or future repairs.

- * **NOTE:** Smudging caused by friction during shipping, and clouding of the tile surface where the pre-application of sealant has humidified are uncommon, but these issues can sometimes occur.
 - Smudging tends to be more common/ noticeable on contrasting black and white patterned tiles.
 - In general, our recommended 15% overage should cover any smudging or clouding found within an order. Smudging or clouding can occur on cement tiles but generally comes off by itself during the installation process. If needed, the tiles can easily be sanded down by hand with 400 grit sandpaper to fully remove these marks prior to grouting/sealing.
 - All of our cement tiles have a pigment layer that is roughly 1/8" thick, so sanding will ONLY effectively remove the top-most micro-layer of the tile surface to access the fresh pigment underneath.
 - Cement tiles are traditionally not packaged with a sheet of paper or styrofoam between them as the tiles are generally still moist from production; during shipping, if packed with paper this moisture can turn to mold—or if packed with styrofoam, this can act as a moisture trap and contribute to clouding.

INSTALLATION

- As is standard in the tile industry, installation deems acceptance of materials. Do not install if there are visible issues. If you have any doubts or are unsure of what qualifies as a visible issue for the tile you are installing, please reach out to us prior to installation. Our tiles are subject to variations in color, texture, size and finish. Do not install if you have any doubts about visible issues. Misuse by contractor or end-user including but not limited to negligence, physical and/or chemical abuse is not covered by clé's warranty.
- Tile is merely the surface of your construction. Installation problems will arise from substrate or construction engineering and/or installation issues. Please refer to your project architect, structural engineer and/or installer to have the best results for your tile finish.
- clé's guides are only to help direct you in the right path for a proper installation. Each project is unique and therefore requires a professional who can provide the exact specifications for your project.
- Please refer to the current edition of the TCNA Handbook for best installation results and ANSI A137.1 American National Standard Specifications for Ceramic Tile to reference for specifications.
- **IMPORTANT:** Before installing, make sure to lay out your tile and blend so that variations in color are where you would like them to be and are evenly distributed throughout the installation. Do not install without blending tiles from all boxes.

- To ensure proper bonding when setting, we recommend lightly wiping the back of each tile if there is excessive dust.
- Be sure to have 95% or more adhesive on the back of the tile to ensure the best bond when setting tiles 8" x 8" or larger.
- DO NOT USE TAPE during product installation, or otherwise. We cannot guarantee our products' safety against various construction tapes—INCLUDING BLUE TAPE.
- All colors will fade in direct sunlight over time. Black, dark blue, purple and green colors will fade faster than other colors.

SEALANT

- Grout lines and the tile surface must be sealed as the final step of installation.
 - We only recommend the use of [Miracle 511 Porous Plus](#) for an invisible, water and stain resistant seal.
 - For heavy traffic commercial installations or areas susceptible to grease build-up we recommend three to five coats of [Miracle Mira Matte](#) top-coat sealant in addition to sealing.
 - If you are installing cement on a busy kitchen backsplash where heavy staining is a concern, we recommend applying the [clé top coat kit](#) to the tile surface and grouted areas instead of using Miracle 511 Porous Plus. The clé top coat kit can provide even more protection against stains on backsplashes. Apply the top coat kit as the final step of installation.
 - For steam showers we recommend applying Miracle 511 Impregnator sealant in addition to 511 Porous Plus for superior water repellency.
 - Always test sealers in a small area to ensure it provides the finish you prefer.
 - Some grouts require applying sealant or grout release before grouting. Read more information under grout and staining sections in this document.
 - If your contractor is having any issues or questions regarding this sealant, please have them reach out to Miracle directly, as they are the best and fastest line of resolution.
 - PLEASE FOLLOW ALL MIRACLE SEALANT INSTRUCTIONS FOR BEST RESULTS as well as MAINTENANCE UPKEEP RECOMMENDATIONS.*
- * **HINT:** If water and oil do not bead up on the surface of your tiles then the sealant was not applied properly.

GROUT

- clé ONLY recommends [Mapei Flexcolor CQ](#) grout for cement tile installations.
- Use of any other grout types can result in installation issues.
- Recommended grout joint size— $\frac{1}{16}$ "
- Ultracolor Plus FA should be used for extremely tight grout joints like with the 2" x 2" mounted cement as it's made of a fine aggregate that is able to go in between the tight joints easier than Flexcolor CQ. If using Ultracolor Plus FA, which is intended for glazed tile, make sure to still apply a grout release or sealant prior to grouting to avoid the risk of staining/grout haze. The application of a grout release or sealant is advantageous where a fine surface porosity might trap the fine particles or color pigments. Please make sure to follow the [Mapei Ultracolor Plus FA application and cleanup instructions](#).

- Grout color selection is always up to our client and/or their design professional. However, clé is often asked for our opinion on best grout selections for our tiles. And due to the large array of grout colors that are now available, clé would like to offer this general guideline on a foolproof grout color selection for any of your clé tiles.
 - First, have your professional tile contractor complete your tile installation, except for the grout portion.
 - Next, when ready to grout, ask your contractor to bring ALL grout color charts from his preferred grout manufacturers, for your review.
 - Lastly, choose a time of day when you are most pleased with the lighting in your space (either natural lighting, installed lighting or a blend of both). During that lighting and time of day, select the grout color that best matches your tile selection.
- Note that the full Mapei Flexcolor CQ color catalogue contains 40 colors to choose from. Visit the [Mapei website](#) to view.
- If you are working with a patterned cement tile, highly color-variegated tile or a combination of tiles (checkered or otherwise), we recommend that you follow the above recommendations—but match your grout to the color in your pattern, varied tile or tile combination that you would most like to accentuate.
- If your contractor is having any issues or questions regarding this grout, please reach out to Mapei directly at 1-800-992-6273 as they are the best and fastest line of resolution.

STAINING

- Grout staining is only a problem if the guidelines set for Flexcolor CQ by Mapei aren't followed properly.
- Please make sure to follow the Mapei Flexcolor CQ [application and cleanup instructions](#) to avoid the risk of staining/grout haze and to allow for easy application and cleanability. Read all installation instructions thoroughly before use. Using consistent application procedures will produce consistent results. Some of these procedures include:
 - Dampen the tile prior to grouting as an aid to spreading the grout and cleaning.
 - During grout application, immediately remove any excess grout off the face of the tile with a clean, damp cloth/sponge.
 - Use a “clean as you go” approach to spreading and washing the grout, to ensure that cleaning begins before the grout skins over and dries on the tile surface.
 - Grout small areas of between 30 to 40 sq. ft. (2.79 to 3.72 m²) at a time, so that cleaning can begin before the grout skins over and dries on the tile surface.
 - Change your water bucket frequently to prevent the development of a haze on the tile surface.
- Should your contractor choose to use another brand of grout other than Mapei Flexcolor CQ, be aware that the dyes used to pigment most grouts will stain cement tile.
- If your contractor selects brands other than Mapei grout or Miracle sealant, please have them reach out to the respected representatives of those manufactures for advice and support on failures.

EXTERIOR
INSTALLATIONS

- **IMPORTANT:** Cement tiles are not freeze thaw rated on their own.*

* Installations in freeze/thaw locations require flashing the top of vertical installations to prevent moisture from dripping behind the installation and installing the tiles above grade for horizontal installations. In addition, the installation must be completely sealed and maintained with a weather resistant sealant like Miracle 511 Porous Plus (see manufacturer's instructions)—if cement is left unsealed it will experience freeze/thaw issues.

With application of Miracle Sealant, these tiles have resistance to freeze/thaw issues. However, we can't guarantee the installation will be done per our recommendations. If these basic procedures aren't followed, the installation will risk failing freeze/thaw.

For installation support we recommend your contractor reach out to both Mapei tech support and Miracle Sealant tech support on the waterproofing and maintenance of the tiles.

MAINTENANCE

- Over time, a natural patina will occur on floors as they are maintained and naturally wear.
- Topical sealants will require periodic stripping and re-application of sealant—please refer to a professional for this.
- Single coat reapplication of the penetrating sealant is required once a year in shower applications due to the continuous exposure to water.
- Reapplication is needed more often if installation is in a steam shower. Please refer to a professional for this.
- For superior water repellency in steam showers, we recommend applying Miracle 511 Impregnator in addition to Miracle 511 Porous Plus.
- For steam showers, opening windows/doors to help some of the moisture dissipate faster after use will help rid extra moisture.
- Check with the Miracle Sealant tech support directly at 1-877-385-8155 for best advice on applying and maintaining sealants.

CLEANING

- Immediately clean up spills—do not allow liquids to sit on tile surface. Excess liquid can stain, pit and crack tile.
- Vacuum or sweep regularly—abrasive dirt and materials can scratch the surface.
- Non-slip mats or area rugs should be placed inside and outside entrance ways to remove abrasive materials that can scratch and dirty the tile surface.
- Mop floors regularly with warm, clean water and pH neutral cleaner.
- Interior wall installations can be cleaned with warm water and damp microfiber cloth.
- Shower and steam shower wall installations should be squeegeed after each use to prevent hard water stains, soap scum and mildew.
- Always avoid harsh chemicals and acidic or alkaline products.
- Grout lines can be cleaned with warm water and a soft bristled cleaning brush.
- Most stains can be removed with a pH neutral dish soap, hot water and the scrub side of a sponge.
- clé recommends the use of Miracle Porcelain & Ceramic Tile Cleaner to remove stubborn stains, grease build up, soap scum, hard water deposits and everyday grime.
- Miracle Tile & Stone Cleaner is effective as an ongoing maintenance cleaner and is gentle for everyday use.

- Oil stains are difficult to remove from cement. They will require the use of a poultice, like Miracle Sealants Poultice Plus to draw out the stain.
- For deep cleaning of larger surfaces we recommend Miracle Liquid Poultice. Like the Poultice Plus, this cleaner draws the stains to the surface to be rinsed away.
- For heavily soiled surfaces we recommend Miracle Heavy-Duty Cleaner Acid Substitute—an industrial cleaner that’s water-based and safe for cement tiles. Capable of removing grease, dirt and other stains.
- Follow the manufacturer's instructions for application and use.

CEMENT
RESTORATION

- Extremely heavy foot traffic or outdoor installations may require refinishing.
- Should your cement tile installation start to show signs of staining, distressing and/or wear and tear, they can be refinished—similar to how stone and hardwood floors can be refinished to renew the surface.
- Wet sanding should be performed by a proficient handy person or floor refinisher.
- The colored top layer of cement tiles are very hard and can withstand periodic refinishing.
- When followed correctly, the result will be a gentle removal of a mirco-layer exposing a like-new pigment surface.

The following tips should only be performed by licensed tile/stone refinishers

- Refinishing requires an orbital sander buffer with a 400 grit wet/sandpaper, two buckets of clean water & two clean towels.
- Find a test area and use one bucket and towel to douse water onto tile surface to act as a lubricant.
- Use the orbital sander to sand area, stopping and wiping the sanded tile with the other towel immediately until you have successfully removed micro-layer off of the top surface.
- **IMPORTANT:** You must immediately clean the resulting pigment slurry—failure to do this while sanding will result in grout/sanding slurry staining the surface of the tile.
- If test area is successful, proceed to sand the rest of the installation.
- Once you have successfully stripped the surface, you must reseal tiles using previous Miracle Sealant products and manufacturers instructions.

CEMENT TILE SPECIFICATIONS

What's in our tile: Our encaustic cement tiles do not use kilns or other firing processes, therefore no fossil fuels are burned during production. Instead they are processed in a way that allows them to be free of energy costs involved in the firing process of ceramic tiles. They are created using basic earth components—natural pigments mixed with ground marble dust, white portland cement and sand. Instead of firing, our cement tiles are made by pouring the materials into a mold, then being hydraulically pressed and stacked in a water bath to cure. The end result is a durable, safe and long lasting tile.

COLOR, TEXTURE AND SIZE VARIATION

Cement tiles are rated 'level 3 medium' for color variation, 'level 1 smooth' for texture variation, and 'level 1 slight' for size variation.

Due to the handmade craftsmanship of many of our tiles and the variety of materials used, there are degrees of variation in our tiles color, shade and texture. These differences are more pronounced in certain types of tiles than others, especially in tiles from separate production lots, or "batches".

The following is a guide for the different degrees of variation that we have assigned our tiles:

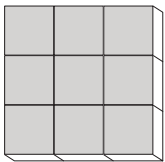
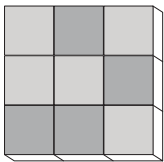
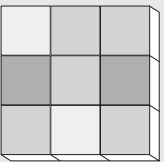
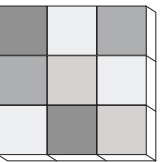
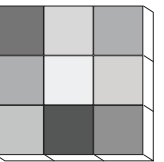
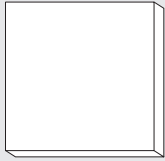
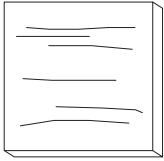
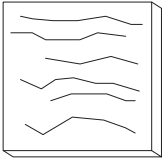
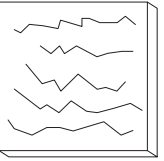
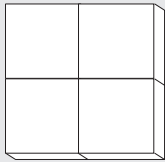
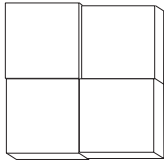
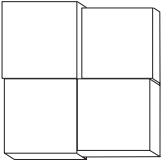
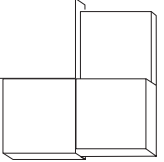
CATEGORY	LEVEL 1	LEVEL 2	LEVEL 3	LEVEL 4	LEVEL 5
COLOR VARIATION	 <p>low</p>	 <p>slight</p>	 <p>medium</p>	 <p>heavy</p>	 <p>extreme</p>
TEXTURE VARIATION	 <p>smooth</p>	 <p>slight</p>	 <p>medium</p>	 <p>heavy</p>	n/a
SIZE VARIATION	 <p>slight</p>	 <p>medium</p>	 <p>heavy</p>	 <p>extreme</p>	n/a

Imperfections

Cement tiles are rated 'level I light' for cracks/crazing.

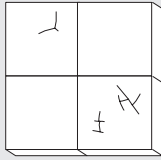
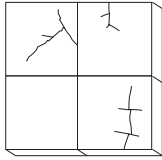
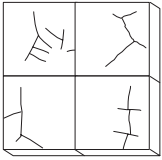
	LEVEL 1	LEVEL 2	LEVEL 3
CRACKS / CRAZING			

FLOOR RATING

Cement tiles are rated IV

(can be used for light residential to heavy commercial foot traffic)

I light residential

for residential areas with light foot traffic. examples can include bathroom, bedroom, formal dining and living rooms. please note the following:

- not suitable for shoes with hard sole profiles (cleats, stilettos, etc.)
- the floor must be kept clean from abrasive debris (gravel, mud, salt, etc.)
- immediately clean all stains (food, personal and household care products, oils, paints, chemicals etc.)

II heavy residential

for residential areas with continuous foot traffic. examples can include entry, hallway, kitchen, foyer, laundry and mud rooms. please note the following:

- the floor must be kept clean from abrasive debris (sand, gravel, mud, salt, etc.)
- immediately clean all stains (food, personal and household care products, oils, paints, chemicals etc.)

III light commercial

for commercial areas with light foot traffic. examples can include commercial office, doctor's office and boutique. please note the following:

- the floor must be kept clean from abrasive debris (sand, gravel, mud, salt, etc.)
- immediately clean all stains (food, personal and household care products, oils, paints, chemicals etc.)

IV heavy commercial

for commercial areas with continuous foot traffic. examples can include hotel lobby, retail, corridors in an office building, shopping mall and restaurant. please note the following:

- the floor must be kept clean from abrasive debris (sand, gravel, mud, salt, etc.)
- immediately clean all stains (food, personal and household care products, oils, paints, chemicals etc.)

V industrial

standard industrial floor use with no extreme, heavy breakage or spillage.

examples can include restaurant kitchen, bar work area, winery production, exterior hotel entry, airport, car showroom, driveway. please note the following:

- the floor must be kept clean from abrasive debris (sand, gravel, mud, salt, etc.)
- immediately clean all stains (food, personal and household care products, oils, paints, chemicals etc.)

PRODUCT DESCRIPTION	Hydraulic pressed handmade cement tiles.												
PRODUCT COMPONENTS	<p>Wear colored layer: 3 to 4 mm +/- thickness affixed to the tile body by 1,700 PSI mechanical pressure, composed of: white portland cement, marble dust and mineral pigments for color (oxides and organic)</p> <p>Tile Body: 12 mm +/- in thickness, composed of gray portland cement & sand</p> <p>Our cement tiles are made up of three different layers: Top layer = known as the 'color' and design layer made of natural pigments mixed with ground marble dust and the finest white portland cement. Middle layer = a mortar made of fine sand and portland cement that provides for compression reinforcement for heavy traffic and furniture. Bottom layer = solid concrete made to be strong and porous for impact strength before and after installation.</p>												
DIMENSIONS	<table border="1"> <tr> <td>Rectangle</td> <td>5 cm x 20 cm x 1.6 cm (2" x 8" x 5/8") / .34 kg per tile (.75 lb) 10 cm x 20 cm x 1.6 cm (4" x 8" x 5/8") / .68 kg per tile (1.5 lbs) 7.6 cm x 30.5 cm x 1.6 cm (3" x 12" x 5/8") / .77 kg per tile (1.7 lbs)</td> </tr> <tr> <td>Square</td> <td>5 cm x 5 cm x 1.6 cm (2" x 2" x 5/8") / .08 kg per tile (.18 lb) 10 cm x 10 cm x 1.6 cm (4" x 4" x 5/8") / .34 kg per tile (.75 lb) 20 cm x 20 cm x 1.6 cm (8" x 8" x 5/8") / 1.36 kg per tile (3 lbs)</td> </tr> <tr> <td>Diamond</td> <td>11 cm x 20 cm x 1.6 cm (4.5" x 8" x 5/8") / 1.36 kg per tile (3 lbs)</td> </tr> <tr> <td>Hexagon</td> <td>20 cm x 23 cm x 1.6 cm (8" x 9" x 5/8") / 1.36 kg per tile (3 lbs)</td> </tr> <tr> <td>Scallop</td> <td>20 cm x 20 cm x 1.6 cm (8" x 8" x 5/8") / .68 kg per tile (1.5 lbs)</td> </tr> <tr> <td>Triangle</td> <td>30 cm x 33 cm x 1.9 cm (12" x 13" x 3/4") / 1.59 kg per tile (3.5 lbs)</td> </tr> </table> <p>* Please note all dimensions are nominal and can vary +/- 1/4 inches.</p>	Rectangle	5 cm x 20 cm x 1.6 cm (2" x 8" x 5/8") / .34 kg per tile (.75 lb) 10 cm x 20 cm x 1.6 cm (4" x 8" x 5/8") / .68 kg per tile (1.5 lbs) 7.6 cm x 30.5 cm x 1.6 cm (3" x 12" x 5/8") / .77 kg per tile (1.7 lbs)	Square	5 cm x 5 cm x 1.6 cm (2" x 2" x 5/8") / .08 kg per tile (.18 lb) 10 cm x 10 cm x 1.6 cm (4" x 4" x 5/8") / .34 kg per tile (.75 lb) 20 cm x 20 cm x 1.6 cm (8" x 8" x 5/8") / 1.36 kg per tile (3 lbs)	Diamond	11 cm x 20 cm x 1.6 cm (4.5" x 8" x 5/8") / 1.36 kg per tile (3 lbs)	Hexagon	20 cm x 23 cm x 1.6 cm (8" x 9" x 5/8") / 1.36 kg per tile (3 lbs)	Scallop	20 cm x 20 cm x 1.6 cm (8" x 8" x 5/8") / .68 kg per tile (1.5 lbs)	Triangle	30 cm x 33 cm x 1.9 cm (12" x 13" x 3/4") / 1.59 kg per tile (3.5 lbs)
Rectangle	5 cm x 20 cm x 1.6 cm (2" x 8" x 5/8") / .34 kg per tile (.75 lb) 10 cm x 20 cm x 1.6 cm (4" x 8" x 5/8") / .68 kg per tile (1.5 lbs) 7.6 cm x 30.5 cm x 1.6 cm (3" x 12" x 5/8") / .77 kg per tile (1.7 lbs)												
Square	5 cm x 5 cm x 1.6 cm (2" x 2" x 5/8") / .08 kg per tile (.18 lb) 10 cm x 10 cm x 1.6 cm (4" x 4" x 5/8") / .34 kg per tile (.75 lb) 20 cm x 20 cm x 1.6 cm (8" x 8" x 5/8") / 1.36 kg per tile (3 lbs)												
Diamond	11 cm x 20 cm x 1.6 cm (4.5" x 8" x 5/8") / 1.36 kg per tile (3 lbs)												
Hexagon	20 cm x 23 cm x 1.6 cm (8" x 9" x 5/8") / 1.36 kg per tile (3 lbs)												
Scallop	20 cm x 20 cm x 1.6 cm (8" x 8" x 5/8") / .68 kg per tile (1.5 lbs)												
Triangle	30 cm x 33 cm x 1.9 cm (12" x 13" x 3/4") / 1.59 kg per tile (3.5 lbs)												
AVERAGE COEFFICIENT OF FRICTION (DCOF ACUTEST)	<p>"Wet Dynamic Coefficient of Friction" (DCOF)—avg. 0.74*</p> <p>* Application of Miracle 511 Porous Plus and/or Miracle 511 Impregnator can help increase slip resistance.</p>												
FREEZE/THAW RESISTANCE (ASTM C1026)	Cement tiles are not freeze/thaw resistant.												
WATER ABSORPTION (ASTM C373)	avg. 10.9%; non-vitreous												
ACID RESISTANCE	Cement tiles are not resistant to acids and should be cleaned with pH neutral cleaners.												

LEED CREDITS

The product is an inherently non-emitting source of VOCs (stone, ceramic, metals, powder-coated metals, plated or anodized metal, glass, cement, clay brick, and unfinished or untreated solid wood) and has no integral organic-based surface coatings, binders, or sealants.

Our cement tiles are considered 'inherently non-emitting sources' under the Low-emitting Materials Credit of LEEDv4/v4.1, but our current pre-seal offering is not compliant with LEED. Because we offer them finished in a pre-polish & pre-seal format to support stain resistance, we would recommend ordering them without the sealant, in the pre-polish format only, in order to qualify for the Low-emitting Materials Credit.

'Inherently non-emitting' means that these tiles types have been shown to not contribute emissions to indoor environments and are therefore exempt from demonstrating compliance with CDPH v1.1-2010 or CDPH v1.2-2017.

Use of these tiles as Wall or Flooring materials should be entered in the LEED v4.1 low-emitting materials Calculator and identified as 'inherently non-emitting' in the Products Tab (Column L).

Disclosures for MR Credit Material Ingredient Disclosures under LEEDv4/v4.1, are not available at this time. We are exploring our disclosure options and hope to have these available Q1/Q2 of 2020.

Disclosures for MR Credit Environmental Product Declarations under LEEDv4/v4.1, are not available at this time. We are exploring our disclosure options and have not established a timeline for completion.

Contribution to MR Credit Material Sourcing under LEEDv4/v4.1, does not apply as there is no recycled content, no bio-based materials, no wood, no reused products included in our tile at this time. Extended producer responsibility programs are highly difficult to manage given the nature of end-of-use tile removal methods. *Tile can last hundreds of years but fashions often change, which is the dominant reason for its removal. We work hard to ensure our cement tiles can withstand the tests of time while remaining timeless.*

RECYCLED CONTENT

There is no recycled content in our cement tiles at this time. See Material Sourcing disclosure above.

PERCENTAGE OF PRE-CONSUMER AND/OR POST-CONSUMER MATERIALS

There is no pre-consumer or post-consumer material content in our tiles at this time. See Material Sourcing disclosure above.

FIRE RATING

We currently do not have fire testing results for our cement tiles and are exploring our testing options.

WET AREA APPLICATION

Cement tiles can be installed on backsplashes, in bathrooms, showers and steam showers with application of a waterproof, penetrating sealant.

When installing, make sure these specific waterproofing precautions are taken:

- A waterproof membrane is used under the tile and a waterproof, penetrating sealer is used to seal the grouted areas and the tile surface. clé recommends Miracle Sealants 511 Porous Plus for this sealing.
- Single coat reapplication of the penetrating sealer is required once a year in shower applications due to the continuous exposure to water.
- Reapplication is needed more often if installation is in a steam shower.
- For superior water repellency in steam showers, we recommend applying Miracle 511 Impregnator in addition to Miracle 511 Porous Plus.
- Cement tiles are not suitable for pool or fountain use.