

FORNACE BRIONI GLAZED CERAMIC

USAGE	Y / N
interior floor & wall	N*
exterior floor & wall	N**
residential low traffic	N
residential high traffic	N
commercial low traffic	N
commercial high traffic	N
radiant heating compatible	Y
fireplace surround	Y
shower	Y
steam shower (resealing yearly)	Y
fountain	N
freeze thaw	N
pool	N
heat resistant	N***
backsplash	Y
grout type	ultracolor plus fa
grout joint size	1/8"
UV resistant	Y

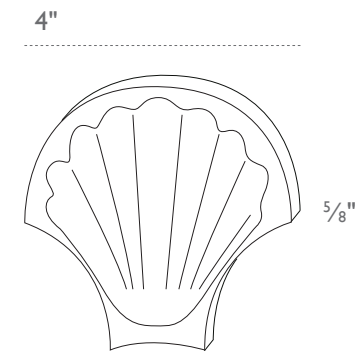
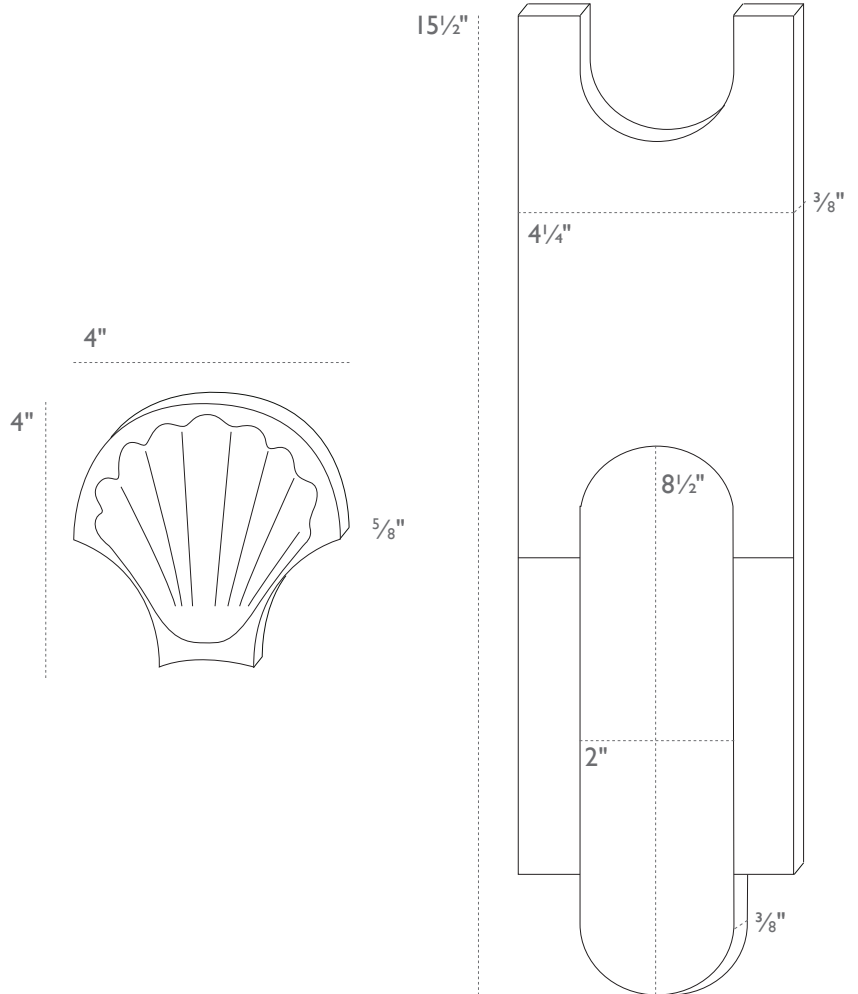

Standard thickness for Glazed Tivoli is 3/8" and 5/8" for Rocaille.
 Please note all dimensions are nominal and can vary plus or minus 1/8".

- * Wall use only, not suitable for floors.
- ** Can only be installed on exterior walls and requires vertical weather flashing at the top and application of waterproof, penetrating sealant. Non freeze/thaw locations only.
- *** If installing near something very hot like a pizza oven (on a wall or backsplash) there must be at least a 6" space between the tile and oven.



FORNACE BRIONI GLAZED CERAMIC—TRADE

INSPECTING YOUR SHIPMENT

- All Fornace Brioni tiles are made by hand, therefore slight variations in thickness, depth, color, shade and size to be expected.
- Due to the slight color and shade variations, it is very important to blend the tiles from all boxes once they arrive and place them in their installation area to ensure you have the layout you want before installing. Do not install without blending tiles from all boxes.
- Industry standard suggests adding at least 15% overage due to tile cuts, potential breakage, or future repairs.
- Dust and residue from shipping should be cleaned prior to installing. This can be done with a damp sponge or microfiber cloth.

INSTALLATION

- clé's guides are only to help direct you in the right path for a proper installation. Each project is unique and therefore requires a professional who can provide the exact specifications for your project.
- Please refer to the current edition of the TCNA Handbook for best installation results and ANSI A137.1 American National Standard Specifications for Ceramic Tile to reference for specifications.
- Tile is merely the surface of your construction. Installation problems will arise from substrate or construction engineering and/or installation issues. Please refer to your project architect, structural engineer and/or installer to have the best results for your tile finish.
- As is standard in the tile industry, installation deems acceptance of materials. Do not install if there are visible issues. If you have any doubts or are unsure of what qualifies as a visible issue for the tile you are installing, please reach out to us prior to installation. Our tiles are subject to variations in color, texture, size and finish. Do not install if you have any doubts about visible issues. Misuse by contractor or end-user including but not limited to negligence, physical and/or chemical abuse is not covered by clé's warranty.
- To ensure proper bonding when setting, we recommend lightly wiping the back of each tile if there is excessive dust.
- For rocaille shells, we recommend completely covering the back of the tile with adhesive to ensure the best bond when setting.
- **IMPORTANT:** Fornace Brioni ceramic tiles—like most tiles, cannot be placed where excessive heat is directed onto them (inside fireplaces, pizza ovens and oven venting). If you are wanting to install these behind a stove range/oven vent, we highly recommend that there is at least a 4" metal splash (provided by the range manufacturer) between the tile and the vent to deflect heat from blowing directly onto the tiles.
- If you are installing near something very hot like a pizza oven (backsplash, wall) we recommend at least a 6" space between the tile and oven.

SEALANT

- clé only recommends [Miracle 511 Porous Plus](#) for an invisible, waterproof sealant finish.
 - Always test sealers in a small area to ensure it provides the finish you prefer.
 - We recommend applying sealant or using a grout release prior to grouting if the tile has visible crazing.
 - Please note, if the glazed tile is being grouted with a contrasting grout color vs. a matching one, then you should also seal before grouting.
 - This is because many tiles may have crazing without it being visible to the eye and would only come out with the grouting of the tiles as the invisible crazing absorbs the dye from the contrasting grout.
 - Dry applications do not need to be sealed as the final step of installation.
 - For wet applications (backsplash, shower walls, steam showers) you must seal the grouted areas and areas of visible crazing as the final step of installation. Sealant will not penetrate the glazed tile surface but it is important that all grouted areas and areas of crazing are sealed.
 - If your contractor is having any issues or questions regarding this sealant, please have them reach out to Miracle tech support directly at 1-877-385-8155, as they are the best and fastest line of resolution.
 - PLEASE FOLLOW ALL MIRACLE SEALANT INSTRUCTIONS FOR BEST RESULTS as well as MAINTENANCE UPKEEP RECOMMENDATIONS.*
- * **HINT:** if water or oil does not bead up on the grouted areas then the sealant was not applied properly.

RECOMMENDED GROUT JOINT SIZES AND COLORS

- Glazed Ceramic Tivoli: 1/8"
- Rocaille Shells: 1/8"

GROUT

- clé **ONLY** recommends [Mapei Ultracolor Plus FA](#) grout to reduce the risk of grout haze and staining. Make sure to always follow the manufacturer's instructions. Letting the grout sit for even a short period of time can be problematic.
- Grout color selection is always up to our client and/or their design professional. However, clé is often asked for our opinion on best grout selections for our tiles. And due to the large array of grout colors that are now available, clé would like to offer this general guideline on a foolproof grout color selection for any of your clé tiles.
 - First, have your professional tile contractor complete your tile installation, except for the grout portion.
 - Next, when ready to grout, ask your contractor to bring **ALL** grout color charts from his preferred grout manufacturers, for your review.
 - Lastly, choose a time of day when you are most pleased with the lighting in your space (either natural lighting, installed lighting or a blend of both). During that lighting and time of day, select the grout color that best matches your tile selection.
- Note that the full Mapei Ultracolor Plus FA color catalogue contains 40 colors to choose from. Visit the [Mapei website](#) to view.
- If your contractor is having any issues or questions regarding this grout, please reach out to Mapei tech support directly at 1-800-992-6273 as they are the best and fastest line of contact.
- **IMPORTANT:** During grout application, immediately remove any excess grout off the face of the tile with a clean, damp cloth/sponge. Do not allow grout to cure on the face of the tile as it could cause grout haze and will be hard to remove.

ROCAILLE GROUT

- Grouting is generally not done for dry applications of Rocaille but if you prefer to grout, you will need to finger grout them due to the shape and depth of the tile.
- If you are using the tiles in a wet application (backsplash, shower walls, steam showers), grouting is required. You will need to seal the grout lines as the final step of installation.
- Important: The tiles will need to be back buttered with thinset to help with adhesion when setting. Please note this will increase the drying time before grouting.
- A grout bag can be used to fill the grout joints, but you will still need to pack the grout in with your fingers and finalize the grout line with your finger or a soft, wet cloth.
- Remove excess grout with a clean, slightly damp sponge.
- After grouting, clean any remaining spots of grout from the surface of the tile.
- Follow grout manufacturer's instructions on proper drying time before applying final sealant to grout lines.

GLAZED TIVOLI GROUT

- For glazed Tivoli we recommend using a grout bag to fill the grout joints due to the shape and depth of the tile.
- If you are using the tiles in a wet application (backsplash, shower walls, steam showers), grouting is required. You will need to seal the grout lines as the final step of installation.
- Because of the shape of the tiles it may be easier to use a grout bag to fill the grout joints. We recommend working in small areas to fill the grout joints.
- Float grout over the section that was just filled.
- Remove excess grout with a clean, slightly damp sponge or trowel (do not scratch the tile).
- After grouting, clean any remaining spots of grout from the surface.
- Follow grout manufacturer's instructions on proper drying time before applying final sealant to grout lines.

STAINING

- Grout Staining is only a problem when using a grout other than Ultracolor Plus FA.
- Should your contractor choose to use another brand of grout other than Mapei, be aware that the dyes used to pigment most grouts will stain the tile.
- If your contractor selects brands other than Mapei grout or Miracle sealant, please have them reach out to the respected representatives of those manufactures for advice and support on failures.
- **IMPORTANT:** During grout application, immediately remove any excess grout off the face of the tile with a clean, damp cloth/sponge. If grout is allowed to cure on the face of the tile it could cause grout haze and staining due to the porous nature of the tile.

EXTERIOR
INSTALLATIONS

- **IMPORTANT:** Fornace Brioni glazed ceramic tiles are not freeze thaw rated. Therefore we do not recommend and cannot warrant installing these outdoors in areas that regularly experience freezing temperatures*

* If you plan on installing these outdoors in areas that experience freeze/thaw, we cannot guarantee there won't be installation failures. Installations in freeze/thaw locations require flashing the top of vertical installations to prevent moisture from dripping behind the installation. In addition, the installation must be completely sealed and maintained with a waterproof sealant like Miracle 511 Porous Plus.

With application of Miracle Sealant, these tiles can have resistance to freeze/thaw issues. However, oftentimes there are installation failures because the specific installation guidelines and sealant maintenance is not properly followed. But if completed and maintained correctly (see manufacturer's instructions) then you can proceed WITH CAUTION.

If you can comply with all of the above and understand that without the sealant your install won't hold up - then it's up to you to proceed with installing this tile in a freeze/thaw location. We recommend your contractor reach out to both Mapei tech support for installation support and Miracle Sealant tech support on the waterproofing of the tiles.

MAINTENANCE

- Single coat reapplication of the penetrating sealant is required once a year on all grout lines in shower applications due to the continuous exposure to water.
- Reapplication is needed more frequently if installed in a steam shower.
- For superior water repellency in steam showers, we recommend applying Miracle 511 Impregnator in addition to Miracle 511 Porous Plus.
- For showers and steam showers, opening windows/doors to help some of the moisture dissipate faster after use will help rid extra moisture.
- Check with the Miracle Sealant tech support directly at 1-877-385-8155 for best advice on applying and maintaining sealants.

CLEANING
GUIDELINES

- Glazed ceramic wall tiles require minimal maintenance. Mild, pH neutral soaps should be sufficient for most cleaning - test before general use.
- Clean using soft materials, like a cloth, instead of coarse materials.
- Always avoid harsh chemicals and acidic or alkaline cleaning products.
- Wall installations can be cleaned with warm water and damp microfiber cloth.
- Shower installations should be squeegeed after each use to prevent hard water stains, soap scum and mildew.
- clé recommends the use of Miracle Porcelain & Ceramic Tile Cleaner to remove stubborn stains, grease build up, soap scum, hard water deposits and everyday grime.
- Miracle Tile & Stone Cleaner is effective as an ongoing maintenance cleaner and is gentle for everyday use.
- Grout lines can be cleaned with warm water and a soft bristled cleaning brush.

FORNACE BRIONI GLAZED CERAMIC SPECIFICATIONS

What's in our tile: Fornace Brioni cotto tiles are part of an extraordinary collection of terracotta and ceramic tiles from Gonzaga, a small town in the Lombardy region of Italy, steeped in history and Renaissance culture and renowned for its terracotta. Each cotto tile is created by hand in this family-run company, now in its fourth generation, headed by the Brioni brothers.

The glazed ceramic tiles are made in collaboration with architect and designer Cristina Celestino. The further addition of glazed ceramic tiles round out the offerings with bright modern color choices and sleek lines. The resulting collections delve into themes of classical architecture, with nods to renaissance grottos and italian gardens, and a subtle playfulness enhanced by clean modern forms. Cristina Celestino's first collection for Fornace Brioni, 'Giardino all'Italiana', was inspired by the formal gardens of Italy and was created after observing the geometric forms of trees, topiaries and sculpted hedgerow.

COLOR AND TEXTURE VARIATION

Fornace Brioni glazed ceramic tiles are rated V2, T1

Due to the handmade craftsmanship of many of our tiles and the variety of materials used, there are degrees of variation in our tiles color, shade and texture. These differences are more pronounced in certain types of tiles than others, especially in tiles from separate production lots, or "batches".

The following is a guide for the different degrees of variation that we have assigned our tiles:

COLOR VARIATION

- V1** low variation
- V2** slight variation
- V3** medium variation
- V4** heavy variation
- V5** extreme variation

TEXTURE VARIATION

- T1** smooth
- T2** light texture
- T3** medium texture
- T4** heavy texture

FLOOR RATING

N/A - Glazed Tivoli and Rocaille are for wall applications only.

PRODUCT DESCRIPTION	Non-vitreous glazed ceramic wall tiles.										
PRODUCT COMPONENTS	Clay, glaze, pigments										
DIMENSIONS	<table border="1"> <tr> <td>Rocaille</td> <td>10 cm x 10 cm x 1.6 cm (4" x 4" x 5/8") / 0.10 kg per tile (0.23 lbs)</td> </tr> <tr> <td>Glazed Tivoli</td> <td>11 3/7 cm x 39 2/5 cm x 1 cm (4 1/4" x 15 1/2" x 3/8") / .61 kg per tile (1.3 lbs)</td> </tr> <tr> <td>Glazed Ceramic Pill</td> <td>5.08 cm x 21.6 cm x 0.95 cm (2" x 8 1/2" x 3/8")</td> </tr> <tr> <td>Glazed Ceramic Listello</td> <td>2.22 cm x 12.07 cm x 0.95 cm (7/8" x 4 3/4" x 3/8")</td> </tr> <tr> <td>Glazed Ceramic Rectangle</td> <td>10.16 cm x 21.6 cm x 0.95 cm (4" x 8 1/2" x 3/8")</td> </tr> </table> <p>* Please note all dimensions are nominal and can vary plus or minus 1/4".</p>	Rocaille	10 cm x 10 cm x 1.6 cm (4" x 4" x 5/8") / 0.10 kg per tile (0.23 lbs)	Glazed Tivoli	11 3/7 cm x 39 2/5 cm x 1 cm (4 1/4" x 15 1/2" x 3/8") / .61 kg per tile (1.3 lbs)	Glazed Ceramic Pill	5.08 cm x 21.6 cm x 0.95 cm (2" x 8 1/2" x 3/8")	Glazed Ceramic Listello	2.22 cm x 12.07 cm x 0.95 cm (7/8" x 4 3/4" x 3/8")	Glazed Ceramic Rectangle	10.16 cm x 21.6 cm x 0.95 cm (4" x 8 1/2" x 3/8")
Rocaille	10 cm x 10 cm x 1.6 cm (4" x 4" x 5/8") / 0.10 kg per tile (0.23 lbs)										
Glazed Tivoli	11 3/7 cm x 39 2/5 cm x 1 cm (4 1/4" x 15 1/2" x 3/8") / .61 kg per tile (1.3 lbs)										
Glazed Ceramic Pill	5.08 cm x 21.6 cm x 0.95 cm (2" x 8 1/2" x 3/8")										
Glazed Ceramic Listello	2.22 cm x 12.07 cm x 0.95 cm (7/8" x 4 3/4" x 3/8")										
Glazed Ceramic Rectangle	10.16 cm x 21.6 cm x 0.95 cm (4" x 8 1/2" x 3/8")										
AVERAGE COEFFICIENT OF FRICTION (DCOF ACUTEST)	“Wet Dynamic Coefficient of Friction” (DCOF) / N/A - Not suitable for floor applications.										
FREEZE/THAW RESISTANCE (ASTM C1026)	Fornace Brioni glazed ceramic tiles are not freeze/thaw resistant.										
WATER ABSORPTION TEST (ASTM C373)	Avg. 23.3%; non-vitreous										
ACID RESISTANCE	Fornace Brioni glazed ceramic tiles are not resistant to acids and should be cleaned with pH neutral cleaners.										
LEED CREDITS	<p>The product is an inherently non-emitting source of VOCs (stone, ceramic, metals, powder-coated metals, plated or anodized metal, glass, cement, clay brick, and unfinished or untreated solid wood) and has no integral organic-based surface coatings, binders, or sealants.</p> <p>Fornace Brioni tiles are considered ‘inherently non-emitting sources’ under the Low-emitting Materials Credit of LEEDv4/v4.1. This is currently the only credit for our Fornace Brioni tile that is eligible to be used toward LEED.</p> <p>‘Inherently non-emitting’ means that these tile types have been shown to not contribute emissions to indoor environments and are therefore exempt from demonstrating compliance with CDPH v1.1-2010 or CDPH v1.2-2017.</p> <p>Use of these tiles as Wall or Flooring materials should be entered in the LEED v4.1 low-emitting materials Calculator and identified as ‘inherently non-emitting’ in the Products Tab (Column L).</p> <p>Disclosures for MR Credit Material Ingredient Disclosures under LEEDv4/v4.1, are not available at this time. We are exploring our disclosure options and have not established a timeline for completion.</p>										

Disclosures for MR Credit Environmental Product Declarations under LEEDv4/4.1, are not available at this time. We are exploring our disclosure options and have not established a timeline for completion.

Contribution to MR Credit Material Sourcing under LEEDv4/v4.1, does not apply as there is no recycled content, no bio-based materials, no wood, no reused products included in our tile at this time. Extended producer responsibility programs are highly difficult to manage given the nature of end-of-use tile removal methods. *Tile can last hundreds of years but fashions often change, which is the dominant reason for its removal. We work hard to ensure our stone tiles can withstand the test of time while remaining timeless.*

RECYCLED CONTENT

There is no recycled content in our Fornace Brioni glazed ceramic tiles at this time. See Material Sourcing disclosure above.

PERCENTAGE OF PRE-CONSUMER
AND/OR POST-CONSUMER MATERIALS

There is no pre-consumer or post-consumer material content in our Fornace Brioni glazed ceramic tiles at this time. See Material Sourcing disclosure above.

FIRE RATING

Typically, ceramic tile does not need to have fire rating testing performed. It is our understanding from TCNA that the explanation that ceramic is inorganic, inert, and typically free of materials that could burn or produce smoke is generally enough to satisfy a specifier and that testing is not necessary. Also, the temperatures observed in the testing are typically lower than the temperatures at which ceramic tiles are fired.

Ceramic tile falls under the description, "because ceramic tile is non-flammable and does not produce smoke in a fire, it inherently meets the flame spread and smoke development requirements of Section 803 of the International Building Code (IBC) for interior wall and ceiling materials."

WET AREA APPLICATION

Fornace Brioni glazed ceramic tiles can be installed on backsplashes, shower walls and steam shower walls.

When installing, make sure these specific waterproofing precautions are taken:

- A waterproof membrane is used under the tile and a waterproof, penetrating sealer (Miracle Sealant 511 Porous Plus) is used to seal the grouted area of glazed ceramic tiles. Sealant will not penetrate the glazed tile surface but it is important that all grouted areas are sealed.
- Single coat reapplication of the penetrating sealant is required once a year on all grout lines in shower applications due to the continuous exposure to water.
- Reapplication is needed more frequently if installation is in a steam shower.
- For superior water repellency in steam showers, we recommend applying Miracle 511 Impregnator in addition to Miracle 511 Porous Plus.
- Contact Miracle sealant tech support directly at 1-877-385-8155 for sealant maintenance questions.

* Fornace Brioni is not suitable for pool or fountain use.

