

FORNACE BRIONI GLAZED CERAMIC

USAGE	Y / N
interior floor & wall	N*
exterior floor & wall	N**
residential low traffic	N
residential high traffic	N
commercial low traffic	N
commercial high traffic	N
radiant heating compatible	Y
fireplace surround	Y
shower	Y
steam shower (resealing yearly)	Y
fountain	N
freeze thaw	N
pool	N
heat resistant	N***
backsplash	Y
grout type	ultracolor plus fa
grout joint size	1/8"
UV resistant	Y

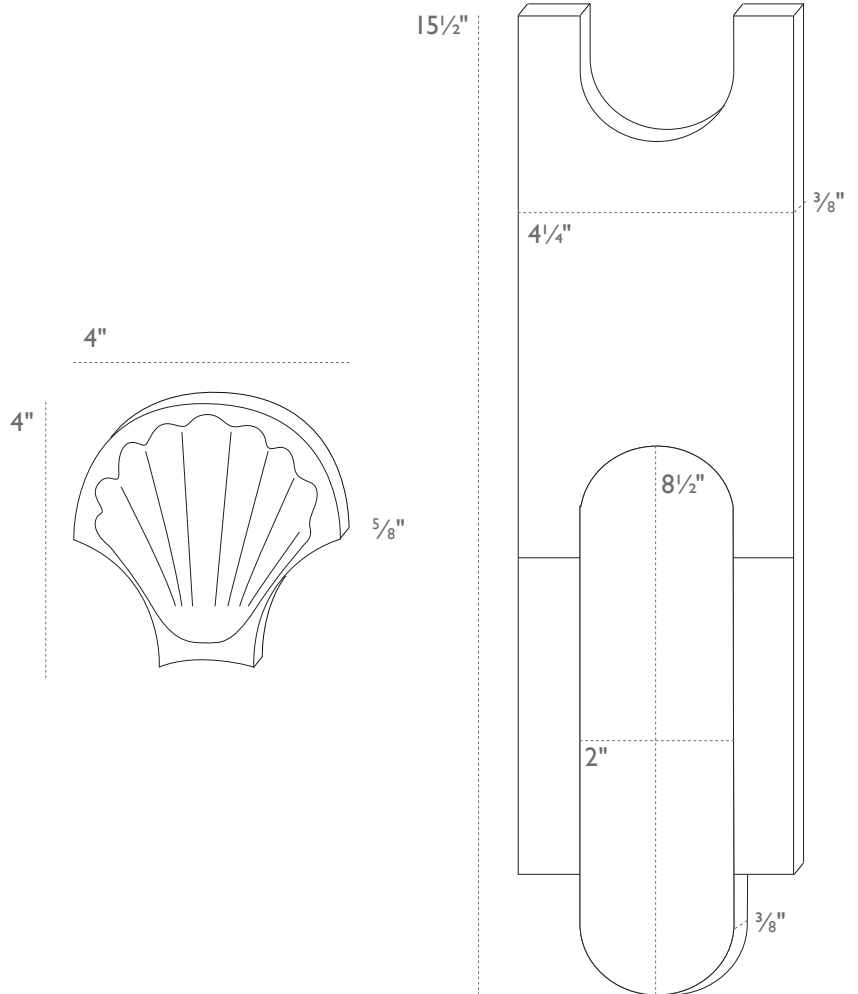

Standard thickness for Glazed Tivoli is 3/8" and 5/8" for Rocaille.

Please note all dimensions are nominal and can vary plus or minus 1/8".

- * Wall use only, not suitable for floors.
- ** Can only be installed on exterior walls and requires vertical weather flashing at the top and application of waterproof, penetrating sealant. Non freeze/thaw locations only.
- *** If installing near something very hot like a pizza oven (on a wall or backsplash) there must be at least a 6" space between the tile and oven.



FORNACE BRIONI GLAZED CERAMIC INSTALLATION

What's in our tile: Fornace Brioni cotto tiles are part of an extraordinary collection of terracotta and ceramic tiles from Gonzaga, a small town in the Lombardy region of Italy, steeped in history and Renaissance culture and renowned for its terracotta. Each cotto tile is created by hand in this family-run company, now in its fourth generation, headed by the Brioni brothers.

The glazed ceramic tiles are made in collaboration with architect and designer Cristina Celestino. The further addition of glazed ceramic tiles round out the offerings with bright modern color choices and sleek lines. The resulting collections delve into themes of classical architecture, with nods to renaissance grottos and Italian gardens, and a subtle playfulness enhanced by clean modern forms. Cristina Celestino's first collection for Fornace Brioni, 'Giardino all'Italiana', was inspired by the formal gardens of Italy and was created after observing the geometric forms of trees, topiaries and sculpted hedgerow.

clé has worked with Fornace Brioni to provide the finest quality tiles available. However, for the best installation, it is important that you hire a highly qualified tile contractor for your project.

YOUR TILE INSTALLATION IS ONLY AS GOOD AS YOUR INSTALLER.

INSPECTING YOUR SHIPMENT

- All Fornace Brioni tiles are made by hand, therefore slight variations in thickness, depth, color, shade and size are to be expected.
 - Due to the slight color and shade variations, it is very important to blend the tiles from all boxes once they arrive and place them in their installation area to ensure you have the layout you want before installing. Do not install without blending tiles from all boxes.
 - Industry standard suggests adding at least 15% overage due to tile cuts, potential breakage, or future repairs.
 - Dust and residue from shipping should be cleaned prior to installing. This can be done with a damp sponge or microfiber cloth.
-

FOR INSTALLATION GUIDELINES

- clé's guides are only to help direct you in the right path for a proper installation. Each project is unique and therefore requires a professional who can provide the exact specifications for your project.
- Please have your installer refer to the current edition of the TCNA Handbook for best installation results and ANSI A137.1 American National Standard Specifications for Ceramic Tile to reference for specifications.
- Tile is merely the surface of your construction. Installation problems will arise from substrate or construction engineering and/or installation issues. Please refer to your project architect, structural engineer and/or installer to have the best results for your tile finish.
- As is standard in the tile industry, installation deems acceptance of materials. Do not install if there are visible issues. If you have any doubts or are unsure of what qualifies as a visible issue for the tile you are installing, please reach out to us prior to installation. Our tiles are subject to variations in color, texture, size and finish. Do not install if you have any doubts about visible issues. Misuse by contractor or end-user including but not limited to negligence, physical and/or chemical abuse is not covered by clé's warranty.

- For rocaïlle shells, we recommend completely covering the back of the tile with adhesive to ensure the best bond when setting.
 - **IMPORTANT:** Fornace Brioni glazed ceramic—like most tiles, **cannot** be placed where excessive heat is directed onto them (inside fireplaces, pizza ovens and oven venting). If you are wanting to install these behind a stove range/oven vent, we highly recommend that there is at least a 4" metal splash (provided by the range manufacturer) between the tile and the vent to deflect heat from blowing directly onto the tiles.
 - If you are installing near something very hot like a pizza oven (backsplash, wall) we recommend at least a 6" space between the tile and oven.
 - **IMPORTANT:** Fornace Brioni glazed ceramic tiles are not freeze thaw rated. Therefore we do not recommend and cannot warrant installing these outdoors in areas that regularly experience freezing temperatures*
- * If you plan on installing these outdoors in areas that experience freeze/thaw, we cannot guarantee there won't be installation failures. Installations in freeze/thaw locations require flashing the top of vertical installations to prevent moisture from dripping behind the installation. In addition, the installation must be completely sealed and maintained with a waterproof sealant like Miracle 511 Porous Plus.

With application of Miracle Sealant, these tiles can have resistance to freeze/thaw issues. However, oftentimes there are installation failures because the specific installation guidelines and sealant maintenance is not properly followed. But if completed and maintained correctly (see manufacturer's instructions) then you can proceed WITH CAUTION.

If you can comply with all of the above and understand that without the sealant your install won't hold up - then it's up to you to proceed with installing this tile in a freeze/thaw location. We recommend your contractor reach out to both Mapei tech support for installation support and Miracle Sealant tech support on the waterproofing of the tiles.

GROUT GUIDELINES

- clé **ONLY** recommends [Mapei Ultracolor Plus FA](#) grout.
- Use of any other grout types can result in installation issues.
- clé recommends a 1/8" grout joint for Rocaille and Glazed Tivoli.
- Grout color selection is always up to our client and/or their design professional. However, clé is often asked for our opinion on best grout selections for our tiles. And due to the large array of grout colors that are now available, clé would like to offer this general guideline on a foolproof grout color selection for any of your clé tiles.
 - First, have your professional tile contractor complete your tile installation, except for the grout portion.
 - Next, when ready to grout, ask your contractor to bring ALL grout color charts from his preferred grout manufacturers, for your review.
 - Lastly, choose a time of day when you are most pleased with the lighting in your space (either natural lighting, installed lighting or a blend of both). During that lighting and time of day, select the grout color that best matches your tile selection.
- Note that the full Mapei Ultracolor Plus FA color catalogue contains 40 colors to choose from. Visit the [Mapei website](#) to view.
- If your contractor selects brands other than Mapei grout or Miracle sealant, please have them reach out to the respected representatives of those manufacturers for advice and support on failures.

- Grouting is generally not done for dry applications of Rocaille but if you prefer to grout, you will need to finger grout them due to the shape and depth of the tile. This entails filling the joints using a grout bag and packing the grout in with your fingers, then finalizing the grout line with your finger or a soft, wet cloth.
- For Glazed Tivoli we recommend using a grout bag to fill the grout joints and then a float to float grout over the section that was just filled.
- We recommend applying sealant or using a grout release prior to grouting if the tile has visible crazing.
- Please note, if the glazed tile is being grouted with a contrasting grout color vs. a matching one, then you should also seal before grouting.
- This is because many tiles may have crazing without it being visible to the eye and would only come out with the grouting of the tiles as the invisible crazing absorbs the dye from the contrasting grout.
- If your contractor is having any issues or questions regarding this grout, please reach out to Mapei tech support directly at 1-800-992-6273 as they are the best and fastest line of contact.

MAINTENANCE & SEALING GUIDELINES

- clé only recommends the use of Miracle 511 Porous Plus for an invisible sealant finish.
- Dry applications do not need to be sealed as the final step of installation.
- For wet applications (backsplash, shower walls, steam showers) you must seal the grouted areas and areas of visible crazing as the final step of installation. Sealant will not penetrate the glazed tile surface but it is important that all grouted areas and areas of crazing are sealed.
- Single coat reapplication of the penetrating sealant is required once a year on all grout lines in shower applications due to the continuous exposure to water.
- For superior water repellency in steam showers, we recommend applying Miracle 511 Impregator in addition to Miracle 511 Porous Plus.
- For showers, opening windows/doors to help some of the moisture dissipate faster after use will help rid extra moisture.
- If your contractor is having any issues or questions regarding this sealant, please have them reach out to Miracle tech support directly at 1-877-385-8155, as they are the best and fastest line of resolution.
- PLEASE FOLLOW ALL MIRACLE SEALANT INSTRUCTIONS FOR BEST RESULTS as well as MAINTENANCE UPKEEP RECOMMENDATIONS.*

* **HINT:** if water or oil does not bead up on the grouted areas then the sealant was not applied properly.

CLEANING GUIDELINES

- Glazed ceramic wall tiles require minimal maintenance. Mild, pH neutral soaps should be sufficient for most cleaning—test before general use.
- Clean using soft materials, like a cloth, instead of coarse materials.
- Always avoid harsh chemicals and acidic or alkaline cleaning products.
- Interior wall installations can be cleaned with warm water and damp microfiber cloth.
- Shower installations should be squeegeed after each use to prevent hard water stains, soap scum and mildew.
- clé recommends the use of Miracle Porcelain & Ceramic Tile Cleaner to remove stubborn stains, grease build up, soap scum, hard water deposits and everyday grime.
- Miracle Tile & Stone Cleaner is effective as an ongoing maintenance cleaner and is gentle for everyday use.
- Grout lines can be cleaned with warm water and a soft bristled cleaning brush.

