



FRIEDRICH

1 8 8 3

VERT-I-PAK®

Single Package Vertical Heat Pumps



18000 & 24000 BTU models use secondary gravity-fed drain (VPDP2).

THE EXPERTS IN ROOM AIR CONDITIONING

CHASSIS SPECIFICATIONS

K-Series models 230/208V, R-Series models 265V

MODEL	VHA09K	VHA09R	VHA12K	VHA12R	VHA18K	VHA18R	VHA24K	VHA24R								
COOLING DATA																
TOTAL COOLING CAP.	9300	9300	11500	11500	18400	18400	22500	22500								
SENSIBLE COOL CAP.	7440	7440	9085	9085	13430	13430	15750	15750								
POWER (W)	845	845	1045	1045	1670	1670	2045	2045								
EER	11.0	11.0	11.0	11.0	11.0	11.0	11.0	11.0								
HEATER SIZE (kW)	2.5/3.4/5.0	2.5/3.4/5.0	2.5/3.4/5.0	2.5/3.4/5.0	2.5/3.4/5.0/7.5	2.5/3.4/5.0/7.5	2.5/3.4/5.0/7.5/10.0	2.5/3.4/5.0/7.5/10.0								
HEAT PUMP DATA																
REVERSE HEATING BTU	8300	8300	10600	10600	16700	16700	19500	19500								
COP @ 47F	3.3	3.3	3.3	3.3	3.3	3.3	3.3	3.3								
HEATING POWER (W)	730	730	940	940	1480	1480	1732	1732								
HEATING CURRENT (A)	3.6	3.1	4.5	3.7	7.0	6.1	9.2	9.2								
ELECTRICAL DATA																
VOLTAGE (1 PHASE, 60 HZ)	208-230	265	208-230	265	208-230	265	208-230	265								
VOLT RANGE	197-253	239-292	197-253	239-292	197-253	239-292	197-253	239-292								
COOLING CURRENT (A)	4.1	3.5	4.9	4.0	7.9	7.0	10.5	10.5								
AMPS L.R	21.0	21.0	23.0	23.0	37.0	37.0	44.0	44.0								
INDOOR MOTOR (HP)	1/4	1/4	1/4	1/4	1/4	1/4	1/5	1/5								
INDOOR MOTOR (A)	1.2	1.2	1.2	1.2	0.42	0.42	1.4	1.4								
OUTDOOR MOTOR (HP)	—	—	—	—	1/4	1/4	1/4	1/4								
OUTDOOR MOTOR (A)	—	—	—	—	1.6	1.6	1.7	1.7								
PHYSICAL																
DIMENSIONS (W X D X H)	23"x23"x32"	23"x23"x32"	23"x23"x32"	23"x23"x32"	23"x23"x47"	23"x23"x47"	23"x23"x52"	23"x23"x52"								
NET WEIGHT (LBS)	142	144	147	149	190	192	225	227								
SHIPPING WEIGHT (LBS)	164	166	169	171	216	218	251	253								
TEST SETTING	LOW	LOW	LOW	LOW	LOW	LOW	LOW	LOW								
R410A CHARGE (OZ)	38.0	38.0	42.1	42.1	57.0	57.0	62	62								
AIRFLOW DATA																
INDOOR CFM	LOW	HIGH	LOW	HIGH	LOW	HIGH	LOW	HIGH	LOW	HIGH	LOW	HIGH	LOW	HIGH	LOW	HIGH
.10" ESP	430	490	430	490	430	490	430	490	630	675	630	675	660	700	660	700
.15" ESP	410	470	410	470	410	470	410	470	595	640	595	640	615	665	615	665
.20" ESP	360	440	360	440	360	440	360	440	550	600	550	600	575	625	575	625
.25" ESP	310	400	310	400	310	400	310	400	505	550	505	550	525	580	525	580
.30" ESP	260	350	260	350	260	350	260	350	455	500	455	500	485	540	485	540
.35" ESP	-	-	-	-	-	-	-	-	400	445	400	445	450	500	450	500
.40" ESP	-	-	-	-	-	-	-	-	345	400	345	400	415	465	415	465
VENT CFM																
UP TO " " CFM	60	60	60	60	60	60	60	60	60	60	60	60	60	60	60	60

NOTES:

Cooling Standards: 95°F DB/75°F WB OUTDOOR, 80°F DB/67°F WB INDOOR
 Heating Standards: 47°F DB/43°F WB OUTDOOR, 70°F DB/60°F WB INDOOR
 Normal Value Wet Coil @ .1" ESP.
 Rated CFM at Low Speed: VHA09 - 430 CFM VHA12 - 430 CFM
 VHA18 - 630 CFM VHA24 - 655 CFM

Due to continuing research in new energy-saving technology, specifications are subject to change without notice.

SMALL CHASSIS ELECTRICAL DATA

ELECTRICAL DATA						
	VHA09K			VHA12K		
HEATER WATTS	2050-2500	2780-3400	4090-5000	2050-2500	2780-3400	4090-5000
VOLTAGE	208-230					
ELECTRIC HEATING BTU	7000-8500	9500-11600	13900-17000	7000-8500	9500-11600	13900-17000
ELEC. HEATING CURRENT (AMPS)	11.1-12.0	14.6-16.0	20.9-22.9	11.1-12.0	14.6-16.0	20.9-22.9
MINIMUM CIRCUIT AMPACITY	15.0	20.0	29.2	15.0	20.0	29.2
BRANCH CIRCUIT FUSE (AMPS)	15	20	30	15	20	30
LRA-COMPRESSOR (AMPS)	21.0	21.0	21.0	23.0	23.0	23.0
BASIC HEATER SIZE	2.5KW	3.4KW	5.0KW	2.5KW	3.4KW	5.0KW
POWER CONNECTION HARD WIRED	HARD WIRED					
RECOMMENDED BRANCH CIRCUIT WIRE SIZES *AWG- AMERICAN WIRE GAUGE	14	12	10	12	12	10

ELECTRICAL DATA						
	VHA09R			VHA12R		
HEATER WATTS	2500	3400	5000	2500	3400	5000
VOLTAGE	265					
ELECTRIC HEATING BTU	8500	11600	17000	8500	11600	17000
ELEC. HEATING CURRENT (AMPS)	10.5	13.9	19.9	10.5	13.9	19.9
MINIMUM CIRCUIT AMPACITY	13.8	18.0	25.7	13.8	18.0	25.7
BRANCH CIRCUIT FUSE (AMPS)	15	20	30	15	20	30
LRA-COMPRESSOR (AMPS)	21.0	21.0	21.0	23.0	23.0	23.0
BASIC HEATER SIZE	2.5KW	3.4KW	5.0KW	2.5KW	3.4KW	5.0KW
POWER CONNECTION HARD WIRED	HARD WIRED					
RECOMMENDED BRANCH CIRCUIT WIRE SIZES *AWG- AMERICAN WIRE GAUGE	14	12	10	12	12	10

LARGE CHASSIS ELECTRICAL DATA

ELECTRICAL DATA									
	VHA18K				VHA24K				
HEATER WATTS	2050-2500	2780-3400	4090-5000	6135-7500	2050-2500	2780-3400	4090-5000	6135-7500	8180-10000
VOLTAGE	208-230								
ELECTRIC HEATING BTU	7000-8500	9500-11600	13900-17000	20900-25600	7000-8500	9500-11600	13900-17000	20900-25600	27900-34100
ELEC. HEATING CURRENT (AMPS)	11.1-12.0	14.6-16.0	20.9-22.9	31.1-34.2	11.3-12.3	14.8-16.2	21.1-23.1	30.9-34.0	40.7-44.9
MINIMUM CIRCUIT AMPACITY	15.0	20.0	29.2	42.8	15.4	20.3	29.0	42.6	56.1
BRANCH CIRCUIT FUSE (AMPS)	15	20	30	45	20	25	30	45	60
LRA-COMPRESSOR (AMPS)	37.0	37.0	37.0	37.0	44.0	44.0	44.0	44.0	44.0
BASIC HEATER SIZE	2.5KW	3.4KW	5.0KW	7.5KW	2.5KW	3.4KW	5.0KW	7.5KW	10.0KW
POWER CONNECTION HARD WIRED	HARD WIRED								
RECOMMENDED BRANCH CIRCUIT WIRE SIZES *AWG- AMERICAN WIRE GAUGE	14	12	10	6	12	10	10	6	4

ELECTRICAL DATA									
	VHA18R				VHA24R				
HEATER WATTS	2500	3400	5000	7500	2500	3400	5000	7500	10000
VOLTAGE	265								
ELECTRIC HEATING BTU	8500	11600	17000	25600	8500	11600	17000	25600	34100
ELEC. HEATING CURRENT (AMPS)	10.5	13.9	19.9	29.9	10.8	14.2	20.3	29.7	39.1
MINIMUM CIRCUIT AMPACITY	13.8	18.0	25.7	37.4	13.6	17.8	25.4	37.2	49.0
BRANCH CIRCUIT FUSE (AMPS)	15	20	30	40	20	20	30	40	50
LRA-COMPRESSOR (AMPS)	37.0	37.0	37.0	37.0	44.0	44.0	44.0	44.0	44.0
BASIC HEATER SIZE	2.5KW	3.4KW	5.0KW	7.5KW	2.5KW	3.4KW	5.0KW	7.5KW	10.0KW
POWER CONNECTION HARD WIRED	HARD WIRED								
RECOMMENDED BRANCH CIRCUIT WIRE SIZES *AWG- AMERICAN WIRE GAUGE	14	12	10	6	12	12	10	6	4

Due to continuing research in new energy-saving technology, specifications are subject to change without notice.

AIRFLOW DATA

Indoor CFM & External Static Pressure

	Model					
	VHA09/VHA12		VHA18		VHA24	
Fan Speed	Low	High	Low	High	Low	High
ESP (")	SCFM					
0.0"	470	520	730	800	755	805
0.05"	460	510	670	735	700	750
0.10"	430	490	630	675	660	700
0.15"	410	470	595	640	615	665
0.20"	360	440	550	600	575	625
0.25"	310	400	505	550	525	580
0.30"	260	350	455	500	485	540
0.35"	--	--	400	445	450	500
0.40"	--	--	345	400	415	465

Indoor air flow may be determined by measuring the external static pressure (ESP) of the duct system using an inclined manometer or magnahelic gauge and consulting the above chart to derive actual air flow. Under no circumstances should the small chassis Vert-I-Pak equipment be operated at an external static pressure in excess of 0.3" W.C. on the VHA09 & VHA12 and 0.4" W.C. on the VHA18 & VHA24. Operation of the Vert-I-Pak under these conditions will result in inadequate air flow, leading to poor performance and/or premature component failure.

Control

For LOW speed only operation, connect the fan output terminal from the thermostat to the GL terminal of the electronic control.

For HIGH speed only operation, connect the fan output terminal from the thermostat to the GH terminal of the electronic control.

For thermostats with two-speed capability, connect the LOW speed output to the GL terminal and the HIGH speed output to the GH terminal.

NOTE: Any non-Friedrich thermostat of low voltage device being powered by the Vert-I-Pak will need to be reviewed and approved for use.

Condenser CFM & External Static Pressure

Model	Design		Maximum
	CFM	ESP (")WC)	ESP (")WC)
VHA09	650	0.03	0.12
VHA12	650	0.03	0.12
VHA18	950	0.03	0.12
VHA24	980	0.03	0.12

and a Friedrich external louver .

If the Friedrich designed plenum and louver combinations are not used, the selections and design must be evaluated by Friedrich to ensure the total pressure drop does not exceed the maximum allowable limits.

UNIT CHASSIS DIMENSIONS - VHA09 & VHA12

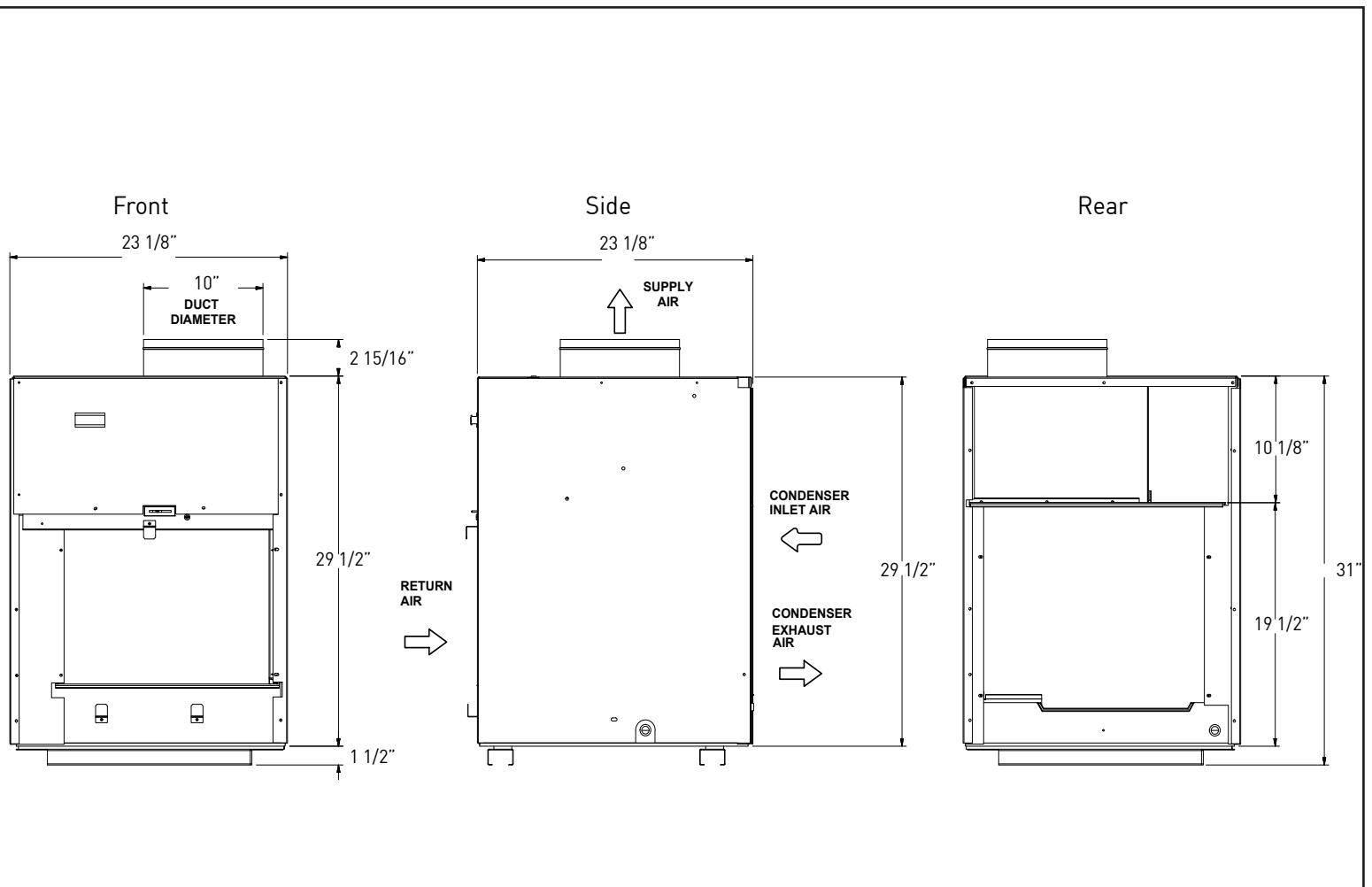

UNIT TOP VIEW DIMENSIONS

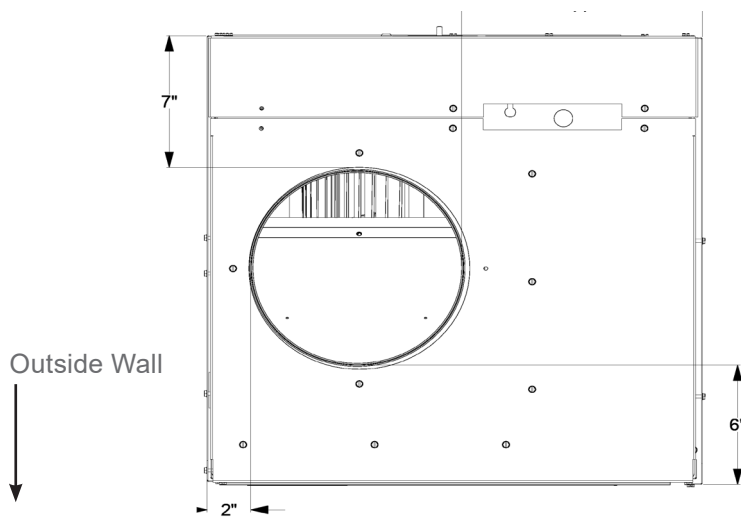

UNIT CHASSIS DIMENSIONS - VHA18

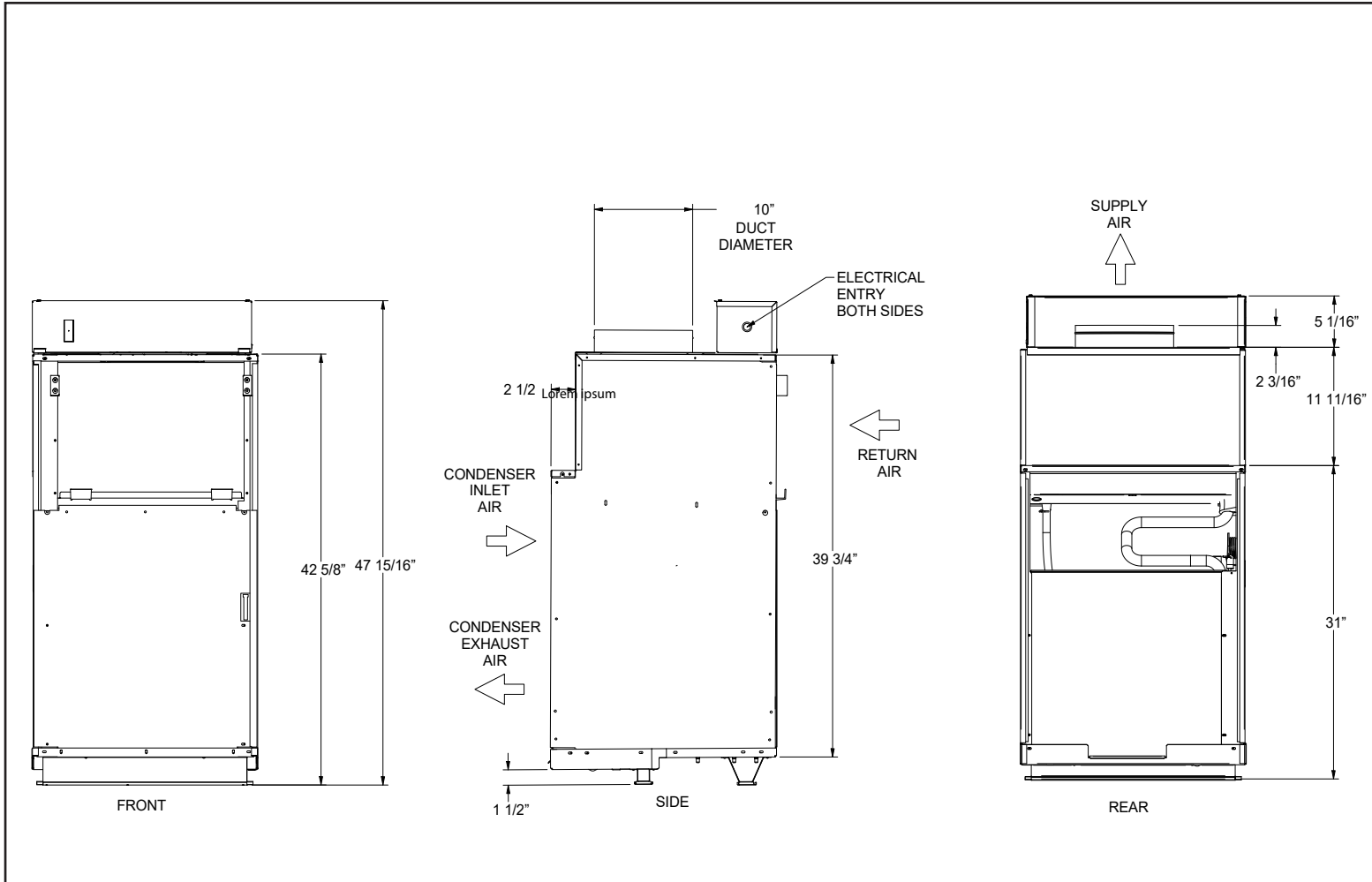

UNIT TOP VIEW DIMENSIONS

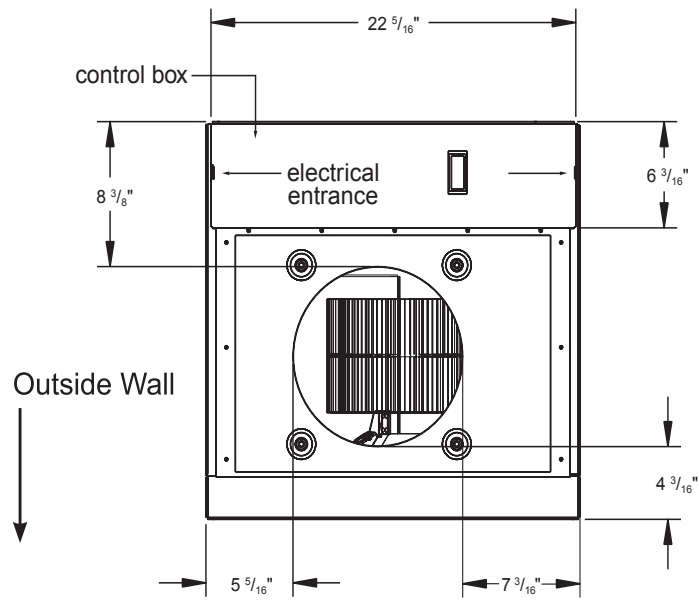

UNIT CHASSIS DIMENSIONS - VHA24

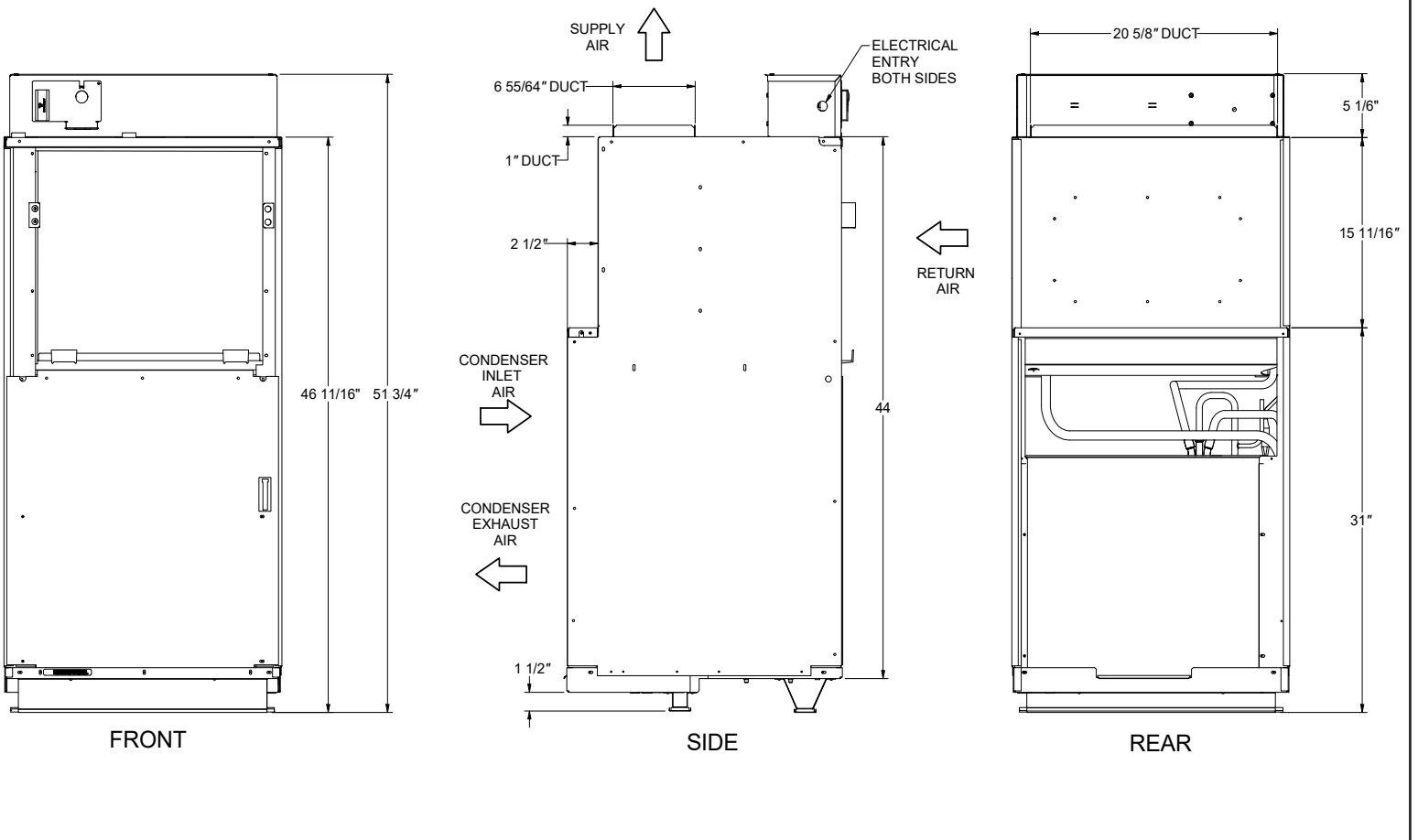

UNIT TOP VIEW DIMENSIONS

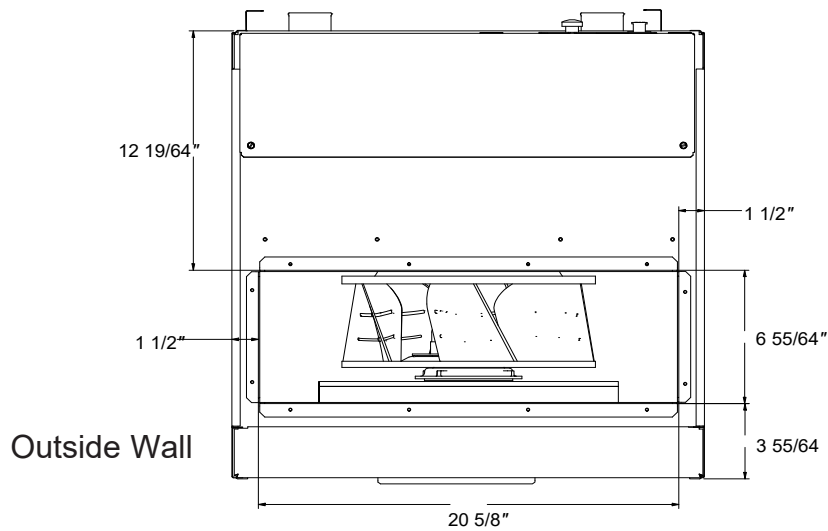

EXTENDED COOLING PERFORMANCE

		OUTDOOR DRY BULB TEMP. (DEGREES F AT 40% R.H.)														
		75			85			95			105			115		
		INDOOR WET BULB TEMP. (DEGREES F AT 80 F D.B.)														
		62	67	72	62	67	72	62	67	72	62	67	72	62	67	72
VHA09K	BTUH	9485	10084	10408	8949	9776	10216	8427	9300	9879	7914	8686	9409	7373	7986	8821
	WATTS	728	738	745	773	789	798	820	845	858	876	904	923	938	965	991
	AMPS	3.6	3.6	3.6	3.7	3.8	3.8	4.0	4.1	4.2	4.3	4.4	4.5	4.6	4.7	4.8
	SHR	0.99	0.73	0.55	1.00	0.77	0.56	1.00	0.80	0.57	1.00	0.83	0.58	1.00	0.87	0.60
VHA12K	BTUH	11608	12169	12488	11218	11916	12319	10763	11500	11975	10304	10962	11476	9785	10339	10847
	WATTS	877	886	893	953	970	979	1023	1045	1059	1092	1114	1132	1158	1178	1199
	AMPS	4.1	4.2	4.2	4.5	4.5	4.6	4.8	4.9	5.0	5.1	5.2	5.3	5.4	5.5	5.6
	SHR	0.99	0.74	0.55	1.00	0.77	0.56	1.00	0.79	0.57	1.00	0.81	0.58	1.00	0.84	0.58
VHA18K	BTUH	18512	19518	20299	17915	19060	19912	17107	18400	19319	16156	17583	18552	15187	16641	17641
	WATTS	1401	1423	1446	1520	1552	1580	1624	1673	1704	1719	1786	1824	1819	1893	1938
	AMPS	6.6	6.7	6.8	7.2	7.3	7.5	7.7	7.9	8.0	8.1	8.4	8.6	8.6	8.9	9.2
	SHR	0.91	0.70	0.52	0.94	0.71	0.53	0.96	0.73	0.54	1.00	0.75	0.54	1.00	0.77	0.55
VHA24K	BTUH	23555	24762	25388	22096	23348	24301	21020	22500	23530	19830	21403	22745	19051	20337	21225
	WATTS	1824	1866	1921	1963	2003	2048	2005	2045	2072	2021	2092	2140	2228	2311	2357
	AMPS	9	9.2	9.4	9.6	9.8	10	10.2	10.5	10.7	10.7	11.1	11.3	11.4	11.8	12.1
	SHR	0.87	0.66	0.49	0.88	0.68	0.5	0.91	0.7	0.51	0.96	0.72	0.5	0.99	0.75	0.5
VHA09R	BTUH	9485	10084	10408	8949	9776	10216	8427	9300	9879	7914	8686	9409	7373	7986	8821
	WATTS	728	738	745	773	789	798	820	845	858	876	904	923	938	965	991
	AMPS	3.1	3.1	3.1	3.2	3.3	3.3	3.5	3.5	3.6	3.7	3.8	3.9	4.0	4.1	4.2
	SHR	0.99	0.73	0.55	1.00	0.77	0.56	1.00	0.80	0.57	1.00	0.83	0.58	1.00	0.87	0.60
VHA12R	BTUH	11608	12169	12488	11218	11916	12319	10763	11500	11975	10304	10962	11476	9785	10339	10847
	WATTS	877	886	893	953	970	979	1023	1045	1059	1092	1114	1132	1158	1178	1199
	AMPS	3.4	3.4	3.4	3.6	3.7	3.7	3.9	4.0	4.1	4.2	4.3	4.3	4.4	4.5	4.6
	SHR	0.99	0.74	0.55	1.00	0.77	0.56	1.00	0.79	0.57	1.00	0.81	0.58	1.00	0.84	0.58
VHA18R	BTUH	18512	19518	20299	17915	19060	19912	17107	18400	19319	16156	17583	18552	15187	16641	17641
	WATTS	1401	1423	1446	1520	1552	1580	1624	1673	1704	1719	1786	1824	1819	1893	1938
	AMPS	5.9	6	6.1	6.4	6.5	6.6	6.8	7.0	7.1	7.2	7.5	7.6	7.6	7.9	8.1
	SHR	0.91	0.70	0.52	0.94	0.71	0.53	0.96	0.73	0.54	1.00	0.75	0.54	1.00	0.77	0.55
VHA24R	BTUH	23555	24762	25388	22096	23348	24301	21020	22500	23530	19830	21403	22745	19051	20337	21225
	WATTS	1824	1866	1921	1963	2003	2048	2005	2045	2072	2021	2092	2140	2228	2311	2357
	AMPS	9	9.2	9.4	9.6	9.8	10	10.2	10.5	10.7	10.7	11.1	11.3	11.4	11.8	12.1
	SHR	0.87	0.66	0.49	0.88	0.68	0.5	0.91	0.7	0.51	0.96	0.72	0.5	0.99	0.75	0.5

RATING
POINT
AHRI
390

INSTALLATION OVERVIEW

VHA09 & VHA12

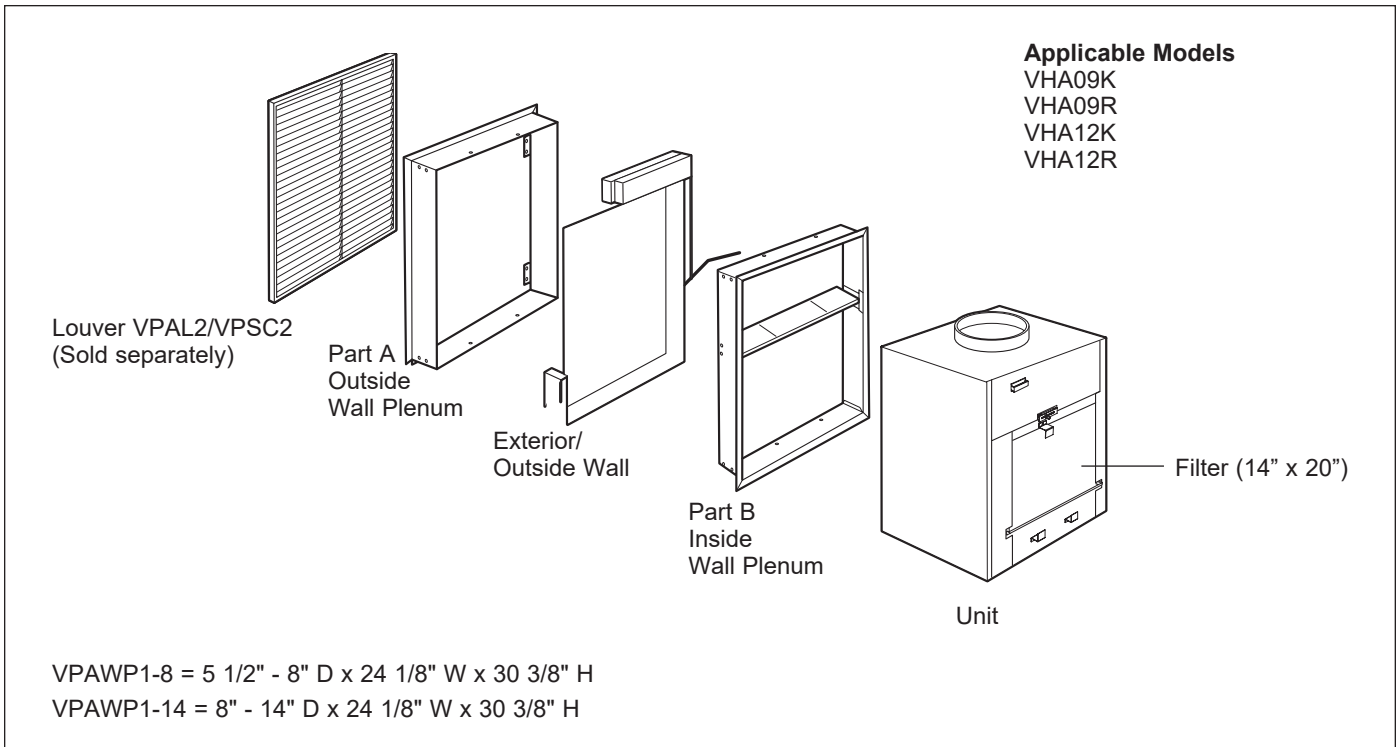

INSTALLATION OVERVIEW

VHA18

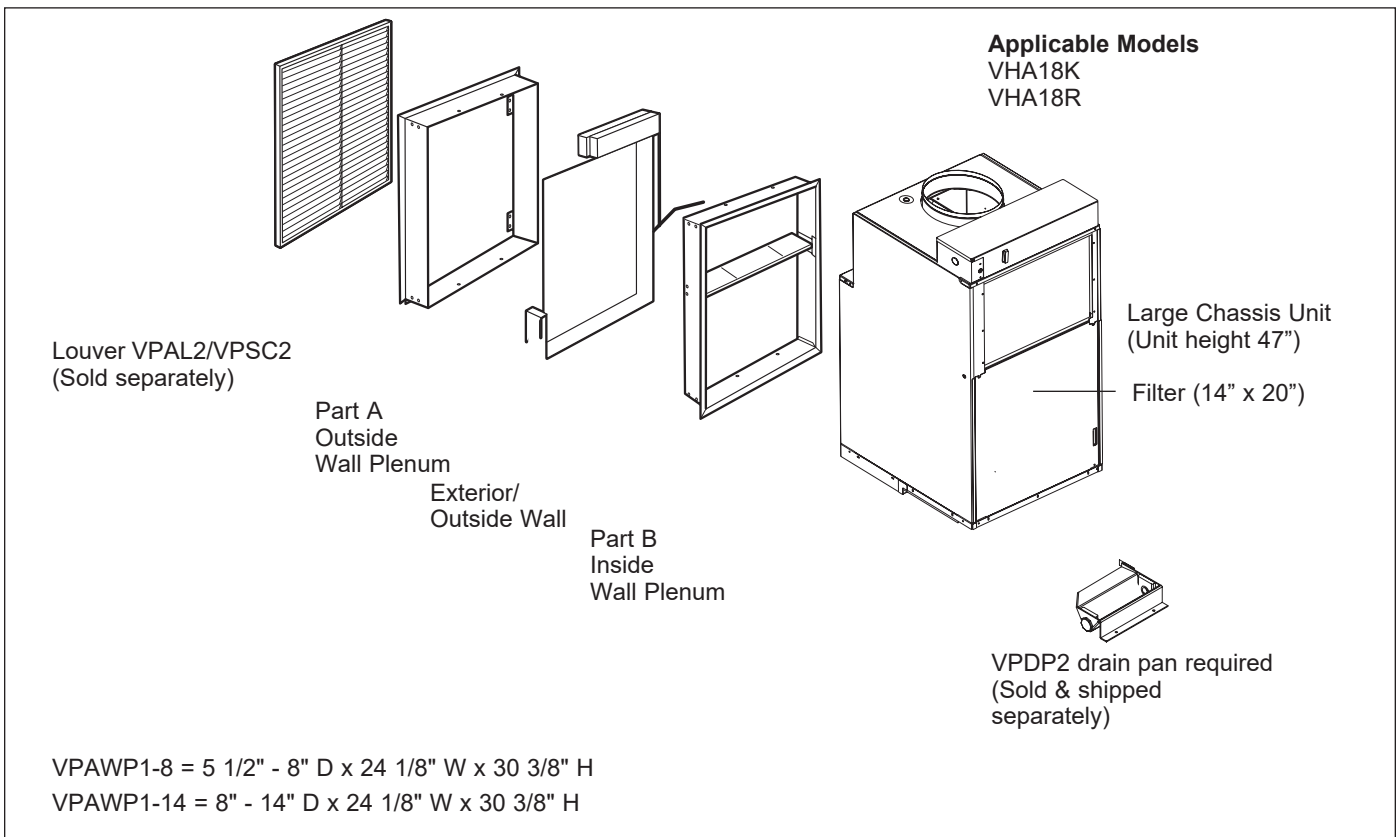

INSTALLATION OVERVIEW

VHA24

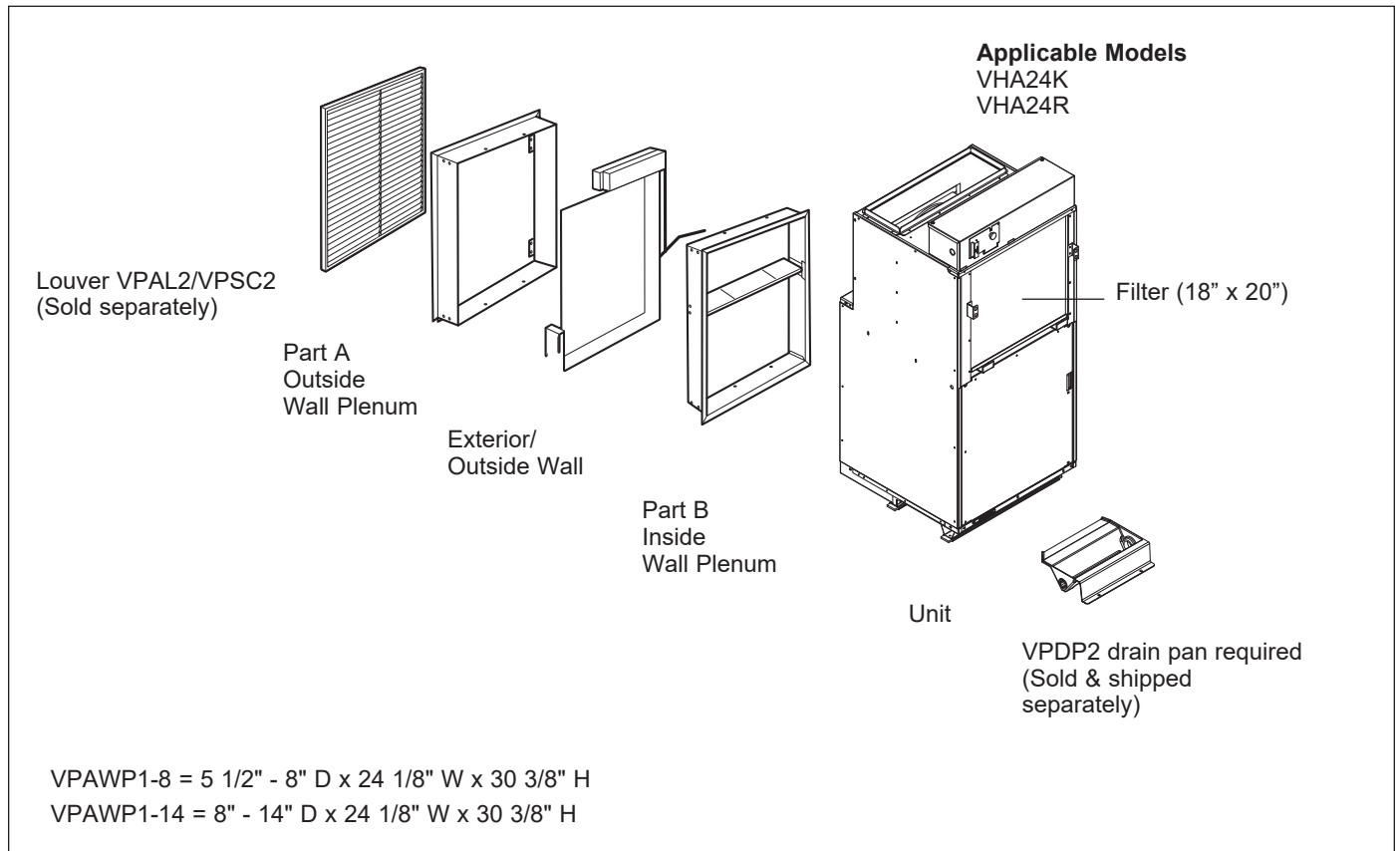

INSTALL HEIGHT

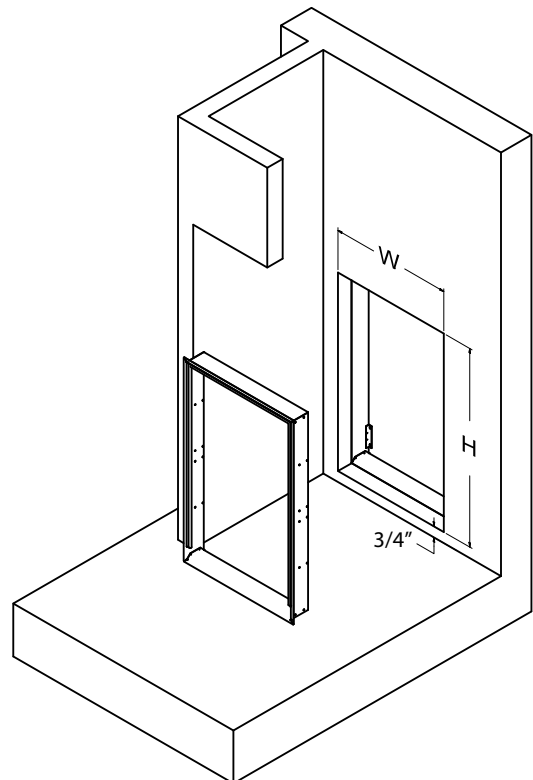

NOTE: The distance between the rough opening and the finished floor/platform must be 3/4".

INSTALLATION OVERVIEW

CLOSET ORIENTATIONS AND DIMENSIONS

Front Installation-Top View

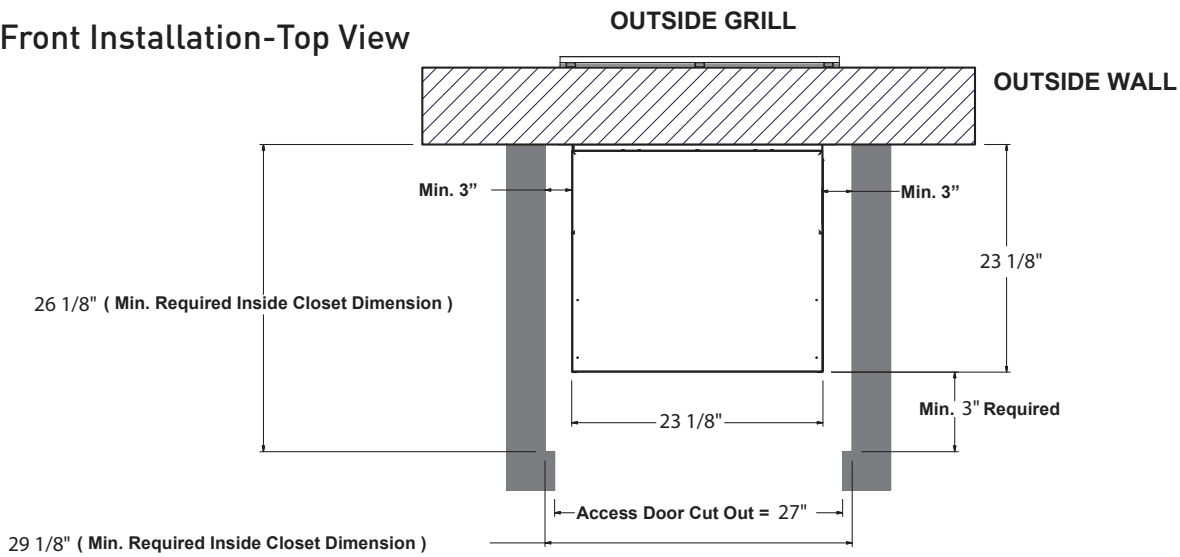

Left Installation-Top View

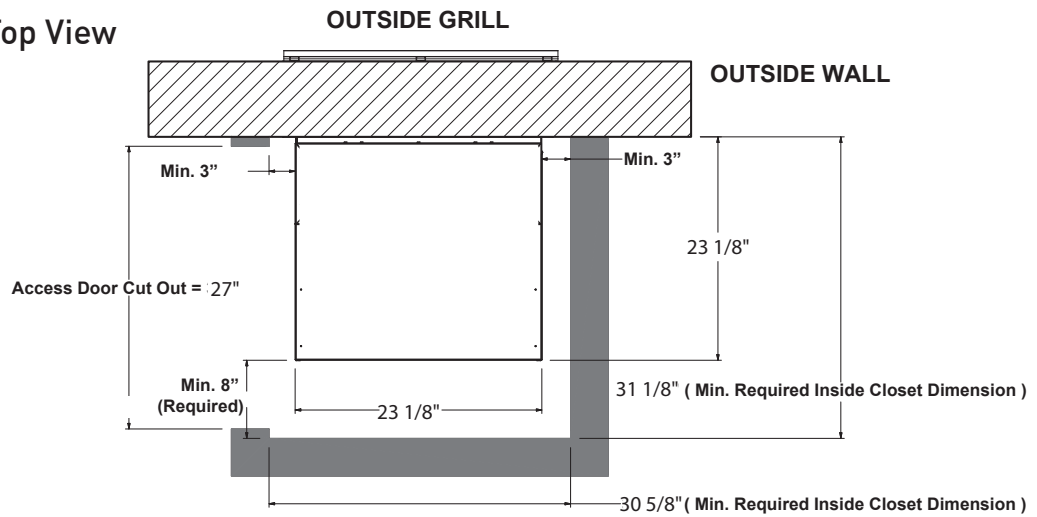

Right Installation-Top View

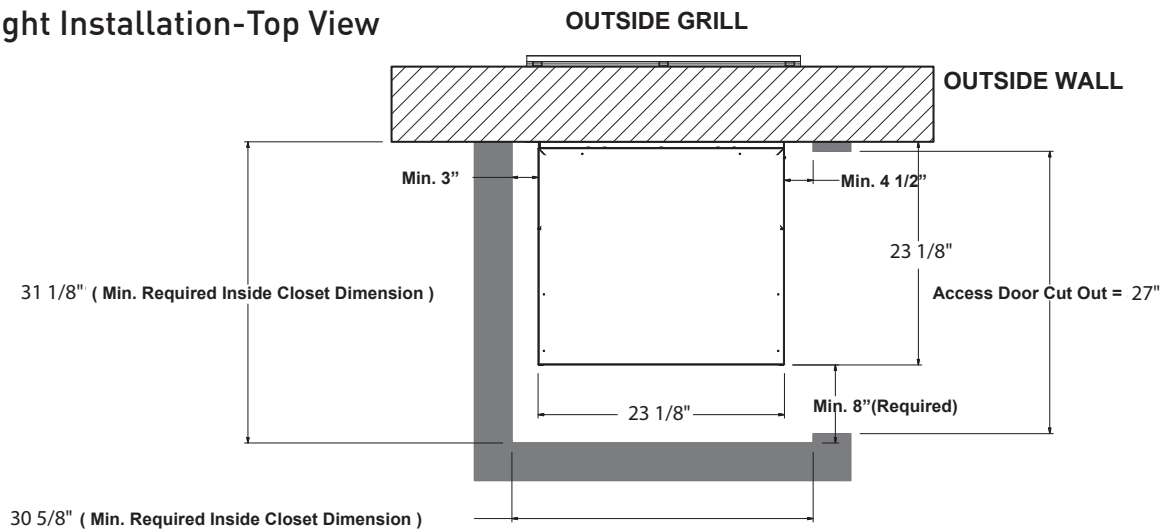

TYPICAL UTILITY CLOSET

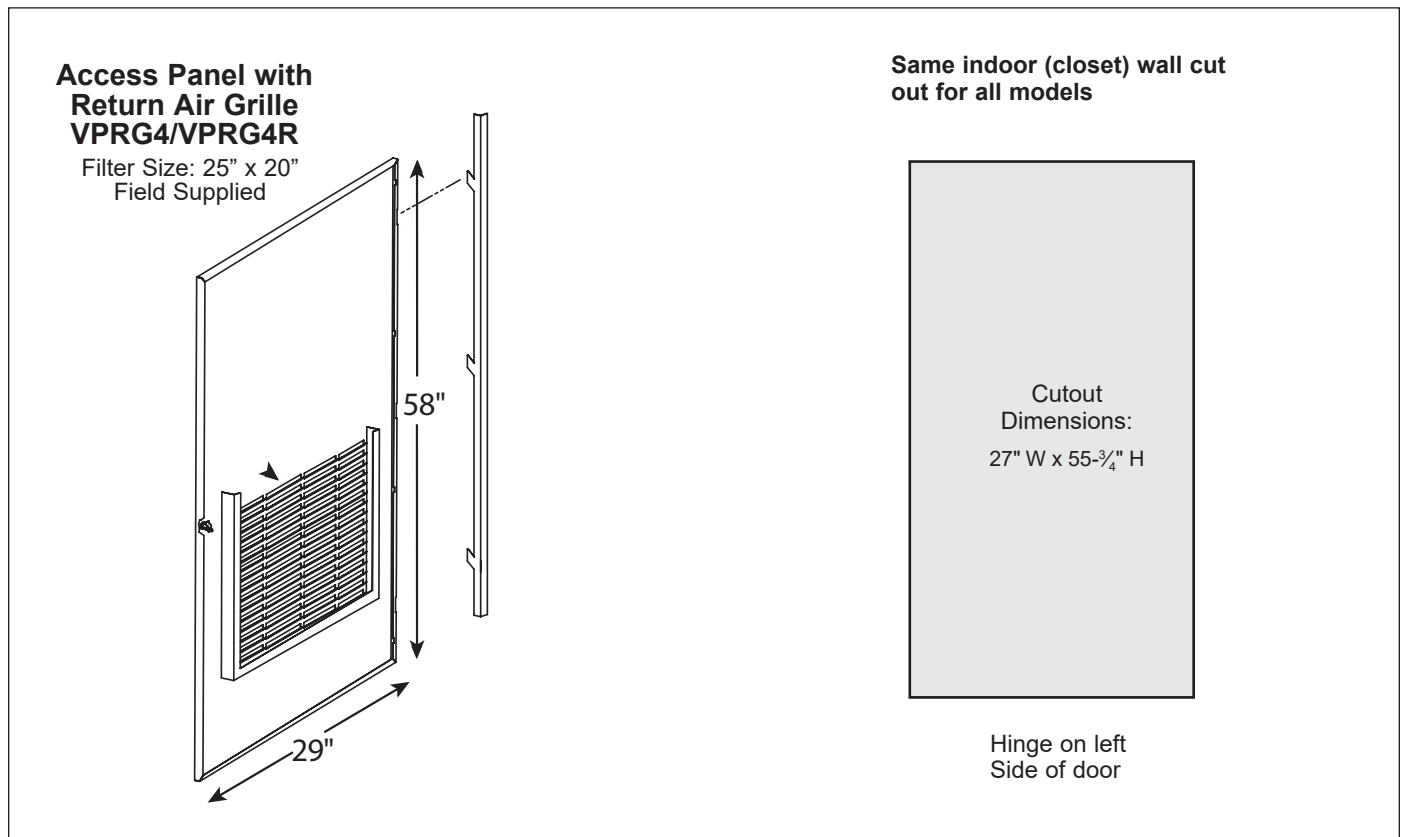
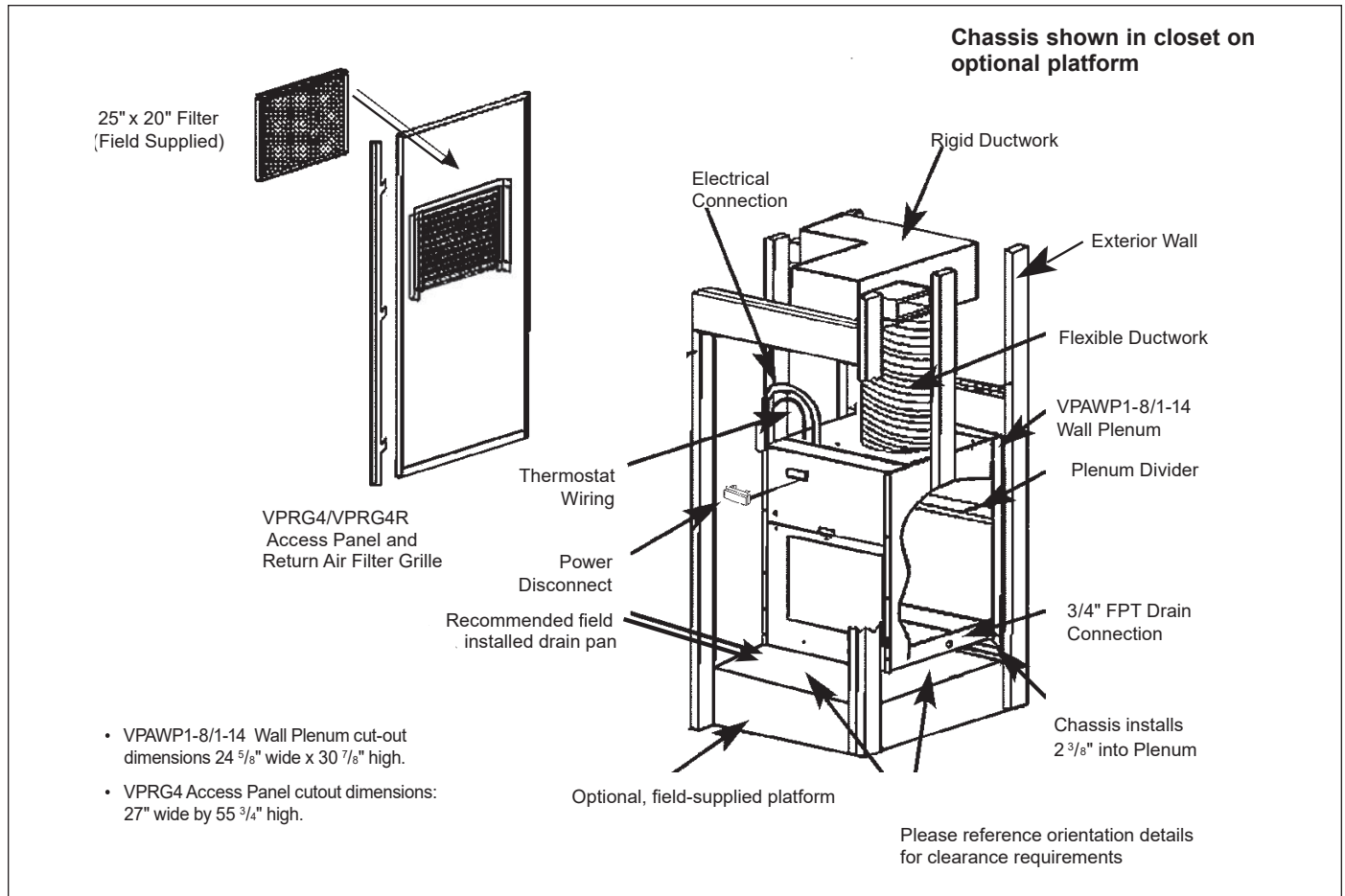

ACCESSORIES DIMENSIONS
VPAL2 / VPSC2 Louver

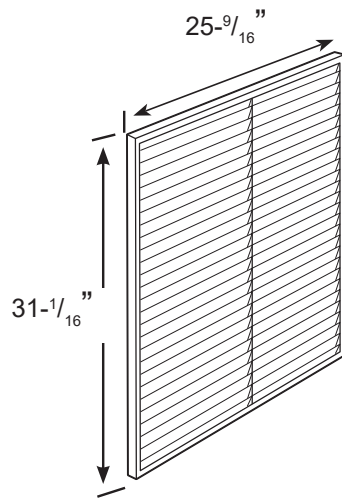

**Architectural Louver
VPAL2/VPSC2**

VPAWP1-8 Wall Plenum

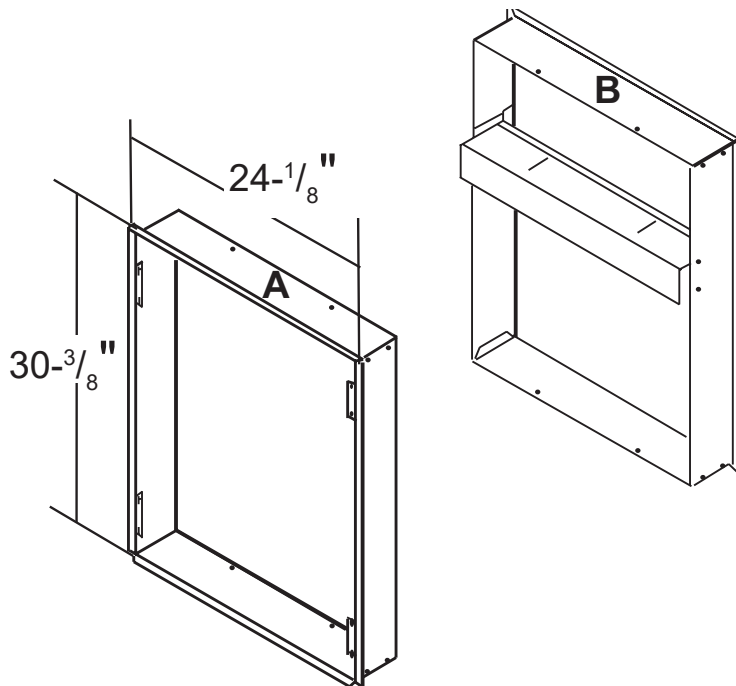

Cutout
Dimensions:
 $24\frac{5}{8}$ " W x $30\frac{7}{8}$ " H

Wall Plenum

VPAWP1-8 - telescopes from $5\frac{1}{2}$ " to 8"
VPAWP1-14 - telescopes from 8" to 14"

Application and Installation

Installation Guidelines

- Chassis is to be installed against an exterior wall. Wall cutout dimensions will be 24 5/8" w x 30 7/8" h.
- Closet should allow for a minimum of three inches on three sides of the unit for return air, drain connections and change outs.
- Minimum recommended access door rough-in measurements 27" wide by 55 3/4" high (for VPRG4/VPRG4R).
- Friedrich recommends the use of a platform between 24" and 36" above the floor, for ease of installation and serviceability.
- Duct outlet designed for external static pressures up to .3" on 9,000 and 12,000, Btu models
- Duct outlet designed for external static pressures up to .4" on 18,000 and 24,000, Btu models
- Wall plenum allows chassis to be inserted 2 3/8" into plenum, thereby minimizing closet dimensions.
- Quick connect drain coupling ships standard to make installation and removal easier.

Application and Accessories (All models)

- The use of a Friedrich wall plenum is required for installation. Plenum opening is 3/4" above the floor (VPAWP1-8 / VPAWP1-14).
- Return air is accommodated with a return air filter attached to the unit or through the use of a return air filter grille. (VPRG4/VPRG4R).
- Exterior louvers are available in anodized aluminum (VPAL2) or in custom painted colors (VPSC2).
- Unit is controlled by a remote wall-mounted thermostat. Friedrich model WRT2 wireless digital thermostat, RT7 wired digital thermostat, RT7P wired programmable thermostat, or EMRT2/EMWRT2 Energy Management Stats are recommended.
- Central desk control ready.

Typical Closet Arrangement

Cutaway of a typical closet shown with Vert-I-Pak® chassis installed in the wall sleeve. The unit has the thermostat, field wiring, internal drain and flex duct attached. VPRG4 return air filter holder and access panel are shown below.

The closet access panel may be installed in the front (as shown below) or to the left or right side of the unit. All three installation options will allow easy access to the unit for removal and replacement.

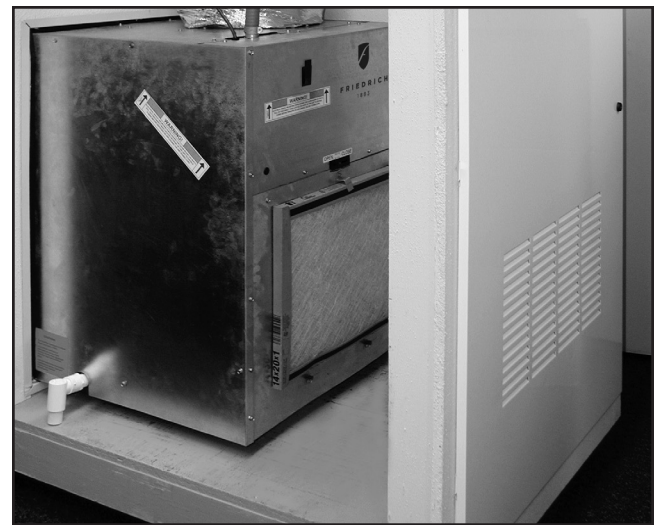

Application and Accessories (18K & 24K Models)

- 18K & 24K utilize a drain pan (VPDP2) that can be installed prior to chassis for simplified installation and removal.

REQUIRED ACCESSORIES

ARCHITECTURAL LOUVER

VPAL2 and VPSC2

Extruded aluminum grille that attaches to the outdoor section of the wall plenum. Takes in fresh air and returns condensed air. VPSC2 can be ordered in custom colors.

DIMENSIONS: 25 9/16" W x 31 1/16" H



VPAL2



VPDP2



VPAWP1-8/14

WALL PLENUM

VPAWP1-8, VPAWP1-14

Two-part sleeve that telescopes in and out. Sits inside the exterior wall penetration.

VPAWP1-8 telescopes from 5 1/2"–8"

VPAWP1-14 telescopes from 8"–14"

DIMENSIONS: 24 1/8" W x 30 3/8" H

CUTOUT DIMENSIONS: 24 5/8" W x 30 7/8" H

DRAIN PAN

VPDP2

Required for all VHA18 and VHA24 models. May be installed prior to chassis for easy installation/removal.

OPTIONAL ACCESSORIES

RETURN AIR GRILLE/ACCESS PANEL

VPRG4 / VPRG4R

Hinged panel allows access to unit and return air filter.

A field-supplied filter (25" x 20") should be mounted on the inside grille. Panel can be mounted with return air openings high or low on the door for optimum sound attenuation.

DIMENSIONS: 29" W x 58" H

CUTOUT DIMENSIONS: 27" W x 55 3/4" H



VPRG4/R

FIRST COMPANY SLEEVE ADAPTER

VPASA1

Single piece, welded adapter allows retrofit into existing First Company SPXR-series single package vertical unit wall sleeve and louver. Easy connection to Friedrich small chassis VERT-I-PAK.



VPASA1

SINGLE STAGE THERMOSTATS

RT7P

Wired, single stage, wall-mounted programmable thermostat has two fan speeds and backlight. Controls Friedrich VERT-I-PAK.

RT7

Wired, single stage, wall-mounted digital thermostat with two fan speeds and backlight for control of Friedrich VERT-I-PAK.

WRT2

Wireless, single stage, wall-mounted digital thermostat with two fan speeds and backlight for control of Friedrich VERT-I-PAK.



RT7



RT7



WRT2

ENERGY MANAGEMENT THERMOSTATS

EMRT2/EMWRT2

Wired/Wireless thermostat with occupancy sensor.

EMOCT

EMRAF

EMROS

Online connection kit. Remote access fee. Remote Occupancy Sensor

EMRTS

EMRDS

EMCWP

EMRWOS

Remote Temperature Sensor Door Switch Wall-Plate Wireless Occ. Sensor



EMRT2, EMWRT2

HVAC Engineering Specifications

A-Series Vertical Packaged Air Conditioners & Heat Pumps

Cooling: 9300 – 22500 Btu

Heating: 8300 – 19500 Btu (Heat Pump)
8500 – 34130 Btu (Electric Heat)

All units shall be factory assembled, piped, wired and fully charged with R-410A. All units shall be certified in accordance with ARI Standard 390 for Single Packaged Vertical Air Conditioners and Heat Pumps. Units shall be ETL listed and carry a ETL label. All units shall be factory run-tested to check operation and be manufactured by Friedrich or equivalent.

The basic unit shall not exceed 23 1/8" wide x 23 1/8" deep. Overall height of the unit from the bottom of the isolators to the top of the duct collar shall not exceed 32 1/4" for models up to 12,000 Btu, 47 1/4" for 18,000 Btu models, and 51 1/4" for 24,000 Btu models. The unit shall be designed so that the unit will insert into a factory supplied wall plenum 2 3/8" to minimize room intrusion. Factory supplied wall plenums shall allow for installation through walls from 4 1/2" – 14" in thickness. Wall plenums will be adjustable to minimize installation clearances. Unit shall draw in ambient air through upper portion of an outside architectural louver measuring 25 9/16" wide x 31 1/16" high and shall exhaust heated air out through the lower portion of the louver. The unit shall be secured to the architectural louver by means of a two part, weather-resistant wall plenum. The unit shall be capable of left, right or straight-in installations into mechanical closet without field modifications.

REFRIGERATION SYSTEM – The refrigeration system shall be hermetically sealed and consist of a rotary compressor that is externally mounted on vibration isolators no smaller than 1 3/4" dia. x 1 1/2" high; condenser and evaporator coils constructed of copper tubes and aluminum plate fins; and capillaries as expansion devices. Unit shall have a fan slinger ring to increase efficiency and condensate disposal. A primary condensate removal system consisting of 3/4" FTP fittings on multiple locations shall exist. A secondary overflow from the primary drain pan shall expel water to the outside of the building through the wall plenum and louver in the event that the primary drain line clogs.

AIR HANDLING SECTION – The condenser fan shall be driven by a single BLDC fan motor for models up to 12,000 Btu. 18,000 and 24,000 Btu models shall utilize a separate motor for both the indoor and outdoor air sections. Airflow shall be directed vertically up through a standard 10" flex duct starter collar and into flexible or rigid ducts to be distributed into the conditioned area on models up to 18,000 Btu. Starter collar shall have both crimped edge to ease flex duct installation and a waistline to prevent duct from loosening.

The chassis shall have a built-in damper capable of providing up to 60 CFM of fresh air into the conditioned area. A fine mesh screen shall filter the incoming fresh air. The damper can be controlled by a slide lever located on the front of the unit.

CONTROLS – The unit shall be factory equipped with terminal strip for connection to a standard 24-volt single-stage heat/cool thermostat. A transformer shall be included and factory wired to work with Friedrich branded or factory approved devices. Low voltage inputs will include: C (common), R (24V power), Y (cooling), G (fan), W (heat) and B (reversing valve on

Friedrich Models: VHA – Heat Pump with electric heat

VHA heat pumps only). The unit shall be hard-wired and have a quick-disconnect to disable power for control box service. An emergency heat override switch must be available to allow operation of the resistance heater in the event of a compressor failure on heat pump models.

GENERAL CONSTRUCTION – The unit shall be constructed of 18-gauge galvanized zinc-coated steel. The unit shall feature 1/2" foil backed insulation for sound and thermal efficiency.

The wall plenum (required factory accessory) shall be shipped separately and constructed of 20-gauge galvanized zinc-coated steel; pretreated with zinc-phosphate and sealed with a chromate rinse, then powder-coated for maximum coverage and protection. The plenum shall be black in color for minimal visibility of unit from exterior of building. The plenum shall be shipped with a protective weatherboard for use prior to final installation of the louver and chassis.

The architectural louver (required factory accessory) shall be shipped separately and fabricated from extruded anodized aluminum with louvers in the horizontal plane.

The unit shall include vibration isolators mounted under the chassis and a nonrigid plenum-to-chassis connection to isolate vibrations to the building.

The unit shall have a plastic fan, fan shroud and drain pan and aluminum outdoor coil endplates for corrosion protection and to help prevent rust on the side of the building below the outdoor louver.

The unit shall be shipped with return air filter brackets and a 14" x 20" or 18" x 20" filter affixed directly on to the unit chassis. Optional return air grilles and access panels shall be available as factory accessories for installation in the wall or door of the mechanical closet.

CORROSION PROTECTION - The unit shall feature corrosion-resistant materials and finish to help prevent deterioration.

The outdoor coil shall have Diamonblue advanced corrosion protection consisting of hydrophilic-coated fins to prolong the life of the coil in all applications including seacoast protection.

ACCESSORY ACCESS PANEL - An optional factory-supplied access panel shall be available to provide access to the unit and adequate return air. The panel shall feature a filter holder to accept a field supplied 25" x 20" x 1" filter. Kit shall contain a hinge bracket for mounting the door with the return air openings high or low on the door for optimal sound attenuation.

WARRANTY – The warranty is one year on all parts and labor and 5 years on the sealed system, parts and labor, including compressor, indoor and outdoor coils and refrigerant tubing.

PURCHASER	P.O. #	DATE
PROJECT	LOCATION	
ENGINEER	ARCHITECT	
SUBMITTED BY	FOR APPROVAL	FOR REFERENCE

ITEM	PLAN DESIGNATION	QUANTITY	COOLING Btu	VOLTAGE	FRIEDRICH MODEL

A-SERIES ACCESSORIES (Wall Plenum and Outdoor Louver are required)

VPAWP1-8 Adjustable Wall Plenum (5 ½"- 8")	Qty	
VPAWP1-14 Adjustable Wall Plenum (8"-14")	Qty	
VPAL2 Architectural Louver	Qty	
VPSC2 Architectural Louver (color matched)	Qty	
VPASA1 Sleeve adapter for exact fit in existing First Company SPXR-series with small chassis VPAK	Qty	
VPRG4 Return Air Grille/Access Panel	Qty	
VPRG4R Access Panel (Right In-swing)	Qty	
VDPDP2 Drain Pan for VHA18 & VHA24	Qty	

RT7 Wired Digital Wall Thermostat	Qty	
RT7P Wired Programmable Wall Thermostat	Qty	
WRT2 Wireless Digital Wall Thermostat	Qty	
EMRT2 Wired Thermostat with Occupancy Sensor	Qty	
EMWRT2 Wireless Thermostat with Occupancy Sensor	Qty	
EMOCT Online Connection Kit	Qty	
EMRAF Remote Access Fee	Qty	
	Qty	
	Qty	

MODEL IDENTIFICATION GUIDE

MODEL NUMBER	V	H	A	09	K	34	RT	P
<p>Series VHA=Vertical Heat Pump</p> <p>Nominal Capacity <u>A Series (Btu)</u> 09 = 9,000 18 = 18,000 12 = 12,000 24 = 24,000</p> <p>Voltage K = 208/230V-1Ph-60Hz R = 265V-1Ph-60Hz</p>								<p style="text-align: center;">Marketing Model</p> <p style="text-align: center;">Options RT = Standard Remote Operation</p> <p>Electric Heater Size <u>A Series</u> 25 = 2.5 KW 34 = 3.4 KW 50 = 5.0 KW 75 = 7.5 KW* 10 = 10.0KW**</p> <p style="font-size: small;">* ONLY AVAILABLE ON THE 18 & 24 K/R MODELS **ONLY AVAILABLE ON THE 24 K/R MODELS</p>



Friedrich Air Conditioning Company
10001 Reunion Place, Suite 500
San Antonio, Tx 78216
800.541.6645
www.friedrich.com

VERT-I-PAK® A SERIES SINGLE PACKAGE VERTICAL AIR CONDITIONERS LIMITED WARRANTY

SAVE THIS CERTIFICATE. It gives you specific rights. You may also have other rights which may vary from state to state and province to province.

In the event that your unit needs servicing, contact your nearest authorized service center. If you do not know the nearest service center, ask the company that installed your unit or contact us - see address and telephone number above. To obtain service and/or warranty parts replacement, you must notify an authorized FRIEDRICH Air Conditioning Co. service center, distributor, dealer, or contractor of any defect within the applicable warranty period.

When requesting service: please have the **model** and **serial number** from your unit readily available.

Unless specified otherwise herein, the following applies:
FRIEDRICH VERT-I-PAK A SERIES HEAT PUMPS & AIR CONDITIONERS

LIMITED WARRANTY - FIRST YEAR (Twelve (12) months from the date of installation). Any part found to be defective in the material or workmanship will be repaired or replaced free of charge by our authorized service center during the normal working hours; and

LIMITED WARRANTY - SECOND THROUGH FIFTH YEAR (Sixty (60) months from the date of installation). ON THE SEALED REFRIGERATION SYSTEM. Any part of the sealed refrigeration system that is defective in material or workmanship will be repaired or replaced free of charge (excluding freight charges) by our authorized service center during normal working hours. The sealed refrigeration system consists of the compressor, metering device, evaporator, condenser, reversing valve, check valve, and the interconnecting tubing.

These warranties apply only while the unit remains at the original site and only to units installed inside the continental United States, Alaska, Hawaii, Puerto Rico, Mexico and Canada. The warranty applies only if the unit is installed and operated in accordance with the printed instructions and in compliance with applicable local installation and building codes and good trade practices. For international warranty information, contact the Friedrich Air Conditioning Company - International Division.

Any defective part to be replaced must be made available to **FRIEDRICH** in exchange for the replacement part. Reasonable proof must be presented to establish the date of install, otherwise the beginning date of this certificate will be considered to be our shipment date plus sixty days. Replacement parts can be new or re-manufactured. Replacement parts and labor are only warranted for any unused portion of the unit's warranty.

We will not be responsible for and the user will pay for:

1. Service calls to:
 - A) Instruct on unit operation. B) Replace house fuses or correct house wiring. C) Clean or replace air filters. D) Remove the unit from its installed location when not accessible for service required. E) Correct improper installations.
2. Parts or labor provided by anyone other than an authorized service center.
3. Damage caused by:
 - A) Accident, abuse, negligence, misuse, riot, fire flood or acts of God. B) Operating the unit where there is a corrosive atmosphere containing chlorine, fluorine, or any damaging chemicals (other than in a normal residential environment). C) Unauthorized alteration or repair of the unit, which in turn affects its stability or performance. D) Failing to provide proper maintenance and service. E) Using and incorrect power source. F) Faulty installation or application of the unit. G) Operation of the unit during construction.

We shall not be liable for any incidental, consequential, or special damages or expenses in connection with any use or failure of this unit. We have not made and do not make any representation or warranty of fitness for a particular use or purpose and there is no implied condition of fitness for a particular use or purpose. We make no expressed warranties except as stated in this certification. No one is authorized to change this certificate or to create for us any other obligation or liability in connection with this unit. Any implied warranties shall last for one year after the original purchase date. Some states and provinces do not allow limitations on how long an implied warranty or condition lasts, so the above limitation or exclusions may not apply to you. The provisions of this warranty are in addition to and not a modification of or subtraction from the statutory warranties and other rights and remedies provided by law.

Performance of Friedrich's Warranty obligation is limited to one of the following methods:

1. Repair of the unit
2. A refund to the customer for the prorated value of the unit based upon the remaining warranty period of the unit.
3. Providing a replacement unit of equal value

The method of fulfillment of the warranty obligation is at the sole discretion of Friedrich Air Conditioning.

In case of any questions regarding the provisions of this warranty, the English version will govern.



Friedrich Air Conditioning Co. | 10001 Reunion Place, Suite 500 | San Antonio, TX 78216 | 877.599.5665 | www.friedrich.com